

Barbie™

Free Spirit Trike

Instructions

Model Number: 72639



Please keep these instructions for future reference.

Adult assembly is required.

Tools needed for assembly: Hammer, Phillips Screwdriver, Scrap Block of Wood (all not included).

If you have any questions about this product, or are missing a part, please call us toll-free at 1-800-432-KIDS, rather than return this product to the store.

Age: 2 - 5 years.

Weight Limit: 55 lbs.

IMPORTANT!

- Please save all packaging material until assembly is complete to ensure that no parts are discarded.
- If you are missing a part, please call us toll-free at **1-800-432-KIDS**, rather than return this product to the store.
- Please wipe each part with a clean, dry cloth before assembly.

**WARNING**

- Adult supervision is required.
- Never use near steps, sloped driveways, hills, roadways, alleys, swimming pools or other bodies of water.
- Always wear shoes or sneakers.
- Never allow more than one rider.

Parts

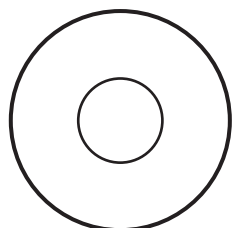
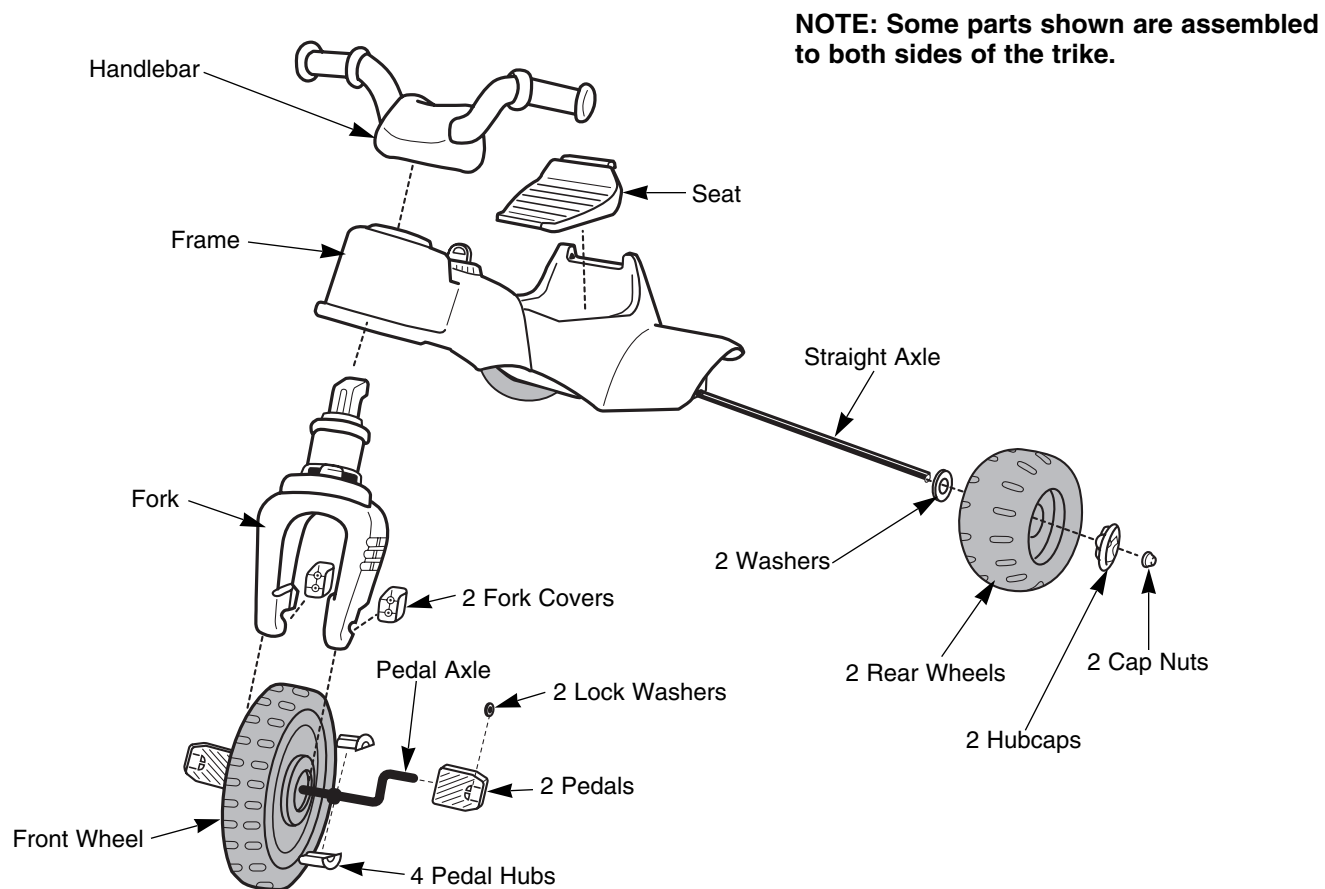

Washer – 2



#8 x 3" Screw – 1



#8 x 3/4" Screw – 4



Cap Nut – 2

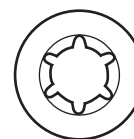

Lock Washer – 2

ALL SHOWN ACTUAL SIZE

Assembly

CAUTION

This product contains small parts in its unassembled state. Adult assembly is required.

1

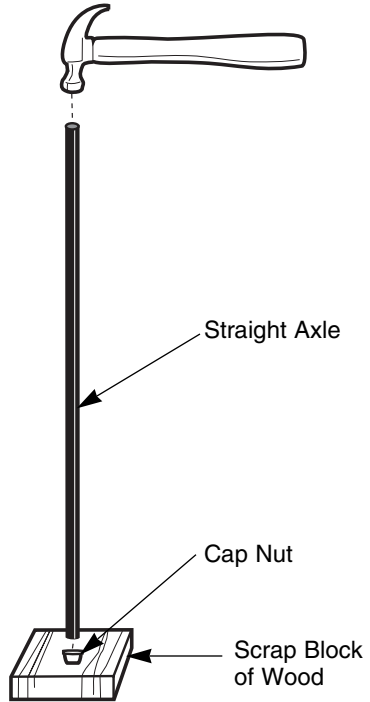

- Place a cap nut on a scrap block of wood.
- Place one end of the straight axle into the cap nut.
- Tap the end of the straight axle with a hammer. **Make sure the cap nut is securely attached to the straight axle.**

2

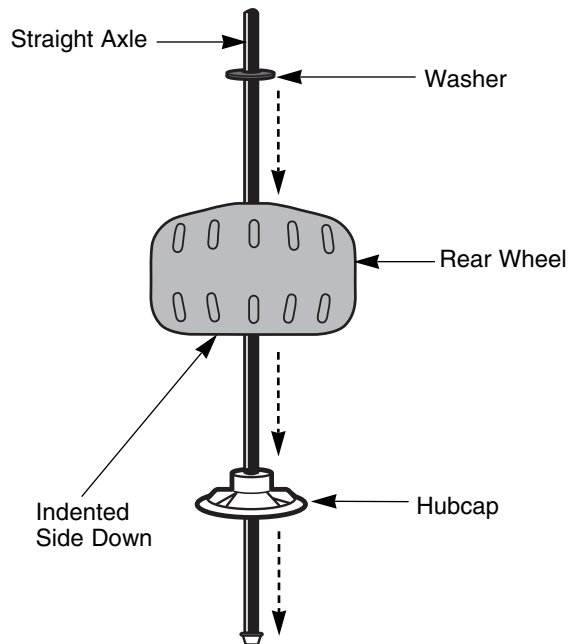

- Slide a hubcap (peg side up) onto the straight axle.
- Slide a rear wheel (indented side down) onto the straight axle.
- Slide a washer onto the straight axle.

3

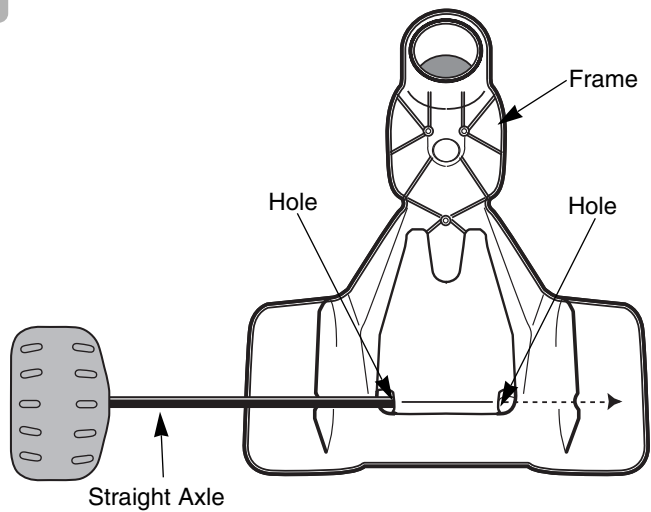

Bottom View

- Turn the frame upside down.
- Insert the straight axle through the holes in the rear of the frame.

Assembly

4

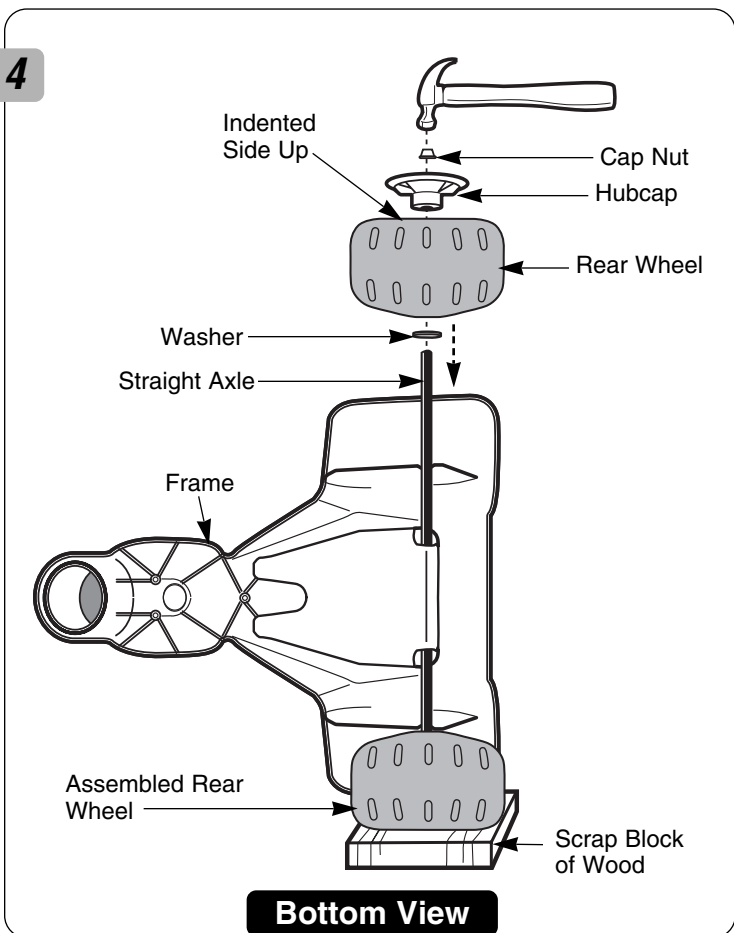

- Turn the frame on its side with the exposed end of the straight axle up.
- Place the assembled rear wheel on the scrap block of wood.
- Slide a washer onto the straight axle.
- Slide a rear wheel (indented side up) onto the end of the straight axle.
- Slide a hubcap (peg side down) onto the straight axle.
- Fit a cap nut on the end of the straight axle.
- Tap the cap nut with a hammer. **Gently pull the rear wheel up to be sure the cap nut is securely attached to the straight axle.**
- Set the frame assembly aside.

5

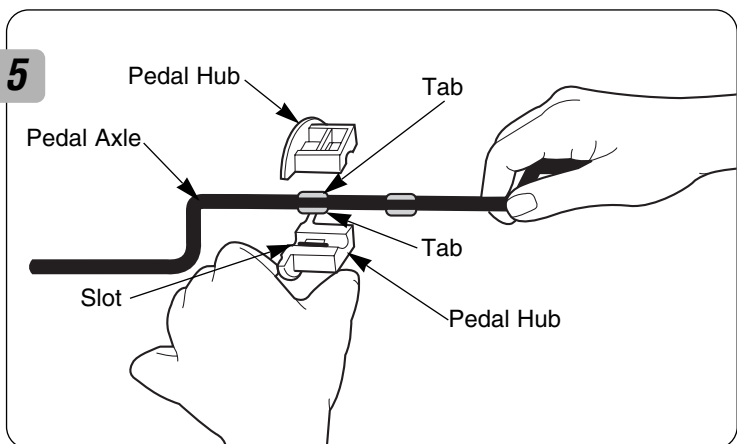

- Fit two pedal hubs onto the pedal axle tabs. Make sure the tabs fit into the slot in each pedal hub.

6

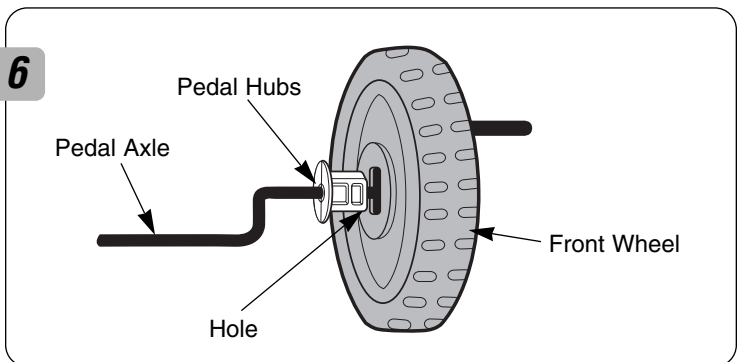

- While holding the pedal hubs on the pedal axle, insert the pedal axle through the hole in the center of the front wheel.

7

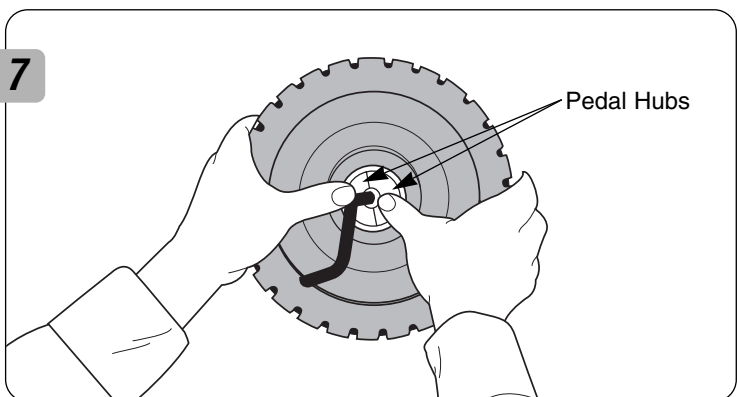

- Push the pedal hubs into the center of the front wheel until they are flush with the surface of the front wheel.

Assembly

8

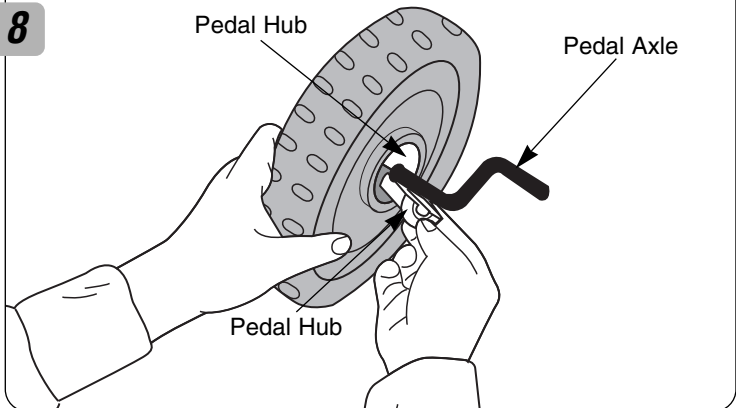

- Turn the front wheel assembly over.
- Insert a pedal hub onto the top of the pedal axle and into the hole in the center of the front wheel.
- Insert the remaining pedal hub below the pedal axle and into the hole in the center of the front wheel.

9

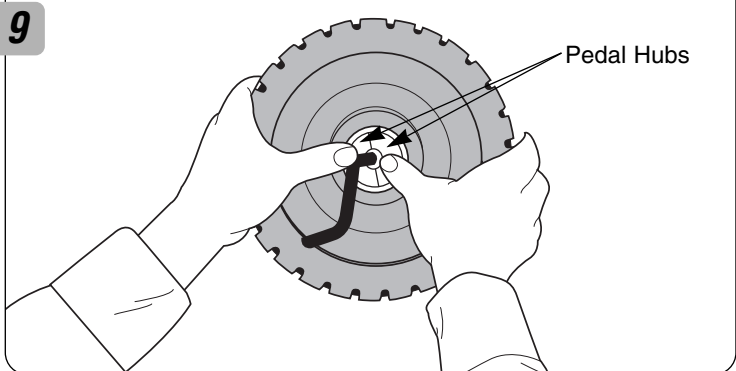

- Push the pedal hubs into the center of the front wheel until they are flush with the surface of the front wheel.

10

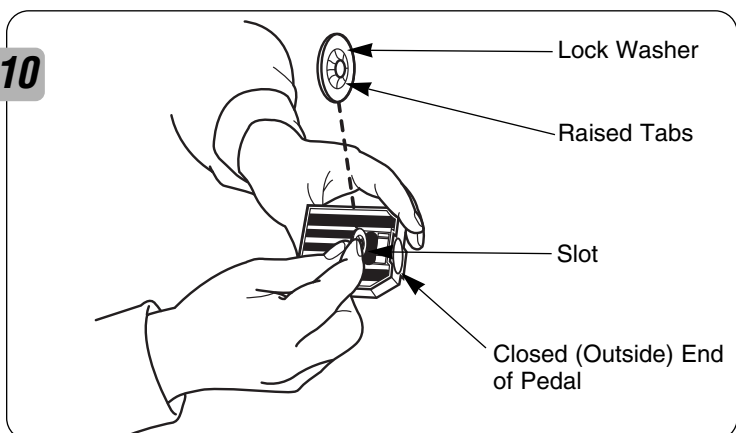

- Insert a lock washer into the slot in the pedal. **Make sure the raised tabs on the lock washer are facing the "closed" or outside end of the pedal.**
- Insert the other lock washer into the other pedal.

11

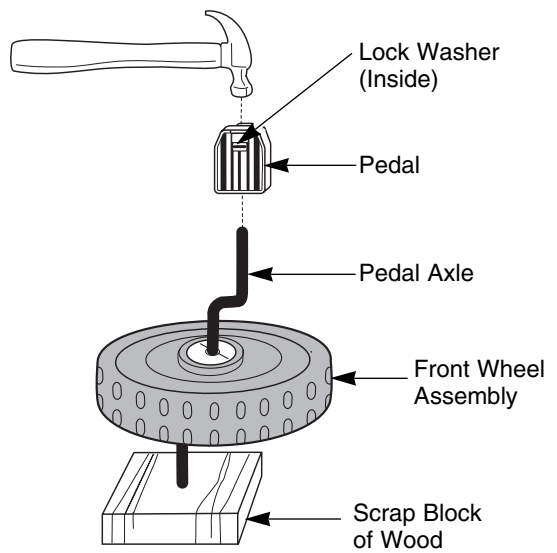

- Place a scrap block of wood under the front wheel assembly.
- Fit a pedal on the pedal axle.
- With the lock washer centered over the pedal axle end, tap the pedal with a hammer until it is secure.
- Repeat this procedure to attach the other pedal to the other end of the pedal axle.

12

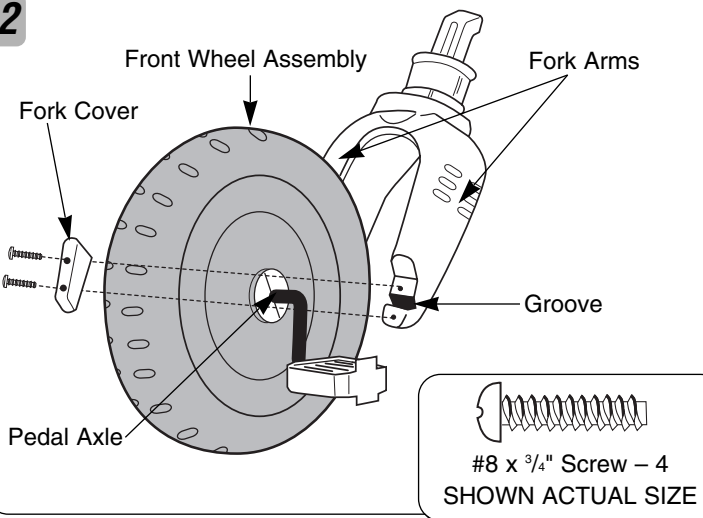

- Place the front wheel assembly between the fork arms. Make sure the pedal axle fits into the groove at the bottom of each fork arm.
- Place a fork cover over the pedal axle on one fork arm.
- Insert two #8 x 3/4" screws through the fork cover and into the fork arm. Tighten the screws with a Phillips screwdriver. Do not over-tighten.
- Repeat this procedure to attach the other fork cover to the other fork arm.

Assembly

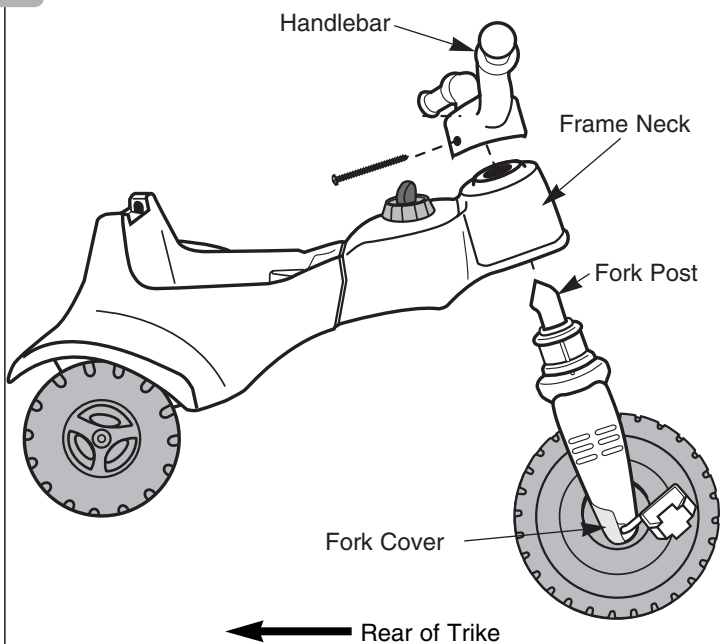
13

#8 x 3" Screw – 1
SHOWN ACTUAL SIZE

- Turn the frame upright.
- Insert the fork post up through the hole in the neck of the frame. **Make sure the fork is positioned so that the fork covers face the rear wheels.**
- Place the handlebar over the fork post and push it down onto the frame. Make sure the handlebar is positioned so that the screw hole faces the rear wheels and aligns with the screw hole in the fork post.

Hint: You may need to rotate the handlebar to align the holes.

- Insert the #8 x 3" screw through the hole in the handlebar and into the fork post. Tighten the screw with a Phillips screwdriver. Do not over-tighten.

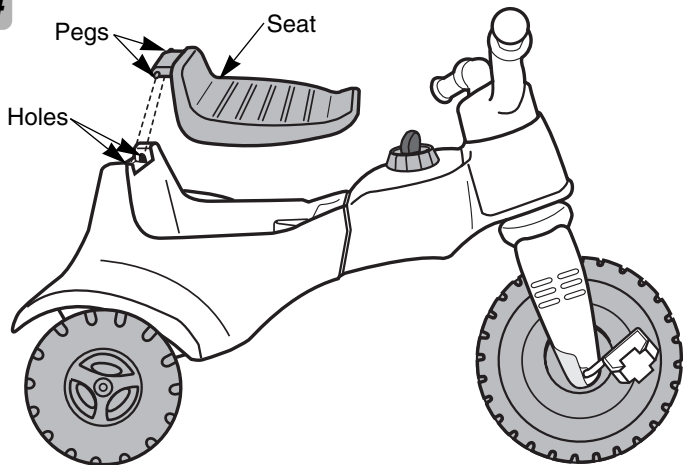
14

- At an angle, insert one peg on the back of the seat into the hole in the top rear of the frame.
- Insert and “**snap**” the other peg on the back of the seat into the other hole in the top rear of the frame.

One-time assembly is now complete.

Label Decoration

Proper label application will help to keep the labels looking their best!

- Wash your hands before applying the labels.
- Make sure the areas where the labels will be applied are clean and dry. Wipe your vehicle with a clean, soft, dry cloth to remove any dust or oils.
- For best results, avoid applying a label more than once.
- Apply the labels as shown in the illustrations below.
- After applying a label, rub the label firmly with a cloth to make sure the label is adhered to your vehicle.

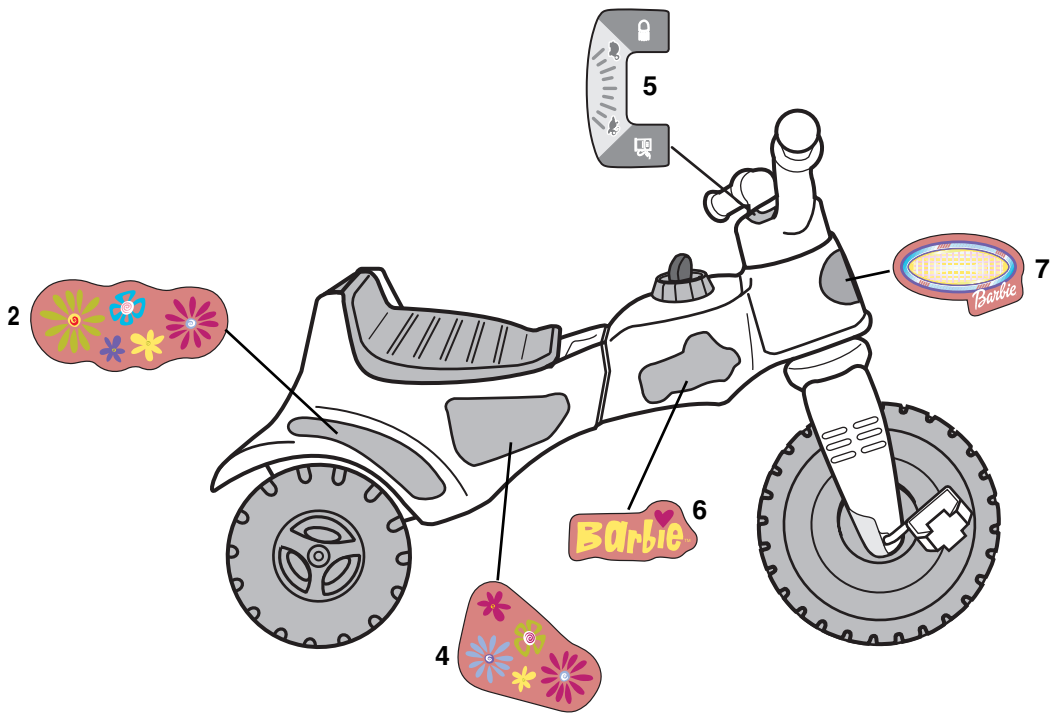

Right Side

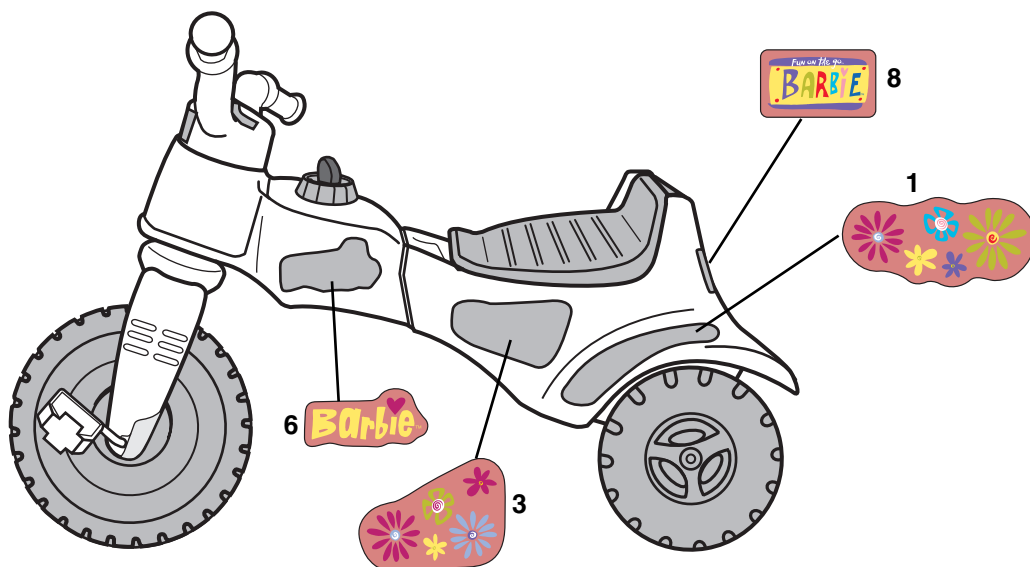

Left Side

Maintenance

- Check plastic parts regularly and if broken or cracked, dispose of them properly.
- Check all fasteners regularly to be sure they are tight. If the fasteners are not tight, tighten them as necessary.
- To clean the trike, use a mild soap and water solution and a clean cloth. Rinse clean with water to remove soap residue.

Consumer Information



Questions? We'd like to hear from you!

Call Consumer Relations, toll-free at **1-800-432-KIDS**, 8 AM - 6 PM EST Monday through Friday. Hearing-impaired consumers using TTY/TDD equipment, please call 1-800-382-7470. Or, write to: Consumer Relations, 636 Girard Avenue, East Aurora, New York 14052.

www.fisher-price.com

If you have any questions about this product:

In Canada, call **1-800-567-7724**, or write to: Mattel Canada Inc, 6155 Freemont Blvd., Mississauga, Ontario L5R 3W2.

In Great Britain, telephone 01628 500303.

In Australia, Mattel Australia Pty. Ltd., 658 Church Street, Locked Bag #870, Richmond, Victoria 3121 Australia. Consumer Advisory Service 1-800-800-812 (valid only in Australia).