



SOUNDS 'N LIGHTS PORTABLE ENTERTAINER™

Model Number: 79070

INSTRUCTIONS



Please read and understand these instructions before assembly and use.

Keep these instructions for future reference.

Tool needed for assembly: Phillips Screwdriver (not included).

Maximum weight limit: 26 lbs.

www.fisher-price.com

WARNINGS



WARNING

To prevent serious injury or death:

- Use only for a child who is able to hold head upright unassisted and who is not able to walk.
- Never leave child unattended. Always keep child in view while in product.
- Never use near steps or pools, hot surfaces or areas that may be hazardous to a child. Product may move during use.
- To avoid tip over, place product on a flat, level surface.

CONSUMER INFORMATION

Occasionally a consumer may experience a problem with one of our products. If this should happen, please call us toll-free, rather than return this product to the store. Usually we can solve the problem on the telephone or by sending you replacement parts. Please call Fisher-Price® Consumer Relations, toll-free at **1-800-432-KIDS**, 8 AM - 6 PM EST Monday through Friday. Hearing-impaired consumers using TTY/TDD equipment, please call 1-800-382-7470. Or, write to: Fisher-Price® Consumer Relations, 636 Girard Avenue, East Aurora, New York 14052.

PARTS

IMPORTANT! Please remove all parts from the package and identify them before assembly.

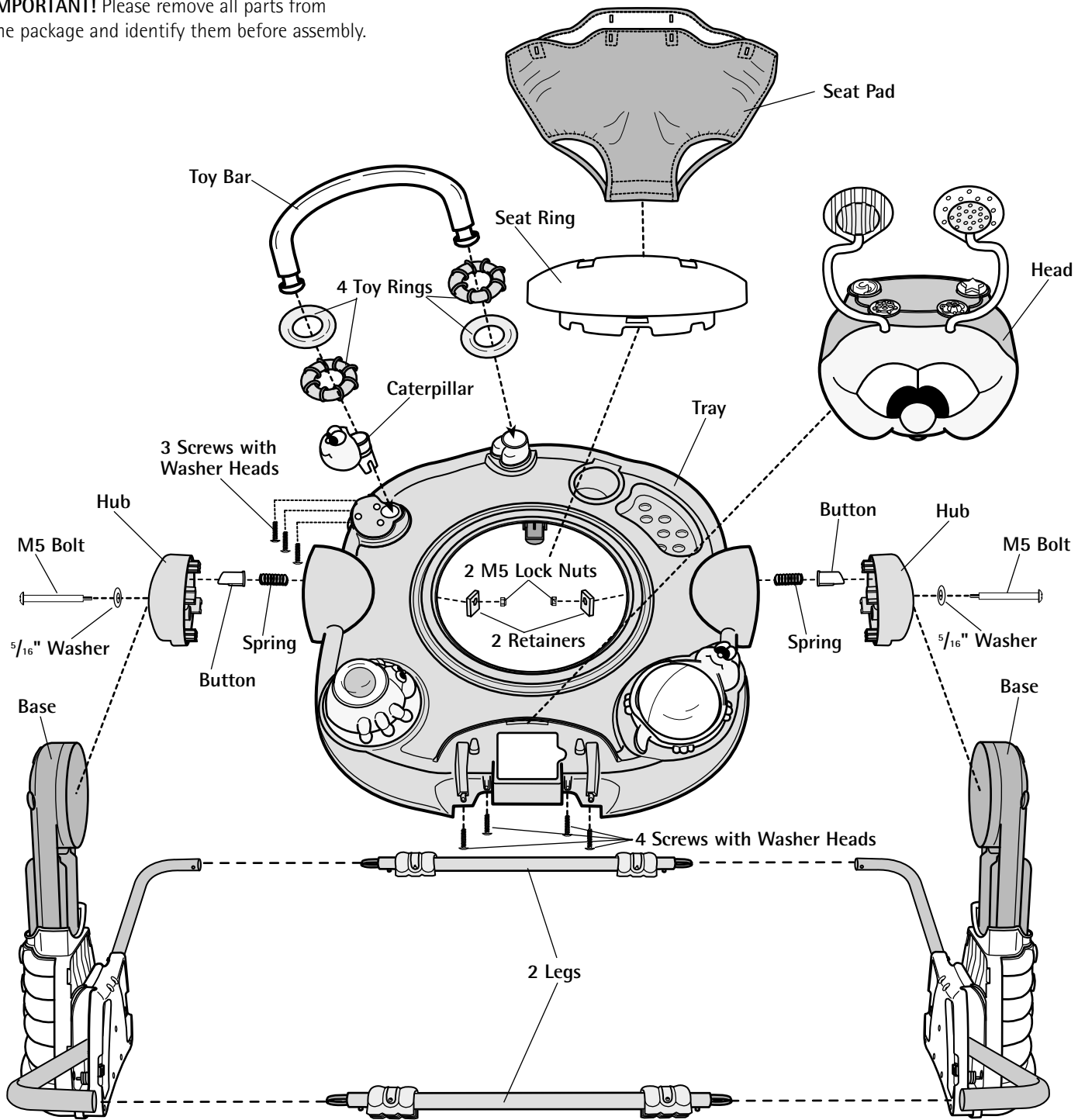

M5 3⁹/₁₆" Bolt - 2
SHOWN ACTUAL SIZE

5¹⁶/₁₆" Washer - 2
SHOWN ACTUAL SIZE

M5 Lock Nut - 2
SHOWN ACTUAL SIZE

5⁸/₈" Screw with Washer Head - 7
SHOWN ACTUAL SIZE

ASSEMBLY

IMPORTANT! Before each use or assembly, inspect this product for damaged hardware, loose joints, missing parts or sharp edges. Do not use if any parts are missing or broken. Contact Fisher-Price® for replacement parts and instructions needed. Never substitute parts.

CAUTION

This product contains small parts in its unassembled state.
Adult assembly is required.

1

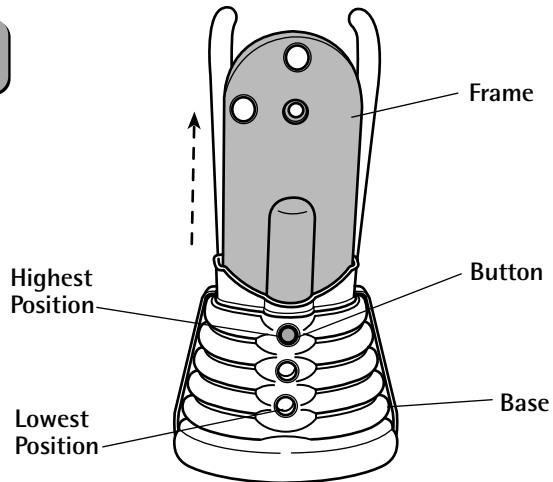

- Place a base on a flat surface.
- While pressing the button on the side of the base, lift the frame to the highest position. The button should be in the highest position.
- Repeat this procedure to raise the other frame on the other base to its highest position.
- Make sure the button on each base is in the highest position.

2

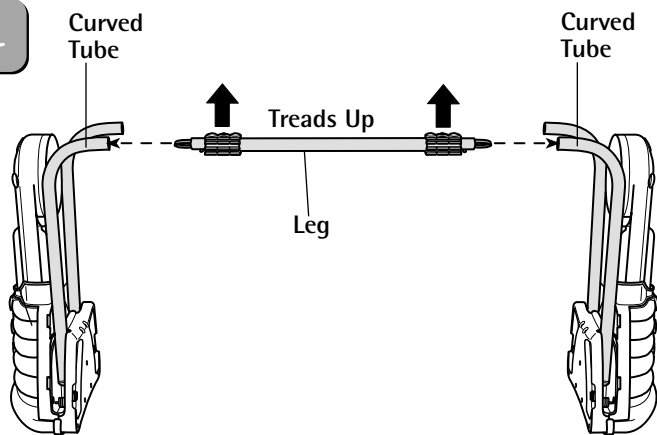

- Position a leg so that the buttons are down and the treads on the rubber feet face up.
- While pressing the buttons on the leg, insert and "snap" the ends of the leg into the curved tubes on the base.
- Repeat this procedure to attach the other leg to the bases.

3

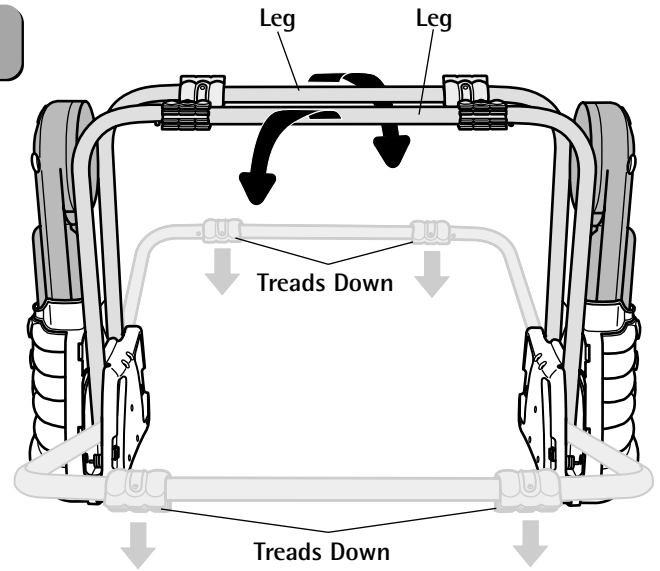

- Rotate the legs down.
- Make sure the treads on all four rubber feet are facing down. If the treads on all four rubber feet are not facing down, you have assembled the legs incorrectly. Remove the legs from the curved tubes (press the buttons on the legs to release them from the curved tubes) and re-read and repeat step 2.

4

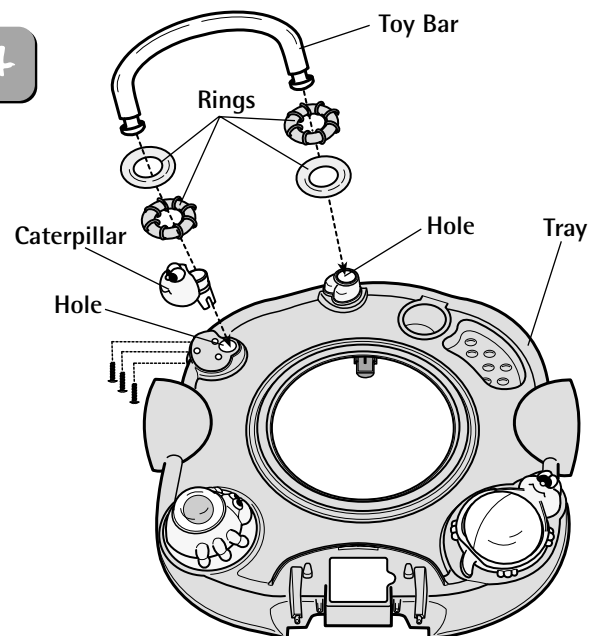

- Place the tray upright on a flat surface.
- Fit the caterpillar to the top of the tray. From the bottom of the tray, insert three $\frac{5}{8}$ " screws with washer heads through the tray and into the caterpillar. Tighten the screws with a Phillips screwdriver. Do not over-tighten.
- Slide the four rings onto the toy bar.
- Insert and "snap" the toy bar into the holes in the tray.
- Pull up on the toy bar to make sure it is secure.

ASSEMBLY

5

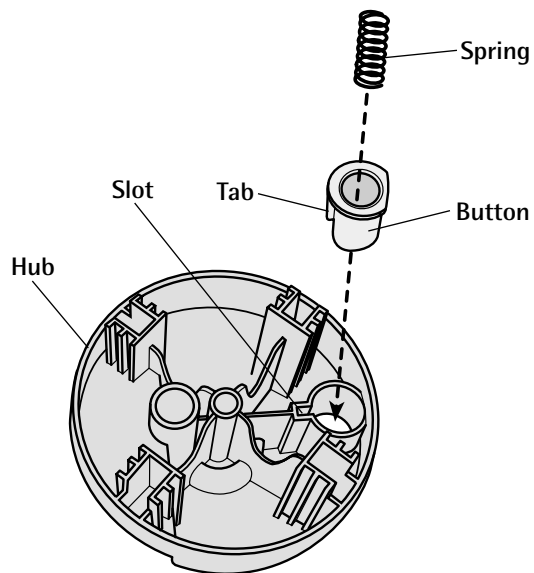

- Position the hub with the inside facing up.
- Align the tab on the button with the slot in the hub.
- Fit the button into the hub.
- Place a spring inside the button.
- Repeat this procedure to assemble the other button and spring to the other hub.

6

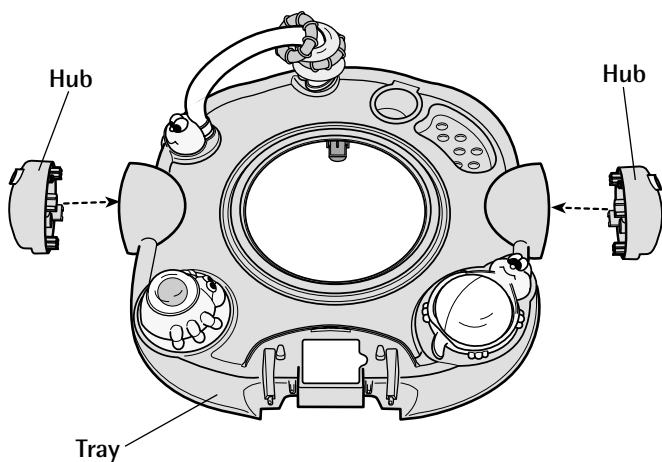

- Fit the hubs to each side of the tray.
- Hold the hubs in place.

7

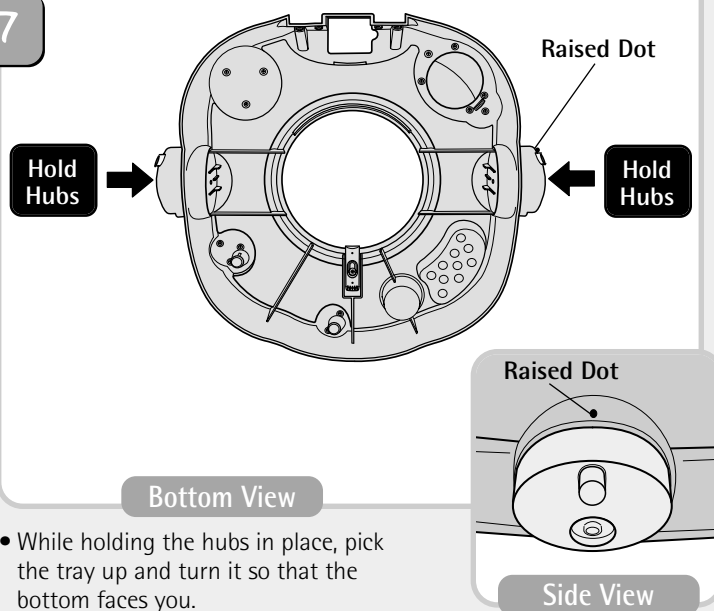

- While holding the hubs in place, pick the tray up and turn it so that the bottom faces you.
- Locate the raised dot on one side of the tray, near the hub.

8

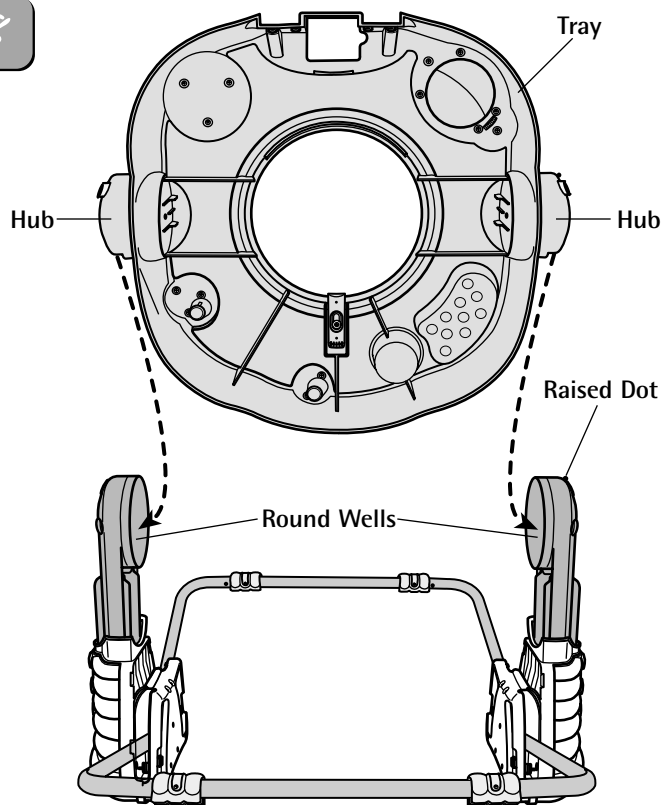

- Locate the raised dot on one of the frames.
- Align the raised dot on the tray with the raised dot on the frame.
- Fit the hubs into the round wells in the frames.

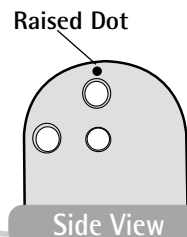

ASSEMBLY

9

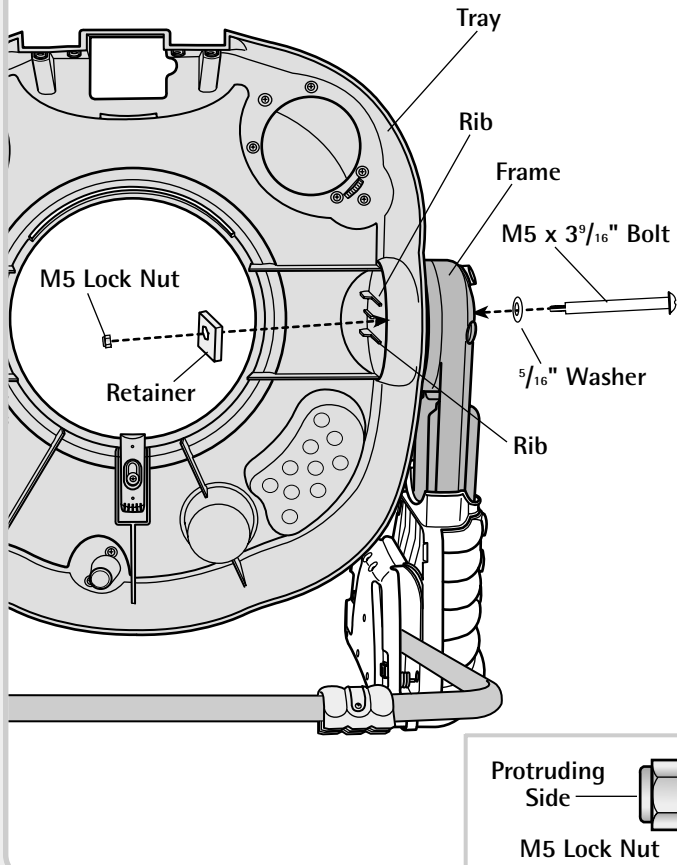

- Slide a retainer between the two ribs on one side of the tray, as shown.
- Fit an M5 lock nut (**protruding side facing away from the retainer**) into the hexagonal hole in the retainer.
- Fit a $\frac{5}{16}$ " washer onto the M5 bolt. Insert the M5 bolt through the frame, hub, tray and into the retainer. Tighten the bolt with a Phillips screwdriver. Do not over-tighten.
- Repeat this procedure to fasten the other side of the tray to the other frame.

10

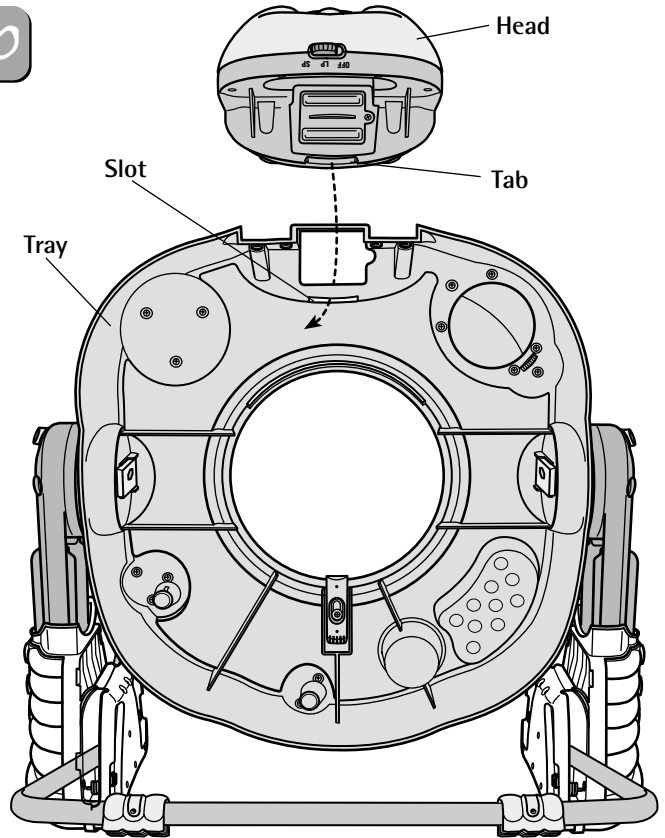

- Position the head with the face upright.
- Insert and snap the tab on the head into the slot in the tray.

11

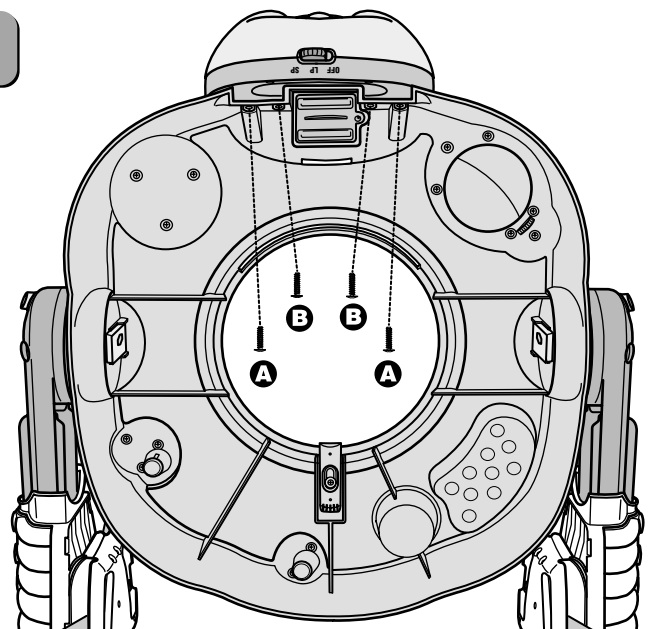

- Insert two $\frac{5}{8}$ " screws with washer heads through the front holes **A** in the tray and into the head. Tighten the screws with a Phillips screwdriver. Do not over-tighten.
- Insert two $\frac{5}{8}$ " screws with washer heads through the back holes **B** in the tray and into the head. Tighten the screws with a Phillips screwdriver. Do not over-tighten.

ASSEMBLY

12

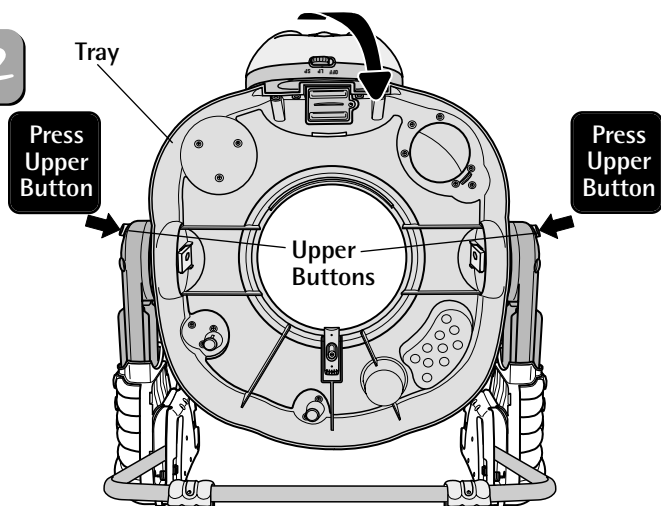

- While pressing the upper buttons on both sides of the base, rotate the tray down until it "snaps" into position. Make sure you hear a "snap".

IMPORTANT! If the tray does not "snap" into position, you have assembled the tray to the frame backwards. Remove the M5 bolt, retainer and M5 lock nut from the frame and tray. Carefully lift the tray from the round wells in the frame. Re-read and repeat Assembly steps 7-9.

14

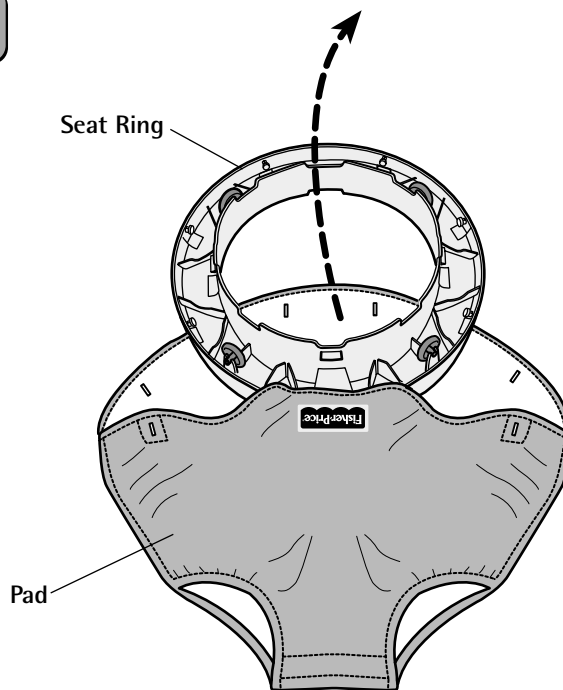

13

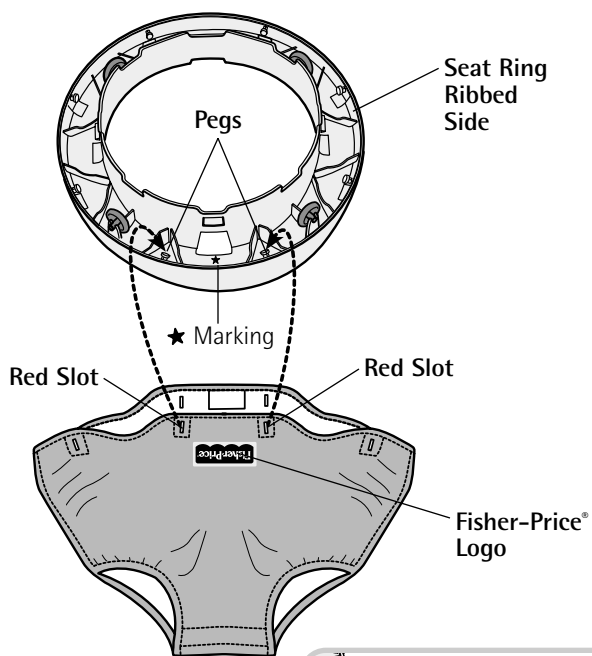

- Position the seat ring so that the inside (ribbed side) is up and the ★ marking is toward you.
- Position the pad so that the Fisher-Price® logo is facing you (although it will be upside down!)
- Fit the red slots on the pad (next to the Fisher-Price® logo) to the seat ring pegs on either side of the ★ marking, as shown.

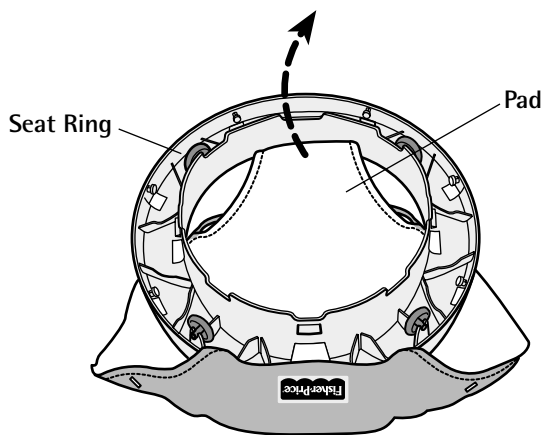
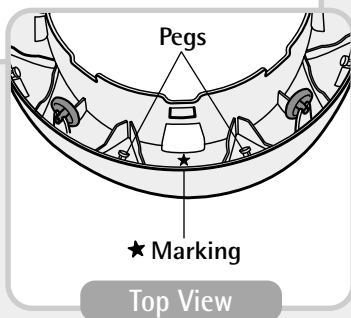

- Pull the pad through the seat ring and wrap the pad around the outside of the seat ring.

ASSEMBLY

15

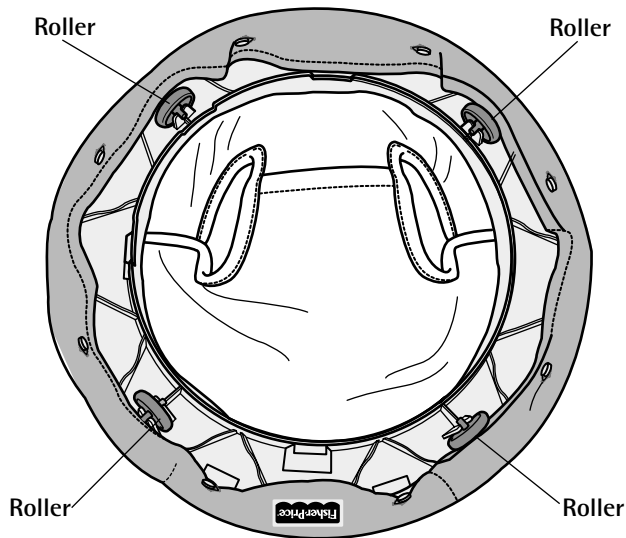
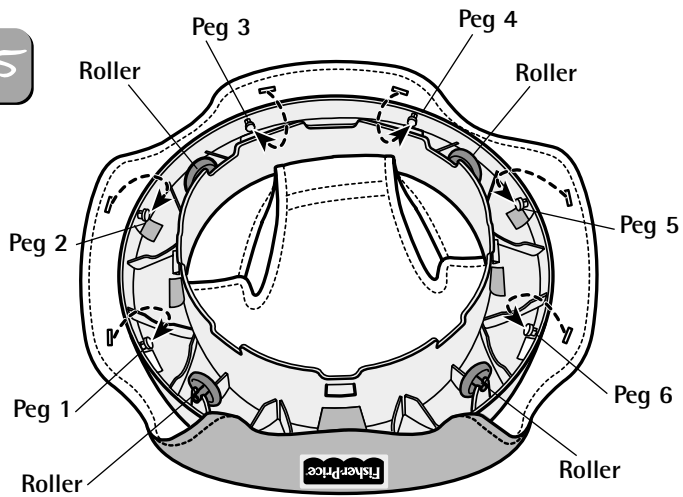

- Fit the other six slots in the seat pad to the corresponding pegs on the seat ring.
- Tuck the seat pad behind all four rollers.

16

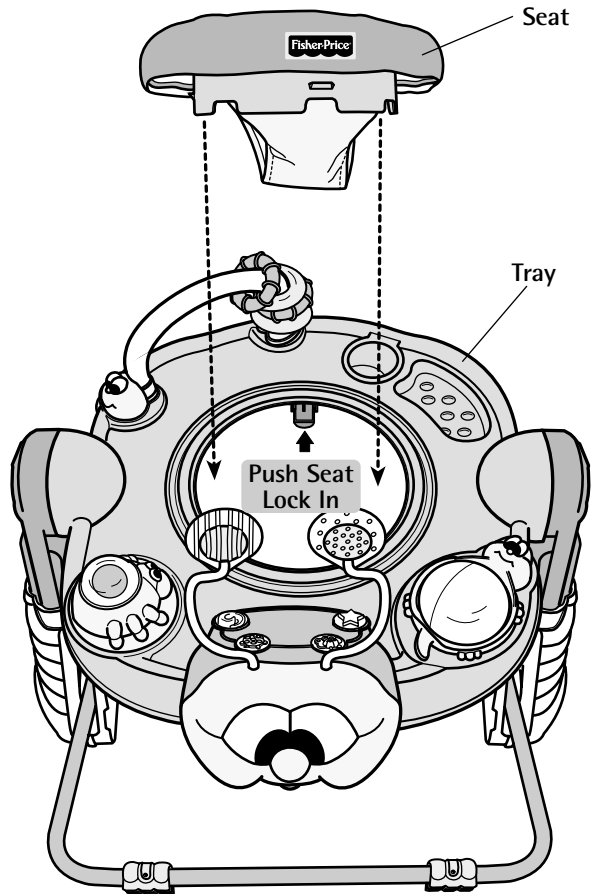

- Push the seat lock to the unlocked position.
- Insert and "snap" the seat into the hole in the tray.

IMPORTANT! Assembly is now complete, but you will still need to properly setup this product for use. Please refer to the Battery Installation section and the Operation and Use section, beginning with step 3 for additional instructions.

BATTERY INSTALLATION

1

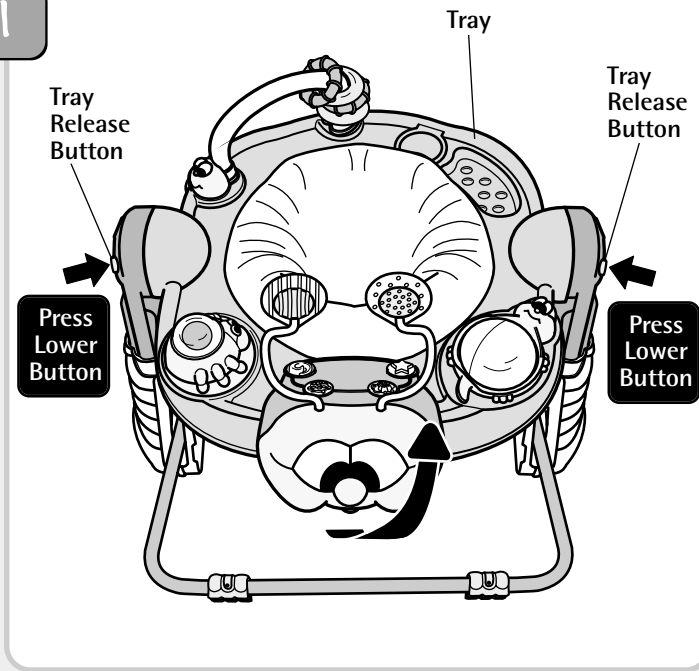

- Face the front of the product
- While pressing the tray release button (lower button) on each side of the base, rotate the tray up.

2

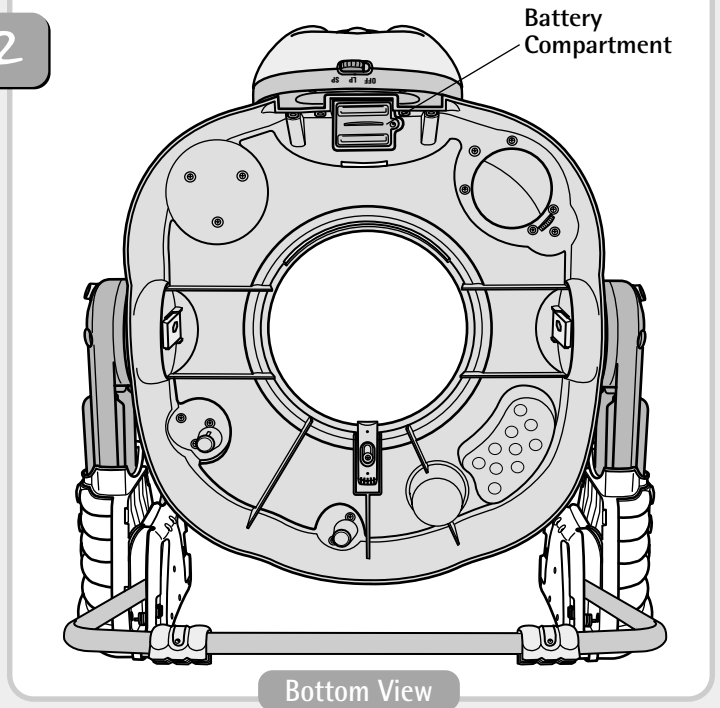

- Locate the battery compartment on the bottom of the tray.
- Loosen the screw in the battery compartment door with a Phillips screwdriver.
- Remove the battery compartment door.

BATTERY INSTALLATION

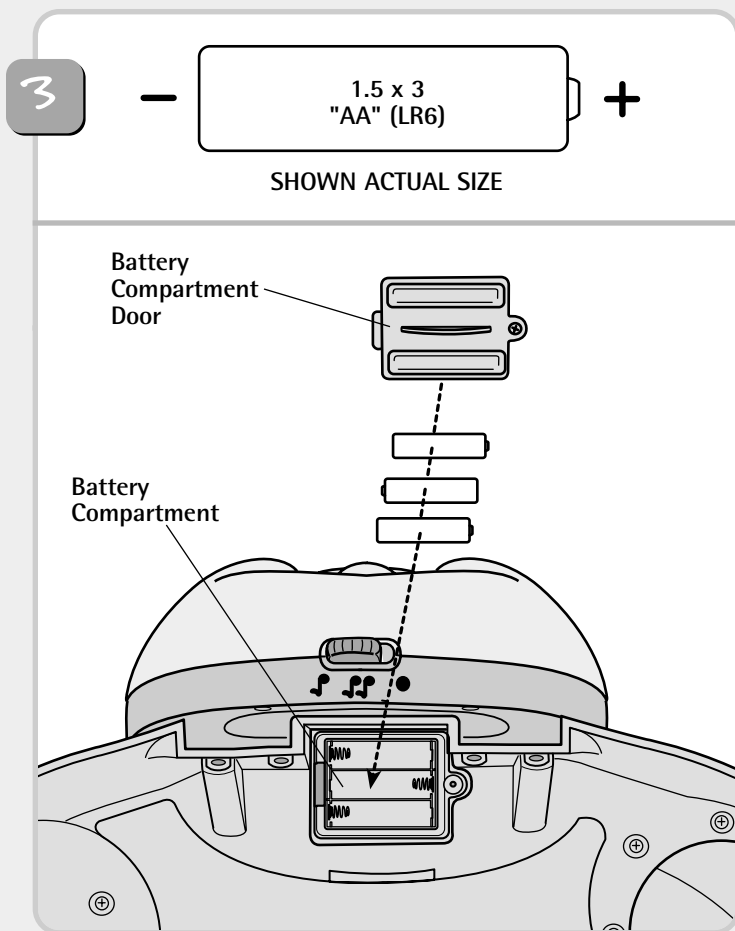

- Insert three "AA" (LR6) alkaline batteries as shown inside the battery compartment.

Hint: Use only alkaline batteries for longest battery life.

- Replace the battery compartment door and tighten the screw with a Phillips screwdriver. Do not over-tighten.

Battery Tips

- Do not mix old and new batteries.
- Do not mix different types of batteries: alkaline, standard (carbon-zinc) or rechargeable (nickel-cadmium).
- Remove the batteries during long periods of non-use. Always remove exhausted batteries from the product. Battery leakage and corrosion can damage this product. Dispose of batteries safely.
- Never short circuit the battery terminals.
- Non-rechargeable batteries are not to be recharged.
- Only batteries of the same or equivalent type as recommended in the Battery Installation instructions are to be used.
- If removable rechargeable batteries are used, they are only to be charged under adult supervision.
- Rechargeable batteries are to be removed from the toy before they are charged.
- If you use a battery charger, it should be examined regularly for damage to the cord, plug, enclosure and other parts. Do not use a damaged battery charger until it has been properly repaired.

IMPORTANT! If sounds and/or lights become faint, or there are no sounds or lights, remove the batteries and dispose of them properly. Replace the batteries with three, new "AA" (LR6) alkaline batteries.

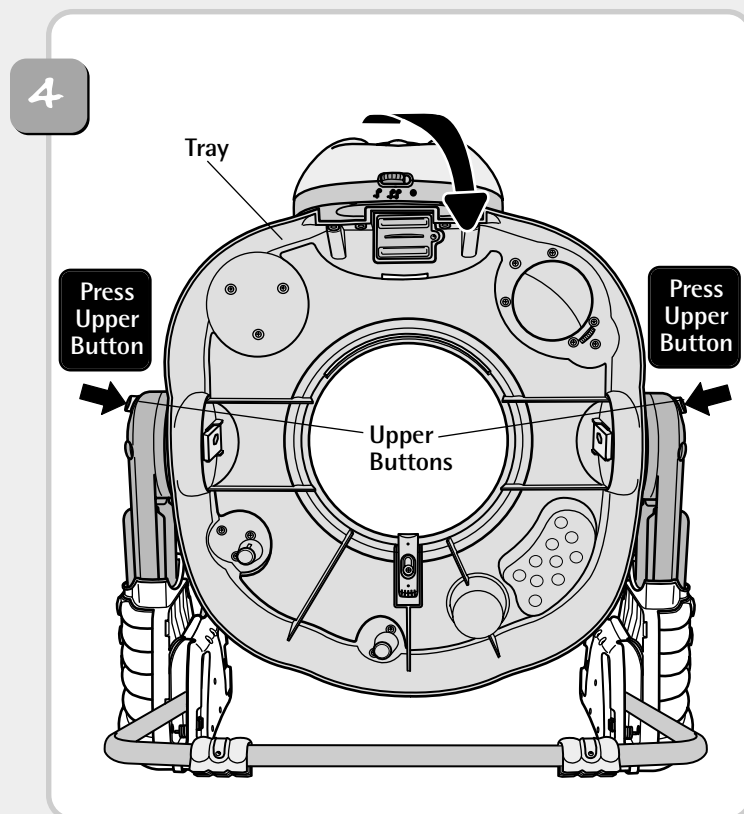

- Face the front of the product
- While pressing the tray release buttons (upper buttons) on both sides of the base, rotate the tray down until it "snaps" into position. **Make sure you hear a "snap".**

OPERATION AND USE

IMPORTANT! Before each use or assembly, inspect this product for damaged hardware, loose joints, missing parts or sharp edges. Do not use if any parts are missing or broken. Contact Fisher-Price® for replacement parts and instructions if needed. Never substitute parts.

Setup



WARNING

To prevent serious injury or death:

- Never use near steps or pools, hot surfaces or areas that may be hazardous to a child. Product may move during use.
- To avoid tip over, place product on a flat, level surface.

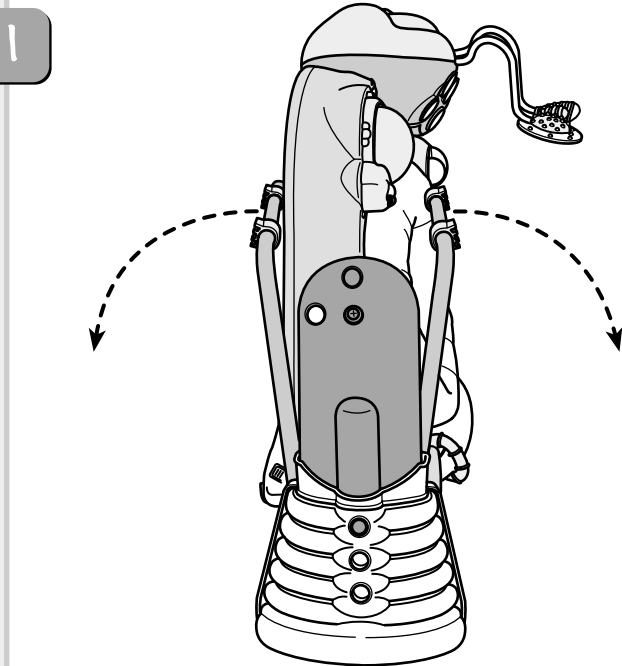

- Place the product on a flat, level surface.
- Rotate the legs down.

IMPORTANT! The legs are not yet locked in place. Please proceed with setup steps 2-5.

2

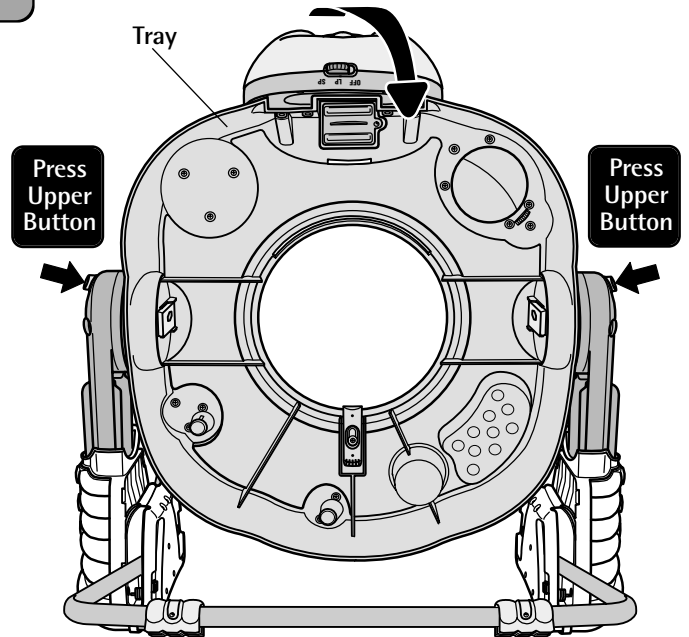

- Face the front of the product.
- While pressing the tray release buttons (upper buttons) on each side of the base, rotate the tray down until it "snaps" into place. **Make sure you hear a "snap"**.

3

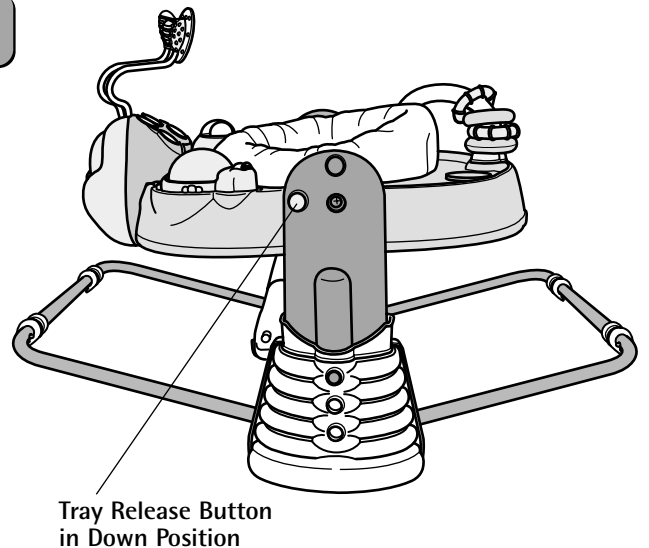

- Check to be sure the tray is secure. The tray release button should be in the down position.

OPERATION AND USE

4

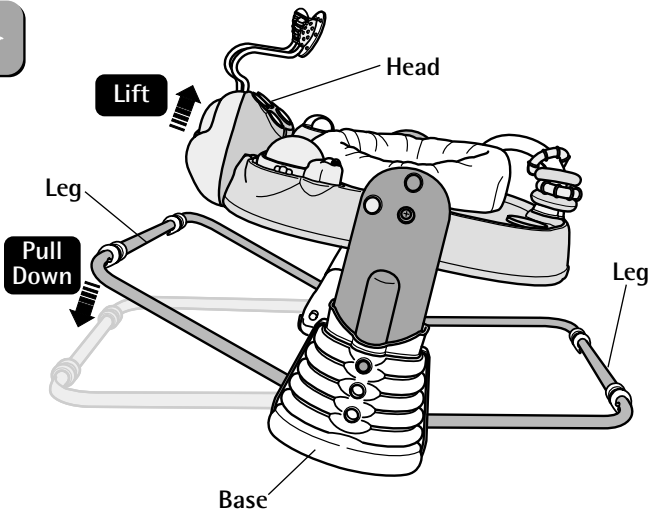

- While lifting the head, pull the leg down until it "snaps" into place. **Make sure you hear a "snap".**
- Repeat this procedure (this time lifting the back of the tray) to lock the other leg into place on the other side of the base.

5

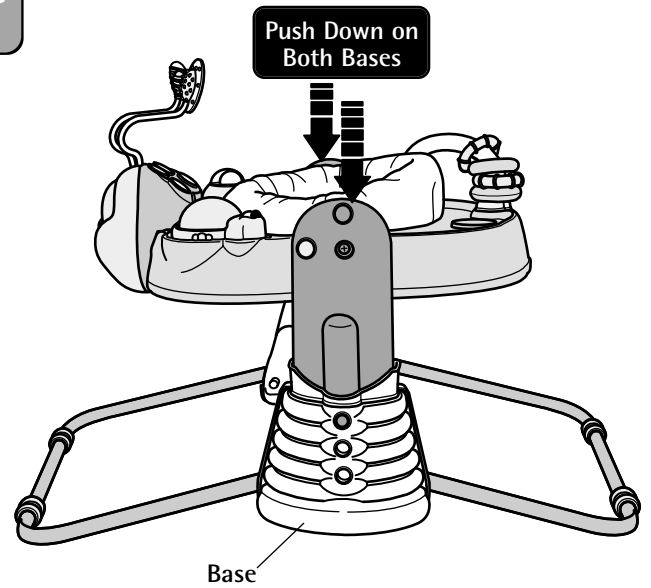

- Push down on both sides of the base to be sure the legs are locked into place.

OPERATION AND USE

Sounds and Lights!

6

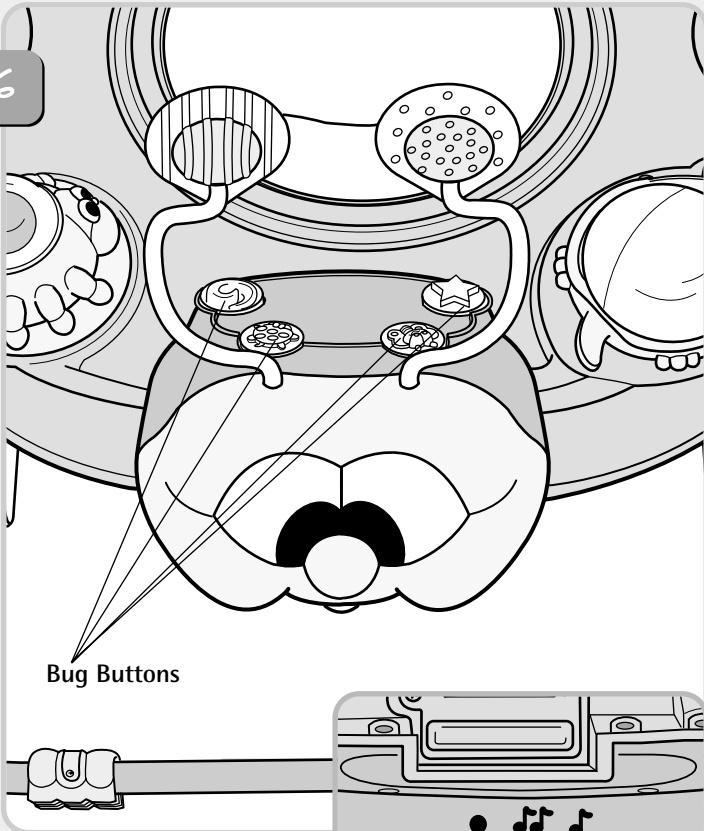

Bug Buttons

Power Switch

Long-Play Mode

- Slide the power switch to  for long-play mode. Baby delights to six songs and light patterns when a bug button is pressed.

Short-Play Mode

- Slide the power switch to  for short-play mode. Baby enjoys one song and a light pattern when a bug button is pushed.

Off

- Slide the power switch to  to turn off sound and lights.

IMPORTANT! If sounds and/or lights become faint, or there are no sounds or lights, remove the batteries and dispose of them properly. Replace the batteries with three, new "AA" (LR6) alkaline batteries.

Adjusting the Height

7

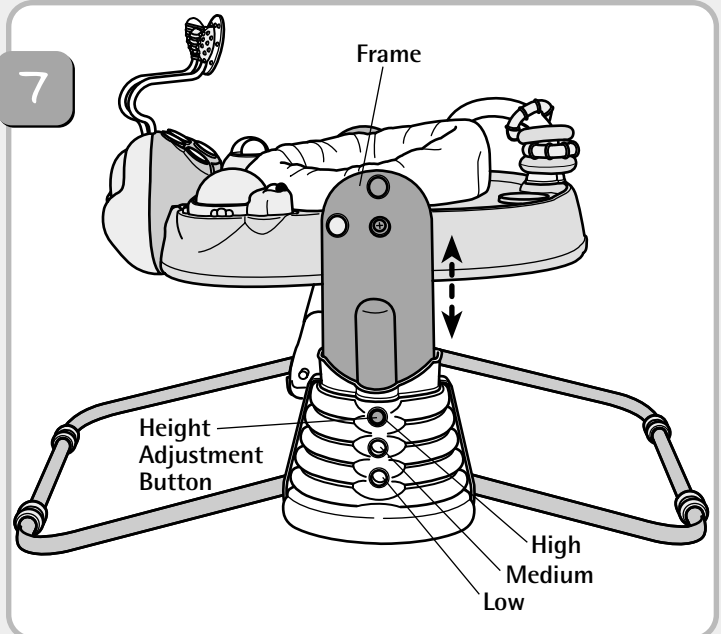

- You can adjust this product to three different heights for baby's comfort. Make sure baby's feet touch the floor.
- While pressing the height adjustment button on the side of the base, lift or lower the frame to the desired position.
- **Be sure to adjust the frame height on the other side of the base to the same height!**

Locking the Seat

8

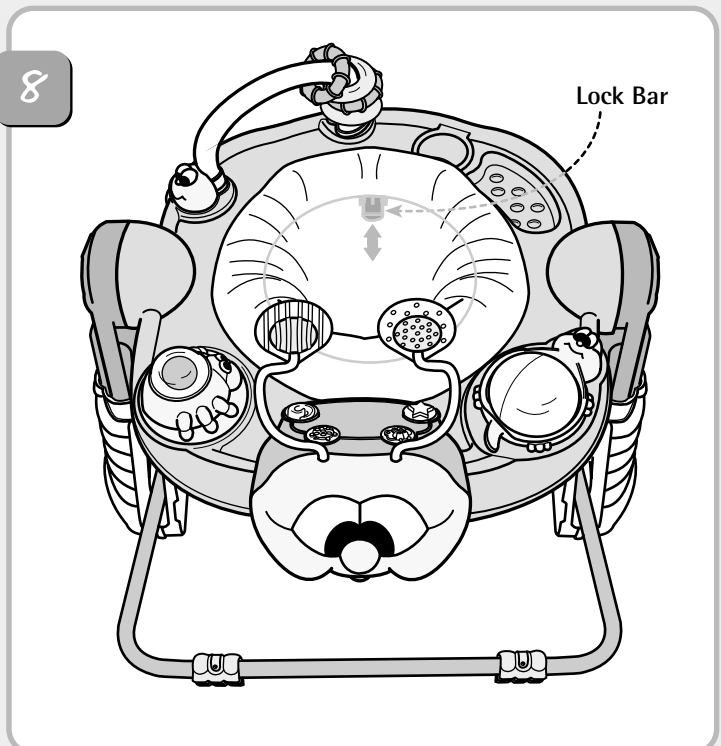

- Baby can turn in the seat or you can lock the seat into place.
- **To lock the seat:** Align a seat notch (located underneath the seat) with the lock bar and slide the lock bar in.
- **To unlock the seat:** Slide the lock bar out.

OPERATION AND USE

Storage

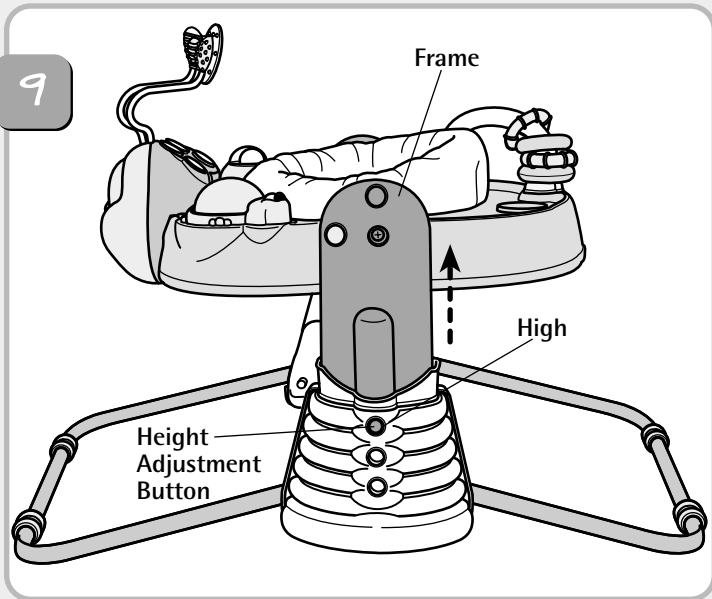

- You must adjust the height to the highest position for storage.
- While pressing the height adjustment button on the side of the base, lift the frame to the highest position.
- Be sure to adjust the frame height on the other side of the base to the highest position!

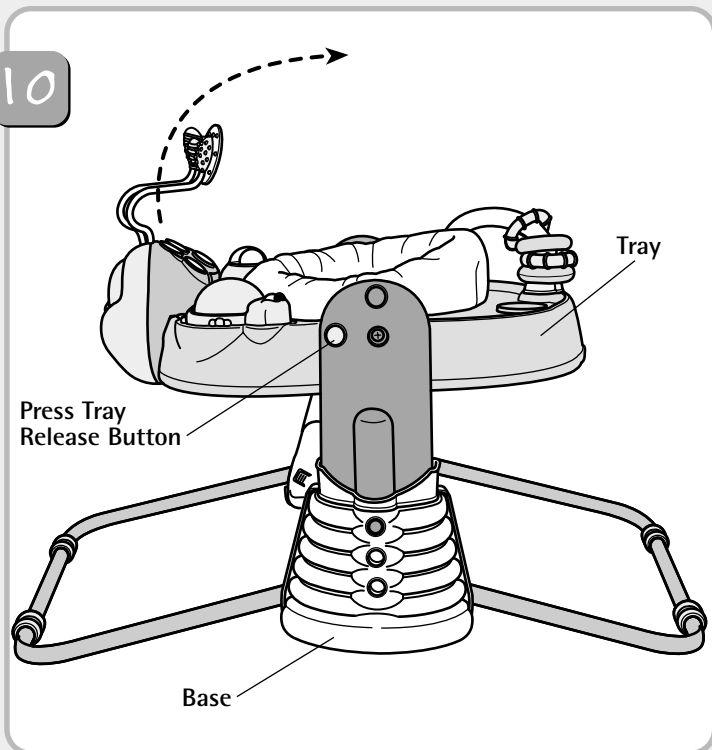

- Face the front of the product.
- While pressing the tray release button (lower button) on each side of the base, rotate the tray up until it "snaps" into place.

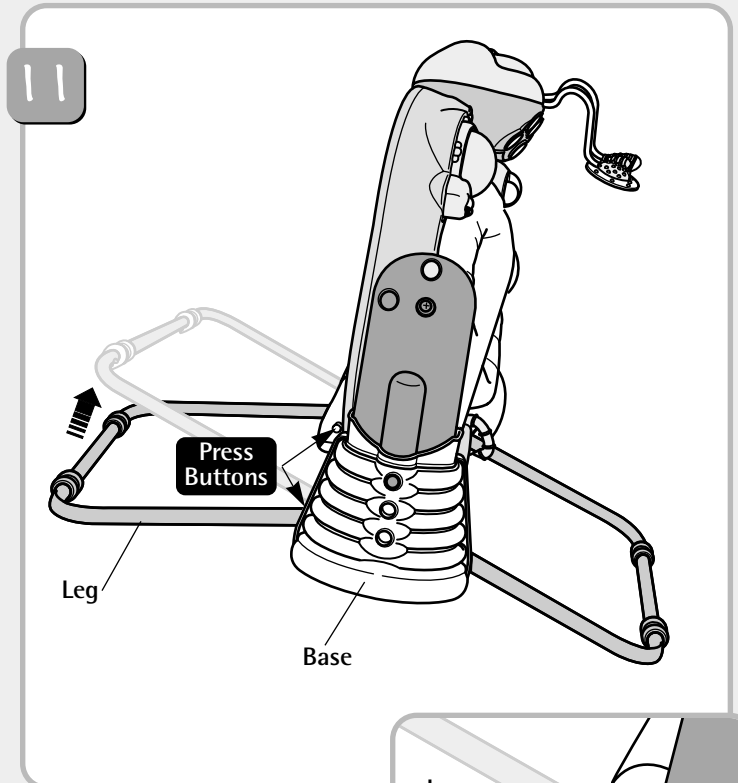

- Tip the product on one side and press the buttons on each side of the base to release the leg.
- Lift the leg slightly to the unlocked position.

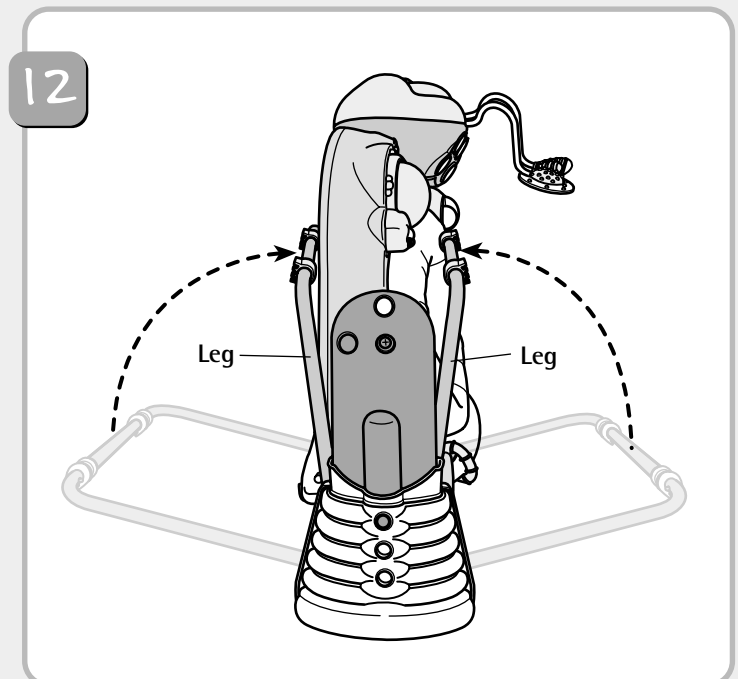
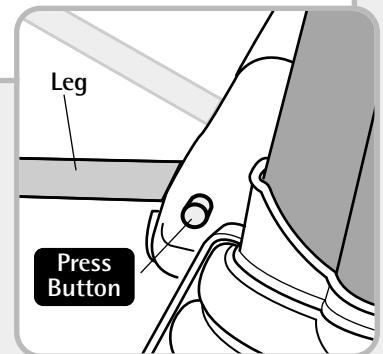

- Rotate the leg up.
- Repeat steps 11 and 12 to unlock and rotate the other leg up to the storage position.

CARE

- Machine wash the pad in cold water and a mild detergent. Do not use bleach. Tumble dry on low heat and remove promptly.
- Surface wash the base, tray and toys with mild detergent and water. Do not use bleach. Do not use harsh or abrasive cleaners. Rinse clean with water to remove residue. Do not immerse the tray.

To Remove the Pad

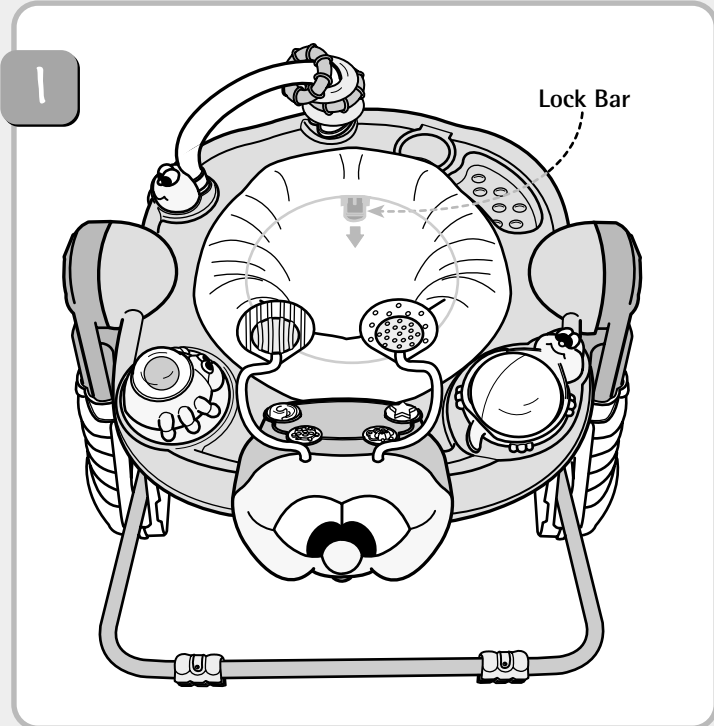

- Unlock the seat. Slide the lock bar out.

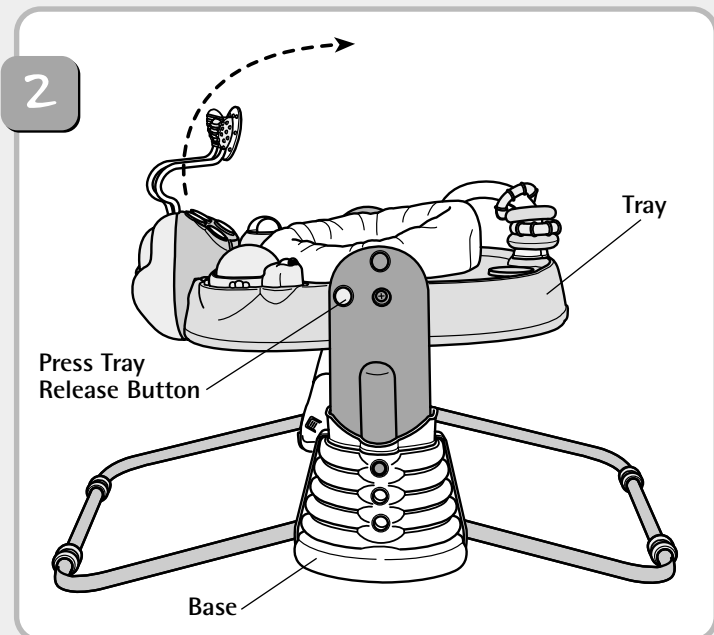

- Face the front of the product.
- While pressing the tray release button (lower button) on each side of the base, rotate the tray up until it "snaps" into place.

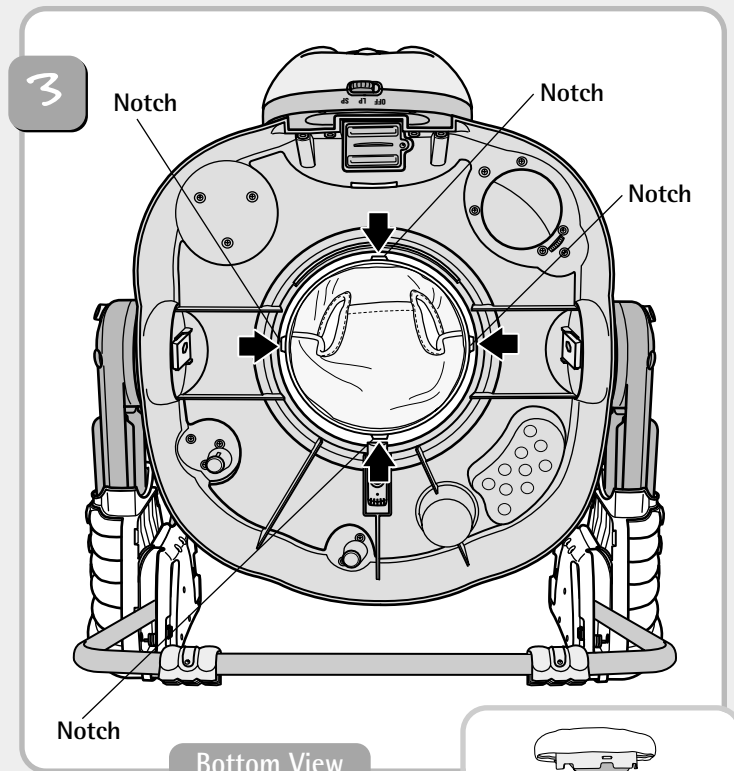

- While pressing near any notch on the seat ring, pull the seat ring from the tray.

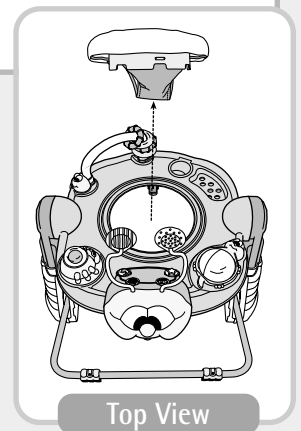

To Re-assemble the Pad

- Please refer to the Assembly section, steps 13-16.

ONE (1) YEAR LIMITED WARRANTY

Fisher-Price, Inc., 636 Girard Avenue, East Aurora, New York 14052 warrants Sounds 'n Lights Portable Entertainer™ is free from all defects in material and workmanship when used under normal conditions for a period of one (1) year from the date of purchase.

Should the product fail to perform properly, we will repair or replace it at our option, free of charge. Purchaser is responsible for shipping the product to Consumer Relations at the address indicated above and for all associated freight and insurance cost. Fisher-Price, Inc. will bear the cost of shipping the repaired or replaced item to you. This warranty is void if the owner repairs or modifies the product. This warranty excludes any liability other than that expressly stated above including but not limited to any incidental or consequential damages.

SOME STATES DO NOT ALLOW THE EXCLUSION OR LIMITATION OF INCIDENTAL OR CONSEQUENTIAL DAMAGES, SO THE ABOVE LIMITATION OR EXCLUSION MAY NOT APPLY TO YOU.

THIS WARRANTY GIVES YOU SPECIFIC LEGAL RIGHTS, AND YOU MAY ALSO HAVE OTHER RIGHTS WHICH MAY VARY FROM STATE TO STATE.

If you have any questions about this product: **In Canada**, call 1-800-567-7724, or write to: Mattel Canada Inc., 6155 Freemont Blvd., Mississauga, Ontario L5R 3W2.

In Great Britain, telephone 01628 500303.

In Australia, call the Fisher-Price Australian Consumer Advisory Service toll-free at 1-800-800-812, or write to: Mattel Pty. Ltd., 658 Church Street, Locked Bag #870, Richmond Victoria, 3121 Australia.