

# TO PLAY (A)

**1.** Lift lever up until it locks in place.

**2.** Clip mutant to the clamp. Make sure wheels are flush with the track.

**3.** Load car.

**4.** Press button to launch both vehicles.

Set up the VEHICLE RELEASE SWITCH as shown.

SIDE VIEW

**5.** Set up the TRAP DOOR SWITCH as shown.

**6.** Set up the DIVERTER SWITCH as shown.

RESET

NOTE: Cars cannot pass. Passage for mutants only.

# TO PLAY (B)

**1.** Repeat TO PLAY (A) steps 1, 2 and 3, then press button to launch both vehicles.

Set up the VEHICLE RELEASE SWITCH as shown.

SIDE VIEW

**2.** Set up the TRAP DOOR SWITCH as shown.

**3.a** Set up the DIVERTER SWITCH as shown.

NOT FOR USE WITH SOME HOT WHEELS® VEHICLES.

**3.b** Pull tab to open trap door.

RESET

# MORE WAYS TO PLAY

**HOT WHEELS TRACK SYSTEM**

CONNECT TO OTHER HOT WHEELS® SETS (SOLD SEPARATELY).

# PERFORMANCE TIPS

**Q.** After launching the mutant, it keeps falling off the track. What's wrong?

**A.** If the mutant is attached at an angle with one side off the track, it will not launch properly. Make sure wheels are flush with the track for proper performance.

©2014 Mattel. All Rights Reserved. Mattel, Inc., 636 Girard Avenue, East Aurora, NY 14052, U.S.A. Consumer Relations 1-800-524-8697. Mattel U.K. Ltd., Vanwall Business Park, Maidenhead SL6 4UB. Helpline 01628 500303. Mattel Australia Pty., Ltd., Richmond, Victoria, 3121. Consumer Advisory Service - 1300 135 312. Mattel East Asia Ltd., Room 503-09, North Tower, World Finance Centre, Harbour City, Tsimshatsui, HK, China. Diimport & Diedarkan Oleh: Mattel SEA Ptd Ltd. (993532-P) Lot 13.5, 13th Floor, Menara Lien Hoe, Persiaran Tropicana Golf Country Resort, 47410 P.J. Malaysia. Tel:03-78803817, Fax:03-78803867.

# INSTRUCTIONS

**HOT WHEELS**

**CITY**

**MUTANT MACHINES™**

**CITY ATTACK™**

**4+**

service.mattel.com  
**HOTWHEELS.COM**

**WARNING:**  
CHOKING HAZARD - Small parts.  
Not for children under 3 years.

**MATTEL**

B6J19-0920

PLEASE KEEP THESE INSTRUCTIONS FOR FUTURE REFERENCE AS THEY CONTAIN IMPORTANT INFORMATION.

# CONTENTS

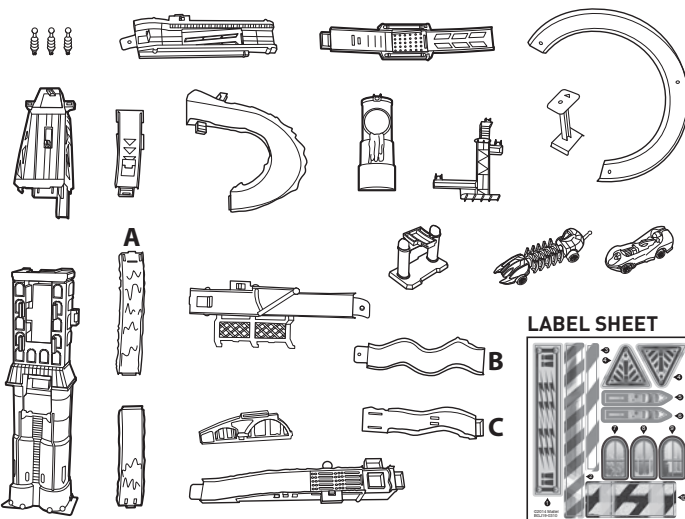

# APPLY LABELS

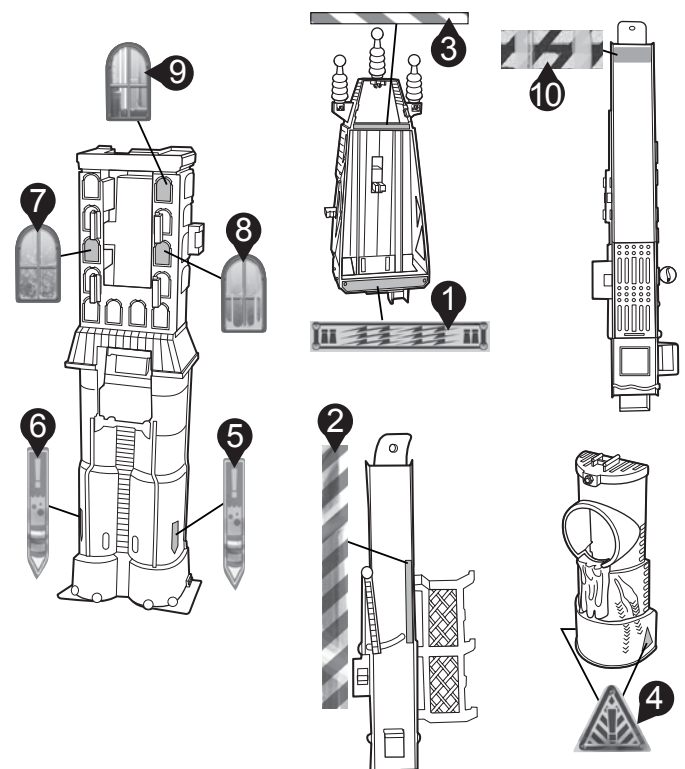

# ASSEMBLY

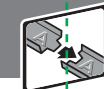

Refer to letter on toy parts and this page to help with assembly.

**1.1** **BACK VIEW** **A** **CLICK!**

**1.2**

**1.3** **BACK VIEW**

**2.1** **a** **b** **BOTTOM VIEW**

**2.2**

**2.3**

**3.1** **B**

**3.2** **c**

**3.3**

**3.4**

**3.5** **BOTTOM VIEW**

**3.6**

**3.7**

**3.8**

# SET UP

Set up the switches as shown in TO PLAY (A) and TO PLAY (B). Vary the combination of switches to mix up the action!

**VEHICLE RELEASE SWITCH**  
Releases car first. Releases mutant first.

**TRAP DOOR SWITCH**  
Locks trap door. Opens trap door.

**DIVERTER SWITCH**  
Locks the diverter. Activates the diverter.