

### TRACK LAYOUT

Once the towers and track are assembled:

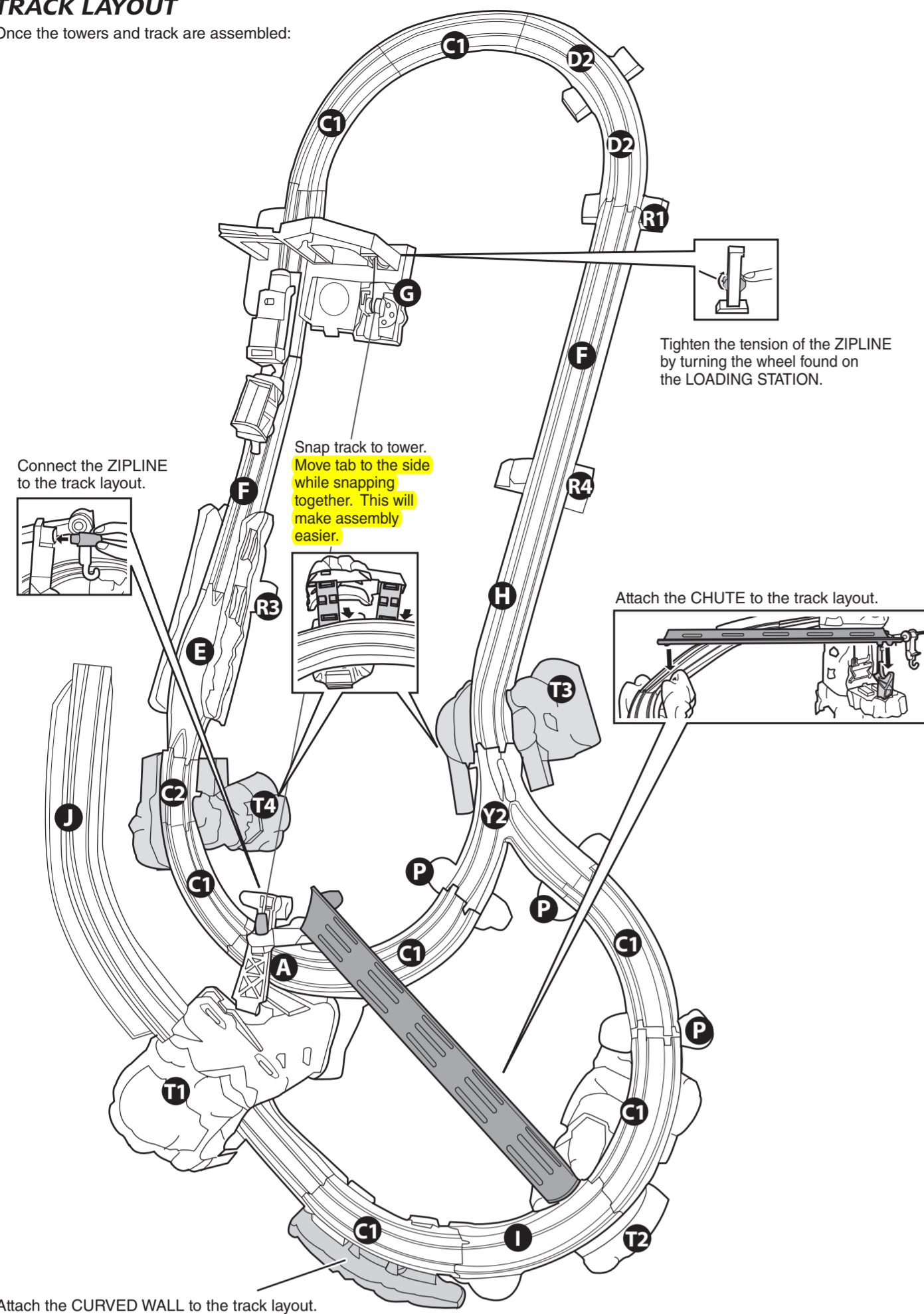

Connect the ZIPLINE to the track layout.

Snap track to tower. Move tab to the side while snapping together. This will make assembly easier.

Tighten the tension of the ZIPLINE by turning the wheel found on the LOADING STATION.

Attach the CHUTE to the track layout.

Attach the CURVED WALL to the track layout.

NOTE: Adults should remove & discard rubber bands holding tracks together.

### BATTERY INSTALLATION

Unscrew and lift cover away from top of Thomas. Install battery as indicated inside the battery compartment. For longer life use only alkaline batteries. Requires 1 AA (LR6) battery. If this toy begins to operate erratically, you may need to reset the electronics. Remove the batteries from the toy and replace it.

Thomas

Required tool:  
Phillips screwdriver (not included)

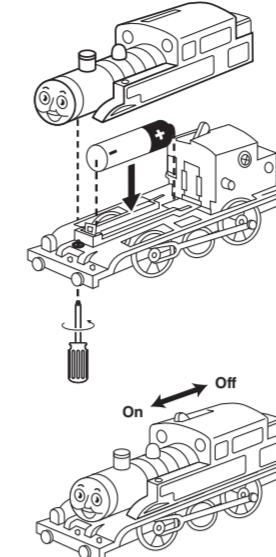

### BATTERY SAFETY INFORMATION

In exceptional circumstances batteries may leak fluids that can cause a chemical burn injury or ruin your product. To avoid battery leakage:  
 • Non-rechargeable batteries are not to be recharged.  
 • Rechargeable batteries are to be removed from the product before being charged.  
 • Rechargeable batteries are only to be charged under adult supervision.  
 • Do not mix alkaline, standard (carbon-zinc), or rechargeable (nickel-cadmium) batteries.  
 • Do not mix old and new batteries.  
 • Only batteries of the same or equivalent type as recommended are to be used.  
 • Batteries are to be inserted with the correct polarity.  
 • Exhausted batteries are to be removed from the product.  
 • The supply terminals are not to be short-circuited.  
 • Dispose of battery(ies) safely.  
 • Do not dispose of this product in a fire. The batteries inside may explode or leak.

This equipment has been tested and found to comply with the limits for a Class B digital device, pursuant to part 15 of the FCC rules. These limits are designed to provide reasonable protection against harmful interference in a residential installation. This equipment generates, uses and can radiate radio frequency energy and, if not installed and used in accordance with the instructions, may cause harmful interference to radio communications. However, there is no guarantee that interference will not occur in a particular installation. If this equipment does cause harmful interference to radio or television reception, which can be determined by turning the equipment off and on, the user is encouraged to try to correct the interference by one or more of the following measures:  
 • Reorient or relocate the receiving antenna.  
 • Increase the separation between the equipment and receiver.  
 • Connect the equipment into an outlet on a circuit different from that to which the receiver is connected.  
 • Consult the dealer or an experienced radio/TV technician for help.

NOTE: Changes or modifications not expressly approved by the manufacturer responsible for compliance could void the user's authority to operate the equipment.

This device complies with part 15 of the FCC Rules. Operation is subject to the following two conditions:  
 (1) This device may not cause harmful interference, and  
 (2) this device must accept any interference received, including interference that may cause undesired operation.

THIS CLASS B DIGITAL APPARATUS COMPLIES WITH CANADIAN ICES-003.  
 CET APPAREIL NUMÉRIQUE DE LA CLASSE B EST CONFORME À LA NORME NMB-003 DU CANADA.

Operation is subject to the following two conditions: (1) this device may not cause interference, and (2) this device must accept any interference, including interference that may cause undesired operation of the device.

L'utilisation de ce produit est soumise aux conditions suivantes: (1) il ne doit pas produire de brouillage et (2) il doit pouvoir tolérer tout brouillage reçu, même si ce brouillage est susceptible de compromettre son fonctionnement.

Protect the environment by not disposing of this product with household waste (2002/96/EC). Check your local authority for recycling advice and facilities.

NOTE: THE CARGO CAR INCLUDED IN THIS PLAYSET MAY NOT WORK WITH OTHER TRACKMASTER PLAYSETS.

**CONSUMER ASSISTANCE**  
 1-800-432-5437 (US & Canada)  
 1300 135 312 (Australia)  
**service.fisher-price.com**

Fisher-Price, Inc., 636 Girard Avenue, East Aurora, NY 14052.  
 Hearing-impaired consumers: 1-800-382-7470.

Outside the United States:  
 Canada: Mattel Canada Inc., 6155 Freemont Blvd., Mississauga, Ontario L5R 3W2; www.service.mattel.com.  
 Great Britain: Mattel UK Ltd, Vanwall Business Park, Maidenhead SL6 4UB; Helpline: 01628 500303; www.service.mattel.com/uk  
 Mattel Europa B.V., Gondel 1, 1186MJ Amstelveen, Nederland.  
 Australia: Mattel Australia Pty. Ltd., 658 Church Street, Locked Bag #870, Richmond, Victoria 3121 Australia.  
 New Zealand: 18-18 William Pickering Drive, Albany 1331, Auckland.

Thomas the Tank Engine & Friends™  
 CREATED BY BRITAIN ALLCROFT

Based on the Railway Series by The Reverend W Awdry.  
 ©2012 Gullane (Thomas) Limited.  
 Thomas the Tank Engine & Friends and Thomas & Friends are trademarks of Gullane (Thomas) Limited.  
 © HIT Entertainment Limited. HIT and the HIT logo are trademarks of HIT Entertainment Limited.  
 ©2012 Mattel. All Rights Reserved.  
 ® and ™ designate U.S. trademarks of Mattel, except as noted PRINTED IN CHINA.  
 Mattel East Asia Ltd., Room 1106, South Tower, World Finance Centre, Harbour City, Tsinghsatui, HK, China.

CAUTION:  
 To prevent entanglement, keep hair away from wheels.

W3542  
**Fisher-Price**



## RISKY RAILS BRIDGE DROP

### INSTRUCTIONS

Please keep these instructions for future reference as they contain important information.

**WARNING:**  
 CHOKING HAZARD - Toy contains small balls. Not for children under 3 years.



### Assembly

#### 1 TOWER 1 (9 pieces)

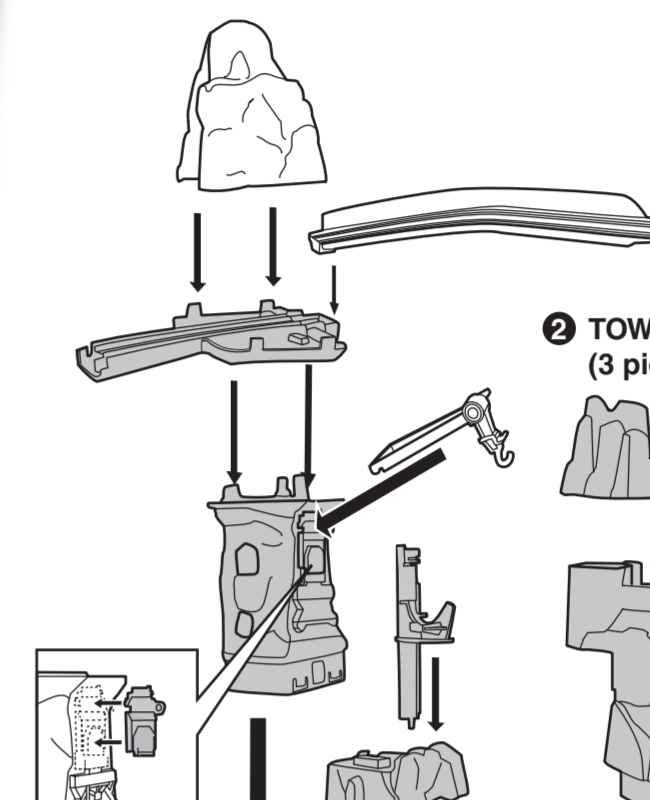

#### 2 TOWER 2 (3 pieces)

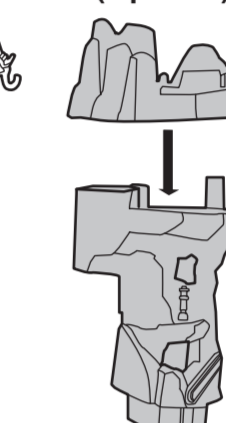

#### 3 LOADING STATION (2 pieces)

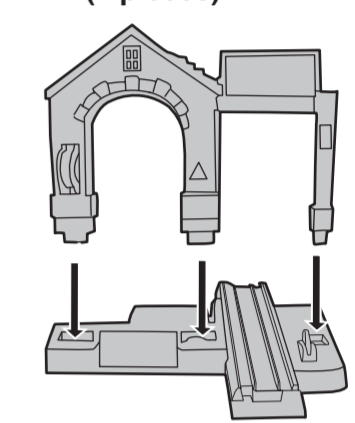

NOTE: All gray parts are "one-time snaps" - once they are put together, they cannot be taken apart.



**ADULT ASSEMBLY REQUIRED.** No tools required for assembly.

#### 4 TOWER 3 (3 pieces)

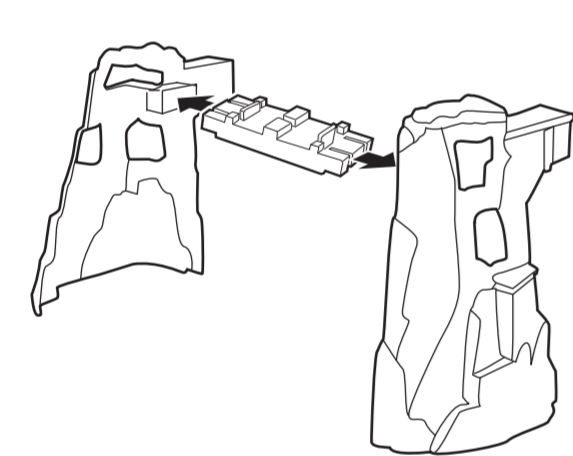

#### 5 TOWER 4 (4 pieces)

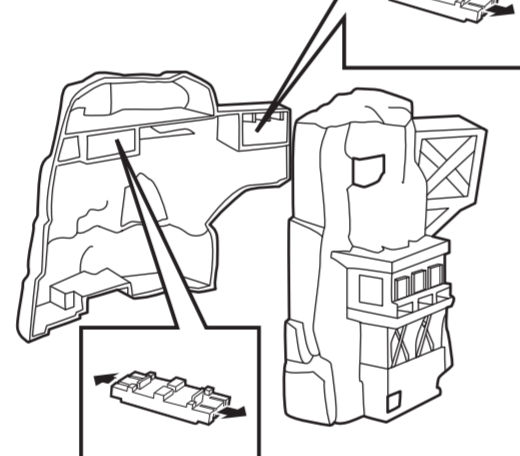

### HOW TO PLAY

1 Set both STOP/GO switches to the STOP position.

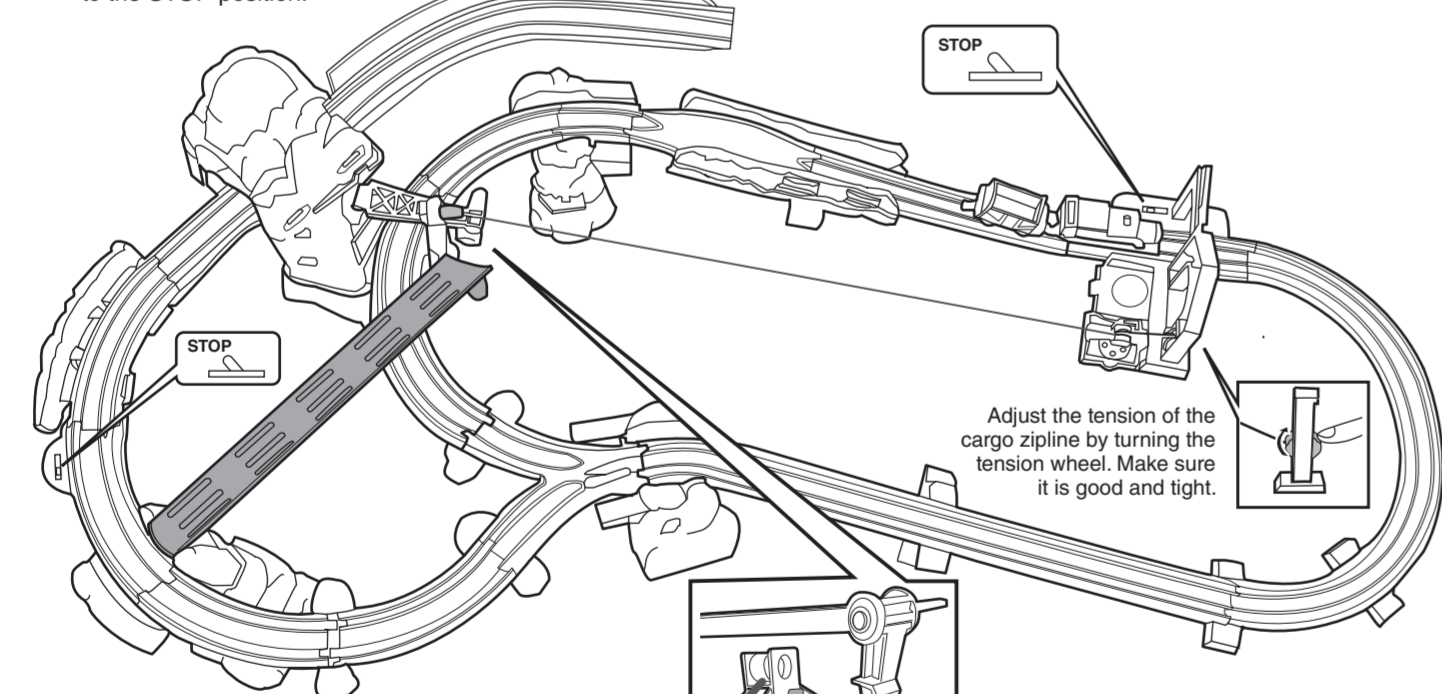

Adjust the tension of the cargo zipline by turning the tension wheel. Make sure it is good and tight.

2 Load the boulder into Thomas' cargo car. Start Thomas on his way to the upper level of the Blue Mountain Quarry.

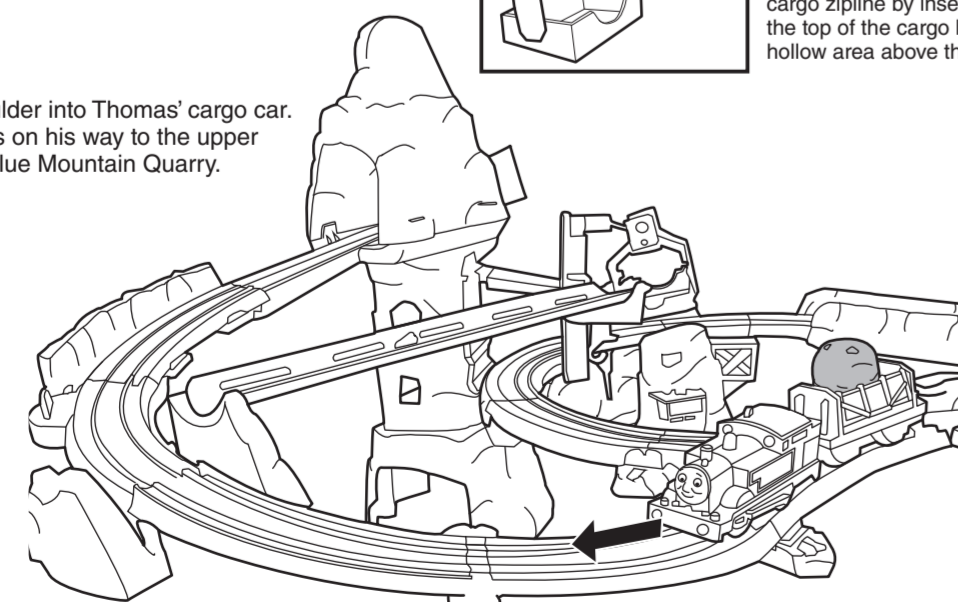

Set the cargo basket at the top of the cargo zipline by inserting the tab on the top of the cargo basket into the hollow area above the hook.

3 When Thomas stops at the top of the quarry, tip the cargo car and unload the boulder into the chute. The boulder will roll down the chute into the cargo basket.

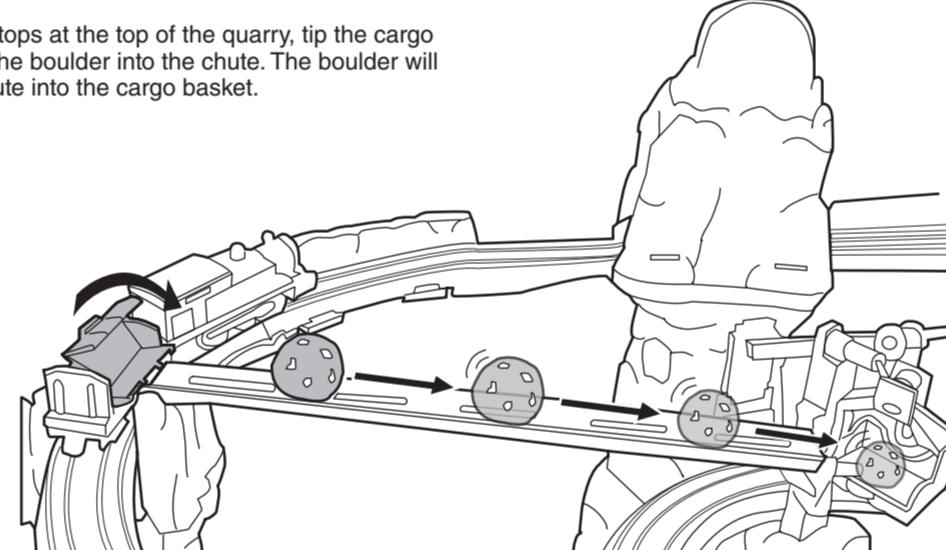

4 Once the boulder is in the cargo basket, release the cargo basket down the zipline by lifting the hook.

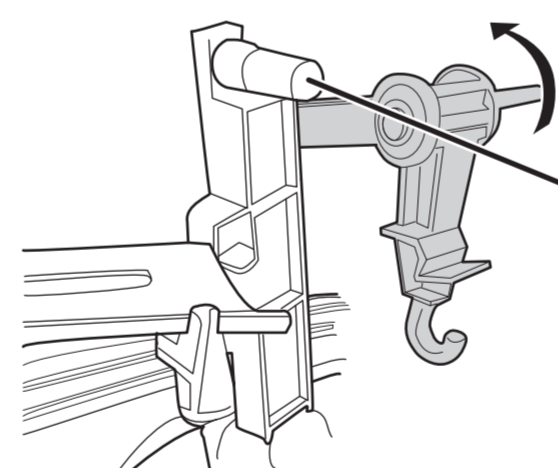

NOTE: If the basket doesn't make it all the way down the zipline, adjust the tension making the zipline tighter. (See STEP 1)

5 Set the STOP/GO switch at the top of Blue Mountain Quarry to the GO position and send Thomas down the bridge drop!

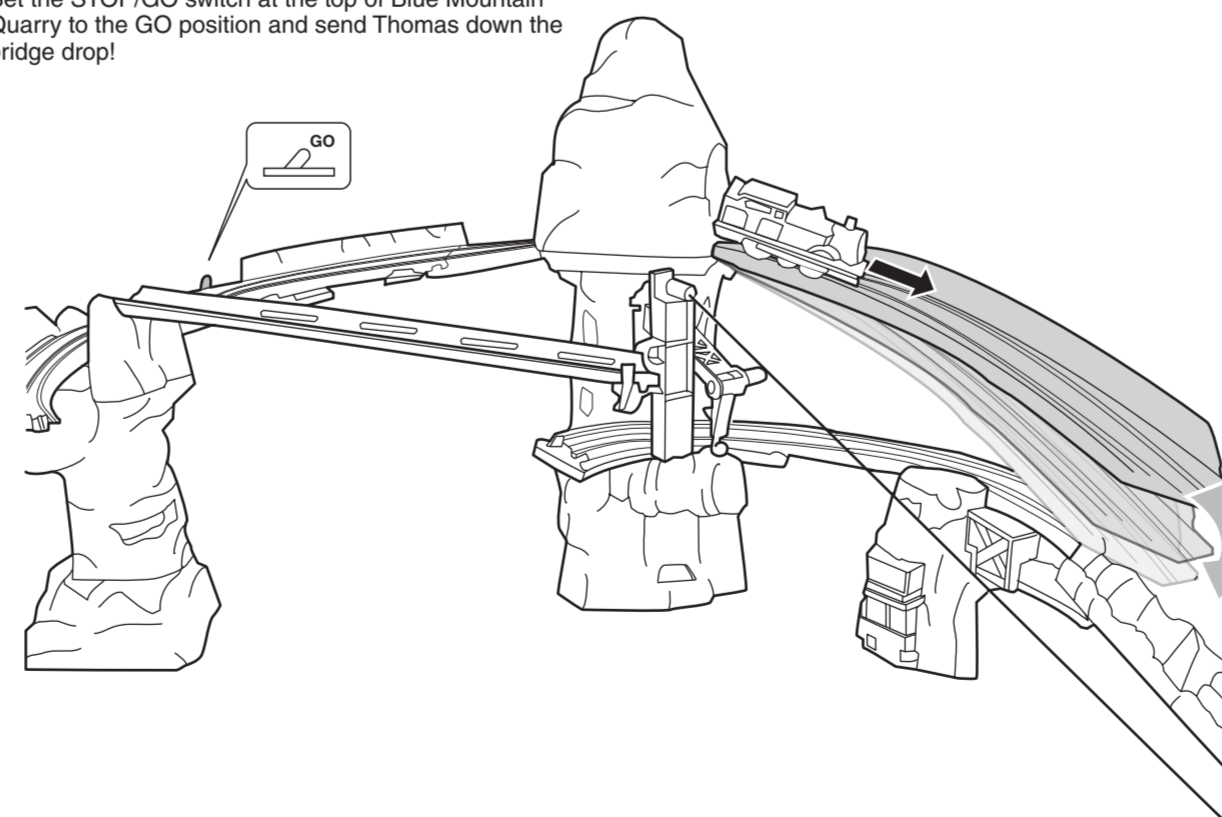

6 Once Thomas arrives at the bottom of the zipline he will stop to pick up the boulder again. Set the STOP/GO switch at the bottom of the zipline to the GO position and send Thomas on his way.

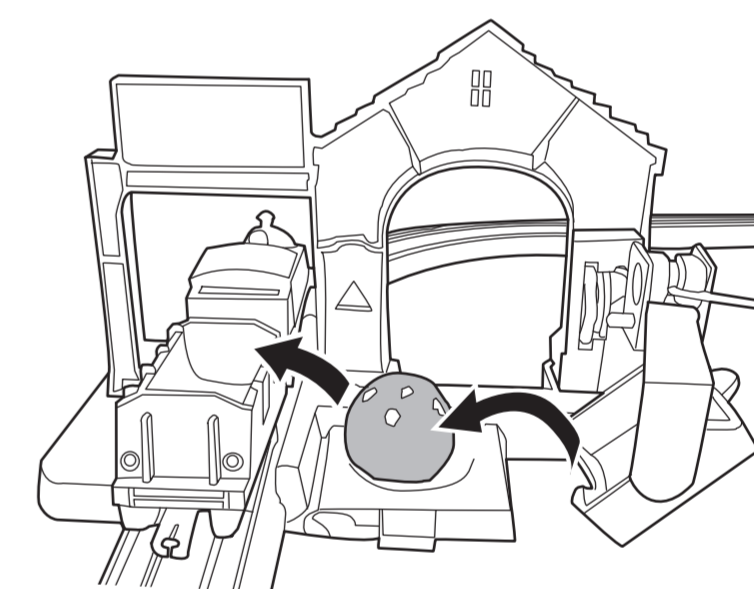

NOTE: MAY NOT WORK WITH ALL ENGINES.

### Part List

A X 1 Double Ended Curve	C X 7 Curve	D X 1 Half Curve	E X 2 Slope Right	F X 1 2 Sided Wall
G X 2 Sloped Straight with Bumps	H X 1 Long Straight with Curve End	I X 1 Curve with Stop Switch	J X 1 Long Hinged Curve	K X 1 Loading Station
L X 3 Track Connector	M X 1 Riser - Low	N X 1 Riser - High	O X 1 Riser - Tunnel	P X 1 2-way Split
Q X 1 Chute	R X 1 Curved Wall			

Instruction page sequence: Side 1

P.5	P.6	COVER
P.2	P.3	P.4

Side 2

Item No : W3542-0920G1  
 Version : EL  
 Size : 24.8" x 11.69"  
 Paper : Woodfree paper 70 gsm  
 Color : Black  
 Date : Feb 29, 2012 (Book)

03/22/2012 Remarks on G1  
 - Update copy

COPY APPROVED