

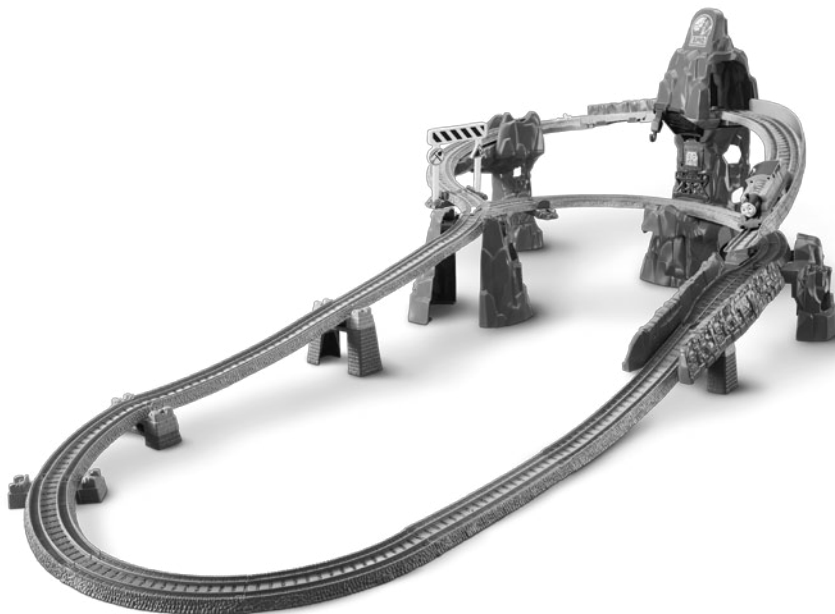

# THOMAS' DARING DROP!

## INSTRUCTIONS

Please keep these instructions for future reference as they contain important information.



### Assembly

#### 1 TOWER 1 (9 pieces)

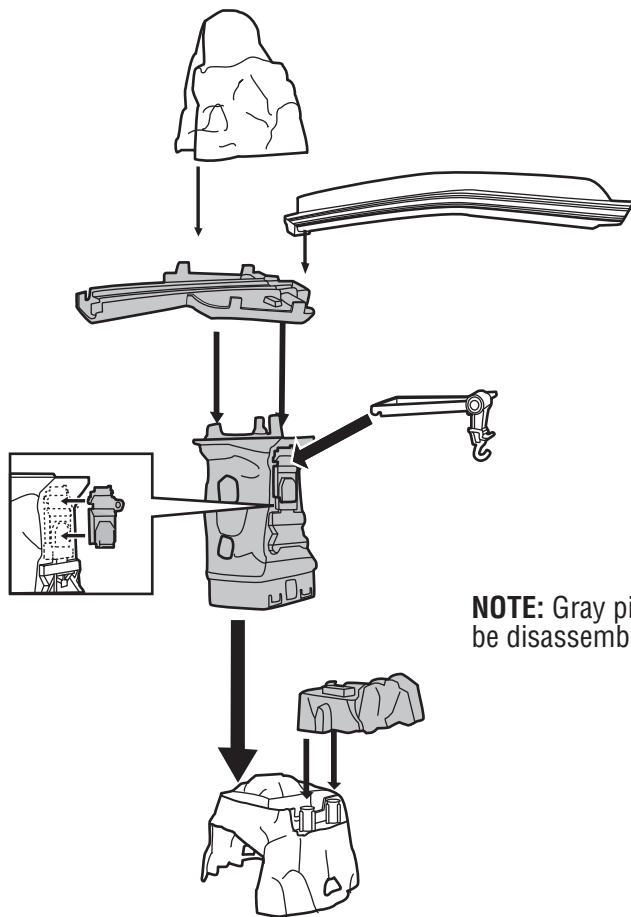

#### 2 TOWER 2 (3 pieces)

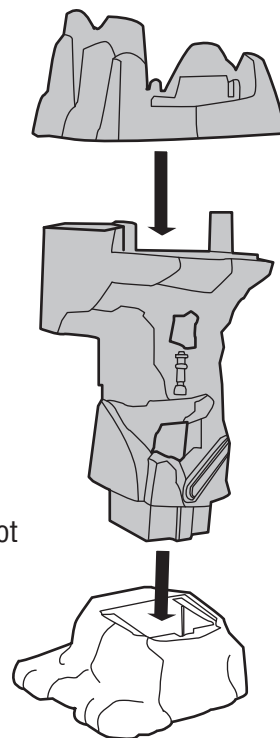

**NOTE:** Gray pieces cannot be disassembled.



**ADULT ASSEMBLY REQUIRED.** No tools required for assembly.

# PART LIST

**A** X 2



Double Ended Curve

**C1** X 7



Curve

**C2** X 1



Half Curve

**D2** X 2



Slope Right

**E** X 1

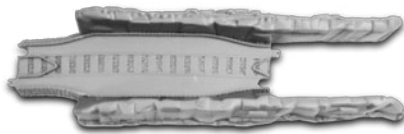

2 Sided Wall

**F** X 2



Sloped Straight with Bumps

**H** X 1



Long Straight with Curve End

**J** X 1



Long Hinged Curve

**P** X 3



Track Connector

**R1** X 1



Riser - Low

**R3** X 1



Riser - High

**R4** X 1

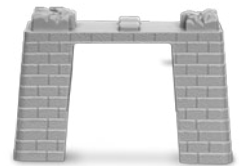

Riser - Tunnel

**S1** X 1



Straight

**Y2** X 1

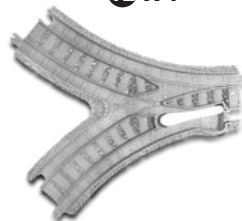

2-way Split



Curved Wall

**NOTE:** Adults should remove & discard rubber bands holding tracks together.

**3 TOWER 3  
(3 pieces)**

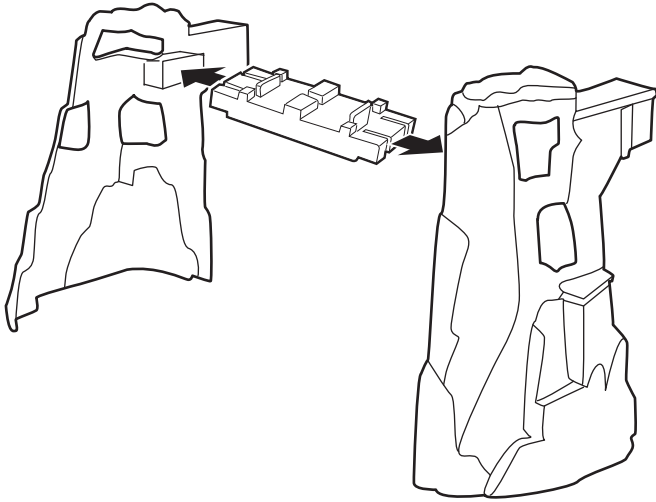

**4 TOWER 4  
(4 pieces)**

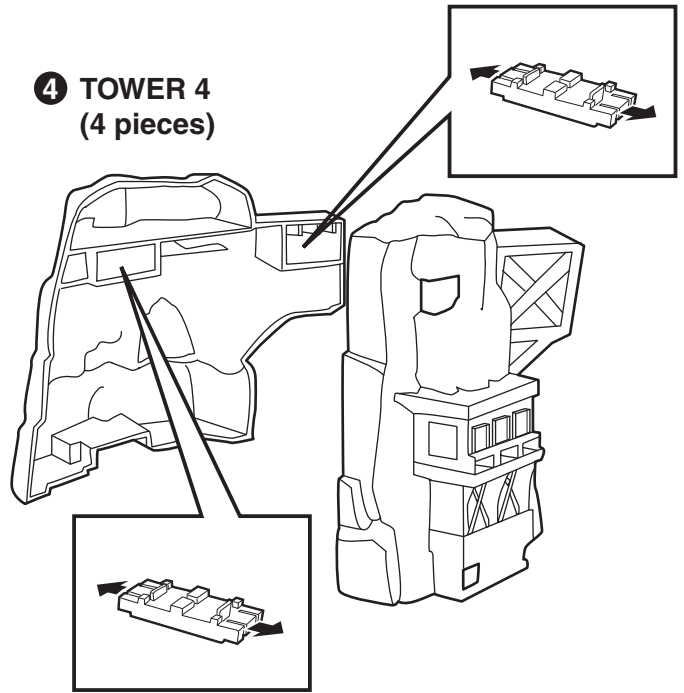

**TRACK LAYOUT**

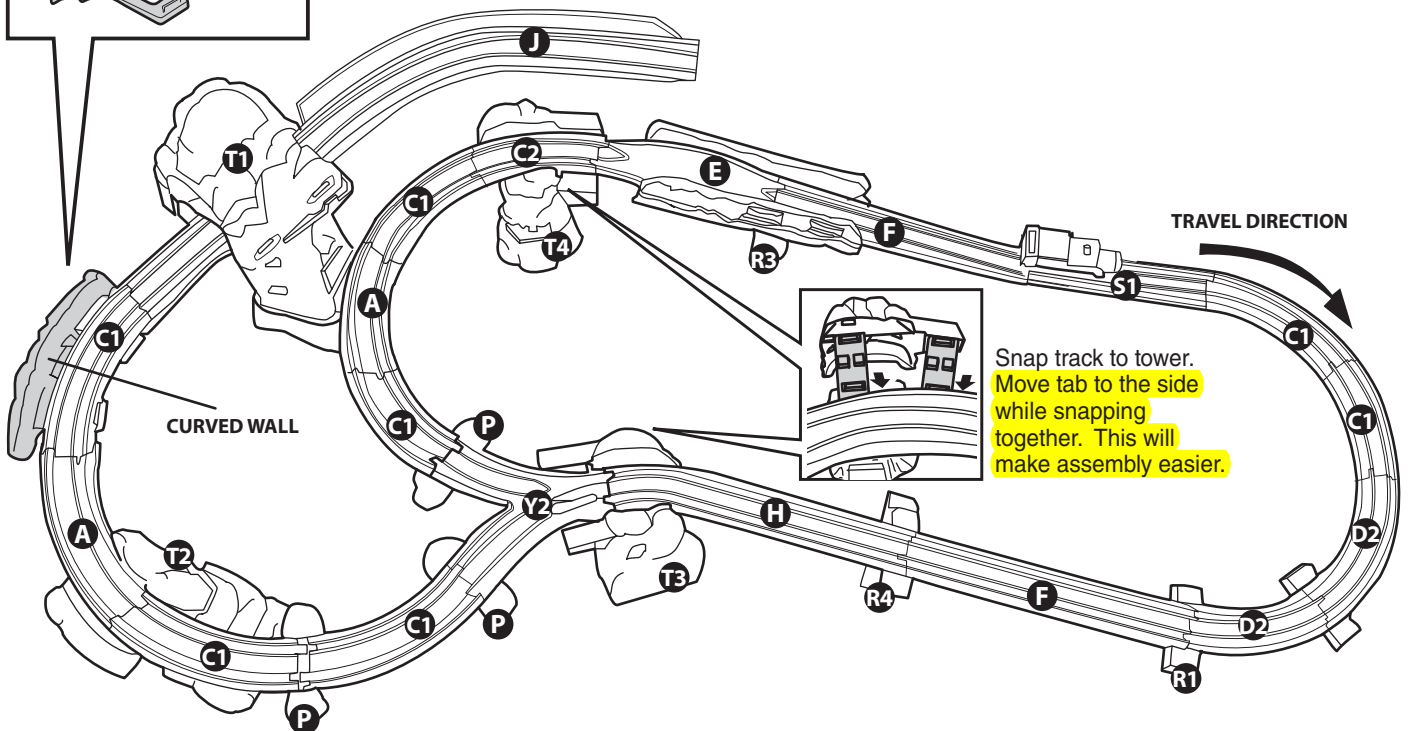
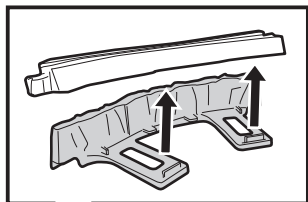

**NOTE: MAY NOT WORK WITH ALL ENGINES.**

## BATTERY INSTALLATION

Unscrew and lift cover away from top of Thomas.  
Install battery as indicated inside the battery compartment.  
For longer life use only alkaline batteries.  
Requires 1 "AA" (LR6) battery.  
If this toy begins to operate erratically, you may need to reset the electronics.  
Remove the batteries from the toy and replace it.

**Thomas**

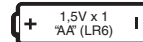

**Required tool:**  
Phillips screwdriver (not included)

## BATTERY SAFETY INFORMATION

In exceptional circumstances batteries may leak fluids that can cause a chemical burn injury or ruin your product. To avoid battery leakage:

- Non-rechargeable batteries are not to be recharged.
- Rechargeable batteries are to be removed from the product before being charged.
- Rechargeable batteries are only to be charged under adult supervision.
- Do not mix alkaline, standard (carbon-zinc), or rechargeable (nickel-cadmium) batteries.
- Do not mix old and new batteries.
- Only batteries of the same or equivalent type as recommended are to be used.
- Batteries are to be inserted with the correct polarity.
- Exhausted batteries are to be removed from the product.
- The supply terminals are not to be short-circuited.
- Dispose of battery(ies) safely.
- Do not dispose of this product in a fire. The batteries inside may explode or leak.

This equipment has been tested and found to comply with the limits for a Class B digital device, pursuant to part 15 of the FCC rules. These limits are designed to provide reasonable protection against harmful interference in a residential installation. This equipment generates, uses and can radiate radio frequency energy and, if not installed and used in accordance with the instructions, may cause harmful interference to radio communications. However, there is no guarantee that interference will not occur in a particular installation. If this equipment does cause harmful interference to radio or television reception, which can be determined by turning the equipment off and on, the user is encouraged to try to correct the interference by one or more of the following measures:

Reorient or relocate the receiving antenna. Increase the separation between the equipment and receiver. Connect the equipment into an outlet on a circuit different from that to which the receiver is connected. Consult the dealer or an experienced radio/TV technician for help.

NOTE: Changes or modifications not expressly approved by the manufacturer responsible for compliance could void the user's authority to operate the equipment.

This device complies with part 15 of the FCC Rules. Operation is subject to the following two conditions:

- (1) This device may not cause harmful interference, and
  - (2) this device must accept any interference received, including interference that may cause undesired operation.
- THIS CLASS B DIGITAL APPARATUS COMPLIES WITH CANADIAN ICES-003.
  - CET APPAREIL NUMERIQUE DE LA CLASSE B EST CONFORME A LA NORME NMB-003 DU CANADA.
  - Operation is subject to the following two conditions: (1) this device may not cause interference, and
  - (2) this device must accept any interference, including interference that may cause undesired operation of the device.
  - L'utilisation de ce produit est sujette aux conditions suivantes : (1) il ne doit pas produire de brouillage et
  - (2) il doit pouvoir tolérer tout brouillage reçu, même si ce brouillage est susceptible de compromettre son fonctionnement.

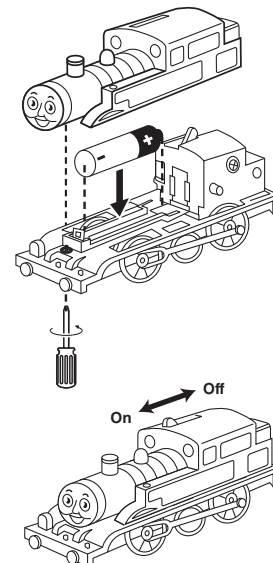

Protect the environment by not disposing of this product with household waste (2002/96/EC). Check your local authority for recycling advice and facilities.



**CAUTION:**

To prevent entanglement, keep hair away from wheels.



## CONSUMER ASSISTANCE

1-800-432-5437 (US & Canada)  
1300 135 312 (Australia)

**service.fisher-price.com**

Fisher-Price, Inc., 636 Girard Avenue, East Aurora, NY 14052.  
Hearing-impaired consumers: 1-800-382-7470.

### Outside the United States:

Canada: Mattel Canada Inc., 6155 Freemont Blvd.,  
Mississauga, Ontario L5R 3W2; [www.service.mattel.com](http://www.service.mattel.com).

Great Britain: Mattel UK Ltd, Vanwall Business Park,  
Maidenhead SL6 4UB. Helpline: 01628 500303.  
[www.service.mattel.com/uk](http://www.service.mattel.com/uk)

Mattel Europa B.V., Gondel 1, 1186MJ Amstelveen, Nederland.

Australia: Mattel Australia Pty. Ltd., 658 Church Street,  
Locked Bag #870, Richmond, Victoria 3121 Australia.

New Zealand: 16-18 William Pickering Drive,  
Albany 1331, Auckland.

Thomas the Tank Engine & Friends™



CREATED BY BRITT ALLCROFT

Based on the Railway Series by The Reverend W Awdry. ©2012 Gullane (Thomas) Limited. Thomas the Tank Engine & Friends and Thomas & Friends are trademarks of Gullane (Thomas) Limited. © HIT Entertainment Limited. HIT and the HIT logo are trademarks of HIT Entertainment Limited.

©2012 Mattel. All Rights Reserved. ® and ™ designate U.S. trademarks of Mattel, except as noted. **PRINTED IN CHINA.** Mattel East Asia Ltd., Room 1106, South Tower, World Finance Centre, Harbour City, Tsimshatsui, HK, China.

**Y1700 / X5346**



**Fisher-Price®**