

# TECH TRAX™

THE ADVANCED CONSTRUCTION SYSTEM FOR ULTIMATE STUNTS



# TECH TRAX™

THE ADVANCED CONSTRUCTION SYSTEM FOR ULTIMATE STUNTS

## AIRSTUNT CHALLENGE™ STUNT SET



• Mattel, Inc., El Segundo, CA 90245 U.S.A. Consumer Affairs 1 (800) 524-TOYS.  
• Mattel U.K. Ltd., Vanwall Business Park, Maidenhead SL6 4UB. Helpline: 01628500303.  
• Mattel Australia Pty., Ltd., Richmond, Victoria. 3121. Consumer Advisory Service - 1300 135 312.  
• Mattel East Asia Ltd., Room 1106, South Tower, World Finance Centre, Harbour City, Tsimshatsui, HK, China.  
• Diimport & Diedarkan Oleh: Mattel SEA Ptd Ltd. (993532-P) Lot 13.5, 13th Floor, Menara Lien Hoe, Persiaran Tropicana Golf Country Resort, 47410 PJ. Tel:03-78803817, Fax:03-78803867.



Cool cars, games and more!

8+

B4688-0920



### INSTRUCTIONS

© 2004 Mattel, Inc. All Rights Reserved.



# PARTS

(1) 3D Base (2) Long Leg (1) Diverter (1) Flip Jumper (1) Booster (2) Aux Base (1) T2P (Adaptor for connecting to other tracks)

(7) 90° Joint (2) Short Leg (7) 3XL (1) Booster Riser (1) Landing Pad Support (1) Landing Pad

(1) Small Support (1) Label Sheet (1) 45° Joint (2) 24.5" (62 cm) Guardrails (2) 40" (101.6 cm) Guardrails (2) 67" (170 cm) Guardrails (2) 83" (210.8 cm) Guardrails (1) Coupler (1) Airstunt Pump (10) U-Clips (144) Black Clips

(1) VJ/C Mechanism (12) Guardrail Connectors

(2) R-4 (4) R-6 (6) R-9 (5) R-12 (2) R-18

(1) Car Jump Master™ (11) C-3 (2) C-2 (3) C-1 (2) S-9 (1) S-12 (3) S-18

# TECH TRAX™ BUILDING BASICS

All track connections lock together with the **TECH TRAX™** system. Be sure tabs insert fully to lock tracks together properly as shown.

Clips attach to tracks as shown. Notches on clips align with tabs on tracks to lock in proper position.

Press guardrails into clips until they snap and lock.

Extend Guardrails with Guardrail Connector

End of Guardrail

Snap!

Rod marking system.

Track marking system.

Push air tubes onto connections fully to prevent any air leaks.

UNLOCK LOCK CONNECTOR



# INSTALL BATTERIES

## BATTERY PACK

BATTERIES NOT INCLUDED.  
PHILLIPS HEAD SCREWDRIVER NOT INCLUDED.

3 "D" cell batteries required.  
For longer life, use only alkaline batteries.

Replace batteries when booster can no longer  
propel cars through the track set.

Parts required:

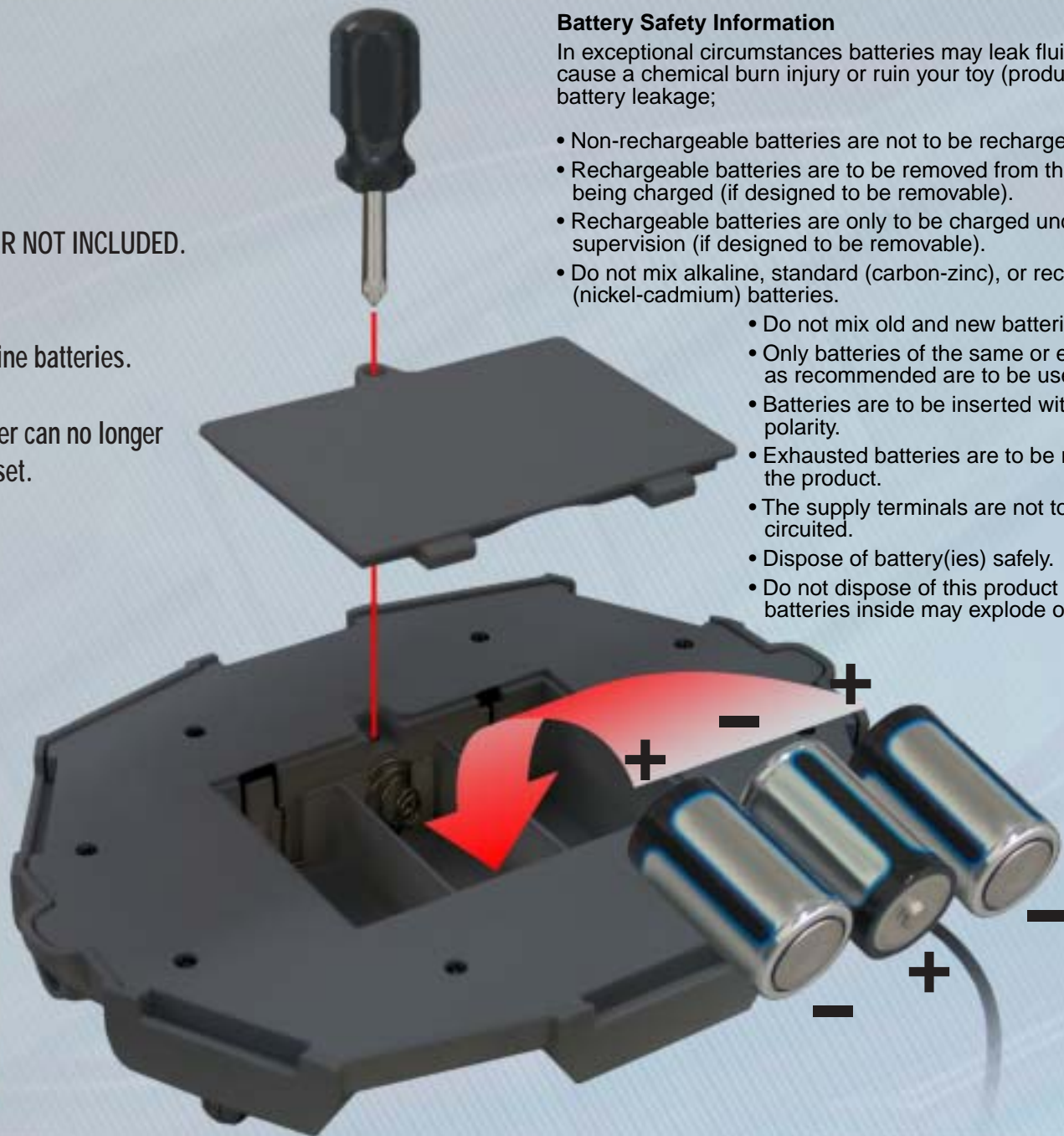

### Battery Safety Information

In exceptional circumstances batteries may leak fluids that can cause a chemical burn injury or ruin your toy (product). To avoid battery leakage;

- Non-rechargeable batteries are not to be recharged.
- Rechargeable batteries are to be removed from the product before being charged (if designed to be removable).
- Rechargeable batteries are only to be charged under adult supervision (if designed to be removable).
- Do not mix alkaline, standard (carbon-zinc), or rechargeable (nickel-cadmium) batteries.
  - Do not mix old and new batteries.
  - Only batteries of the same or equivalent type as recommended are to be used.
  - Batteries are to be inserted with the correct polarity.
  - Exhausted batteries are to be removed from the product.
  - The supply terminals are not to be short-circuited.
  - Dispose of battery(ies) safely.
  - Do not dispose of this product in a fire. The batteries inside may explode or leak.

# 1

# START ASSEMBLING

## Base support

Apply labels 1, 2 and 3.

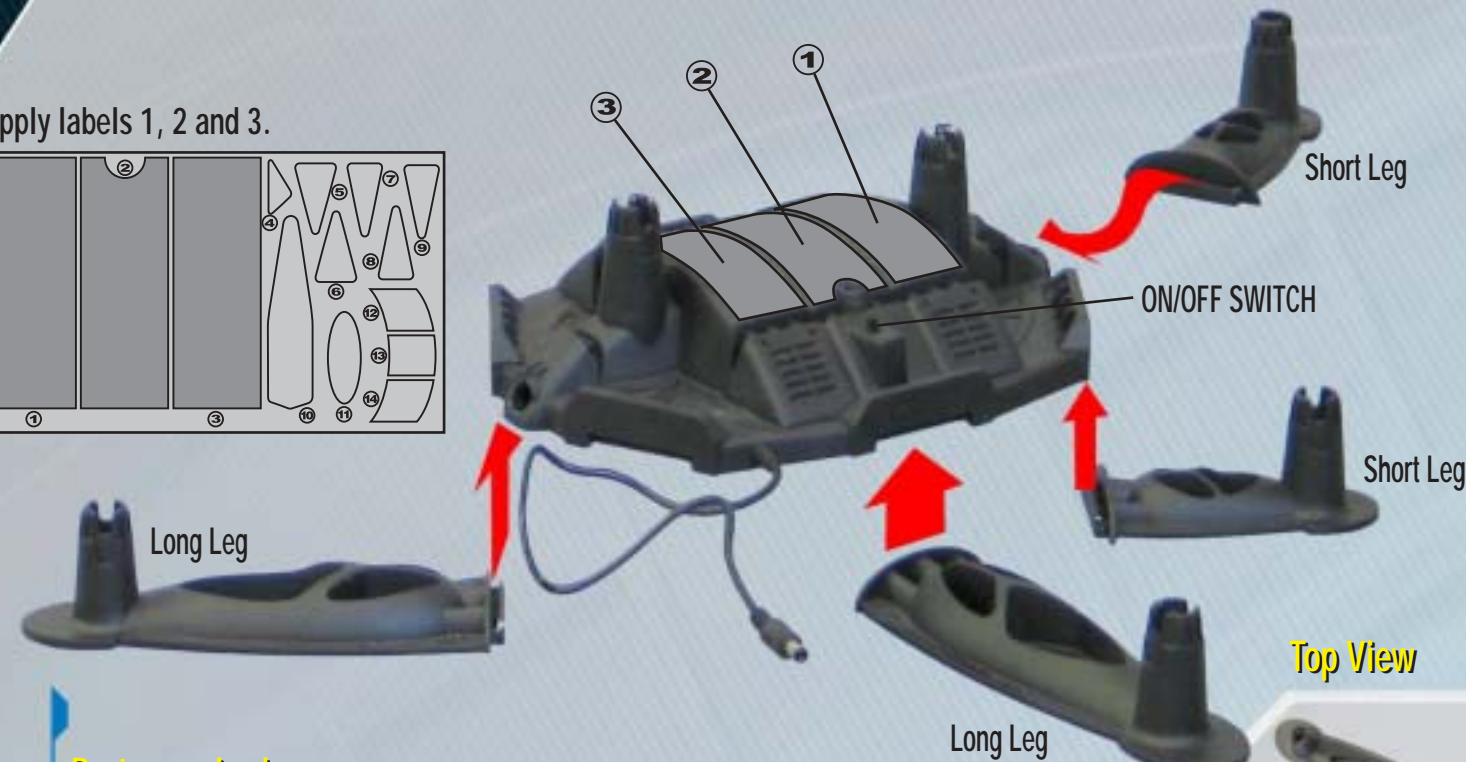
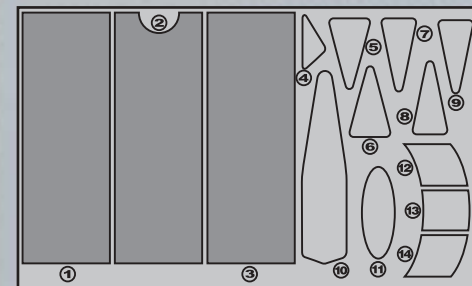

Parts required:



Top View

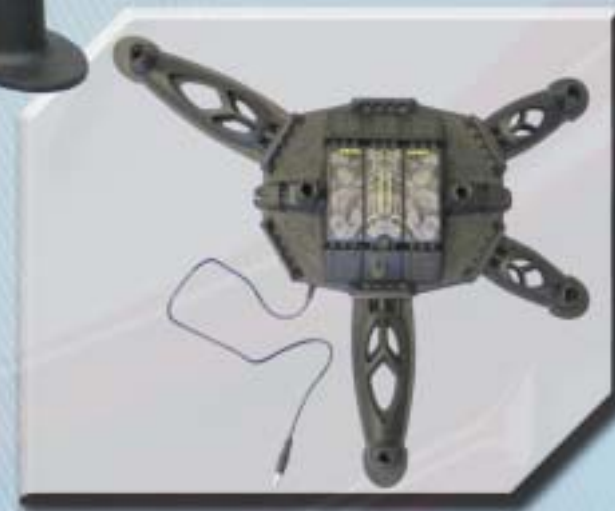



2

Top View

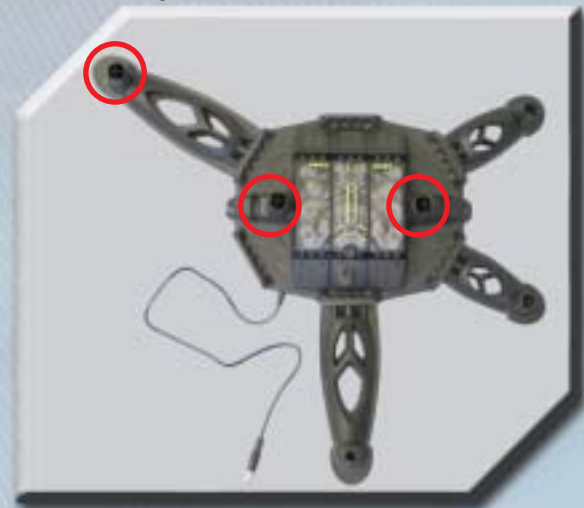

Parts required:

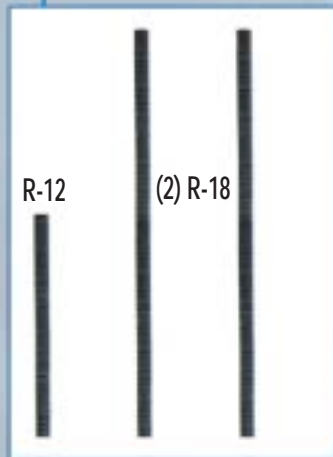

3

Top View

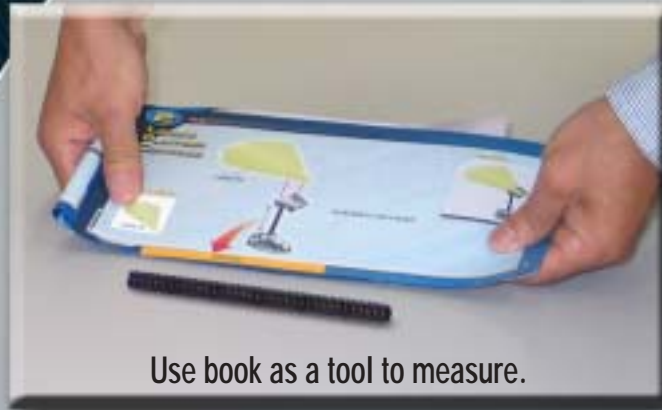

Use book as a tool to measure.

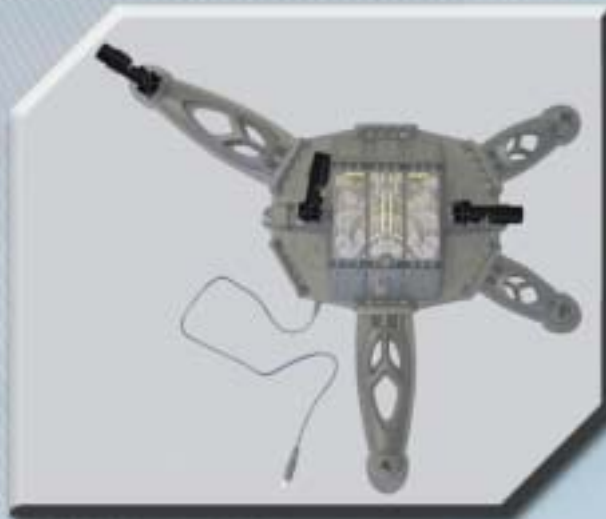
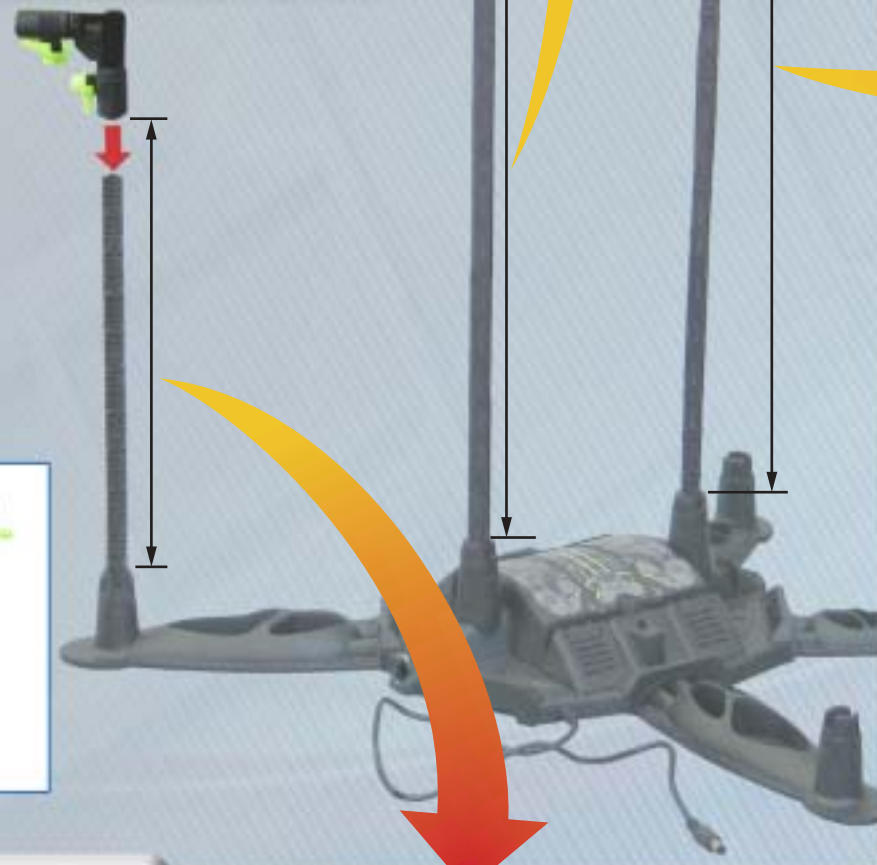

Parts required:



Connected



1" (2.5 cm)

8.625" (21.9 cm)



-10.375" (26.4 cm)

4

Top View

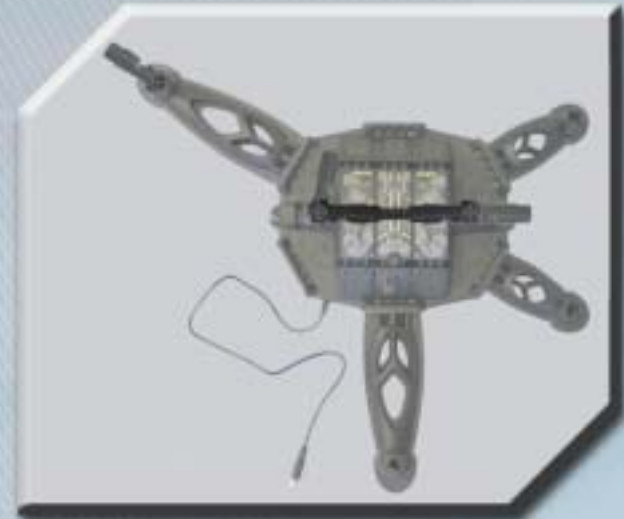

Connected



Parts required:



5

8.5" (21.6 cm)

Parts required:

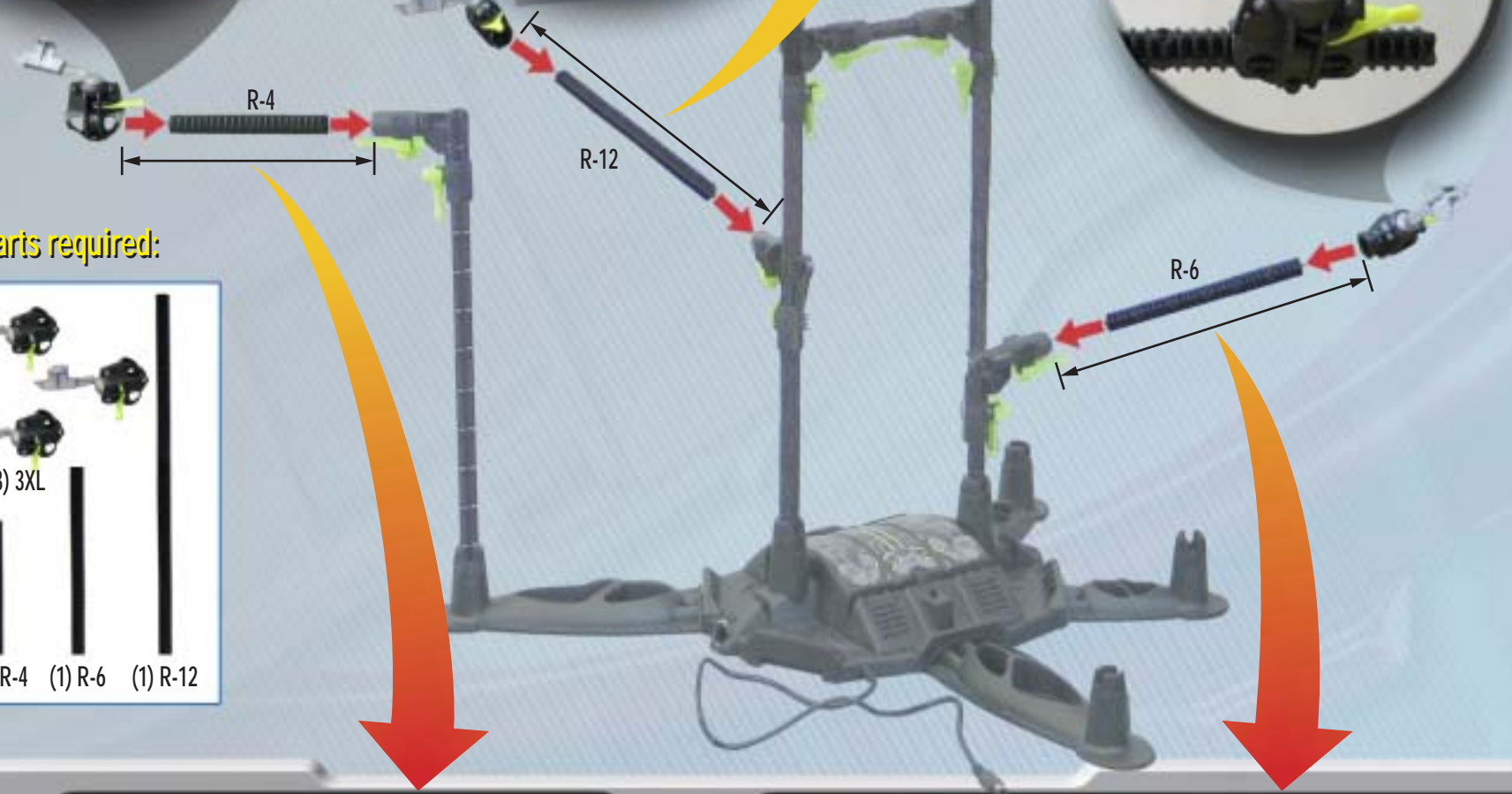

.75" (1.9 cm)

2" (5.1 cm)



6



Parts required:

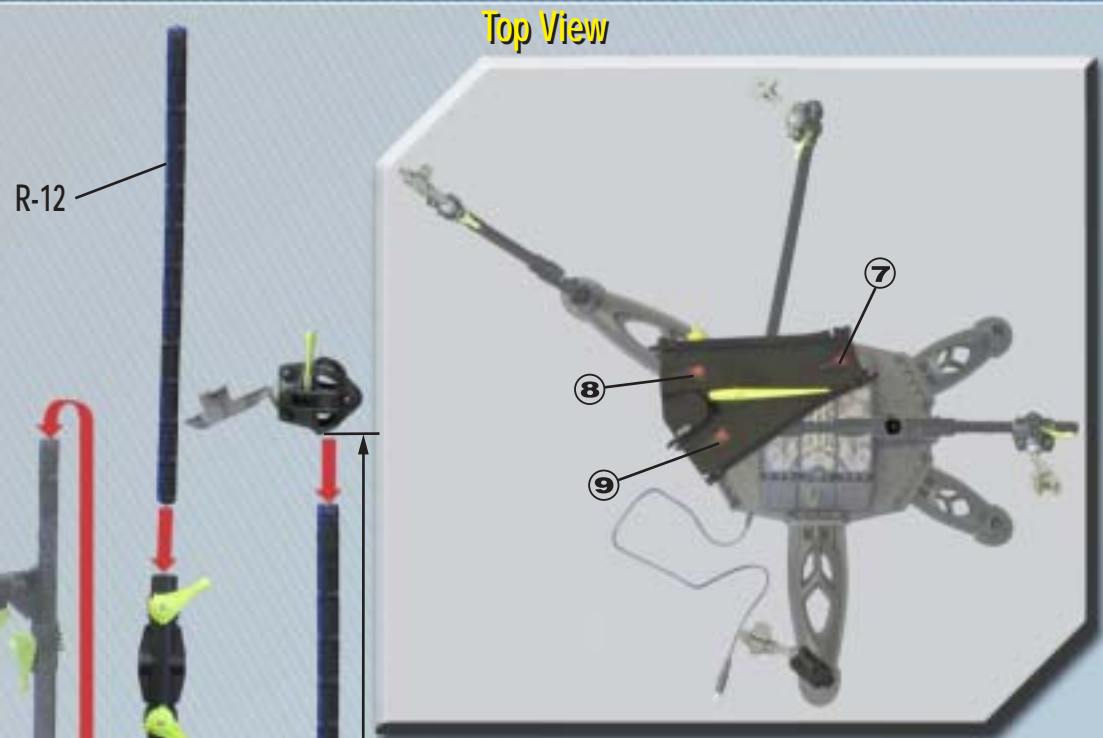

Apply labels 7, 8 and 9.

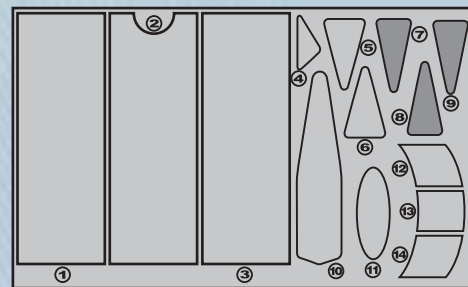

7.5" (19 cm)

7



Parts required:



2.125" (5.4 cm)

.875" (2.2 cm)

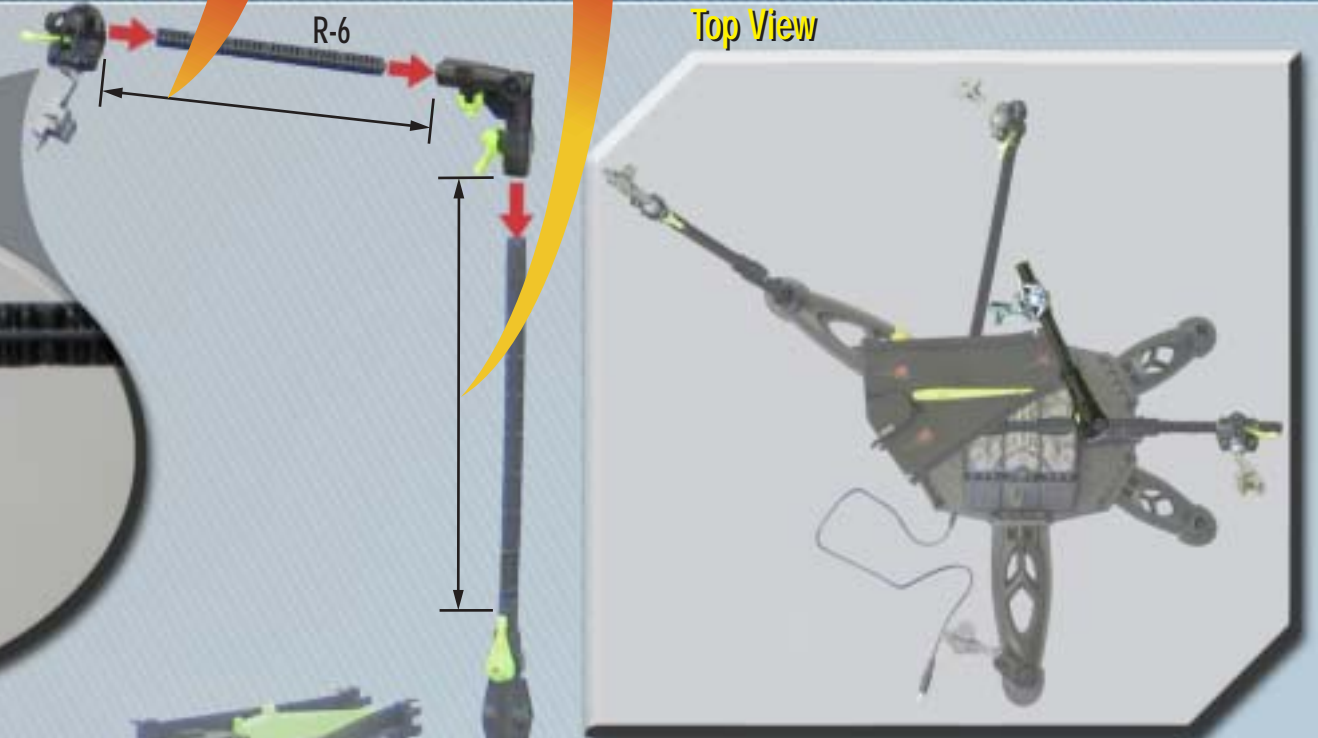



5.75" (14.6 cm)

8

0.5" (1.3 cm)

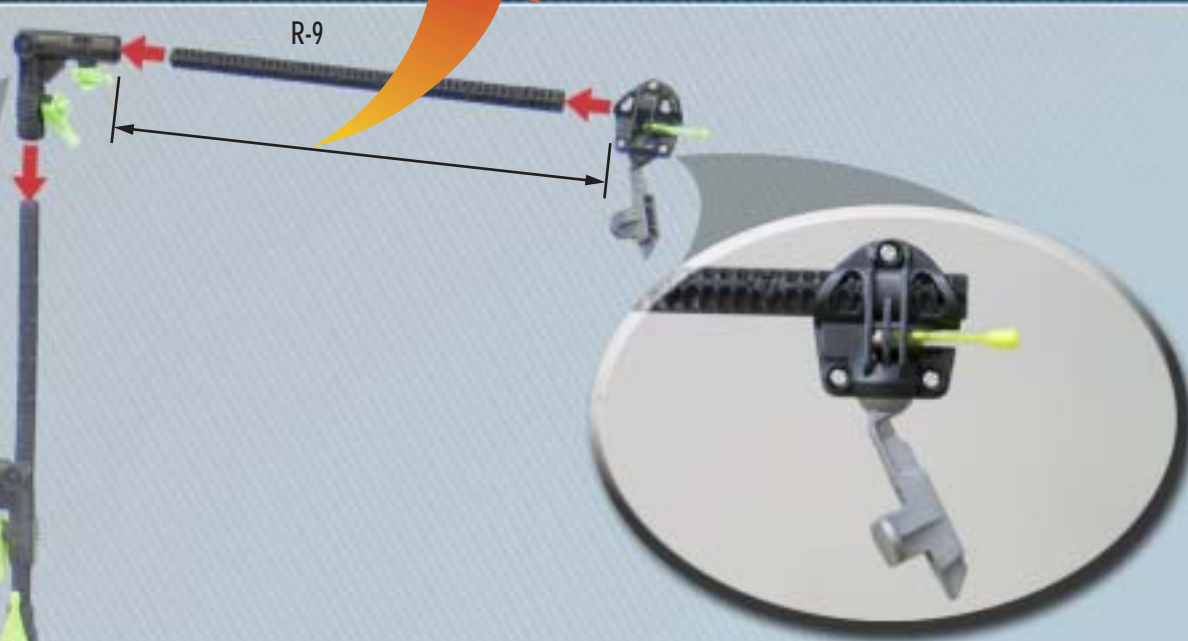

Parts required:



2.375" (6 cm)

9

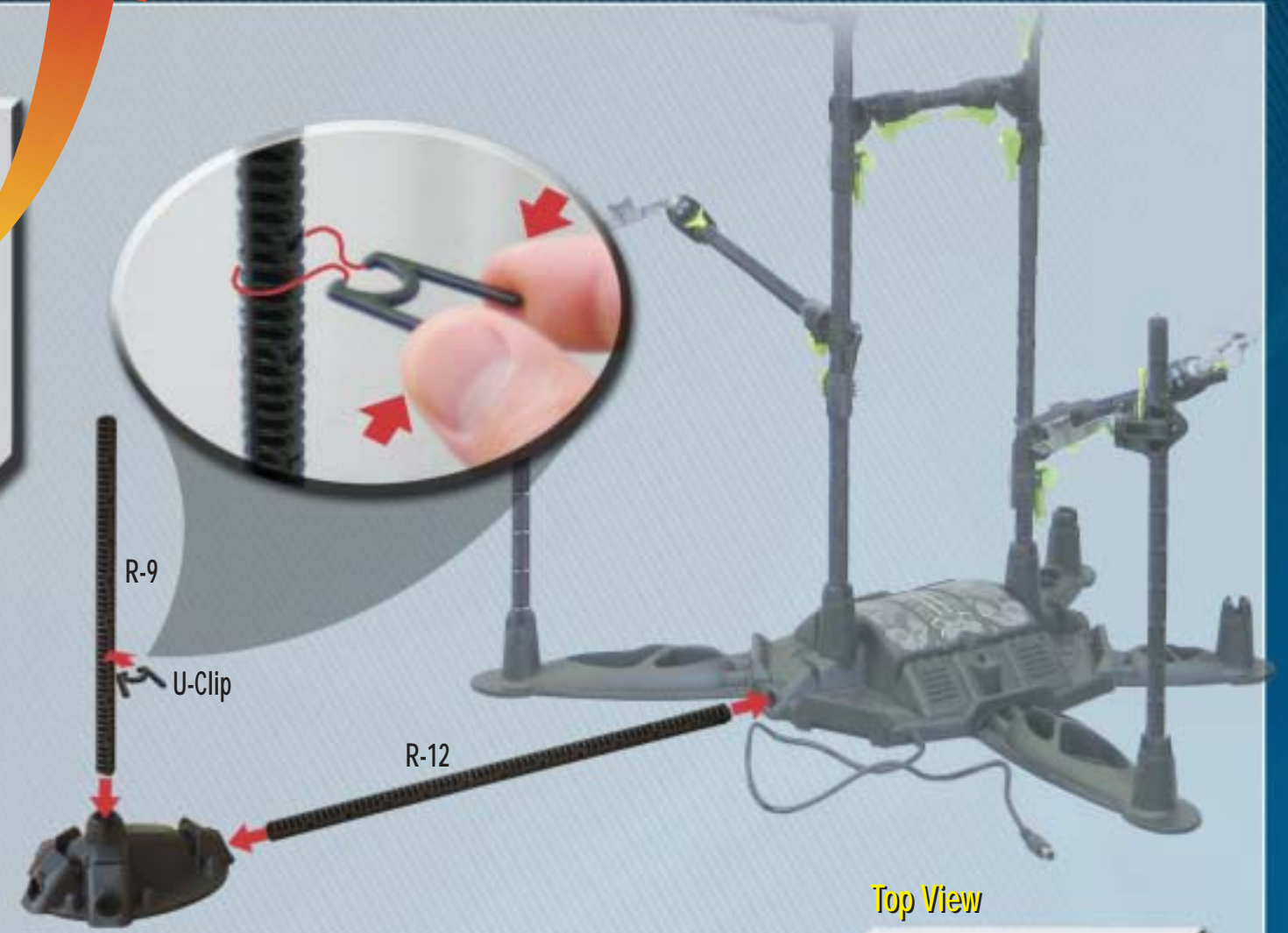

Parts required:



Top View





10

Apply label 10.

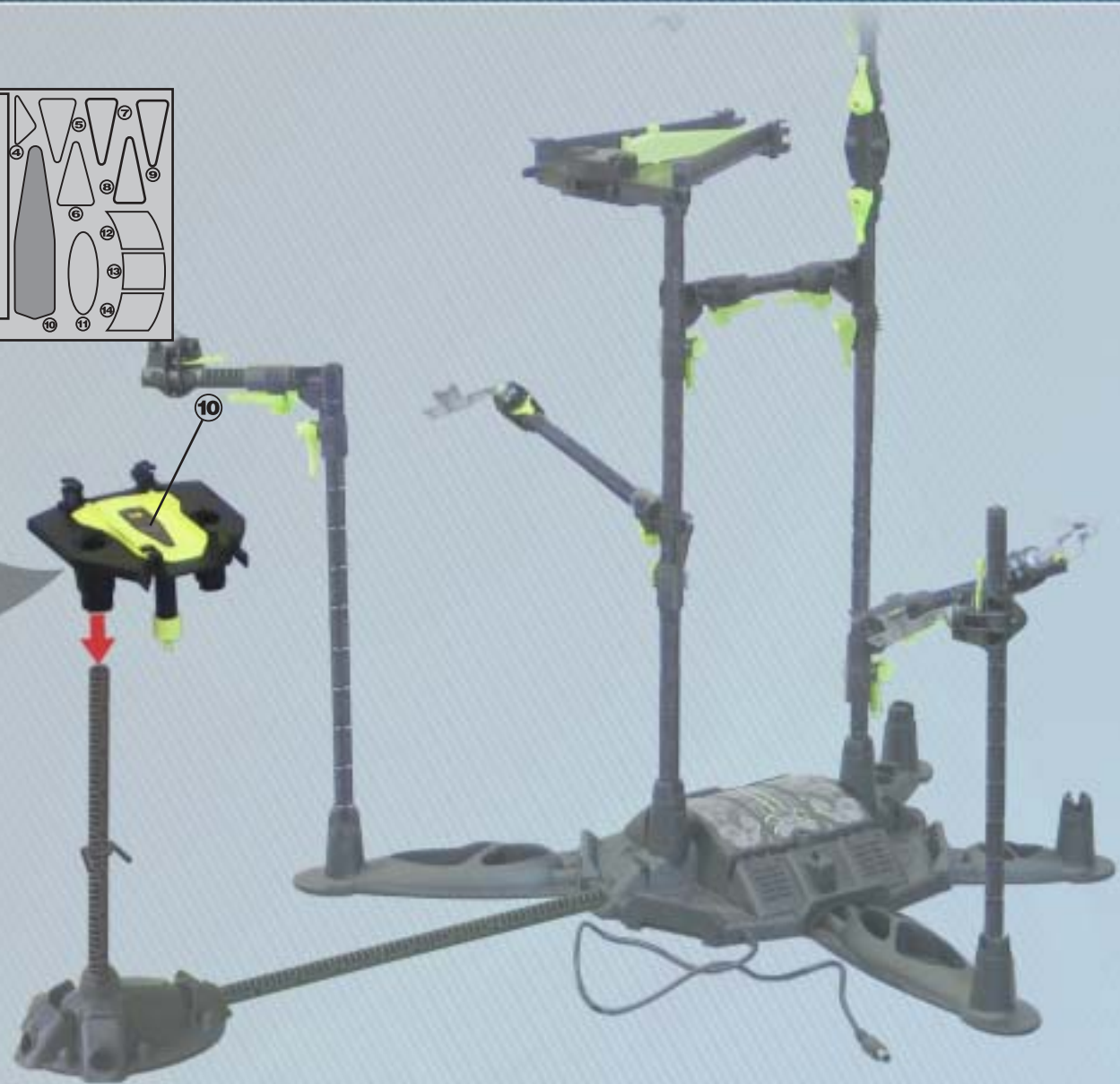
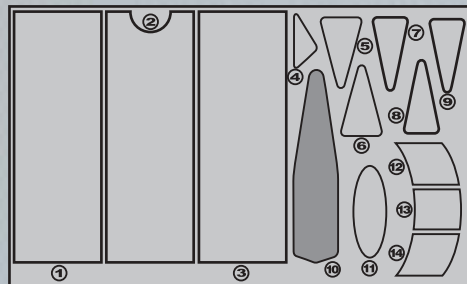

Parts required:



11

2.5" (6.4 cm)



Parts required:





12



Top View

Parts required:

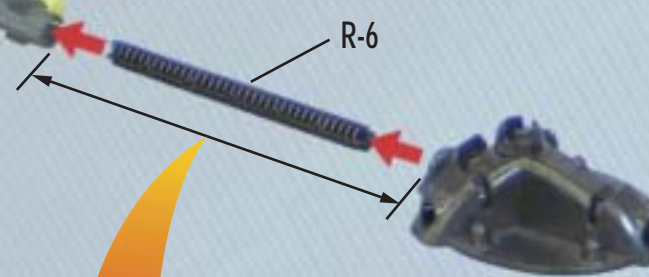

3.375" (8.6 cm)

13

# CONNECT LANDING

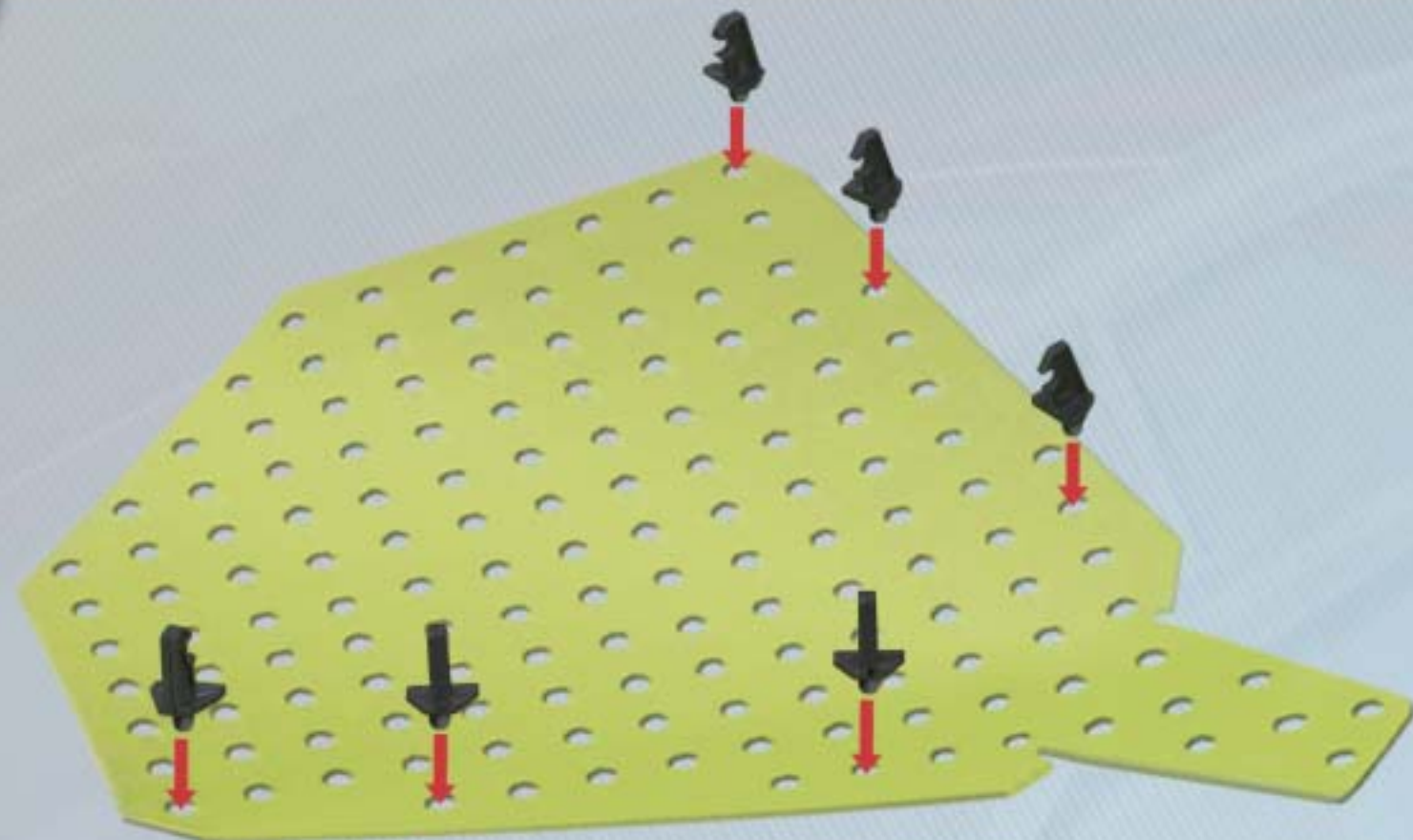

See detail on page 17.

Connected

Parts required:





14

# LANDING PAD CLIP LOCATIONS

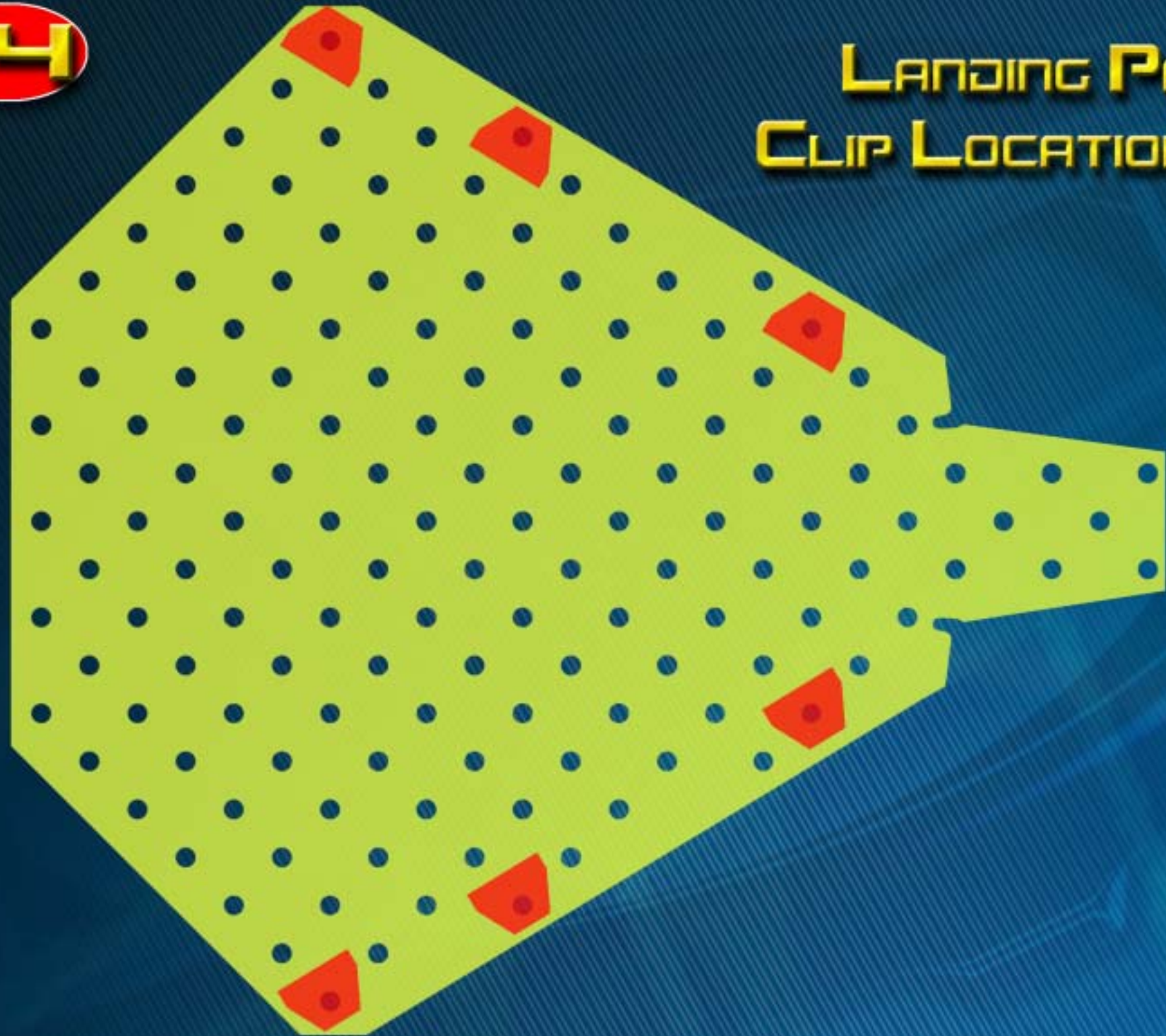

15

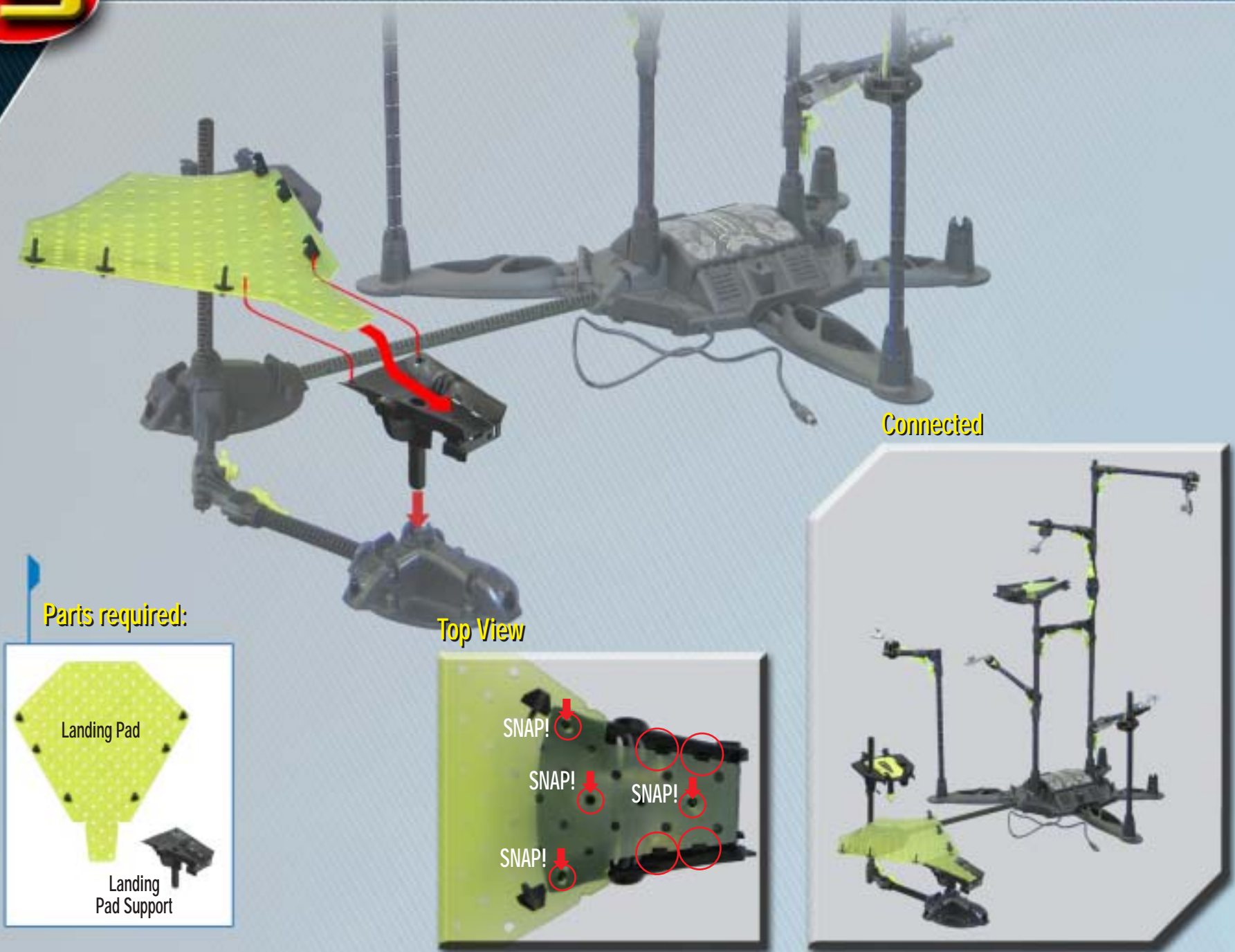



16

# PHASE 1 TRACK ASSEMBLY

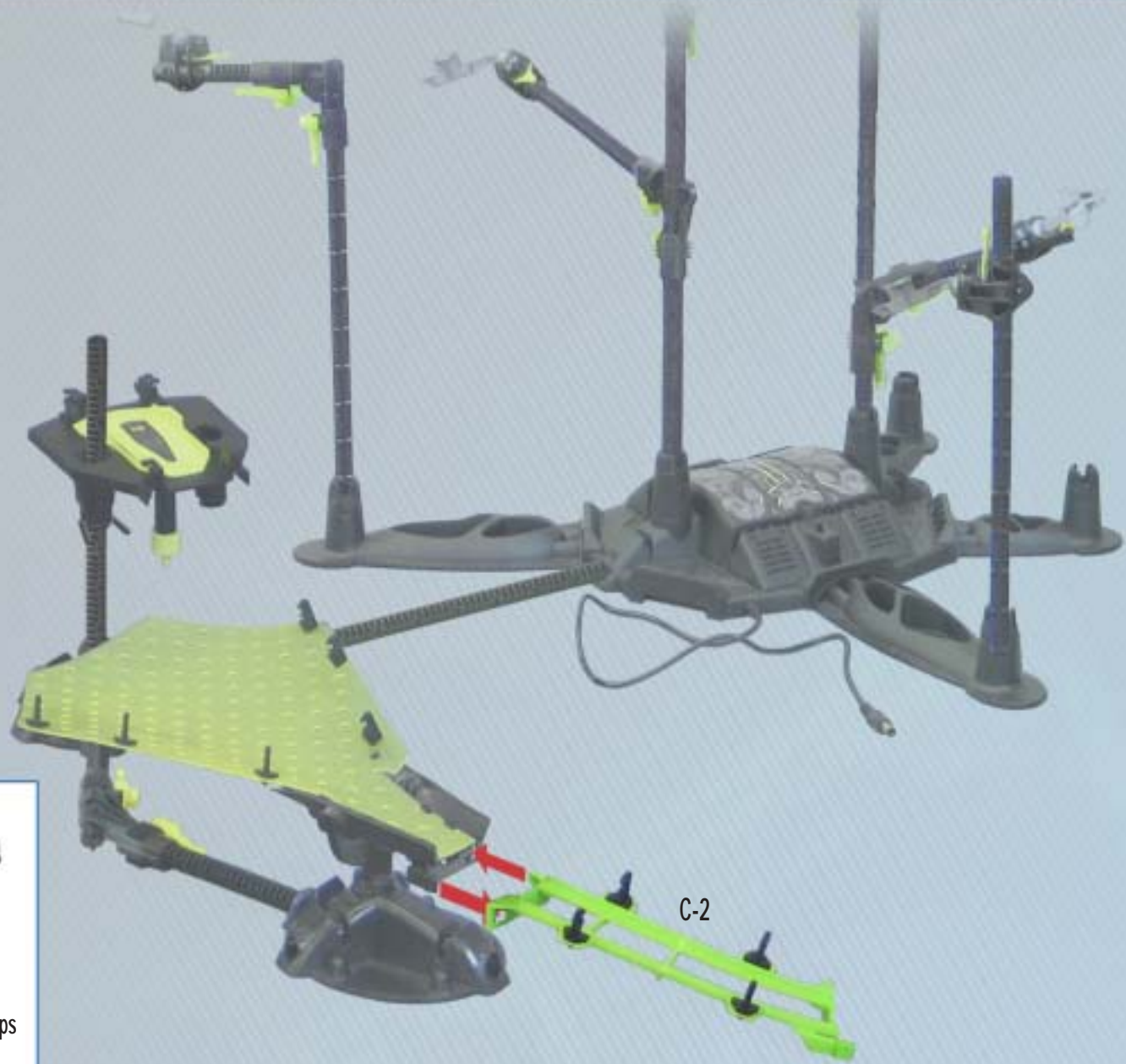

Parts required:

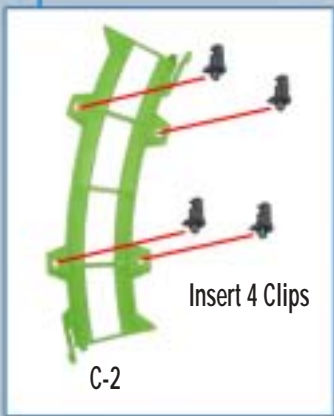

17



Parts required:

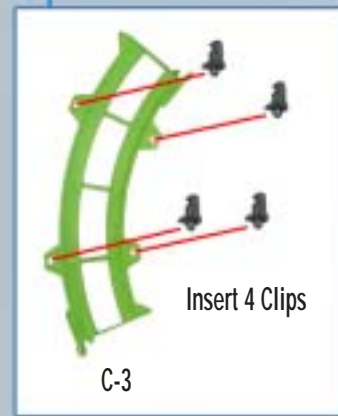



18

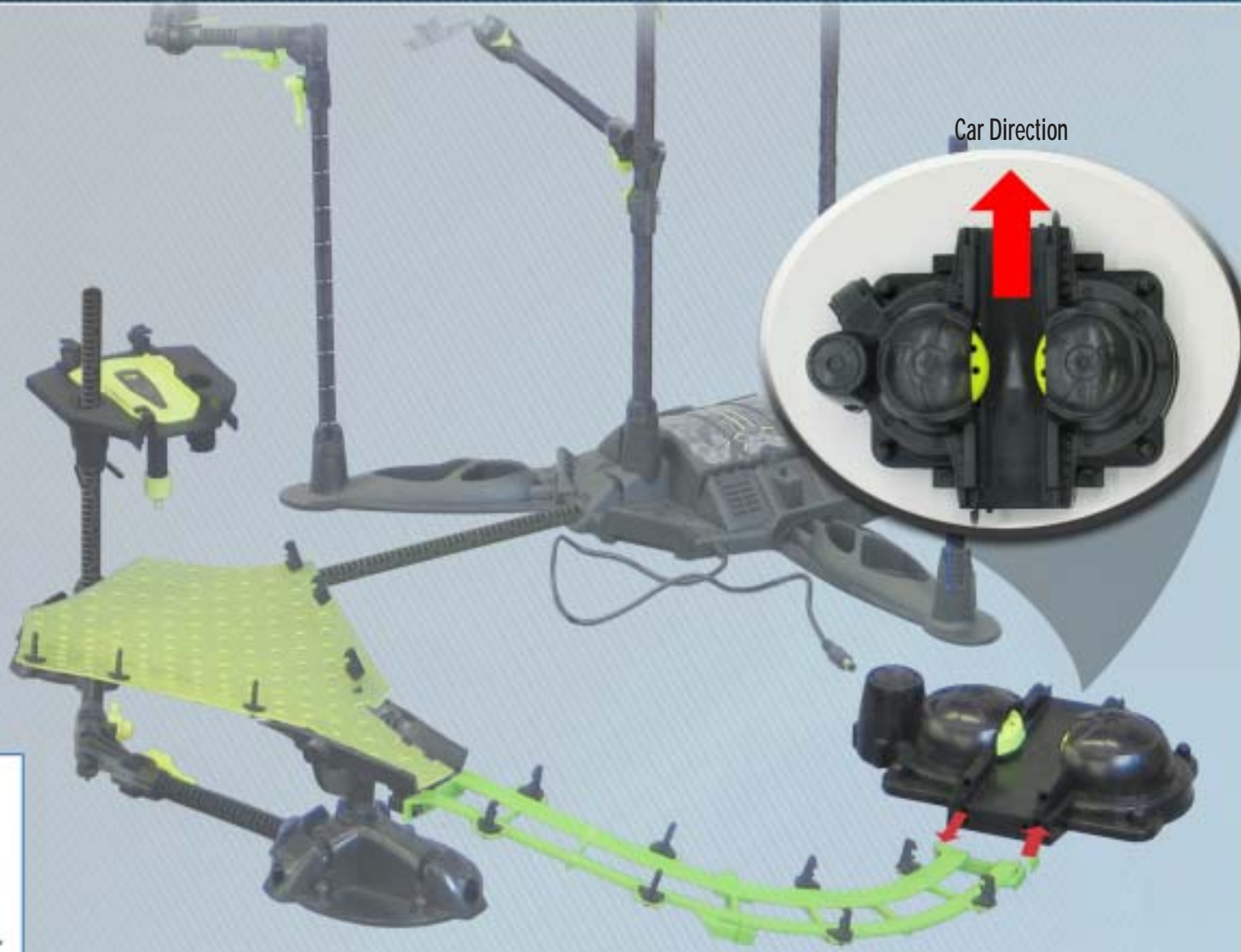

Parts required:



Booster

19

# PHASE 1 TRACK GUARDRAILS

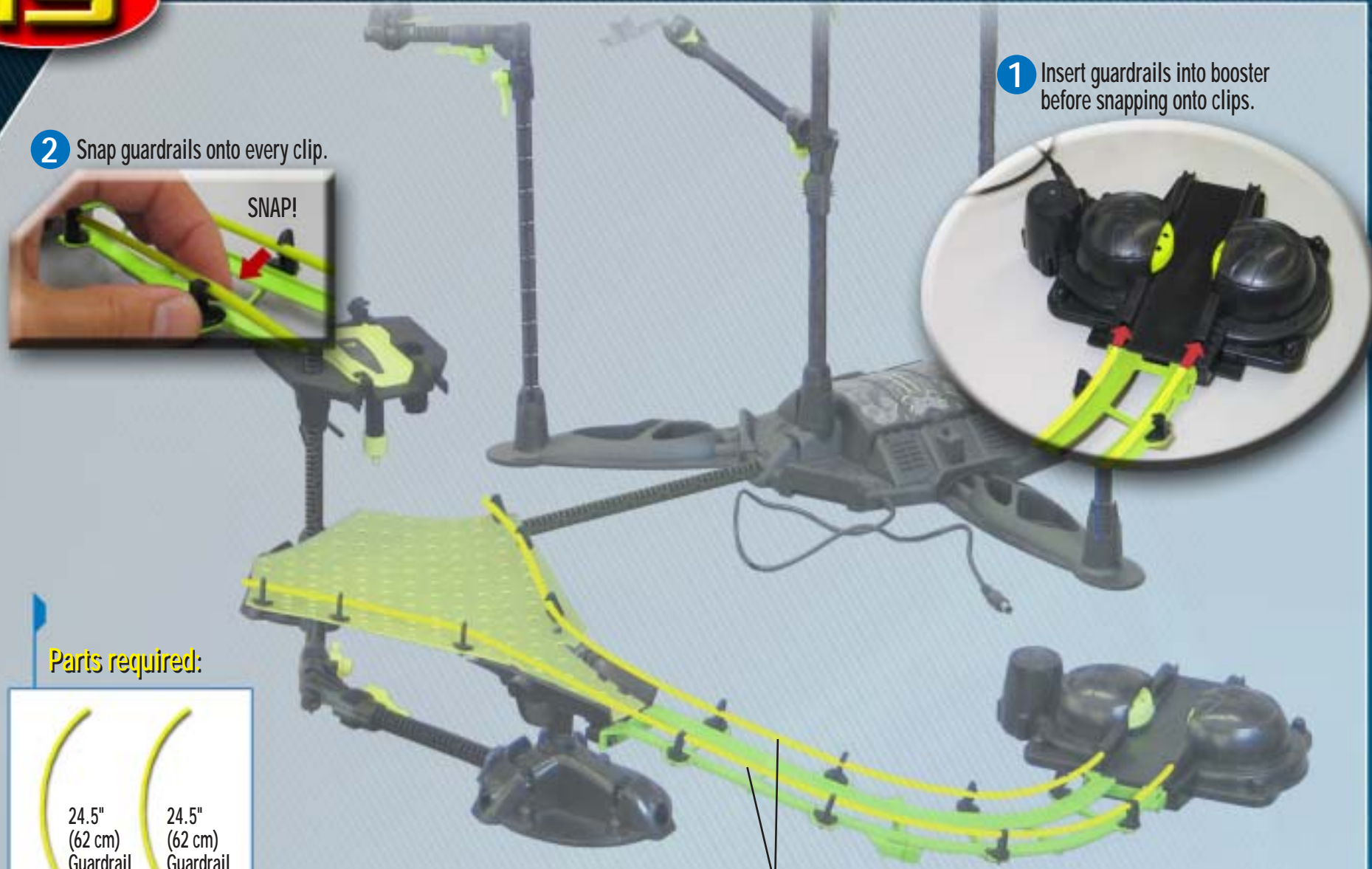

2 Snap guardrails onto every clip.

1 Insert guardrails into booster before snapping onto clips.

Parts required:



24.5" (62 cm) Guardrail

24.5" (62 cm) Guardrail

24.5" (62 cm) Guardrail



# 20

## PHASE 2 TRACK ASSEMBLY



Parts required:

(3) S-18	(1) S-12	(2) C-1

Insert 56 Clips

# 21

## PHASE 2 TRACK INSTALLATION FLOW

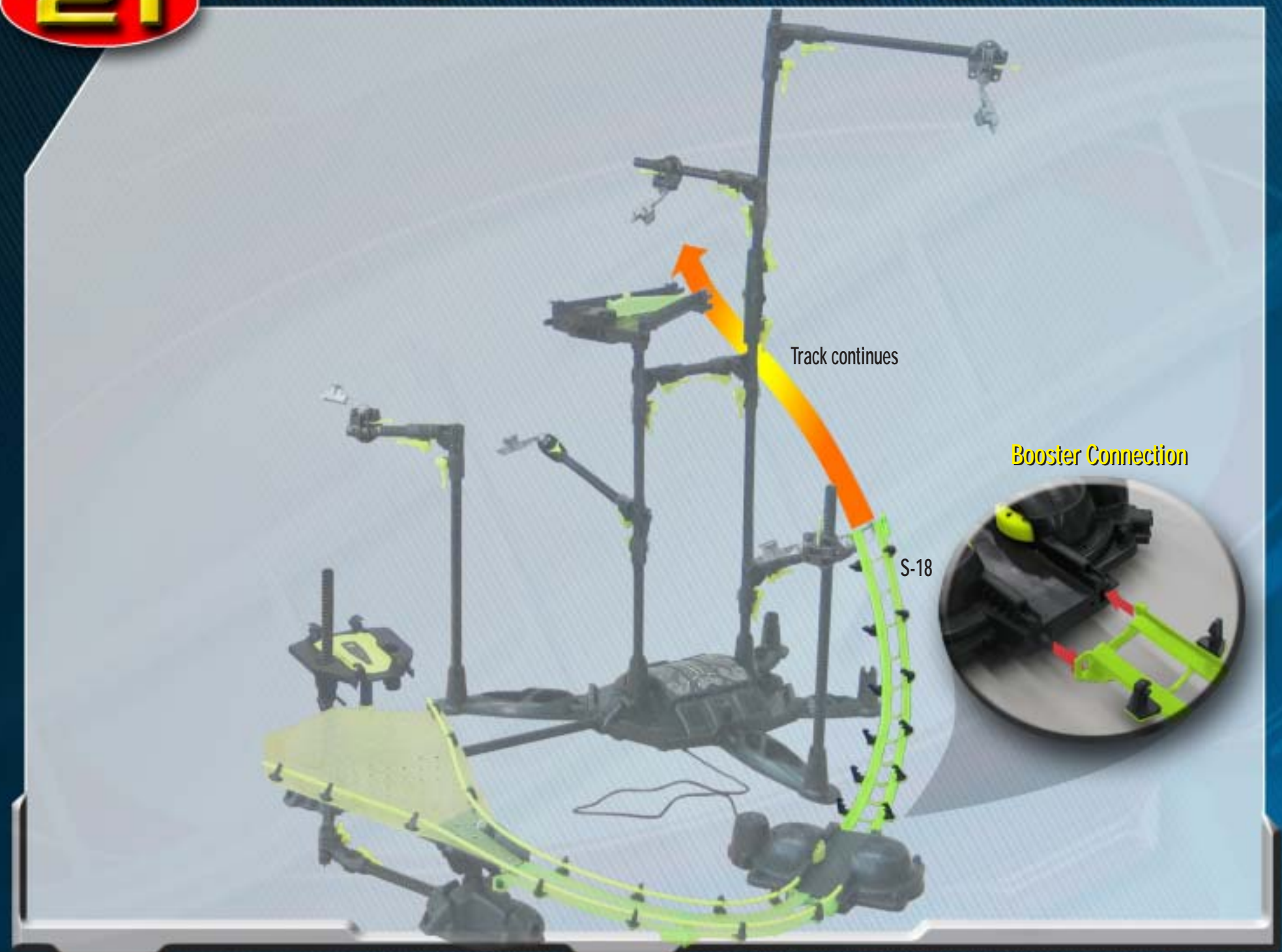



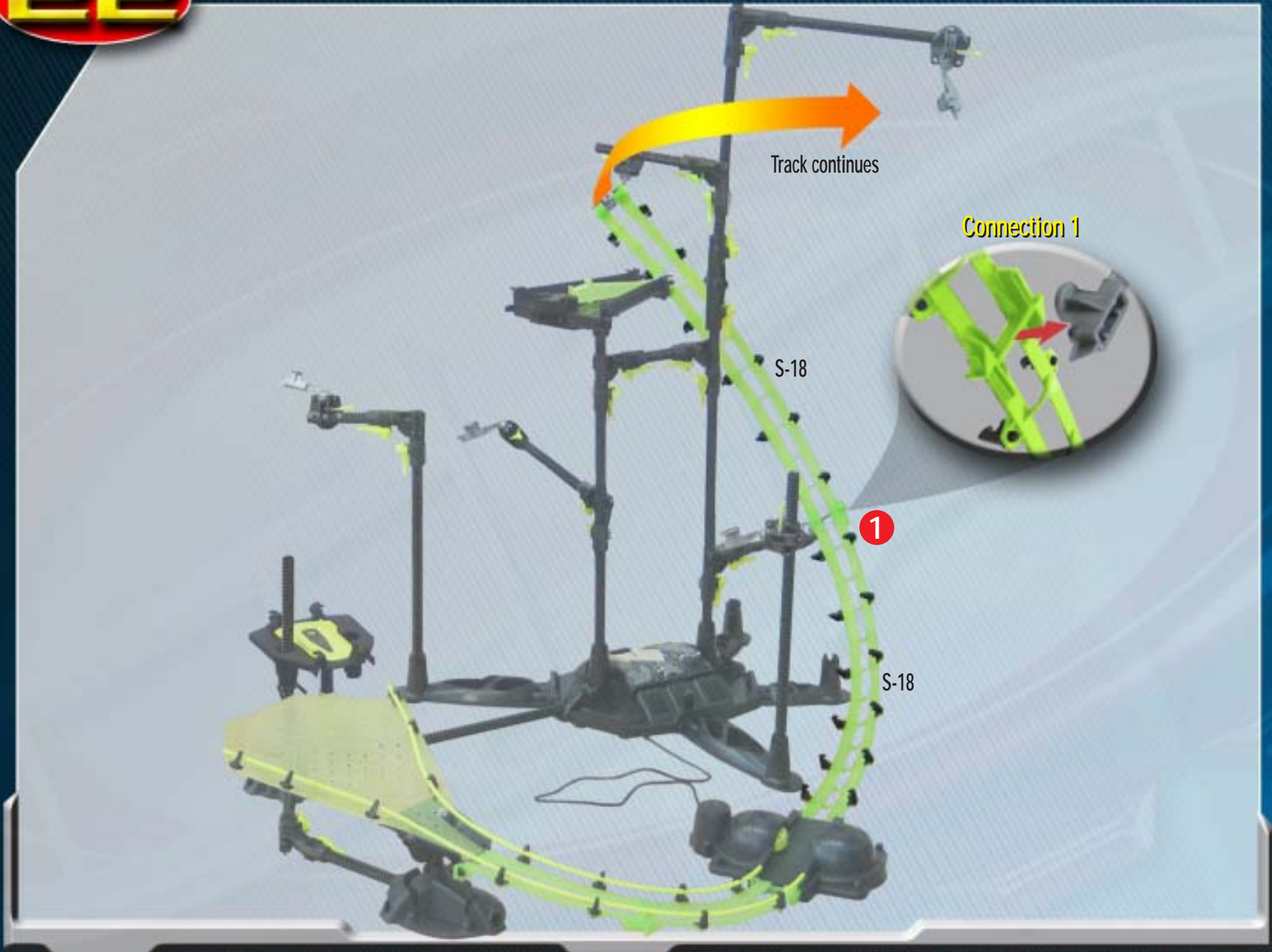



24



25





26



Diverter Connection

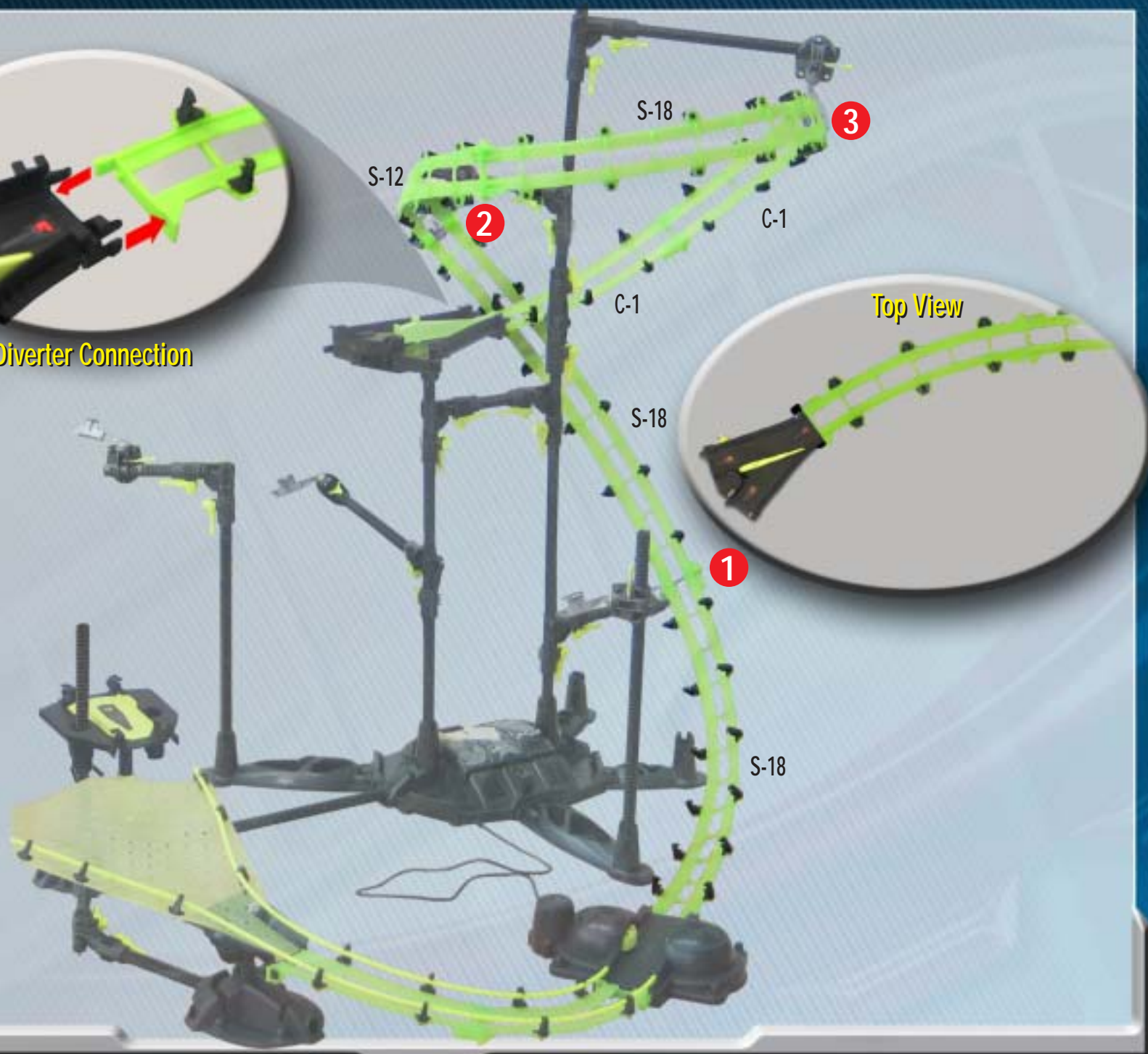

27

# PHASE 2 TRACK GUARDRAILS



3 Snap guardrails onto Diverter.

2 Snap guardrails onto every clip.



83" (210.8 cm) Guardrails

Parts required:



(2) 83" (210.8 cm) Guardrails

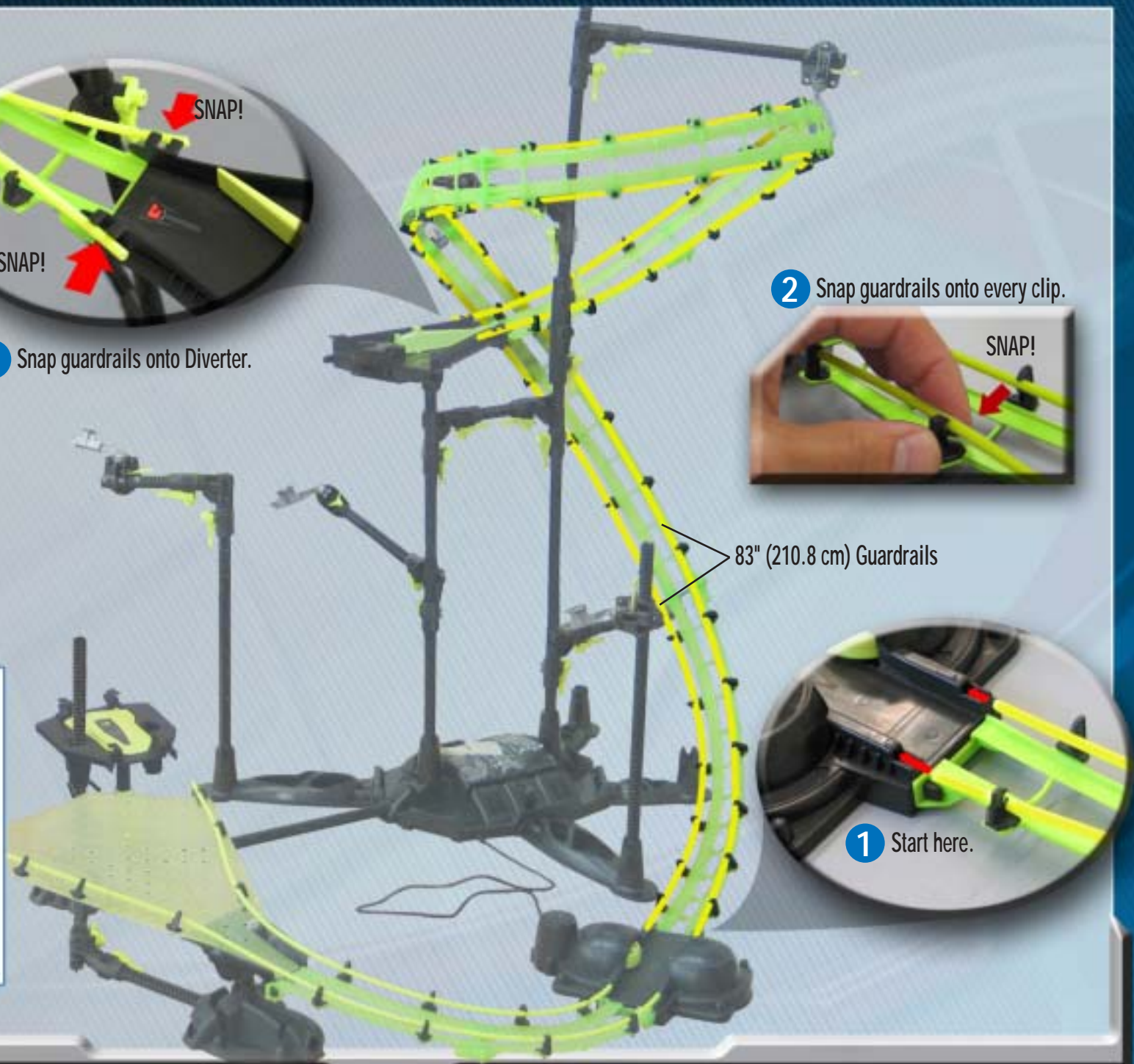

1 Start here.



28

# PHASE 3 TRACK ASSEMBLY



29

# PHASE 3 TRACK INSTALLATION FLOW

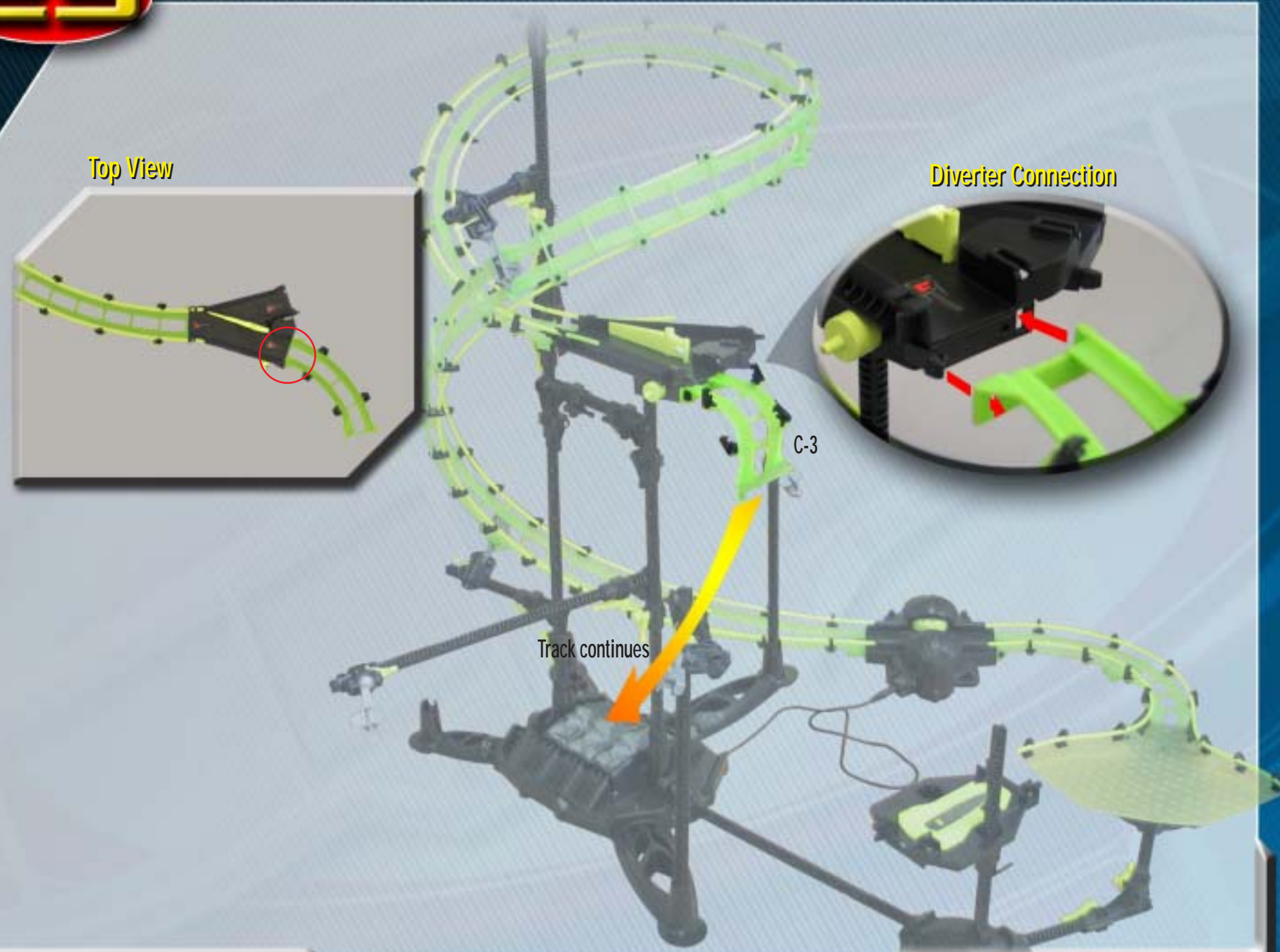



30

Top View

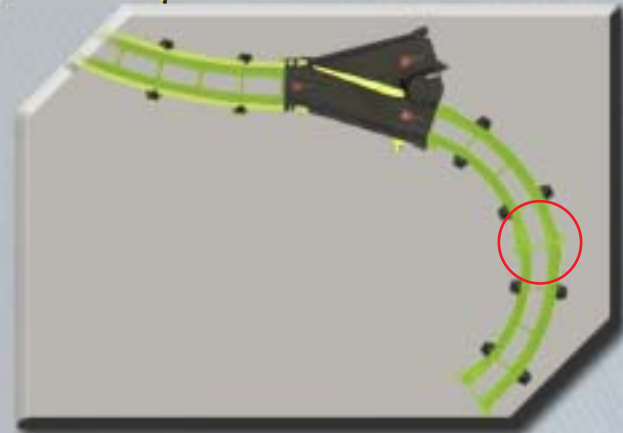

31

Top View

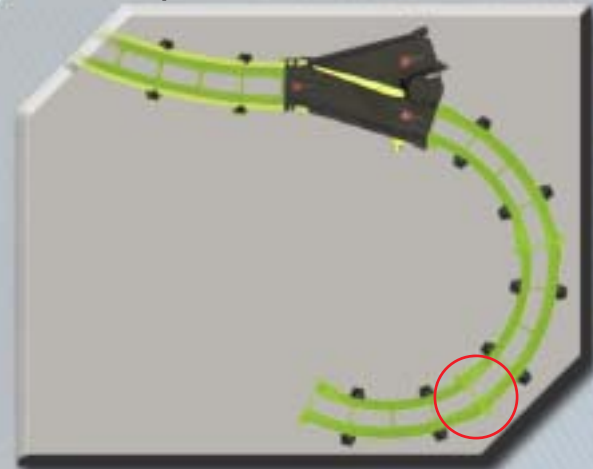

Connection 1

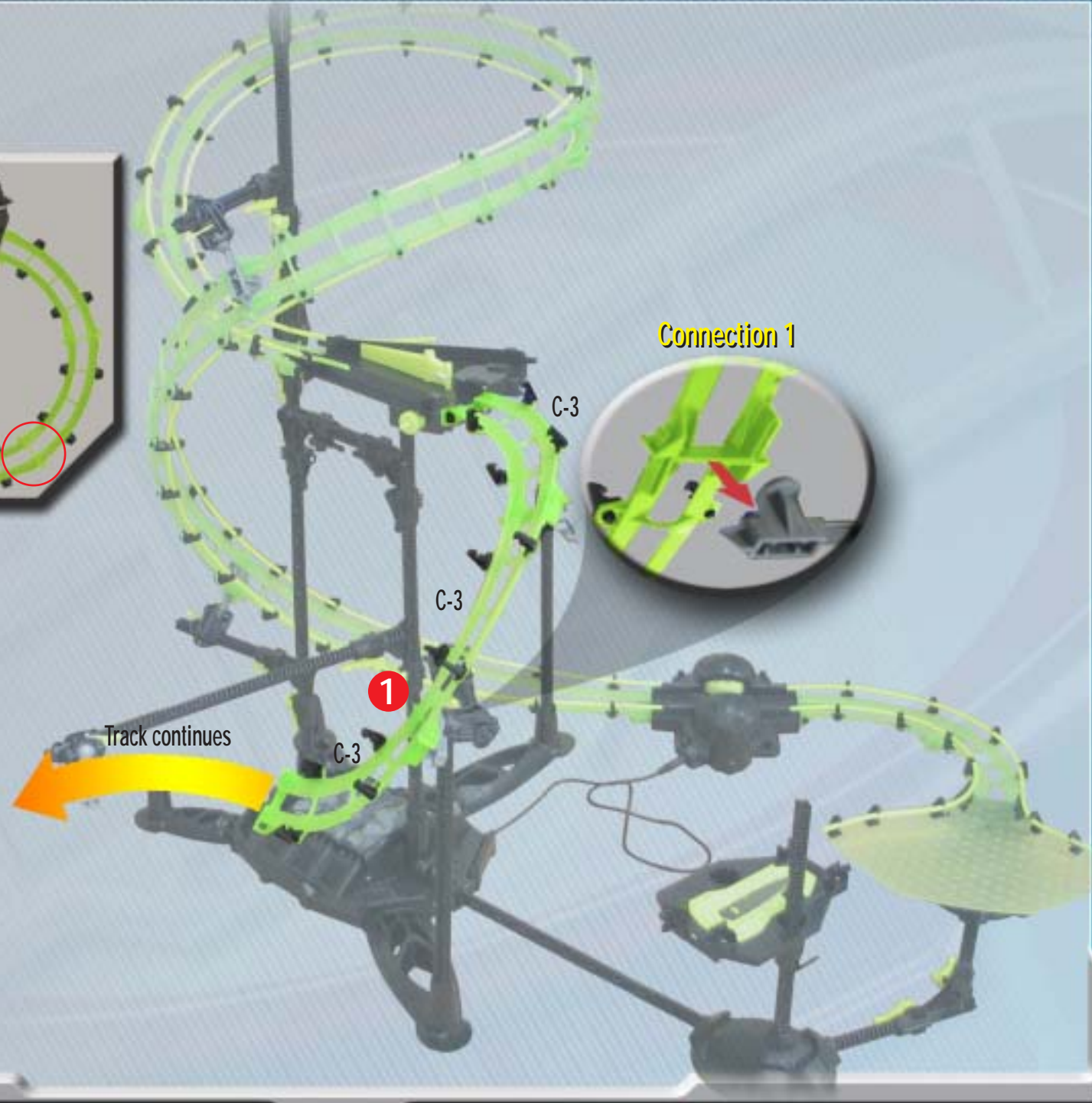



32

Top View

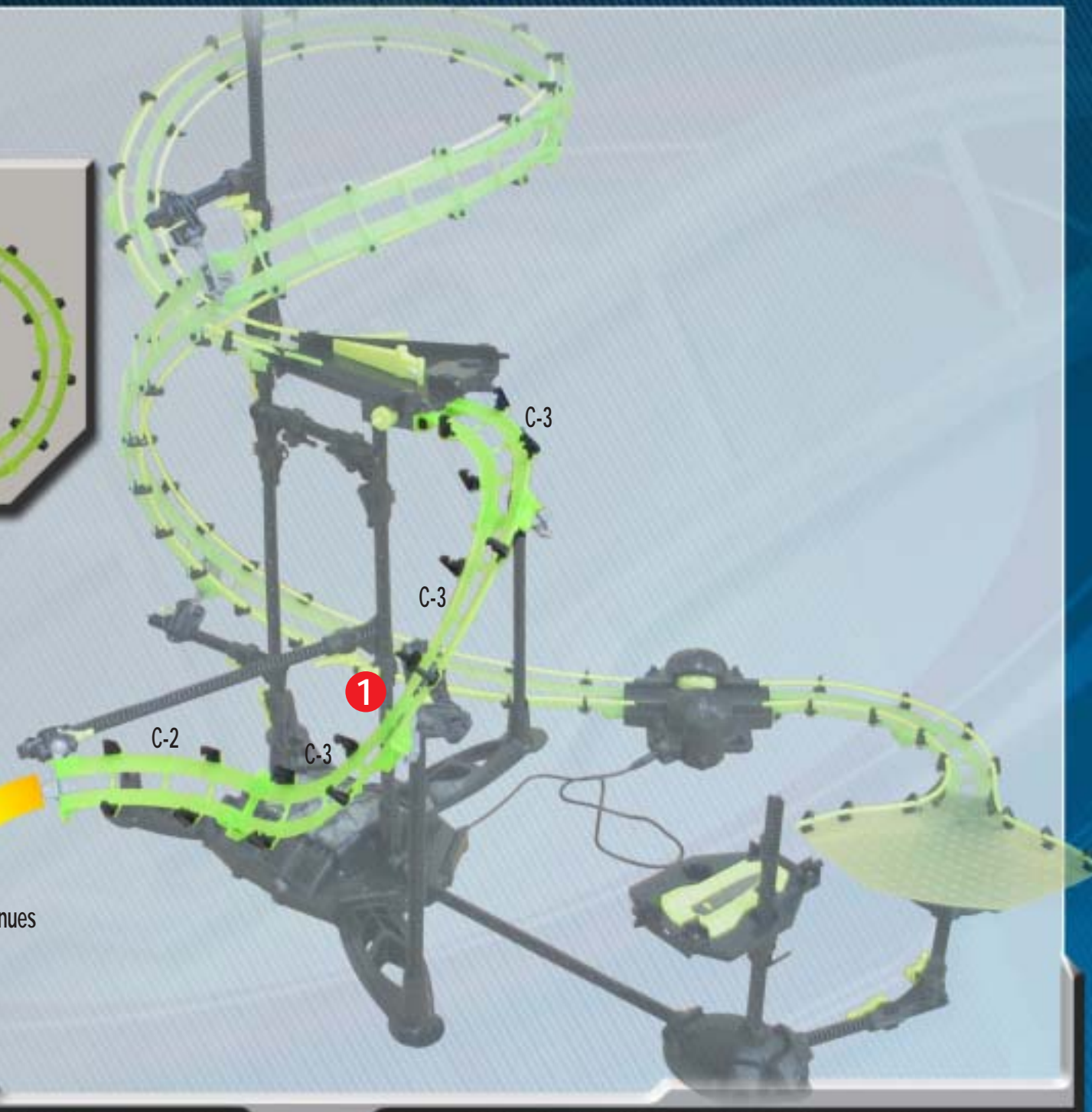
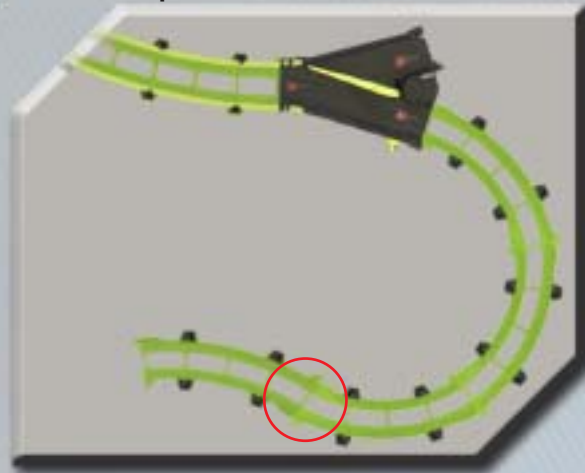

Track continues

33

Top View

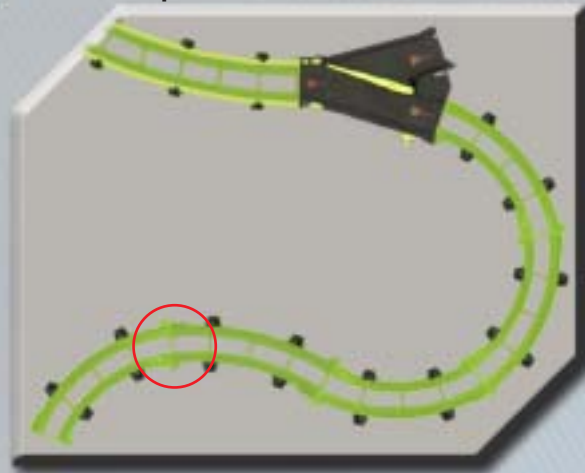

Connection 2

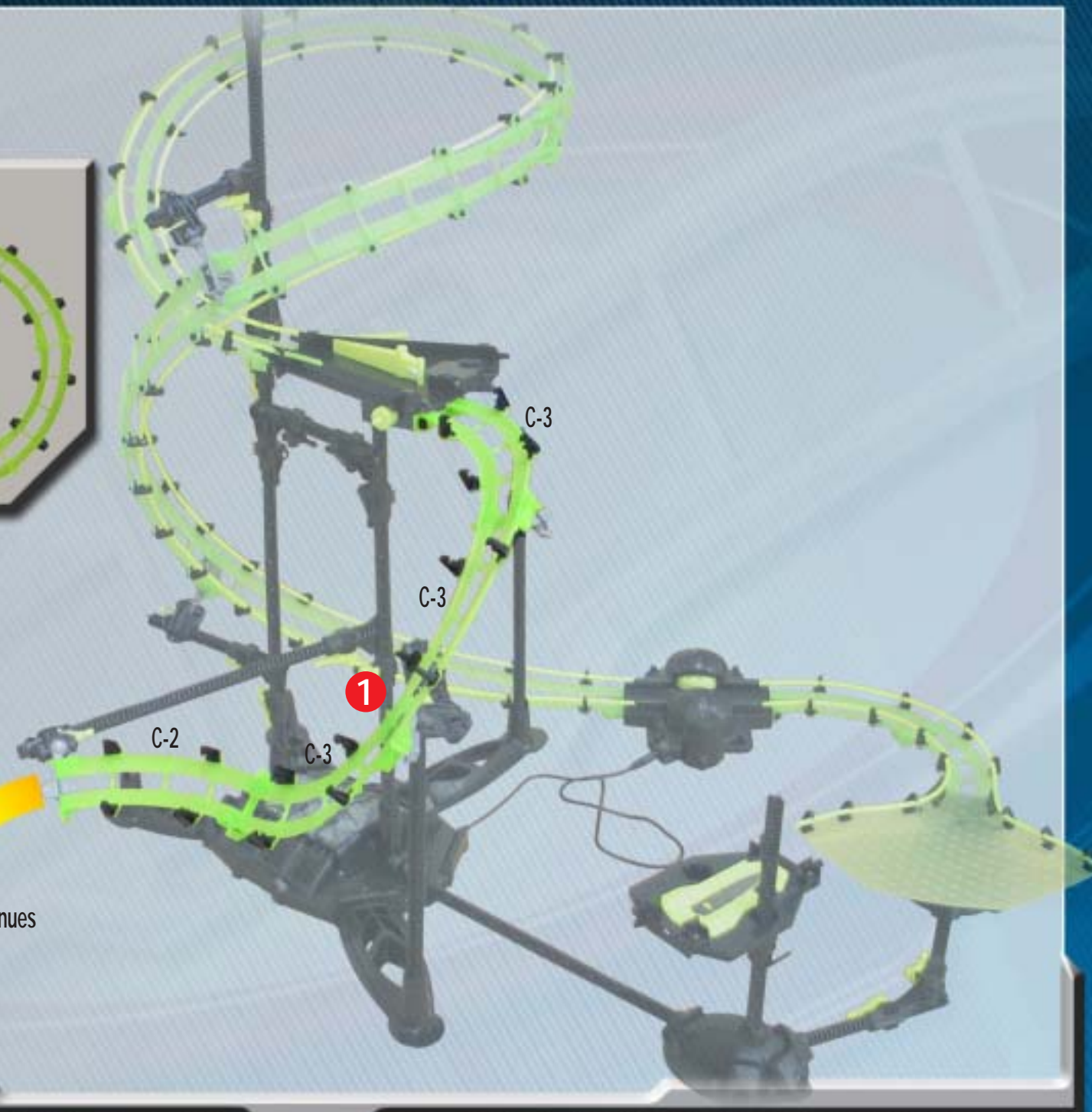

Track continues



34

Top View



35

Top View

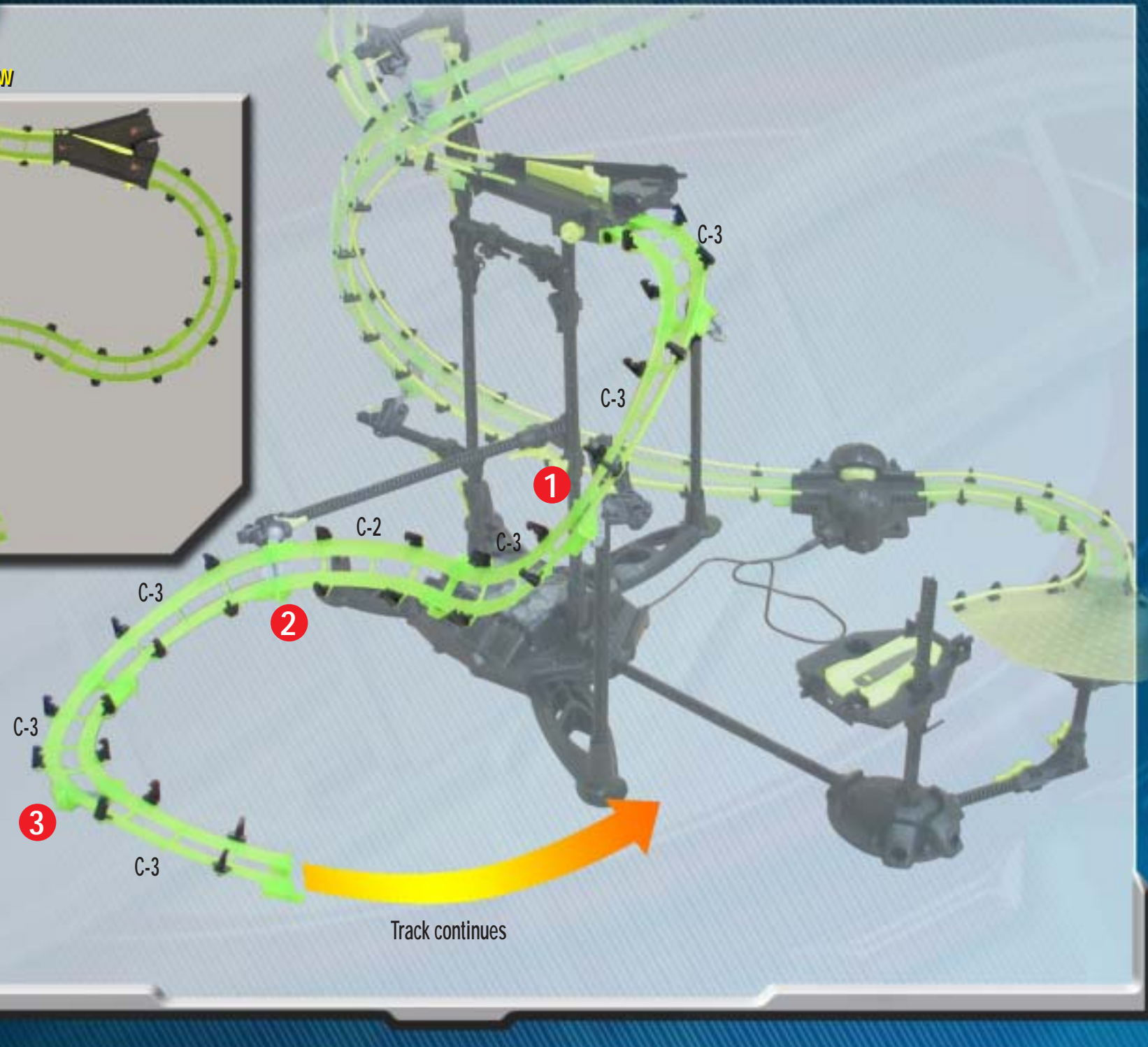
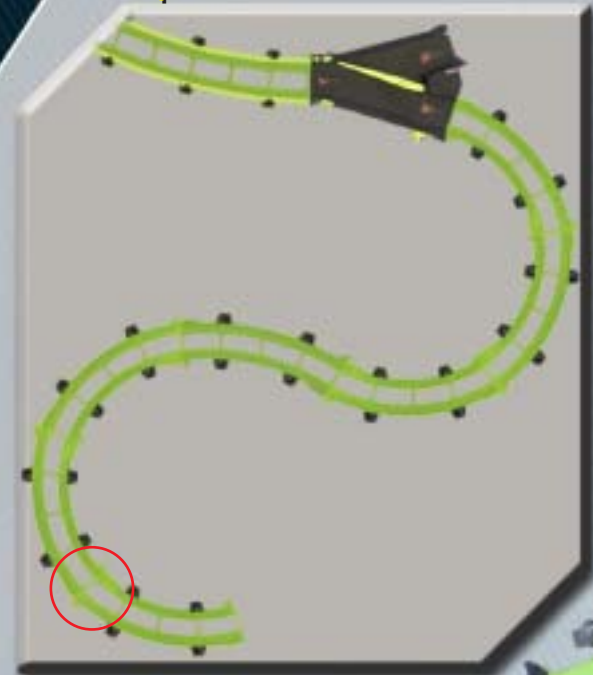



36

4.875" (12.4 cm)

Connection 3

Parts required:

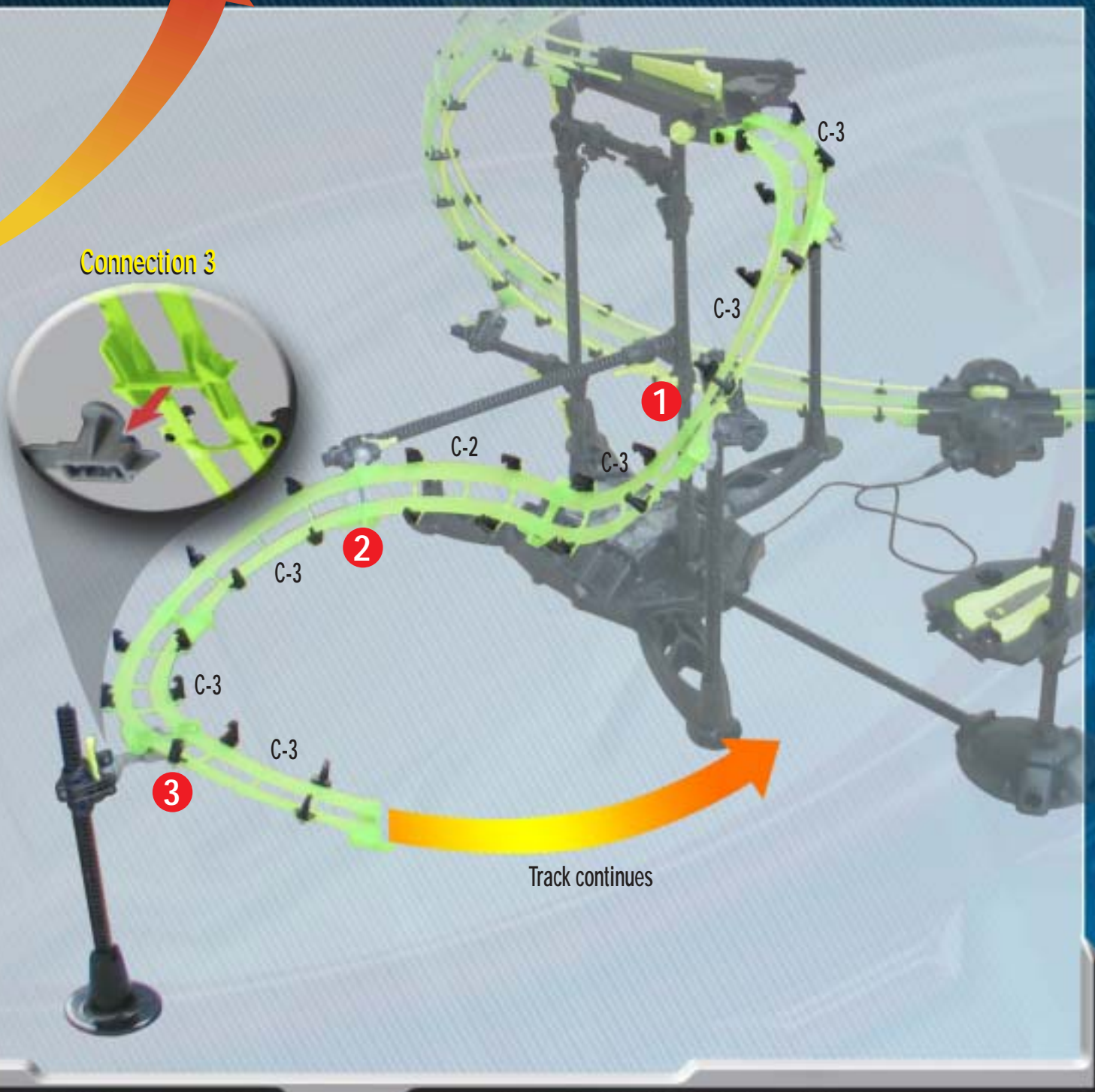

37

Top View

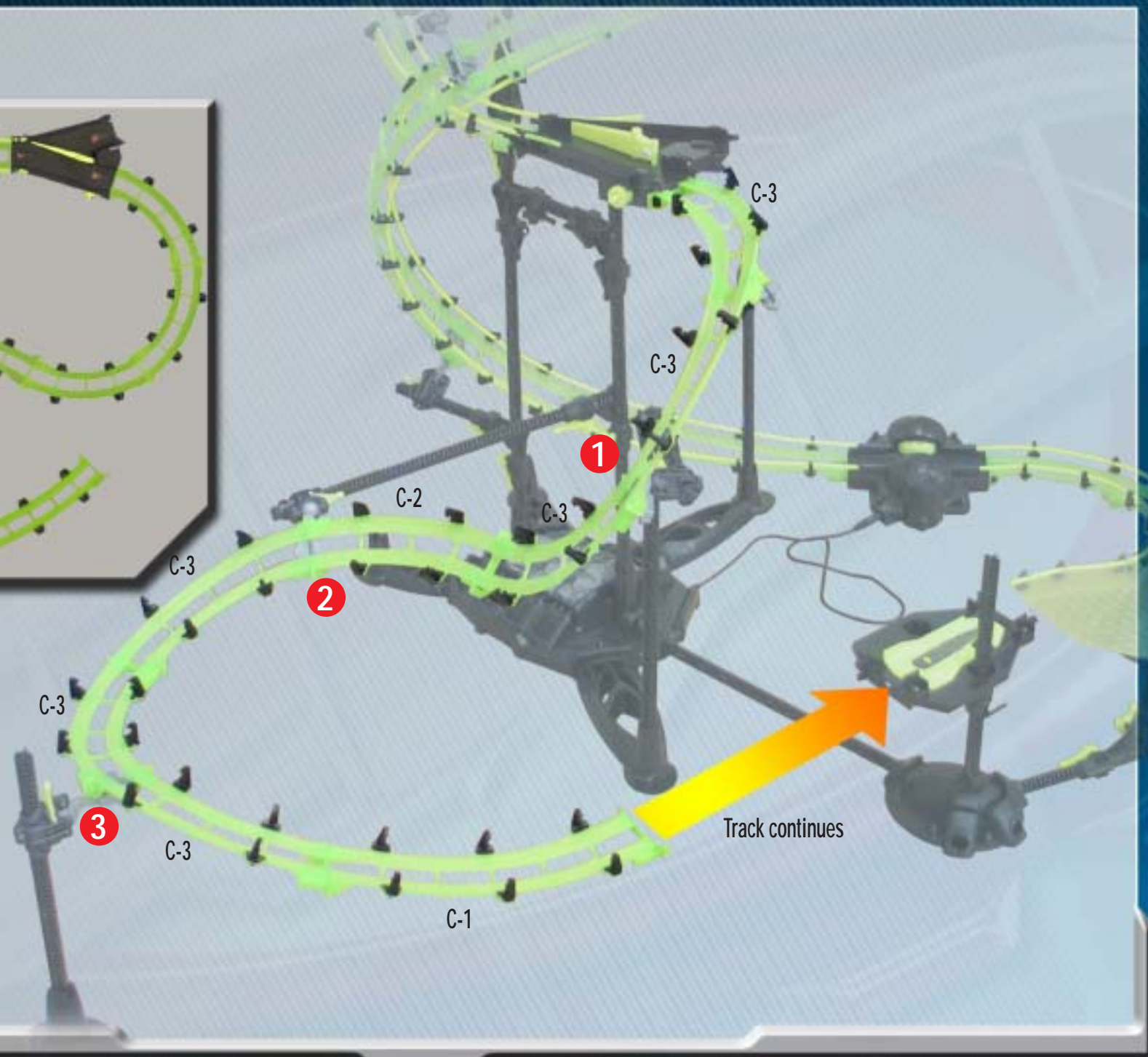



38

Top View



Flip Jumper Connection



1

2

3

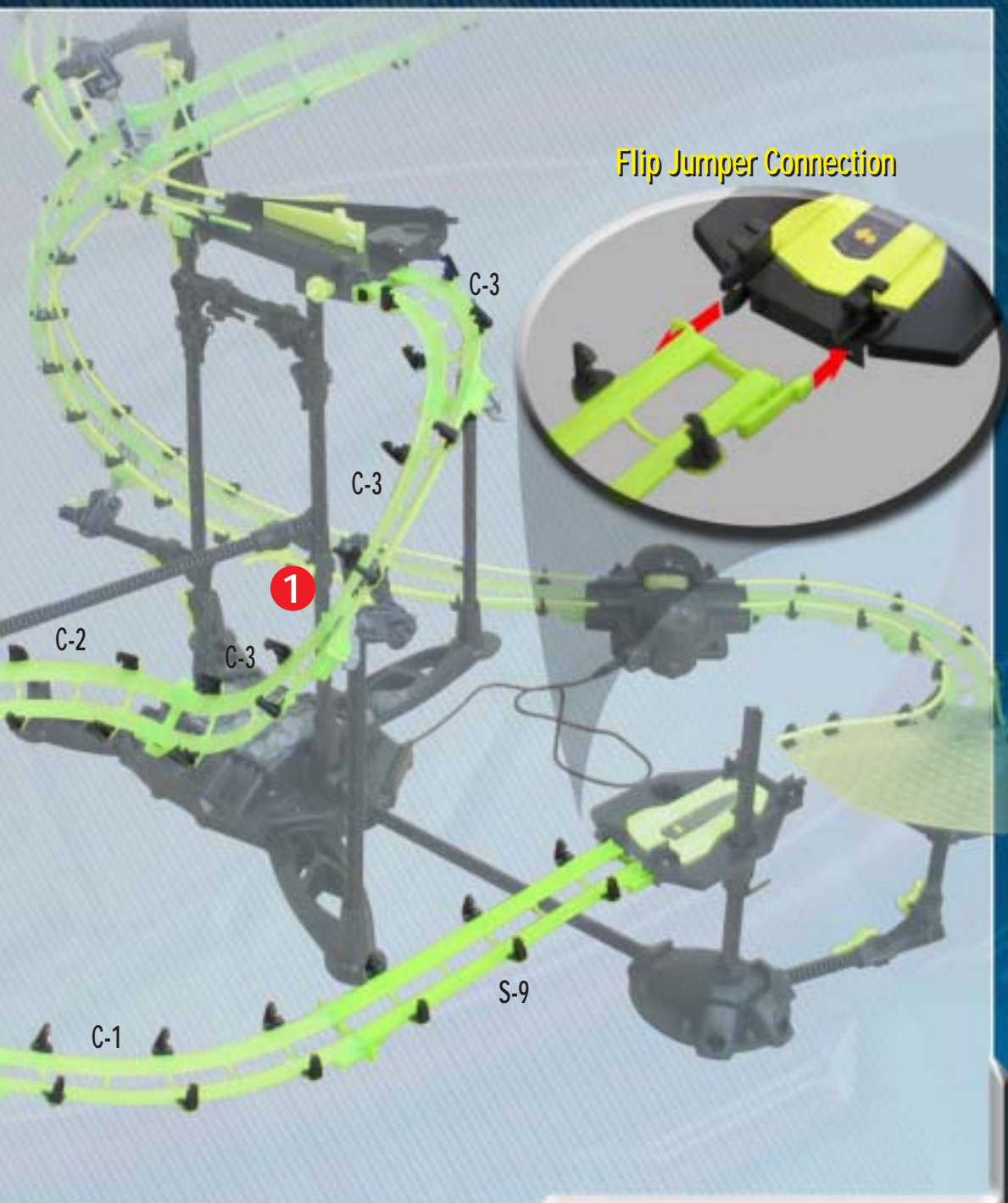

39

PHASE 3 TRACK GUARDRAILS

1 Start here.



2 Snap guardrails onto every clip.



3 Snap guardrails onto Flip Jumper.



Parts required:



(2) 67" (170 cm) Guardrails

67" (170 cm) Guardrails

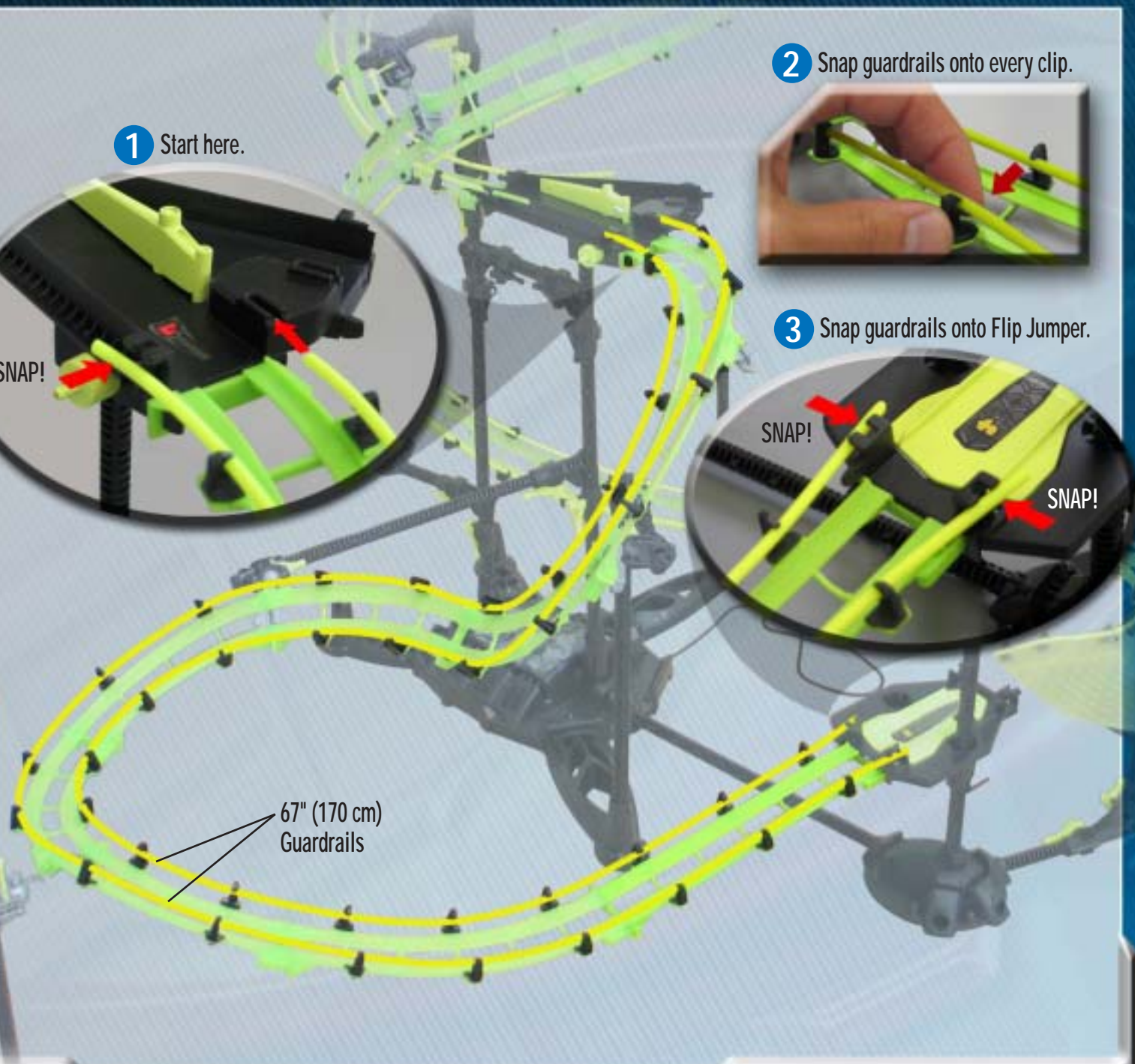



40

3.25" (8.3 cm)

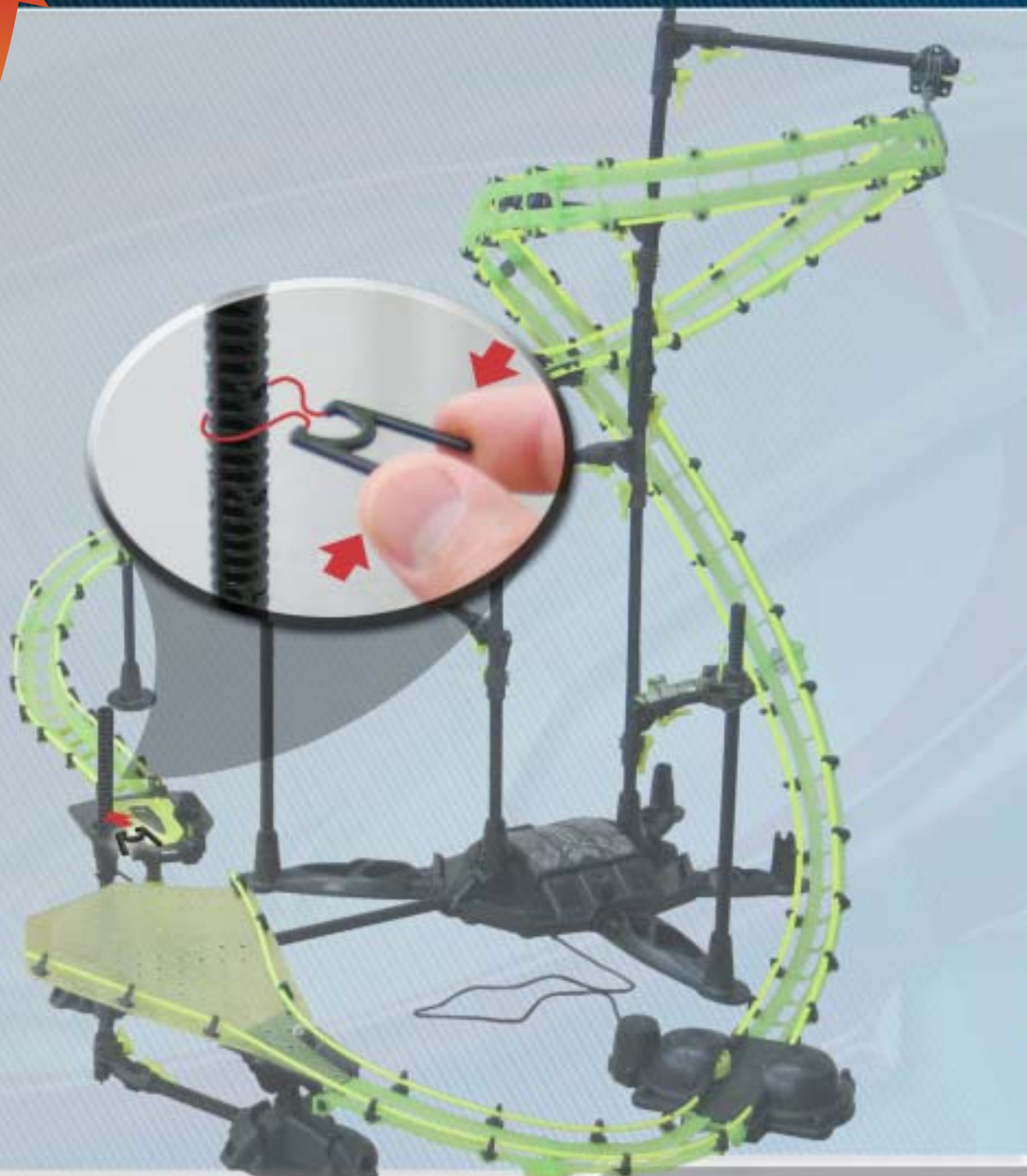
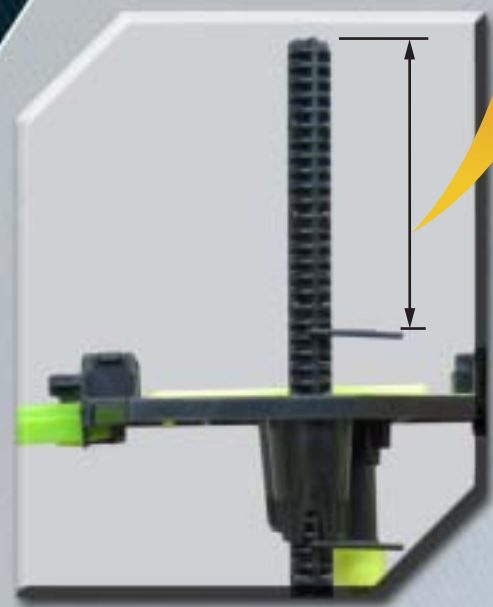

Parts required:

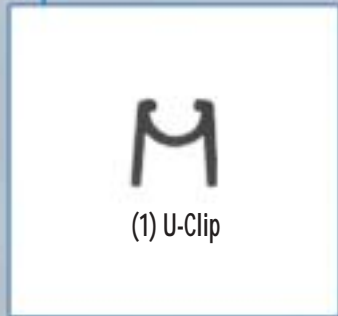

41



Parts required:

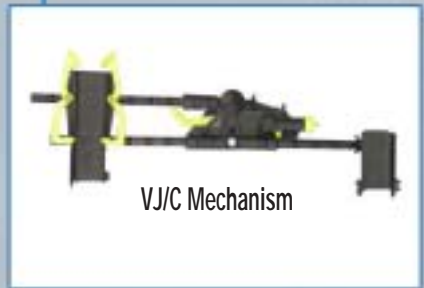



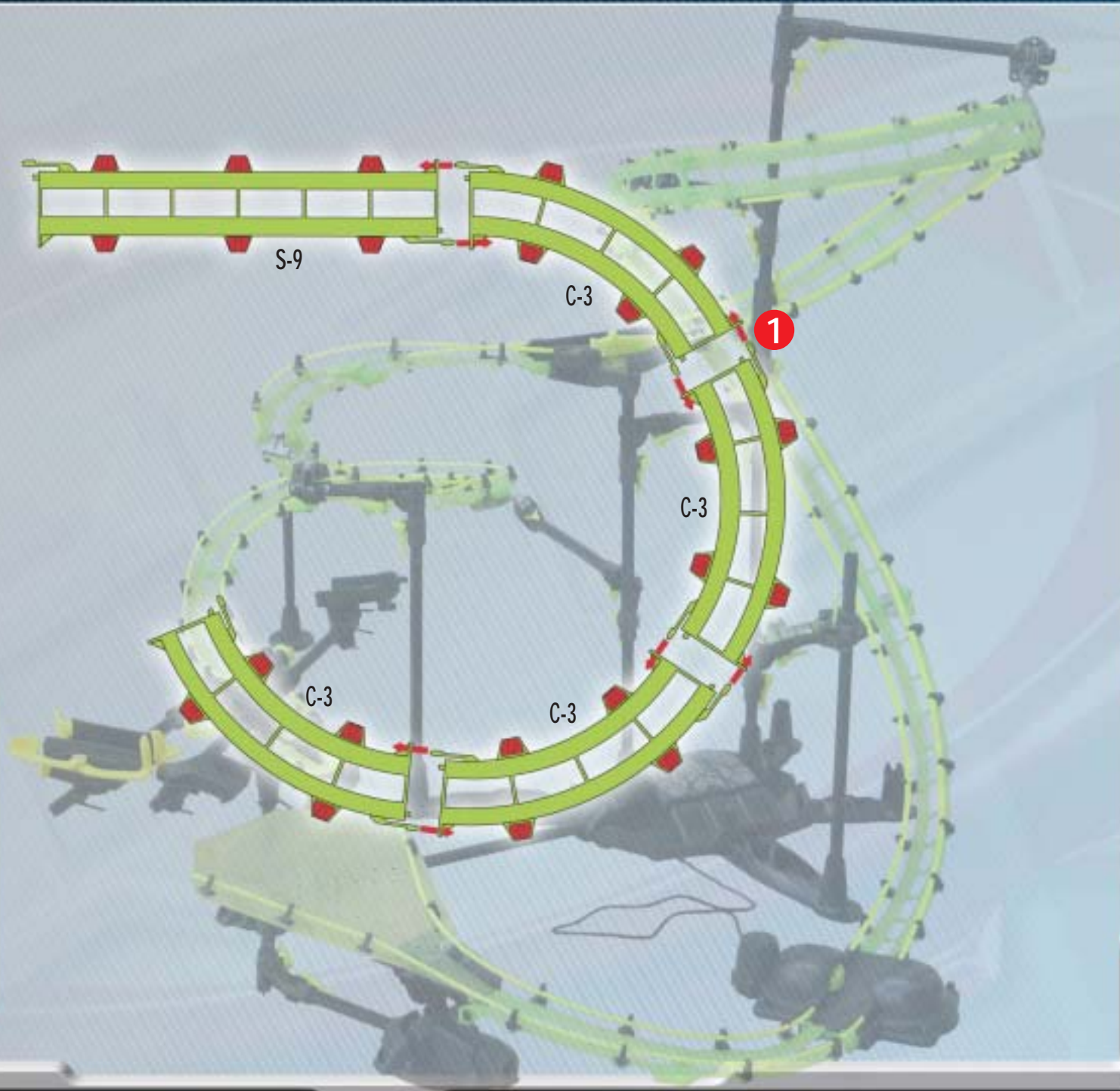

42

# PHASE 4 TRACK ASSEMBLY



Parts required:

	
(22) Clips	(4) C-3
	
	(1) S-9

43

# PHASE 4 TRACK INSTALLATION FLOW

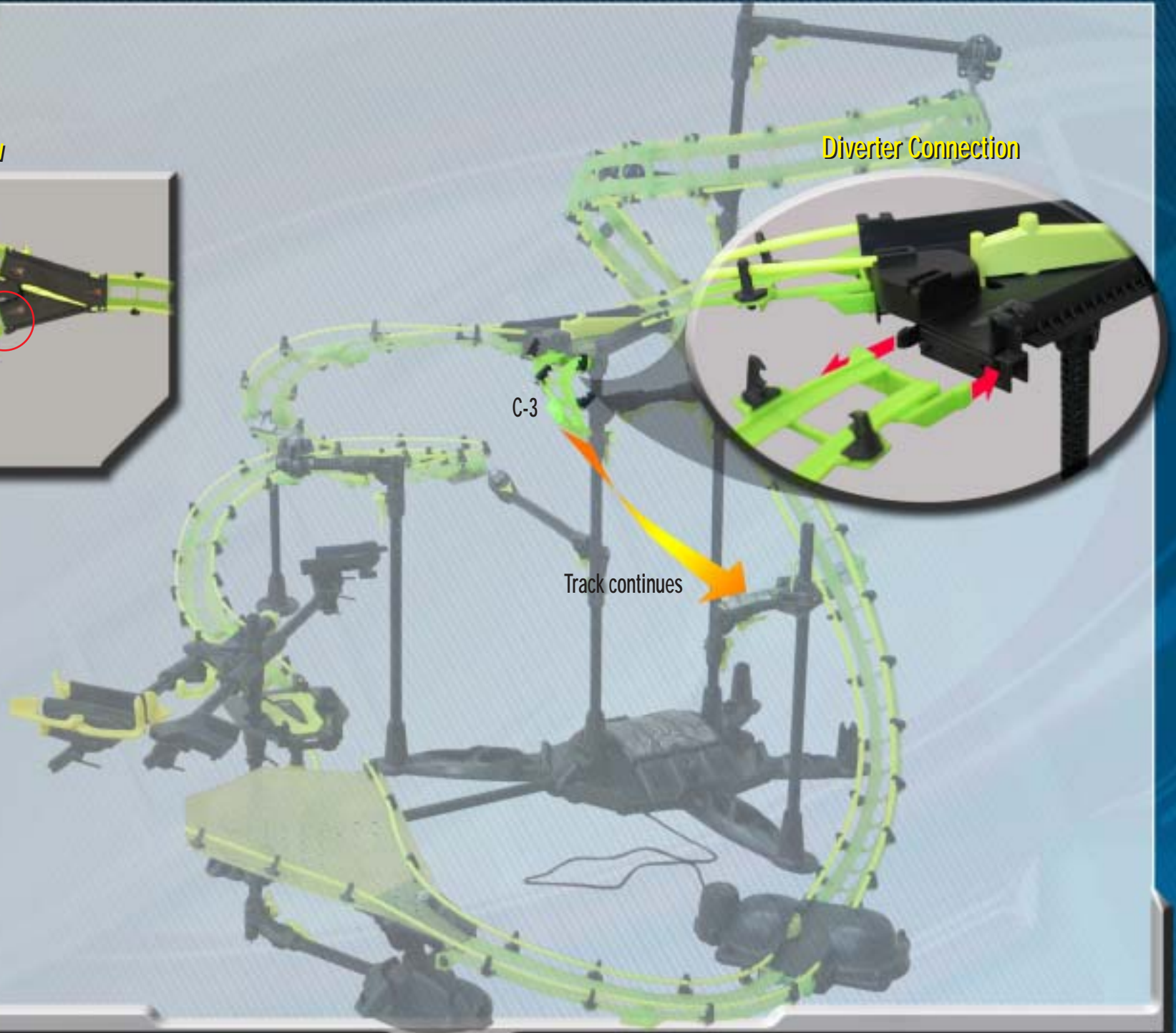
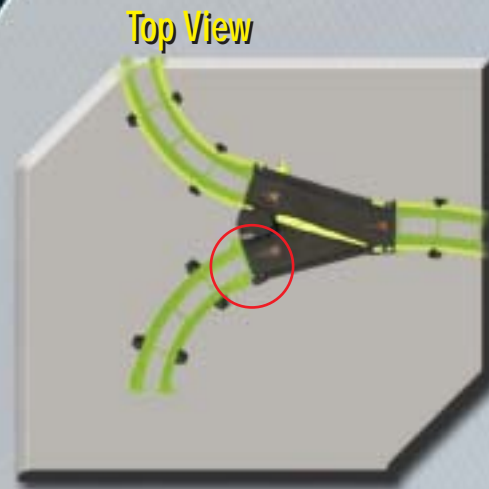



44

Top View

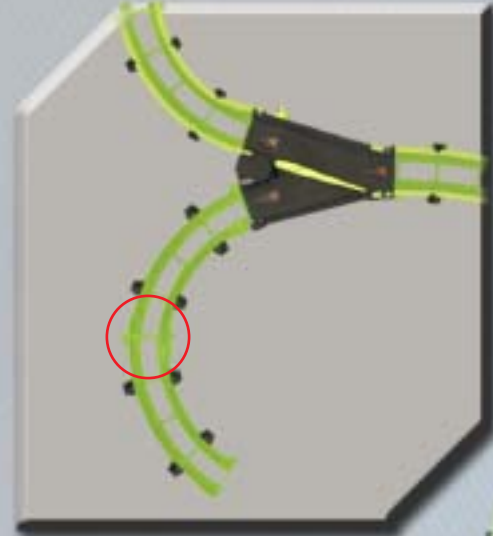

C-3

C-3

Track continues



45

Top View

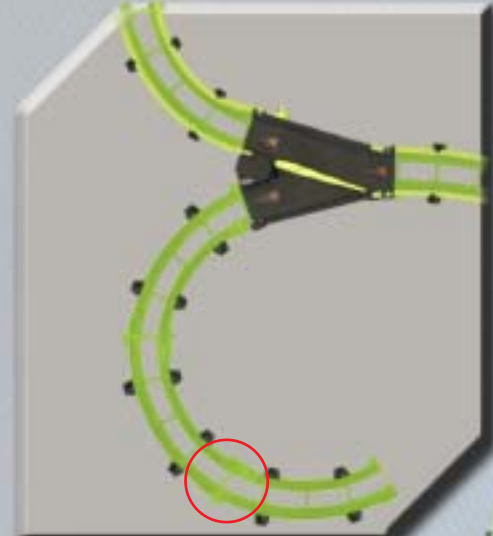

C-3

C-3

C-3

Track continues

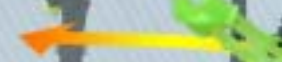



46

Top View



Connection 1



Track continues

1

47

VJ/C Mechanism Connection

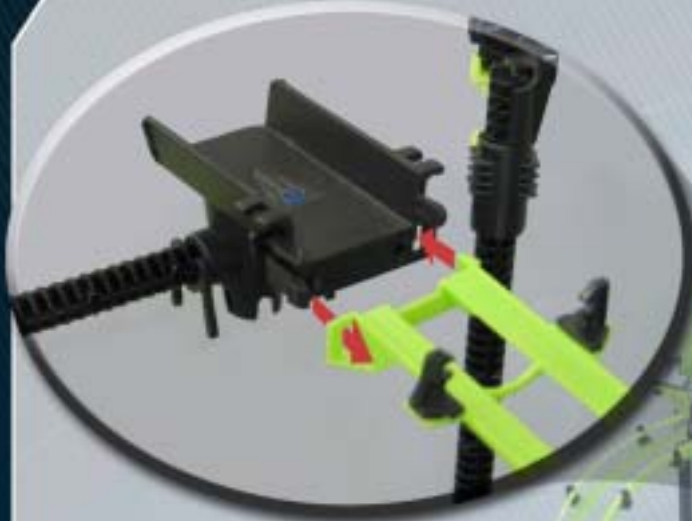

1



# 48

## PHASE 4 TRACK GUARDRAILS

2 Snap guardrails onto every clip.



1 Snap guardrails onto Diverter.



3 Snap guardrails onto VJ/C Mechanism.

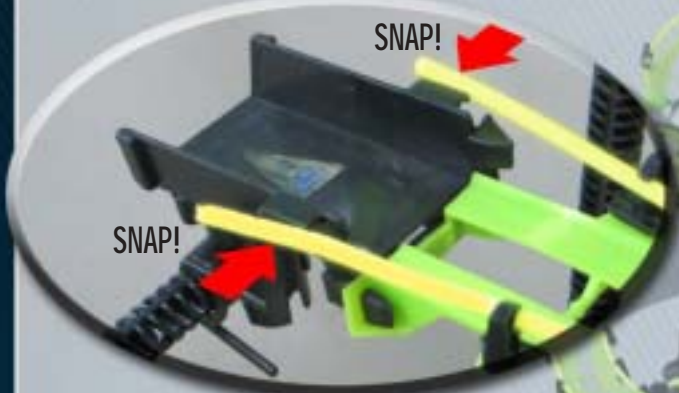

40" (101.6 cm) Guardrails

SNAP!

SNAP!

SNAP!

# 49

## POWER CONNECTIONS

Apply labels 11, 12, 13 and 14.

Top View

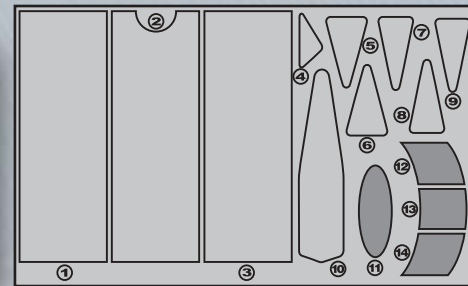

11

Parts required:



Airstunt Pump



Connect 3D Base cord to Booster.





# READY TO PLAY



# HOW TO PLAY

## Play Mode 1

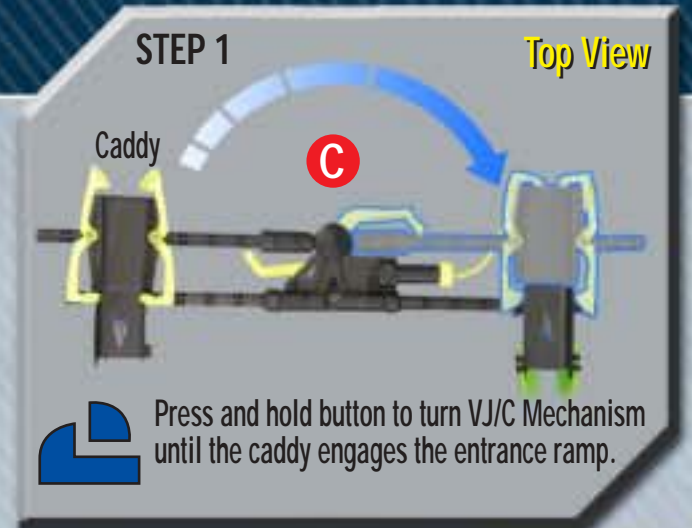

## Play Mode 2

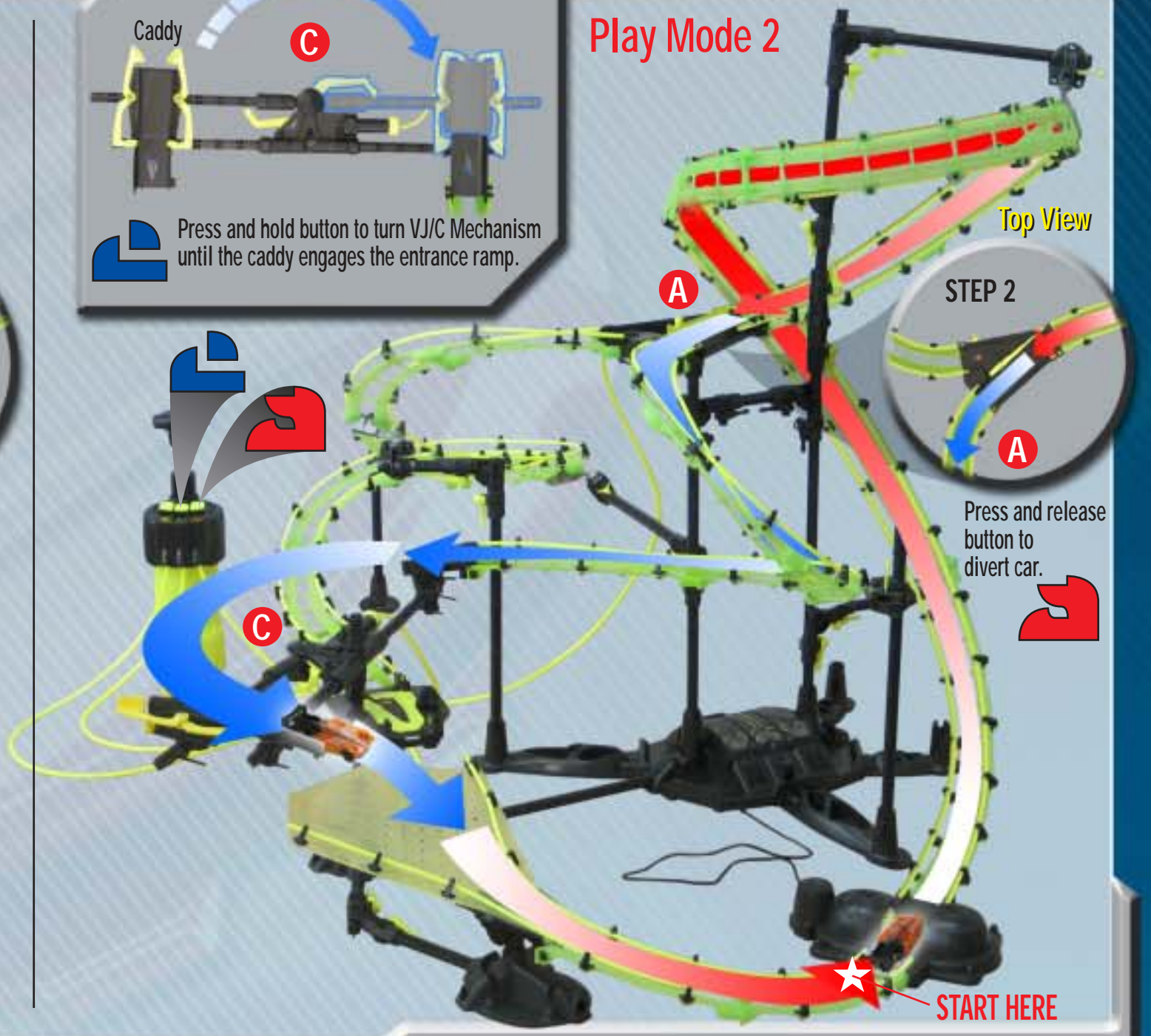



# ALTERNATE LAYOUTS



## JUMP MASTER™ VEHICLE

Designed for jumps.

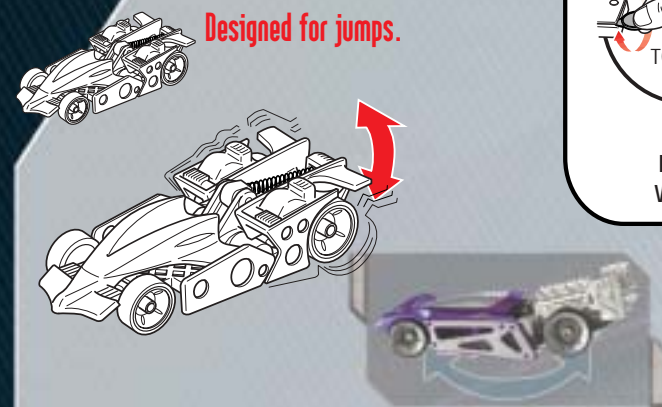

By adjusting the amount of weight and where you place it on the chassis, you can tune the performance of your Tech Trax™ vehicle to match the unique design of your Tech Trax™ set. As a general rule, lighter cars work better on tall track sets and heavier cars work better on downhill track sets.

**TRY FRONT-LOADED FOR BETTER LOOPS**

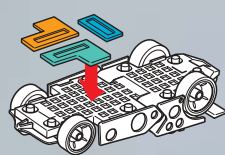

**TRY BACK-LOADED FOR BETTER JUMPS**

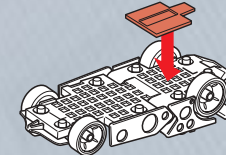

**BALANCED FOR OVERALL PERFORMANCE**

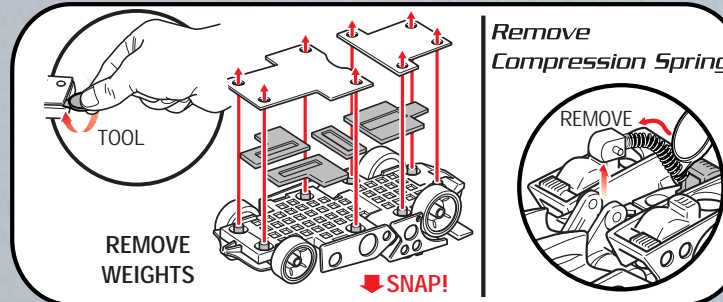
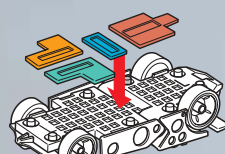

## ASSEMBLE REAR END

### 1 Rear End Wheels

REAR END/TOP SIDE

NOTE: Smaller wheels are in front, larger wheels for rear.

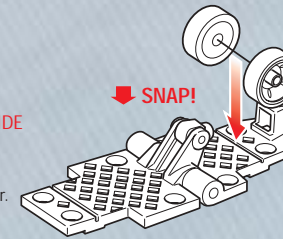

### 2 Engine

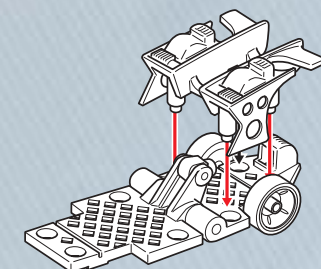

### 3 Rear Bottom Weights

REAR END/BOTTOM SIDE

FLIP OVER

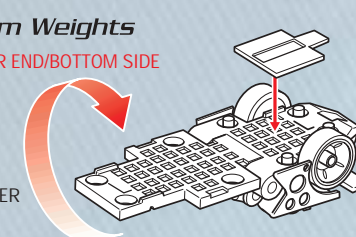

### 4 Rear Bottom Cover

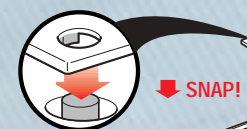

## ASSEMBLE FRONT END

### 5 Front End Wheels

FRONT END/TOP SIDE

NOTE: Smaller wheels are in front, larger wheels for rear.

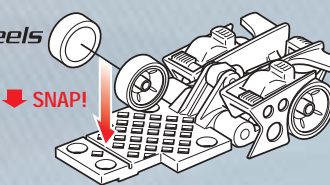

### 6 Hood

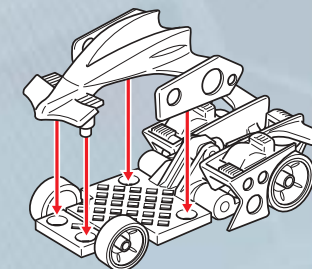

### 7 Front Bottom Weights

FRONT END/BOTTOM SIDE

FLIP OVER

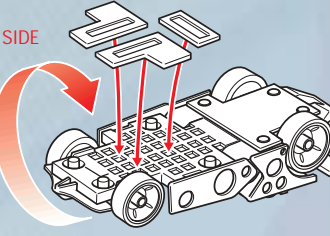

### 8 Front Bottom Cover

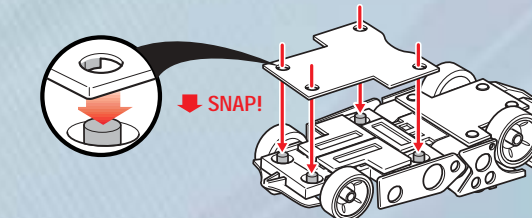

### 9 Add Compression Spring

REAR END/TOP SIDE

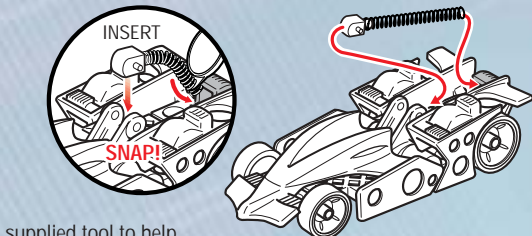

Use supplied tool to help remove compression spring.



# TROUBLESHOOTING AND TIPS



The T2P connector can be used as an adaptor for connecting the track pieces of TECH TRAX™, to existing Hot Wheels® track.

Where Guardrail ends, be sure to carefully flex the ends outward, so that it won't impede the vehicles movement.



To use the 3XL, simply slide it onto one of the Rod pieces. (Note: Be sure the "Locking Key" is in the open position.)

Position along the rod where desired, and then turn the Lock key to secure.



To attach the track, take the section where two tracks are joined, and simply slide into the rotating clip unit.

By loosening the Locking Key, you can now set the angle of the track where you desire.

To remove the track from the Rotating Clip, simply squeeze its ends outward, and pull track out of the groove.



To use the 45/90/T-Joints, simply slide a Rod into the open face of the joint, and then close over the cover element. (Note: Be sure the "Joint Key" is rotated into its "open" position.) To lock its position on the rod, rotate the Joint Key 90 degrees.

**Fine tuning of the set is required to yield optimum performance.**



# COLLECT AND CONNECT TECH TRAX™ SETS



B3736 Flex Loop™  
Stunt Set

B4687 Trigger Flip™  
Stunt Set

B4686 Power Swing™  
Stunt Set



B6529 Crash Chamber™  
Stunt Set

## AVAILABLE CARS:



B4681 Jump Master™



B4682 Turbo Torque™



B4683 Power Pivot™

Each sold separately, subject to availability. Colors and decorations may vary.



