



# Learn Through Music

## INSTRUCTION SHEET

Please keep these instructions for future reference as they contain important information.

Thank you for purchasing the **Learn Through Music** system. The **Learn Through Music** interactive early learning system helps teach preschoolers fundamental lessons through the magic of music. The rhythm, rhyme and repetition of musical sounds and lyrics are time-honored and time-tested tools that capture children's attention and imagination and help them to absorb and remember basic concepts. Because music engages a child's entire self - mind, body and soul - putting lessons to music makes it fun and easy for children to retain new information.

Each **Learn Through Music** cartridge features:

- Specific, age-appropriate learning lessons
- A wide range of lyrical & rhythmic activities
- A variety of visual & audio content
- Diverse curriculums based on beloved characters

### WHAT'S INCLUDED

Your **Learn Through Music** system consists of two main components:

1. The main learning unit, which includes:
  - Touch-sensitive, light-up learning screen
  - 2 arrow buttons
  - 2 mode buttons (music note and question mark)
  - Interactive microphone
2. 1 **Learn Through Music** cartridge

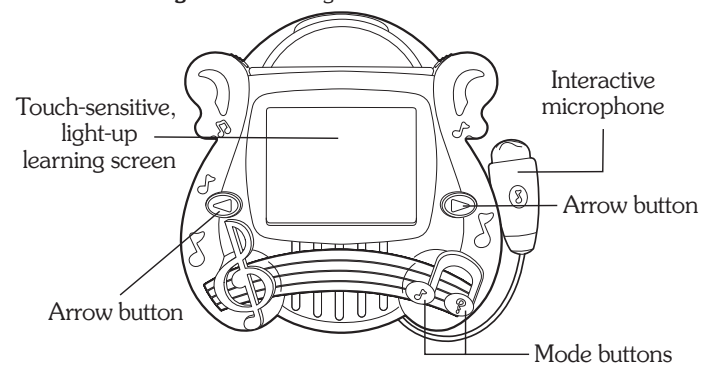

### BEFORE YOU BEGIN

- Please remove and discard the "Try Me" pull-tab from the back of the main learning unit.
- An **ON/OFF/VOLUME** switch is located on the back of the main learning unit. Be sure the switch is in either the **LOW VOLUME** or **HIGH VOLUME** position.

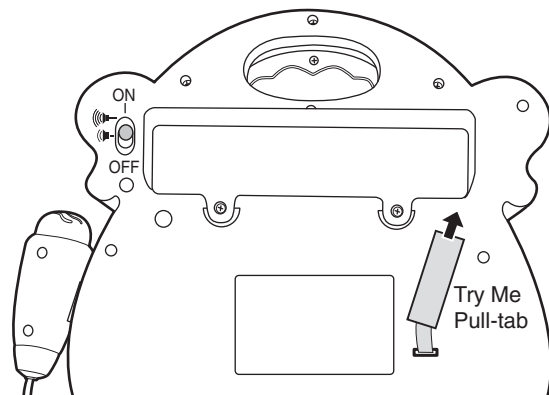

### HOW TO PLAY

- Insert the cartridge into the main unit as shown. Be sure you hear the cartridge "click" into place before you begin play.
- Press any button or touch the screen to begin play.
- The **Let's Share the Day Together™** cartridge consists of 15 different play-screens.
- Each play-screen has two modes of play:
  - Music/Identify Mode** - press the **MUSIC NOTE** button to replay the music that you hear when you first arrive at each play-screen.
  - Question Mode** - press the **QUESTION MARK** button to hear and repeat questions.
- Press the arrow buttons to advance to the next screen or rewind to the previous screen.
- At any time you can press the button on the microphone to sing along!
- To remove or replace the learning cartridge, simply push the two slide buttons located on the sides of the cartridge outward to release the cartridge.

**NOTE: If there is no cartridge inserted into the main unit you can still play:**

- Press the music button to hear songs.
- Press the screen to step through the songs note by note.
- Press the **QUESTION MARK** button to play follow the lights.

Look for other cartridges also available for use with the **Learn Through Music** system.

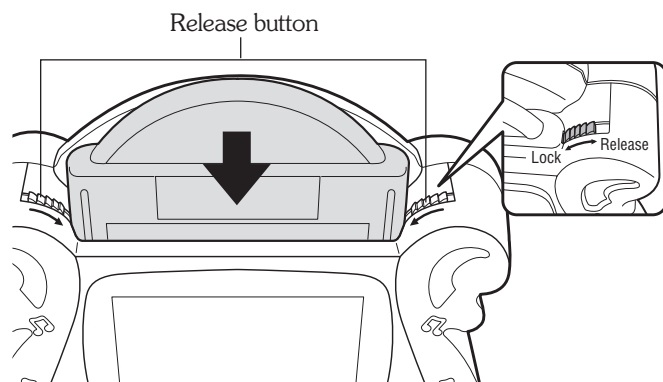

### THE STORY

Barney, BJ & Baby Bop would like to spend the day with you!

Barney invites you to join him and his friends for a day full of fun and learning. Throughout the adventures, you and Barney will visit various friends and places.

Along the way you will learn:

- The times of day (morning, noon & night)
- Color, shape, and pattern recognition.
- Listening for and distinguishing between various sounds.
- Sharing, taking turns & practicing good manners such as saying please and thank you.

**Frame 1** The first frame acts as an introduction as Barney invites you to join him and his friends on a fun-filled day!

**Frame 2** Teaches object and color recognition.

**Frame 3** Introduces you to some of Barney's bird friends.

**Frame 4** Teaches you about the weather.

**Frame 5** Barney takes you on a bike ride!

**Frame 6** Teaches you about safety using shapes and colors.

**Frame 7** Time for a snack! Help Barney find his favorite foods.

**Frame 8** Teaches manners while also learning the colors of different foods.

**Frame 9** Teaches listening and sound recognition.

**Frame 10** Teaches sharing.

**Frame 11** Teaches pattern repetition and sound recognition. Barney, BJ, and Baby Bop each have their own drum with its own sound! Press the question mark to see and hear a pattern. Then try to repeat it by pressing the correct sequence of drums.

**Frame 12** Time to clean up! Help Barney put everything away in its proper place.

**Frame 13** Help Barney find everything he needs to get ready for bed.

**Frame 14** Teaches sound recognition with various nighttime sounds.

**Frame 15** The day comes to an end as Barney sings the "I Love You" song and helps you make a wish on a star!

### TO PLAY AGAIN

To play again, press the right arrow button while on the 15th screen and the cartridge will rewind back to the beginning. Then press the screen or any button to start a new game. If you rewind to the first screen at any time during play, the game will reset. Look for other cartridges also available for use with the **Learn Through Music** system.

### TOY SLEEP MODE

- If the toy is not played with for more than 10 seconds it will prompt the child to continue playing.
- If after another 10 seconds the child does not play with the toy, it will automatically shut-off to preserve battery life.
- Press any button or touch the screen to resume play.

### BATTERY REPLACEMENT

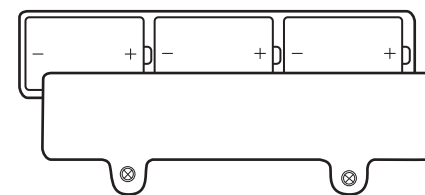

- Unscrew and lift cover away from back of product.
- Replace batteries as shown.

#### Battery Safety Information

Batteries may leak fluids that can cause a chemical burn injury or ruin your toy (product). To avoid battery leakage:

- Do not mix old and new batteries or batteries of different types: alkaline, standard (carbon-zinc) or rechargeable (nickel-cadmium).
- Insert batteries as indicated inside the battery compartment.
- Remove batteries during long periods of non-use. Always remove exhausted batteries from the toy (product). Dispose of batteries safely. Do not dispose of batteries in a fire. The batteries may explode or leak.

- Never short-circuit the battery terminals.
- Use only batteries of the same or equivalent type, as recommended.
- Do not charge non-rechargeable batteries.
- Remove rechargeable batteries from the toy (product) before charging.
- If removable, rechargeable batteries are used, they are only to be charged under adult supervision.

**Batteries included are for demonstration purposes only. For longer life use only alkaline batteries. Requires 3 "C" (LR14) batteries.**



©2002 Lyons Partnership, L.P. All rights reserved. The Barney, Baby Bop and BJ names and characters and the overlapping dino spots and Barney and star logos are trademarks of Lyons Partnership, L.P. Reg. U.S. Pat. & Tm. Off.

Fisher-Price, Inc., a subsidiary of Mattel, Inc., New York, New York 10010 U.S.A.

**PRINTED IN CHINA.**

Manufactured for Fisher-Price. ©2002 Mattel, Inc. All Rights Reserved.

Fisher-Price and the Fisher-Price logo are U.S. trademarks of Mattel, Inc.

Packaging and address should be retained for future reference.

Mattel Canada Inc., Mississauga, Ontario L5R 3W2. You may call us free at 1-800-665-6288.

Mattel U.K. Ltd., Vanwall Business Park, Maidenhead SL6 4UB. Helpline 01628500303.

Mattel Australia Pty., Ltd., Richmond, Victoria. 3121. Consumer Advisory Service - 1300 135 312.  
Mattel East Asia Ltd, Room 1106, South Tower, World Finance Centre, Harbour City, Tsimshatsui, HK, China.  
Diiimport & Diedarkan Oleh: Mattel SEA Ptd Ltd.(993532-P) Lot 13.5, 13th Floor, Menara Lien Hoe,  
Persiaran Tropicana Golf Country Resort, 47410 P.J. Tel:03-78803817, Fax:03-78803867.  
Mattel, Inc., El Segundo, CA 90245 U.S.A. Consumer Affairs 1 (800) 524-Toys.



Questions or Comments?  
**1-888-892-6123**



**B8728/89452 Asst.**



**B8728/89452 Asst.**