

# HWA

## HOT WHEELS AIR™



FOR AGES OVER 6 YEARS

### CONTENTS:

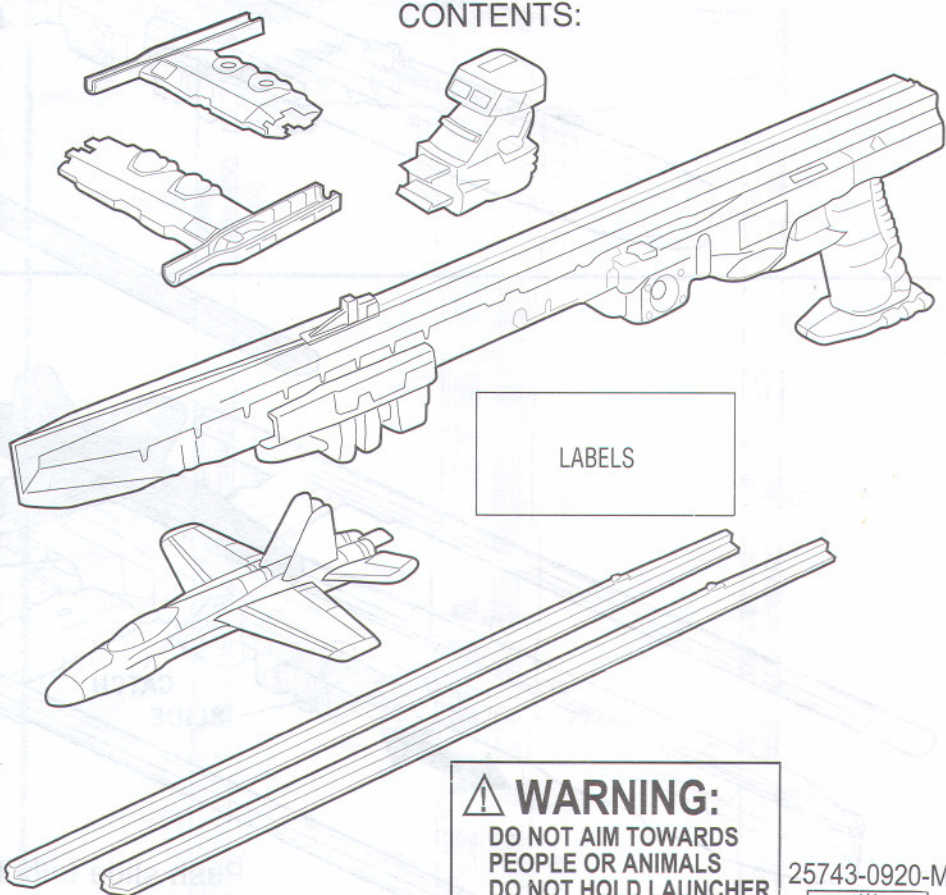

LABELS



### WARNING:

DO NOT AIM TOWARDS  
PEOPLE OR ANIMALS  
DO NOT HOLD LAUNCHER  
CLOSE TO YOUR FACE  
WHEN LAUNCHING

25743-0920-M1



*Keep these instructions for future reference  
as they contain important information.*

# ASSEMBLE LAUNCHER

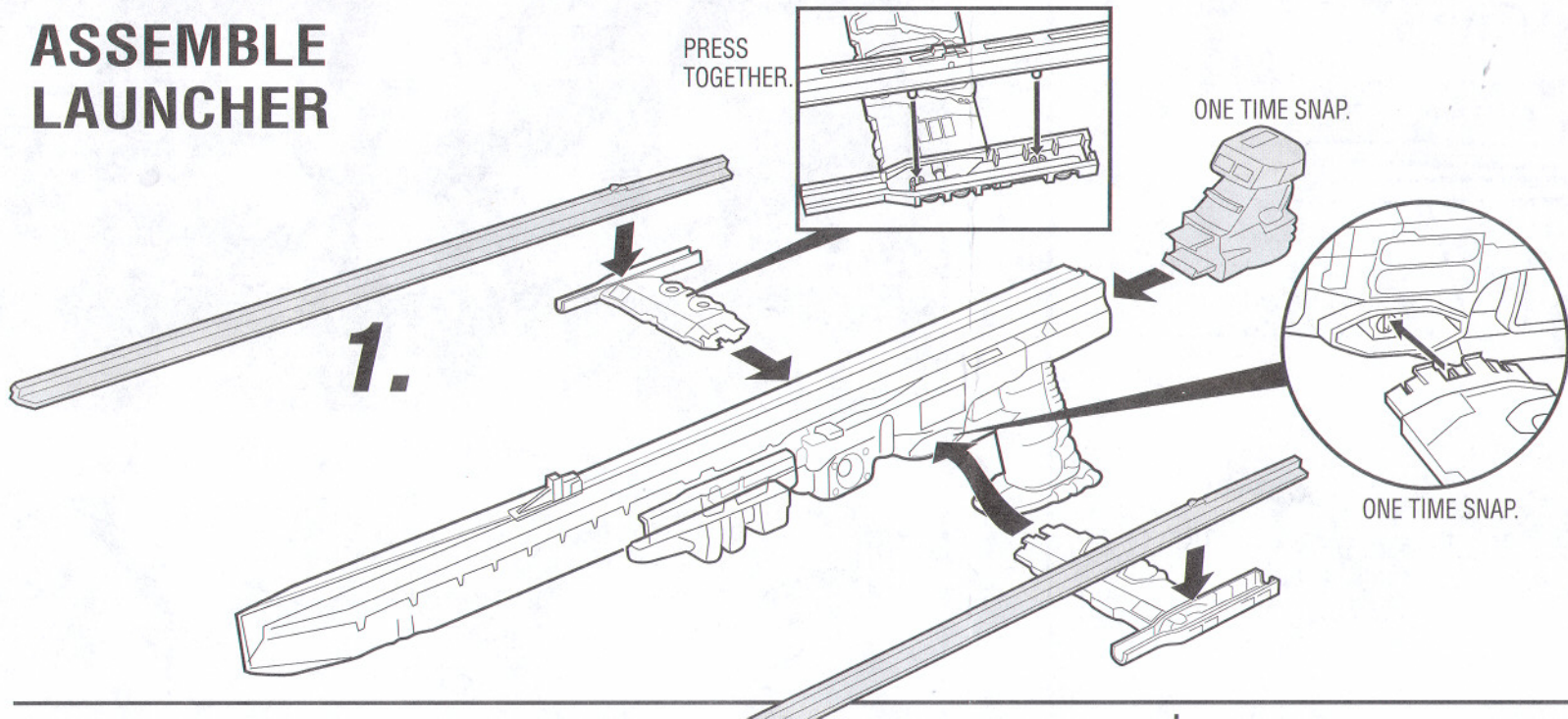



**2.**

Slide nose of plane onto runner to catch the rubber band. Pull back and place rear of plane onto launcher.

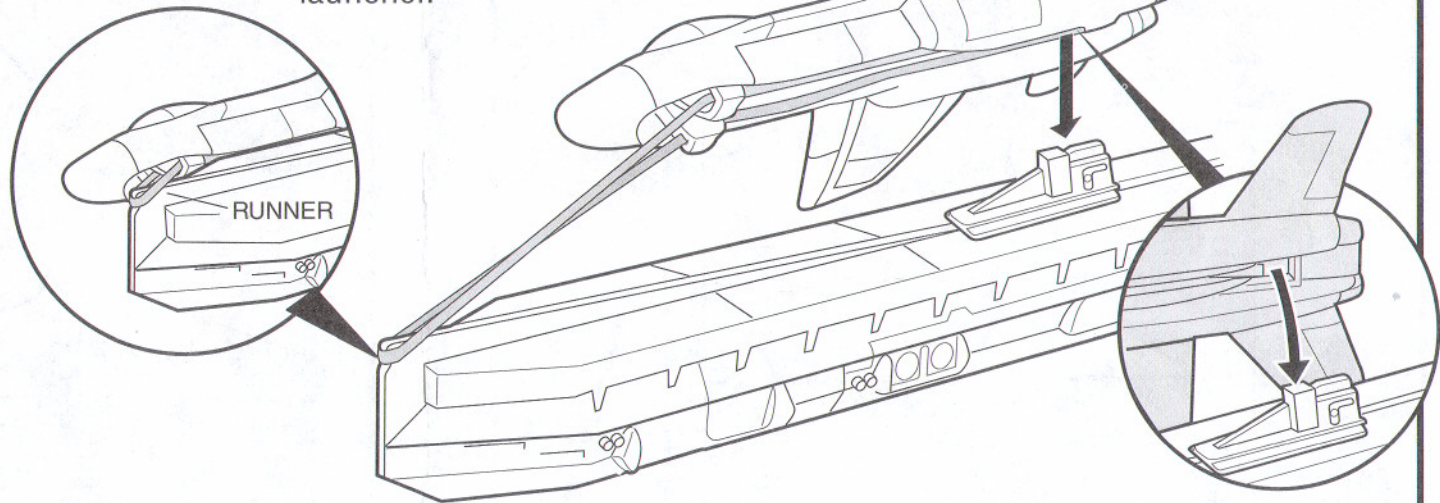

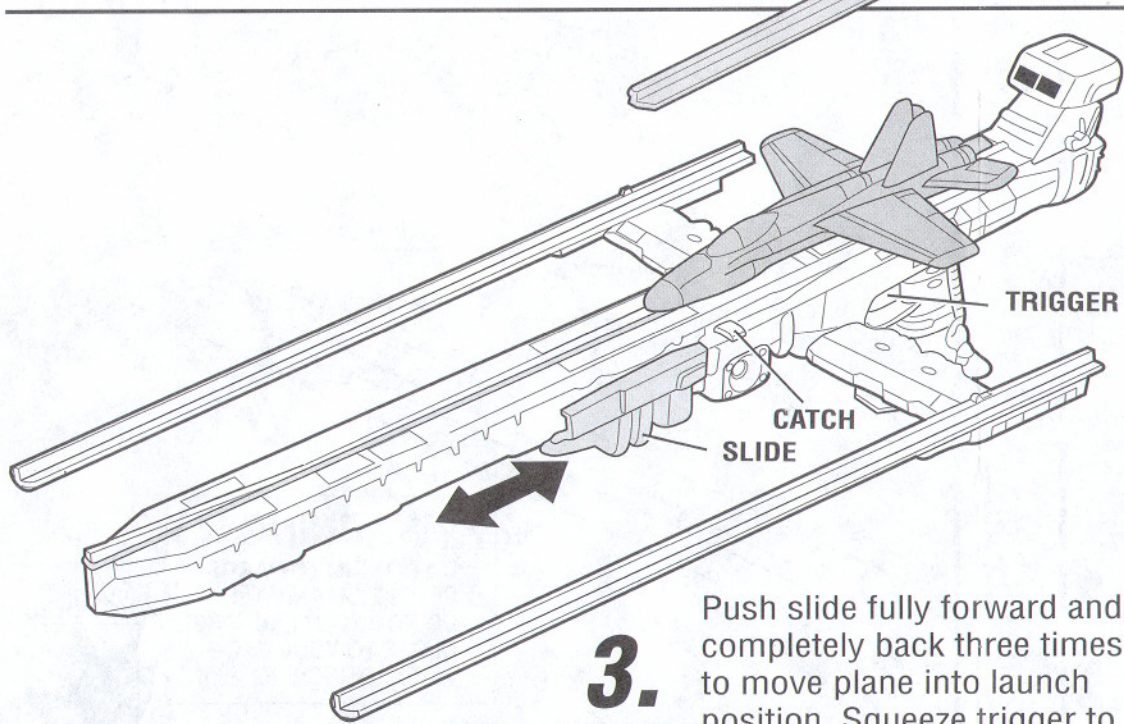

**3.**

Push slide fully forward and completely back three times to move plane into launch position. Squeeze trigger to launch plane.

**4.**

After launch, pull the catch back and outward while holding the slide in back position and return the center launch pin all the way to front.

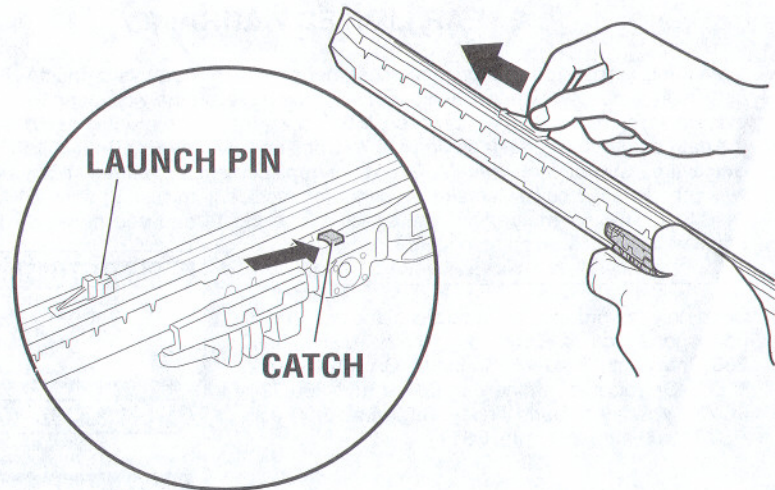

# Add two Hot Wheels® Jetz™ planes for more excitement!

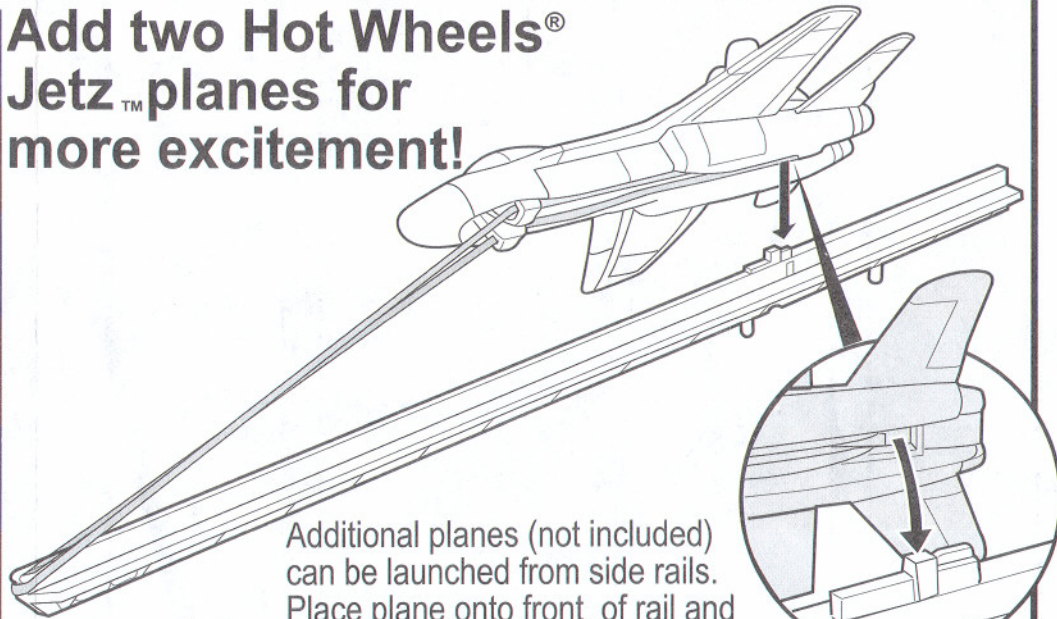

**5.**

Additional planes (not included) can be launched from side rails. Place plane onto front of rail and pull backwards until you can set rear of plane onto launching pin. To launch planes in sequence, pull trigger SLOWLY. To launch planes together, pull trigger FAST.



# ADD LABELS:

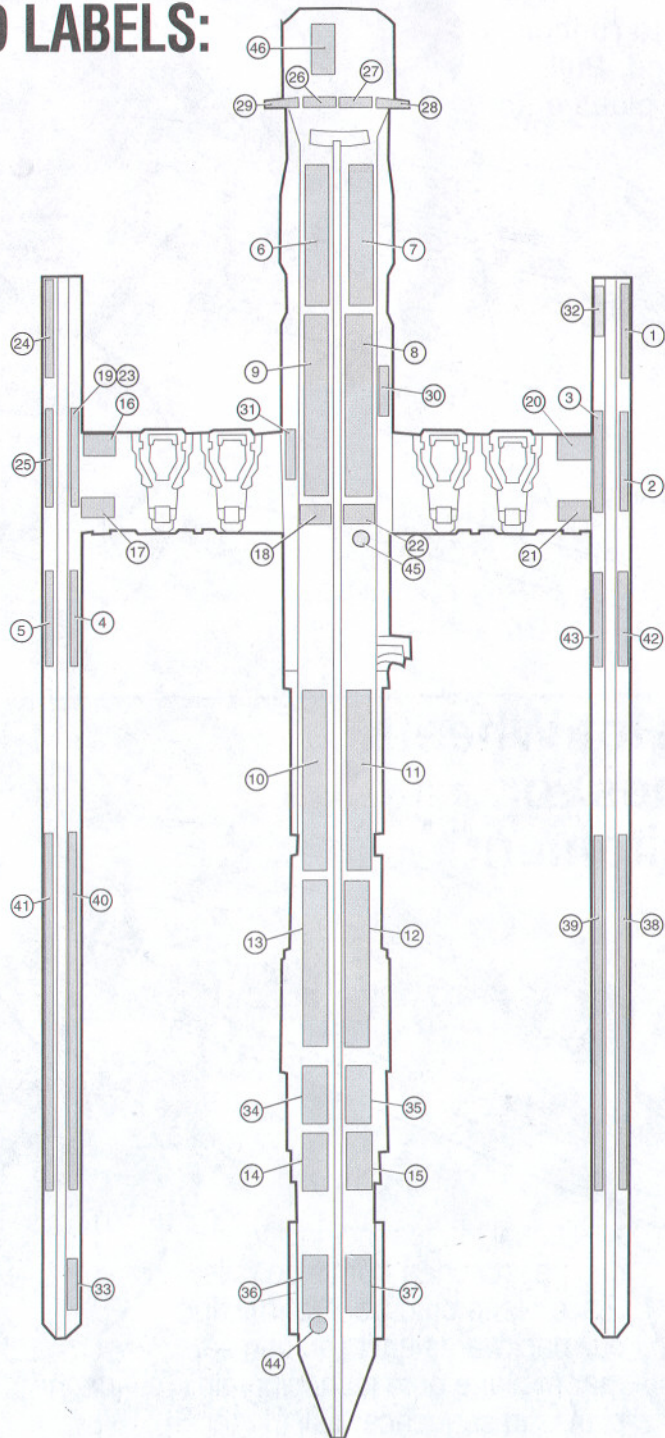

# FLYING TIPS:

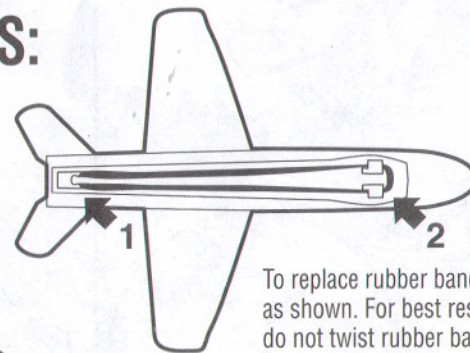

To replace rubber band, attach as shown. For best results, do not twist rubber band.

To fly left, raise up left side of tail.

LEFT

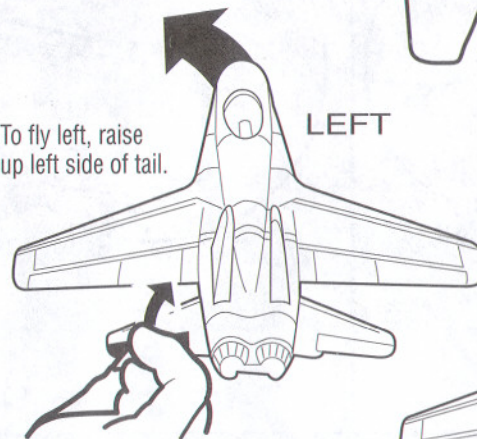

RIGHT

To fly right, raise up right side of tail.

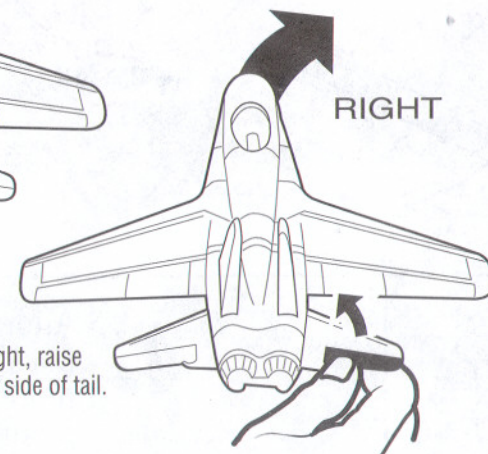

**IMPORTANT CAUTION:** Do not launch at anyone from point blank range.

## 2 YEAR LIMITED WARRANTY

Mattel, Inc. warrants to the original consumer purchaser that this product will be free of defects in material or workmanship for two years (unless otherwise specified in alternate warranties) from the date of purchase. If defective, return the product along with proof of the date of purchase, postage prepaid, to Consumer Adjustment Center, 15930 E. Valley Boulevard, City of Industry, CA 91744 for replacement or refund at our option. This warranty does not cover damage resulting from accident, misuse or abuse. **VALID ONLY IN U.S.A.** This warranty gives you specific legal rights and you may also have other rights which vary from state to state.

Send only the product to the address above. Send all correspondence to Consumer Affairs, Mattel, Inc., 333 Continental Blvd., El Segundo, CA 90245-5012, U.S.A. Or you may phone us toll-free at 1-800-524-TOYS, Monday through Friday: 8:00 a.m.-5:00 p.m. PST (11:00 a.m.-8:00 p.m. EST).

### CONSUMER INFORMATION

**YOU CAN TELL IT'S MATTEL!** CALL us toll-free or write with any comments or questions about our products or service. Monday-Friday, 8:00 a.m.-5:00 p.m. PST; 11:00 a.m.-8:00 p.m. EST. Outside U.S.A., see telephone directory for Mattel listing. Consumer Affairs, Mattel, Inc., 333 Continental Blvd., El Segundo, CA 90245 USA

**1 (800) 524-TOYS**

CONFORMS TO THE SAFETY REQUIREMENTS OF ASTM F963.

-We are dedicated to quality products.