



# *3-in-1 Sports Trainer*

Model Number: 77206



Please keep this instruction sheet for future reference,  
as it contains important information.

Adult assembly is required.

Tool required for assembly and battery installation:  
Phillips screwdriver (not included).

Requires four "D" (LR20) **alkaline** batteries (not included).

**Fisher-Price®**

Discover what's possible™...[www.fisher-price.com](http://www.fisher-price.com)

# **WARNING**

**To prevent injury from balls and moving parts:**

- Keep face, head and hands away from the ball release.
- Use only the balls included.
- Never put other objects in the ball chute.

## Parts



Ball Chute

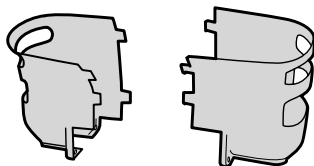

Storage Cages



2 Footballs

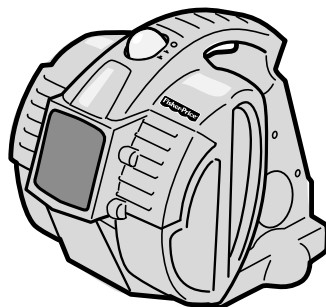

Trainer



2 Hockey Balls



2 Baseballs

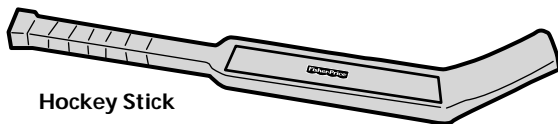

Hockey Stick

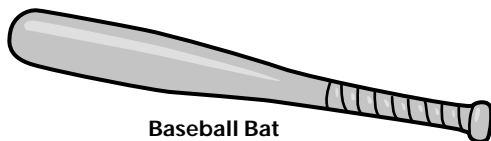

Baseball Bat

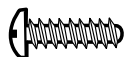

#6 x 1/2" Screw – 4  
Shown Actual Size

Part not shown: Label Sheet

# Battery Installation

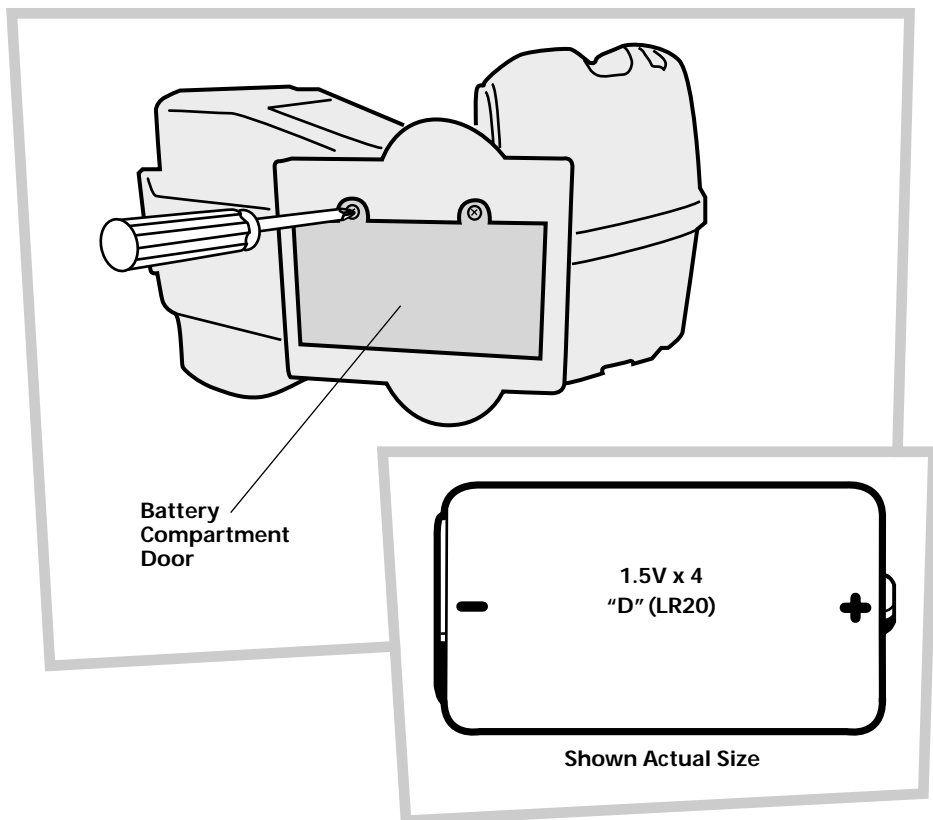

- Locate the battery compartment door on the bottom of trainer.
- Loosen the screws in the battery compartment door with a Phillips screwdriver. Remove the battery compartment door.
- Insert four, "D" (LR20) **alkaline** batteries, as indicated inside the battery compartment.
- Replace the battery compartment door and tighten the screws with a Phillips screwdriver. Do not over-tighten.
- When ball release distance is greatly reduced or if the time between ball releases is much longer, it's time for an adult to change the batteries!

**Hint:** We recommend using **alkaline** batteries for longer battery life.

## ***Battery Tips***

- Do not mix old and new batteries.
- Do not mix different types of batteries: alkaline, standard (carbon-zinc) or rechargeable (nickel-cadmium).
- Remove the batteries during long periods of non-use. Always remove exhausted batteries from the toy. Battery leakage and corrosion can damage this toy. Dispose of batteries safely.
- Do not dispose of batteries in a fire. The batteries may explode or leak.
- Never short circuit the battery terminals.
- Non-rechargeable batteries are not to be recharged.
- Only batteries of the same or equivalent type as recommended in the "Battery Installation" instructions are to be used.
- If removable rechargeable batteries are used, they are only to be charged under adult supervision.
- Rechargeable batteries are to be removed from the toy before they are charged.
- If you use a battery charger, it should be examined regularly for damage to the cord, plug, enclosure and other parts. Do not use a damaged battery charger until it has been properly repaired.

# One-Time Assembly

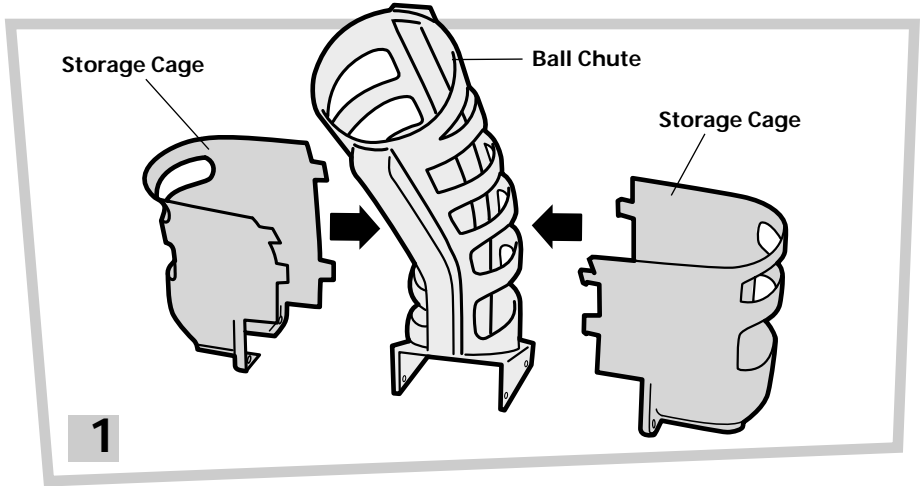

- Insert and **"snap"** the tabs on each storage cage into the slots in the ball chute, as shown.

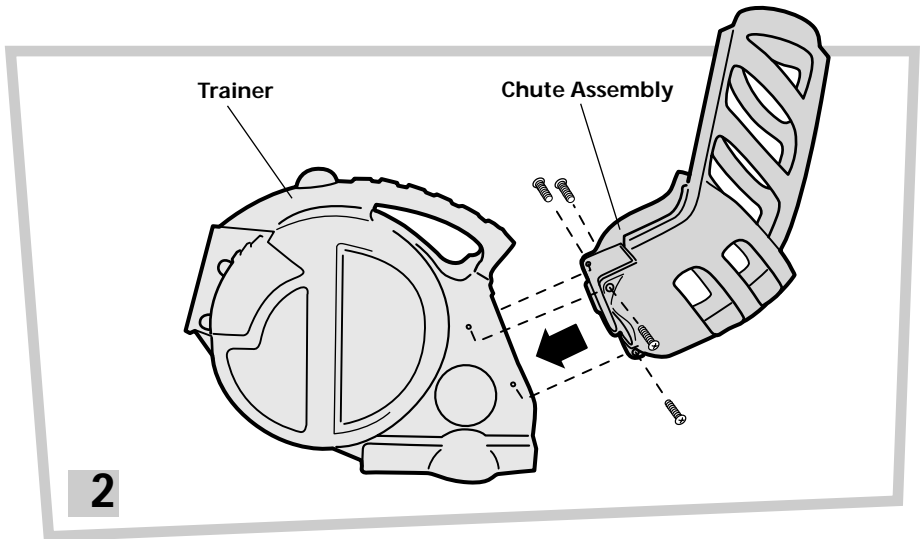

- Fit the chute assembly to the side of the trainer, as shown.
- Insert four screws through the chute assembly and into the trainer. Tighten the screws with a Phillips screwdriver. Do not over-tighten.

# Label Decoration

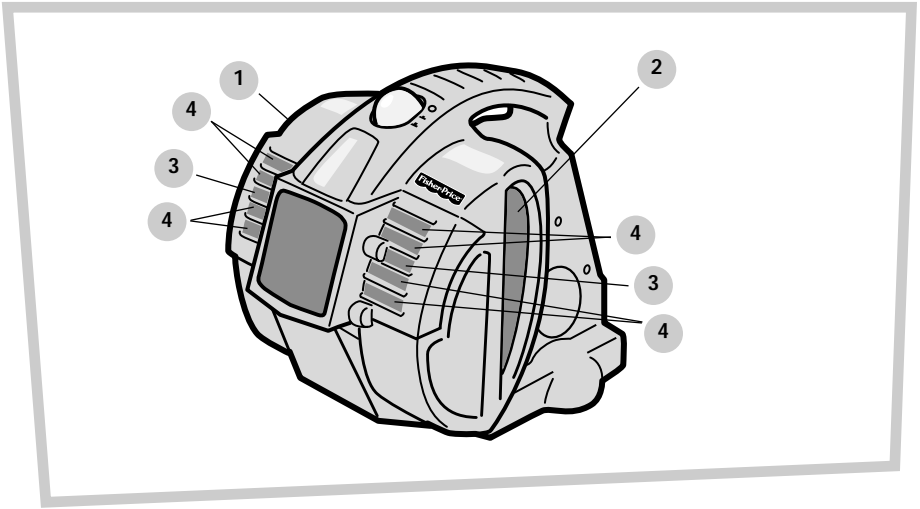





**Proper label application will help keep labels looking their best! When applying labels, keep the following guidelines in mind:**

- Wash hands before applying labels.
- Before applying labels, wipe the surface of the toy with a clean, dry cloth to remove dust or oils.
- For best results, avoid repositioning a label once it has been applied.

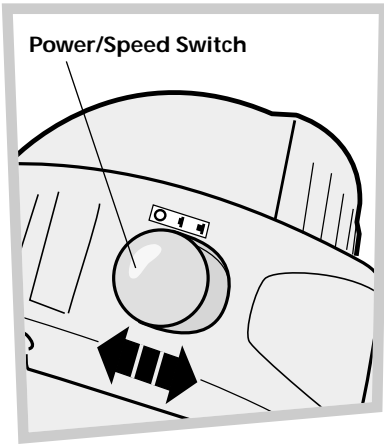
**One-time assembly is now complete.**

# Three Sport Training for "Rookies" and "Pros"



- The trainer has a three position switch: Off , Low  and High . Set to high or low as directed on pages 8 through 10.

## Loading the Trainer

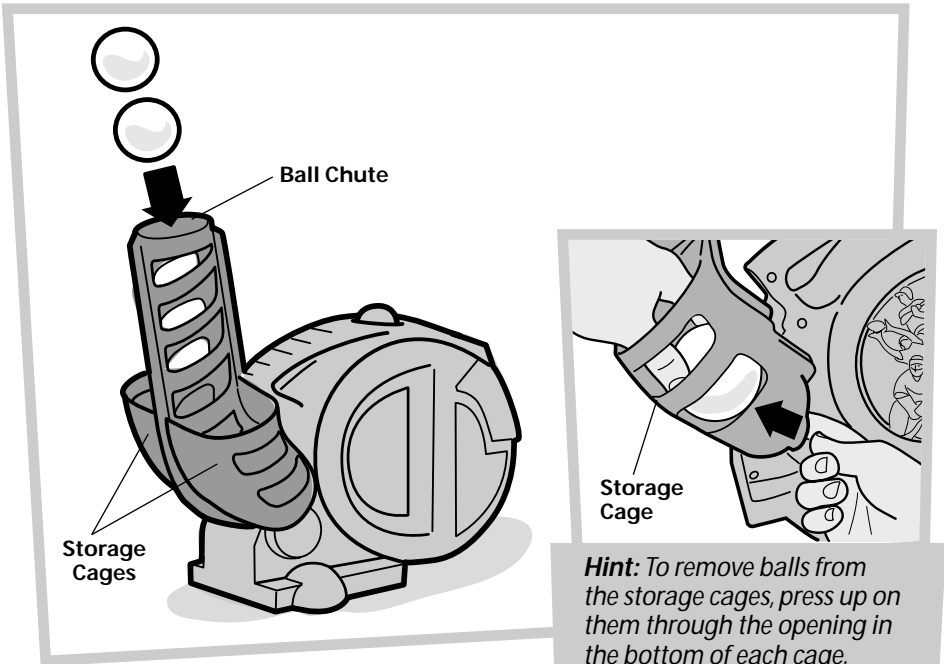

- Place balls in the ball chute as shown.
- Store additional balls in the storage cages on either side of the ball chute.

# Baseball Training



- Load the baseballs into the ball chute.

**Hint:** The hockey balls will also work for baseball training.

- Set the power/speed switch to low speed  for beginners, high speed  for more experienced athletes.
- Stand back at least 12 feet from the trainer.

**Hint:** Distance will vary depending on speed setting and your child's comfort.

- The trainer releases the baseballs about ten seconds apart. Try hitting it with the baseball bat or catching it!



# Hockey Training

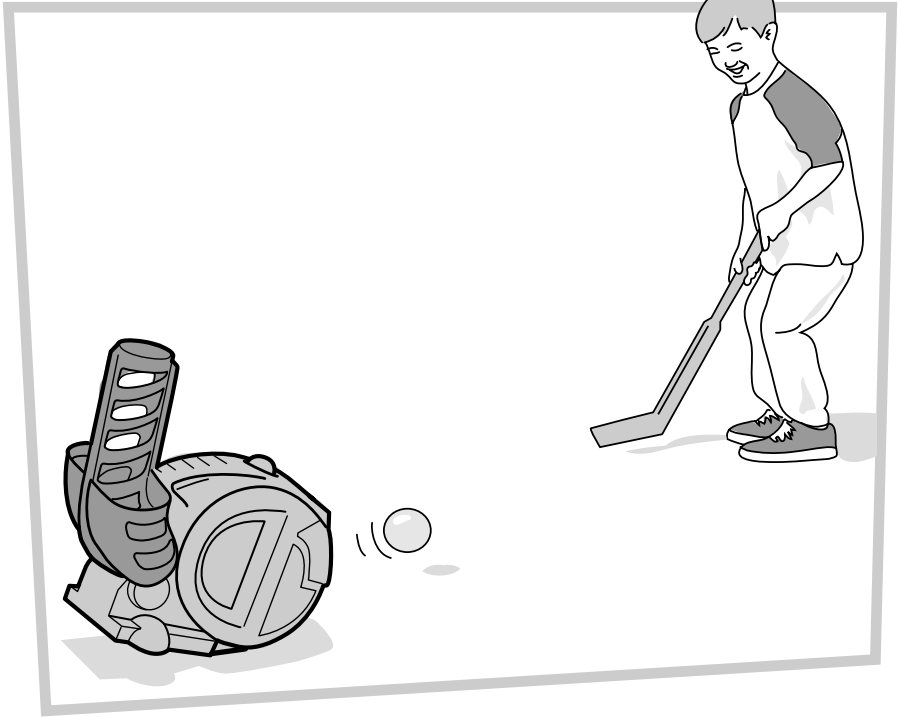

- Tilt the trainer forward to release hockey balls at ground level.
- Load the hockey balls into the ball chute.

**Hint:** The baseballs will also work for hockey training.

- Set the power/speed switch to low speed **■** for beginners, high speed **■** for more experienced athletes.
- Stand back at least 12 feet from the trainer.

**Hint:** Distance will vary depending on speed setting and your child's comfort.

- The trainer releases the hockey balls about ten seconds apart. Make the save or receive the pass!

# Football Training

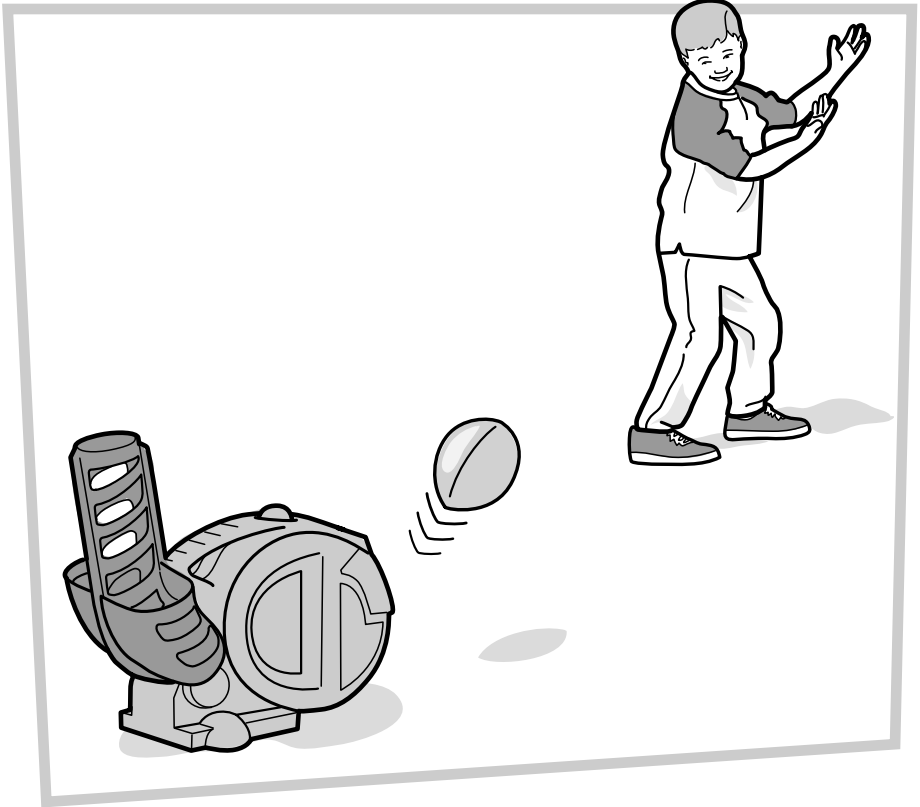

- Load the footballs into the ball chute.
- Set the power/speed switch to low speed  for beginners, high speed  for more experienced athletes.
- Stand back at least 12 feet from the trainer.

**Hint:** Distance will vary depending on speed setting and your child's comfort.

- The trainer releases the footballs about ten seconds apart. Catch the ball and run for a touchdown!

## ***Important Notes***

- Keep balls dry. If balls become wet, release distance will be reduced.
- Use only the balls that came with this toy. Do not use any other balls.
- If the trainer becomes jammed (motor is running and the balls aren't releasing), switch the trainer off and tip it upside down to dump out all of the balls. Running the trainer when it is jammed may permanently damage the toy.

## ***Care***

- Do not leave this toy outside when not in use.
- Wipe with a clean cloth dampened with a mild soap and water solution.
- Do not immerse this toy.

# *Consumer Information*

## **Questions? We'd like to hear from you!**

Call Fisher-Price® Consumer Relations, toll-free at **1-800-432-KIDS**, 8 AM - 6 PM EST Monday through Friday. Hearing-impaired consumers using TTY/TDD equipment, please call 1-800-382-7470.

Or, write to:  
Fisher-Price® Consumer Relations  
636 Girard Avenue  
East Aurora, New York 14052

For other countries, outside the United States:

**Canada:** call **1-800-567-7724**, or write to: Mattel Canada Inc., 6155 Freemont Blvd., Mississauga, Ontario L5R 3W2.

**Great Britain:** telephone 01628 500302.

**Australia:** Mattel Australia Pty. Ltd., 658 Church Street, Locked Bag #870, Richmond, Victoria 3121 Australia. Consumer Advisory Service 1300 135 312.

**New Zealand:** 16-18 William Pickering Drive, Albany 1331, Auckland.

Fisher-Price, Inc., a subsidiary of Mattel, Inc., East Aurora, NY 14052 U.S.A.

©2002 Mattel, Inc. All Rights Reserved. ® and ™ designate U.S. trademarks of Mattel, Inc.