

Fisher-Price®

Rockin' Roadsters™

D R A G S T R I P



Product Number: 77839

Please keep this instruction sheet for future reference,
as it contains important information.

Requires three "AA" batteries (included).

Adult assembly is required for battery replacement.

Tool required for battery replacement: Phillips screwdriver (not included).

Discover what's possible™... www.fisher-price.com

Battery Replacement

For best performance, we recommend replacing the batteries that came with this toy with three, new alkaline "AA" (LR6) batteries.

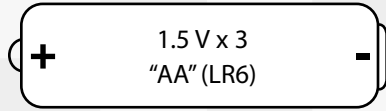

Shown Actual Size

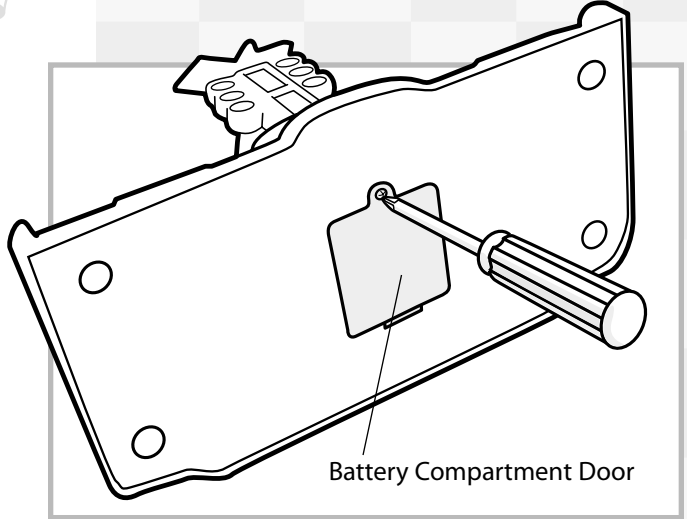

- Locate the battery compartment on the bottom of the toy.
- Loosen the screw in the battery compartment door with a Phillips screwdriver. Remove the battery compartment door.
- Insert three "AA" (LR6) **alkaline** batteries, as indicated inside the battery compartment.

Hint: We recommend using **alkaline** batteries for longer life.

- Replace the battery compartment door and tighten the screw with a Phillips screwdriver. Do not over-tighten.
- When sounds or lights from this toy become faint or stop, it's time for an adult to change the batteries!

Battery Tips



- Do not mix old and new batteries.
- Do not mix different types of batteries: alkaline, standard (carbon-zinc) or rechargeable (nickel-cadmium).
- Remove the batteries during long periods of non-use. Always remove exhausted batteries from the toy. Battery leakage and corrosion can damage this toy. Dispose of batteries safely.
- Do not dispose of batteries in a fire. The batteries may explode or leak.
- Never short circuit the battery terminals.
- Non-rechargeable batteries are not to be recharged.
- Only batteries of the same or equivalent type as recommended in the "Battery Replacement" instructions are to be used.
- If removable rechargeable batteries are used, they are only to be charged under adult supervision.
- Rechargeable batteries are to be removed from the toy before they are charged.
- If you use a battery charger, it should be examined regularly for damage to the cord, plug, enclosure and other parts. Do not use a damaged battery charger until it has been properly repaired.

Power Switch

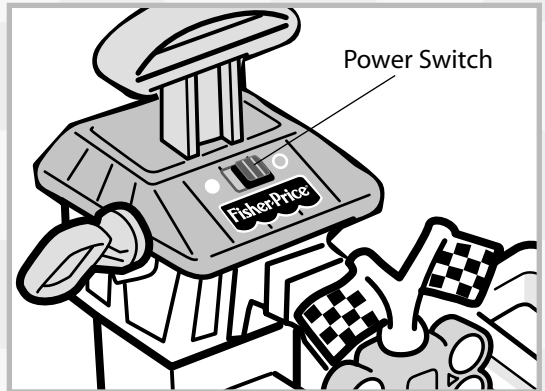

- Locate the power switch on top of the toy.
- Slide the switch to the ● position to turn the toy on.
- Slide the switch to off ○ position when you are finished with the toy.

Revved Up Racing Action!

Load The Cars

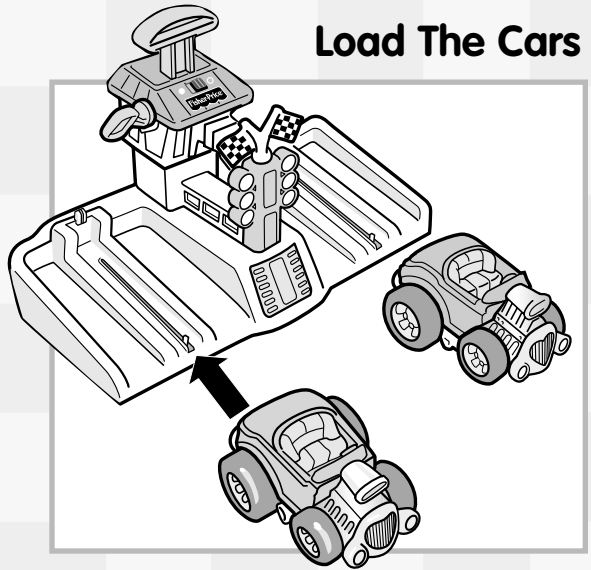

- Place one of the cars in front of the drag strip, as shown.

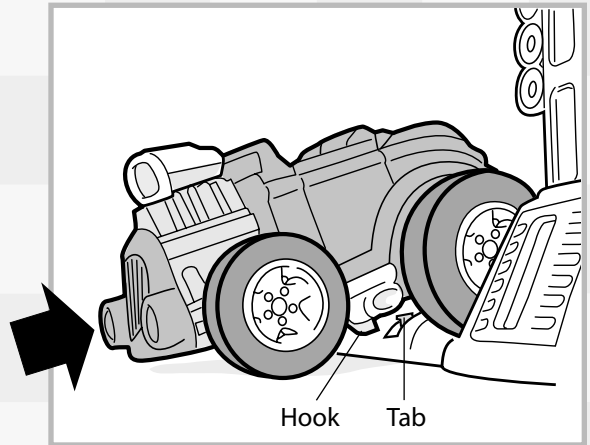

- While pressing down lightly, roll the car backwards up to the top of the ramp until it "clicks" in place.
- The hook on the bottom of the car should catch the tab in the slot.

Hint: You will feel some resistance as you load the car.

- Repeat this procedure to load the other car.

Revvin' to Go

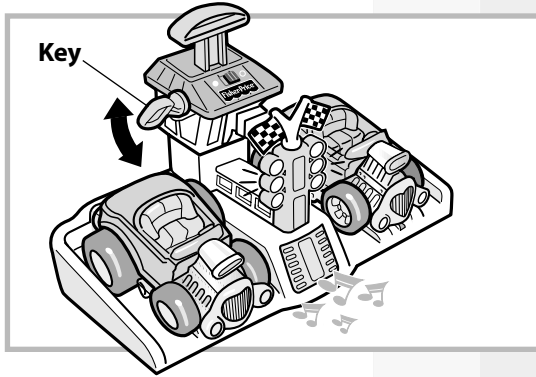

- Turn the key one way to hear a rockin' tune and see the lights flash.
- Turn the key the other way to hear racing sound effects and see the lights flash.

⚠ CAUTION

- Do not launch cars at close range.
- Use only Rockin' Roadsters™ cars with this toy.
- Do not launch cars at people or animals.

Go!

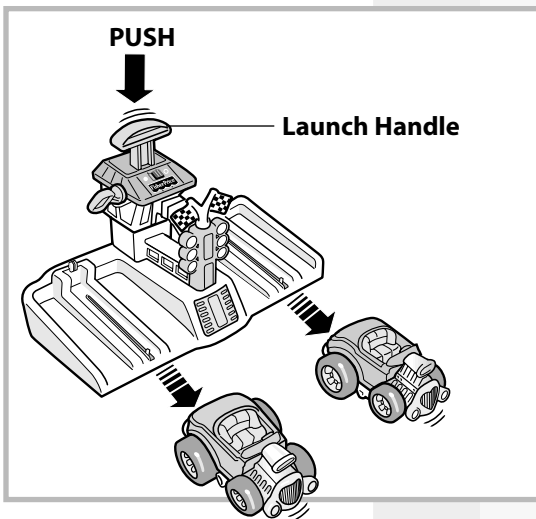

- Push the launch handle to release the cars and start the drag race.

Care

- Wipe this toy with a clean cloth dampened with a mild soap and water solution. Do not immerse this toy.
- This toy has no consumer serviceable parts. Do not take this toy apart.

FCC Note (United States Only)



Consumer Information

Note: This equipment has been tested and found to comply with the limits for a Class B digital device, pursuant to Part 15 of the FCC Rules. These limits are designed to provide reasonable protection against harmful interference in a residential installation. This equipment generates, uses and can radiate radio frequency energy and, if not installed and used in accordance with the instructions, may cause harmful interference to radio communications. However, there is no guarantee that interference will not occur in a particular installation. If this equipment does cause harmful interference to radio or television reception, which can be determined by turning the equipment off and on, the user is encouraged to try to correct the interference by one or more of the following measures:

- Reorient or relocate the receiving antenna.
- Increase the separation between the equipment and receiver.
- Consult the dealer or an experienced radio/TV technician for help.

CAUTION: Changes or modifications not expressly approved by the manufacturer responsible for compliance could void the user's authority to operate the equipment.

Questions? We'd like to hear from you!

Call Fisher-Price® Consumer Relations, toll-free at **1-800-432-KIDS**, 8 AM - 6 PM EST Monday through Friday. Hearing-impaired consumers using TTY/TDD equipment, please call 1-800-382-7470. Or, write to:

Fisher-Price® Consumer Relations
636 Girard Avenue
East Aurora, New York 14052

For other countries, outside the United States:

Canada: call **1-800-567-7724**, or write to: Mattel Canada Inc, 6155 Freemont Blvd., Mississauga, Ontario L5R 3W2.

Great Britain: telephone 01628 500302.

Australia: Mattel Australia Pty. Ltd., 658 Church Street, Locked Bag #870, Richmond, Victoria 3121 Australia.

Consumer Advisory Service 1300 135 312.

New Zealand: 16-18 William Pickering Drive, Albany 1331, Auckland.

Fisher-Price, Inc., subsidiary of Mattel, Inc.,
East Aurora, NY 14052 U.S.A.

©2002 Mattel, Inc. All Rights Reserved.

® and ™ designate U.S. trademarks of Mattel, Inc.