

Wizard's Tower

Model
78331



imaginext SYSTEM™

Fisher-Price®

www.fisher-price.com

Welcome to the Imaginext™ System

The Imaginext™ system lets your child's imagination come alive. With Quick-Snap panels™, kids can build different structures in lots of different ways. Use some of the parts or all of them!

Preschool children will enjoy using all parts of this toy to build structures of their own creation. At first they will need parental assistance to build the structure on the front cover. It may be easier to use our step-by-step instructions and give your preschooler only the parts that will be assembled in each step. The more your child plays with this toy, and development and skill increases, the less assistance your child will need!



Each sold separately and subject to availability.

Please keep this instruction sheet for future reference, as it contains important information.

Requires two "AAA" (LR03) alkaline batteries (not included).

Adult assembly is required for battery installation.

Tool needed for battery installation: Phillips screwdriver (not included). For children 4-10 years.

Building System Tips

Here are a few basic tips of the Imaginext System!

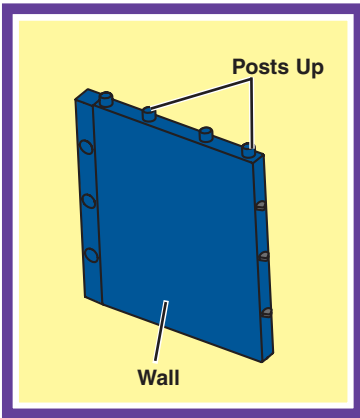

Posts Up

Posts on walls should always face up.

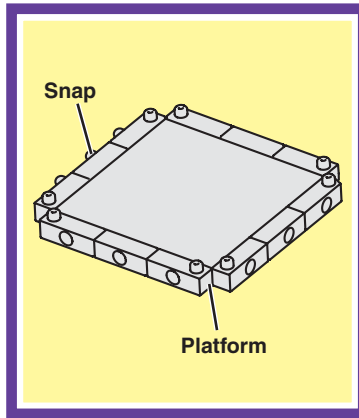

Locate Snaps

Note the locations of the snaps on platforms.

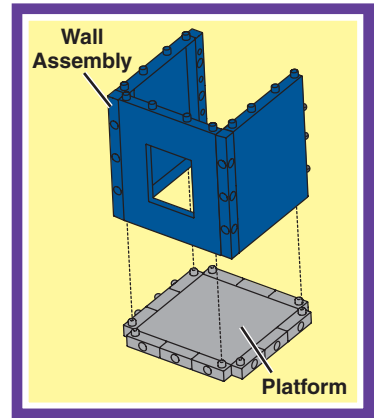

Walls Before Platforms

Assemble walls before attaching to a platform.

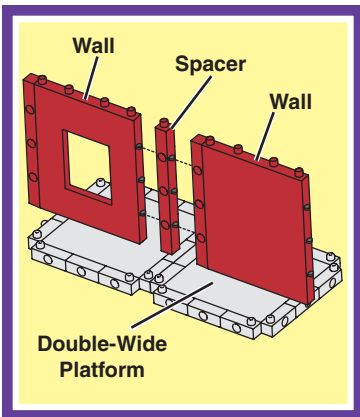

Use Spacers Between Walls that Connect to Platforms

Walls joined side-by-side may require a spacer between them when connected to two single platforms, or one double-wide platform.

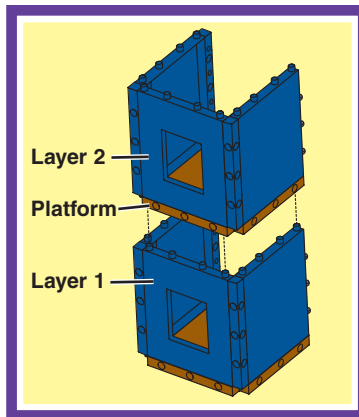

Build Up

Build the bottom layer first, then build additional layers. Use a platform between each layer of your design.

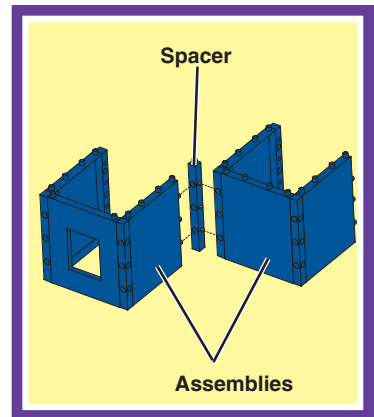

Spacers Between Assemblies

Use a spacer to connect assemblies when needed.

Battery Installation

- Locate the battery compartment door on the sounds and lights box.
- Loosen the screw in the battery compartment door with a Phillips screwdriver. Remove the battery compartment door.
- Insert two, "AAA" (LR03) **alkaline** batteries, as indicated inside the battery compartment.

Hint: We recommend using **alkaline** batteries for longer battery life.

- Replace the battery compartment door and tighten the screw with a Phillips screwdriver. Do not over-tighten.
- When sounds or lights from this toy become faint or stop, it's time for an adult to change the batteries!

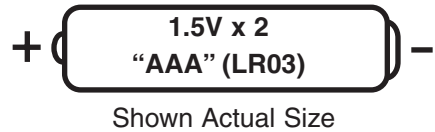
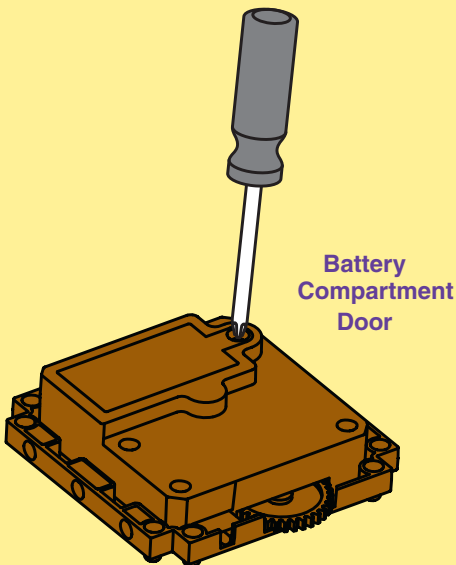

- Do not mix old and new batteries.
- Do not mix different types of batteries: alkaline, standard (carbon-zinc) or rechargeable (nickel-cadmium).
- Remove the batteries during long periods of non-use. Always remove exhausted batteries from the toy. Battery leakage and corrosion can damage this toy. Dispose of batteries safely.
- Do not dispose of batteries in a fire. The batteries may explode or leak.
- Never short circuit the battery terminals.
- Non-rechargeable batteries are not to be recharged.
- Only batteries of the same or equivalent type as recommended in the "Battery Installation" instructions are to be used.
- If removable rechargeable batteries are used, they are only to be charged under adult supervision.
- Rechargeable batteries are to be removed from the toy before they are charged.
- If you use a battery charger, it should be examined regularly for damage to the cord, plug, enclosure and other parts. Do not use a damaged battery charger until it has been properly repaired.

Let's Build It!

1.

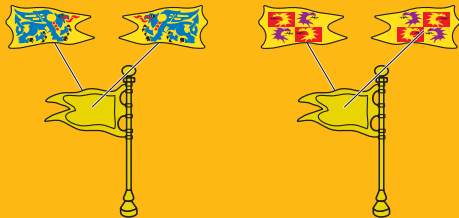

- **Proper label application will help to keep the labels looking their best! When applying labels, keep the following guidelines in mind:**
- Wash your hands before applying the labels.
- Before applying the labels, wipe the surfaces of this toy with a clean, dry cloth to remove any dust or oils.
- Place the labels exactly as shown in the illustrations.
- For best results, avoid repositioning a label once it has been applied.

2.

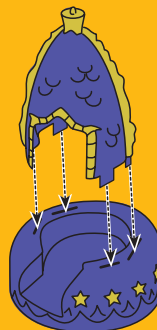

3.

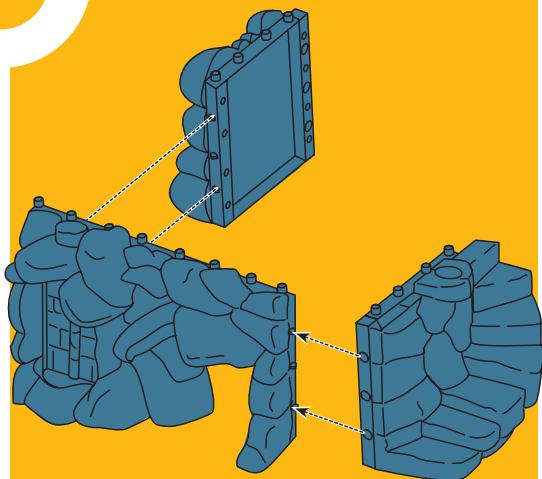

4.

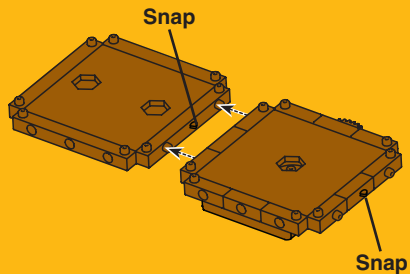

Let's Build It!

9.

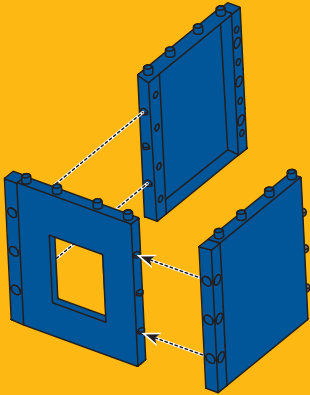

10.

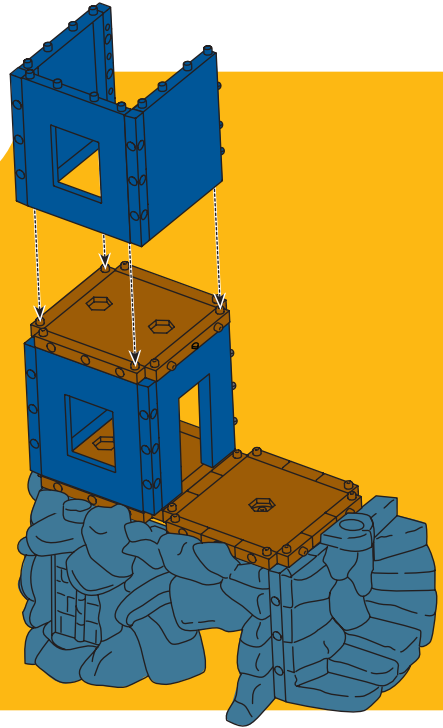

11.

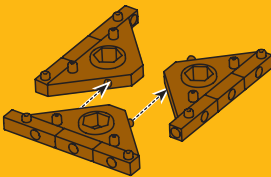

12.

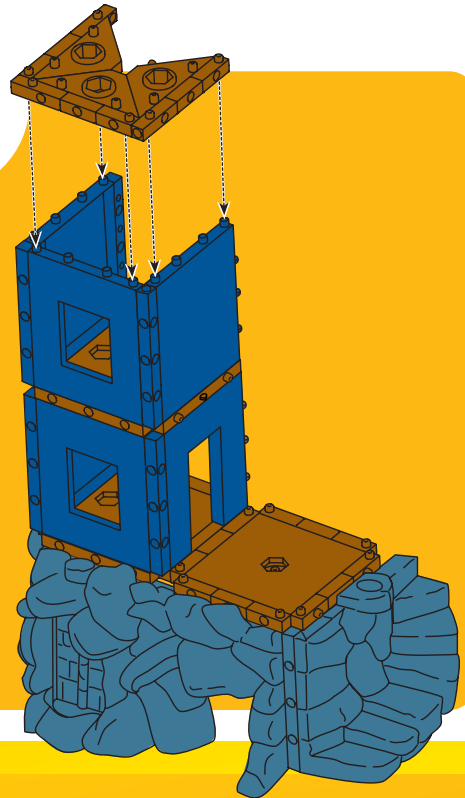

Let's Build It!

13.

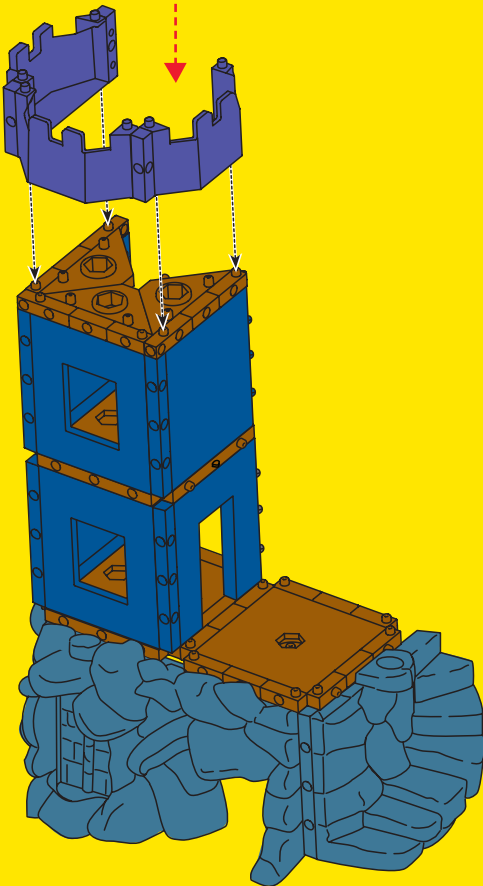
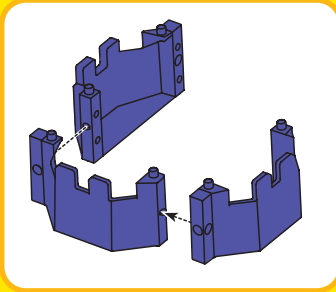

14.

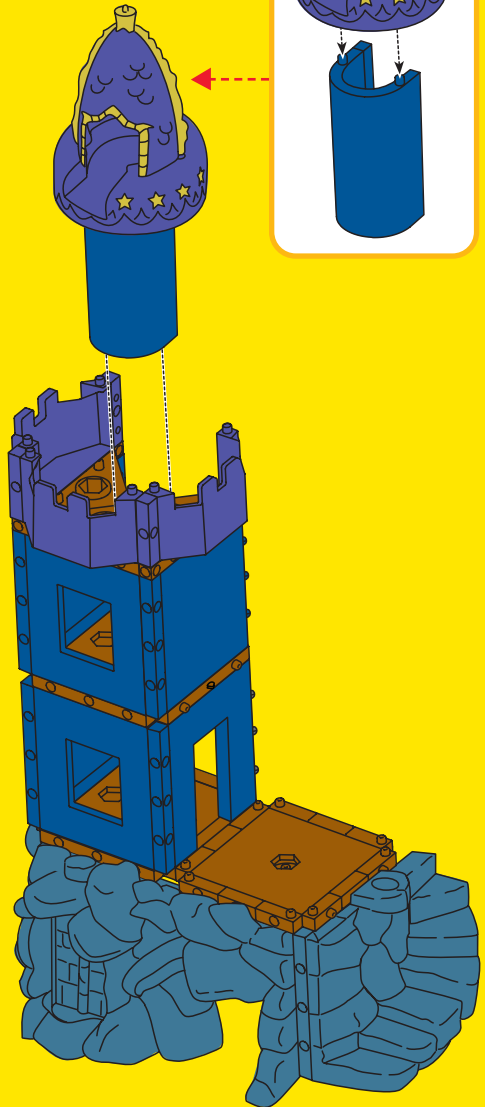
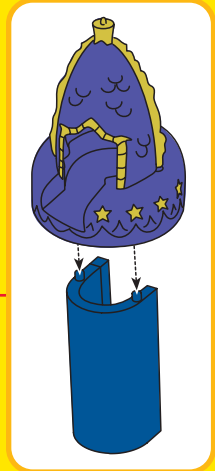

Let's Build It!

17.

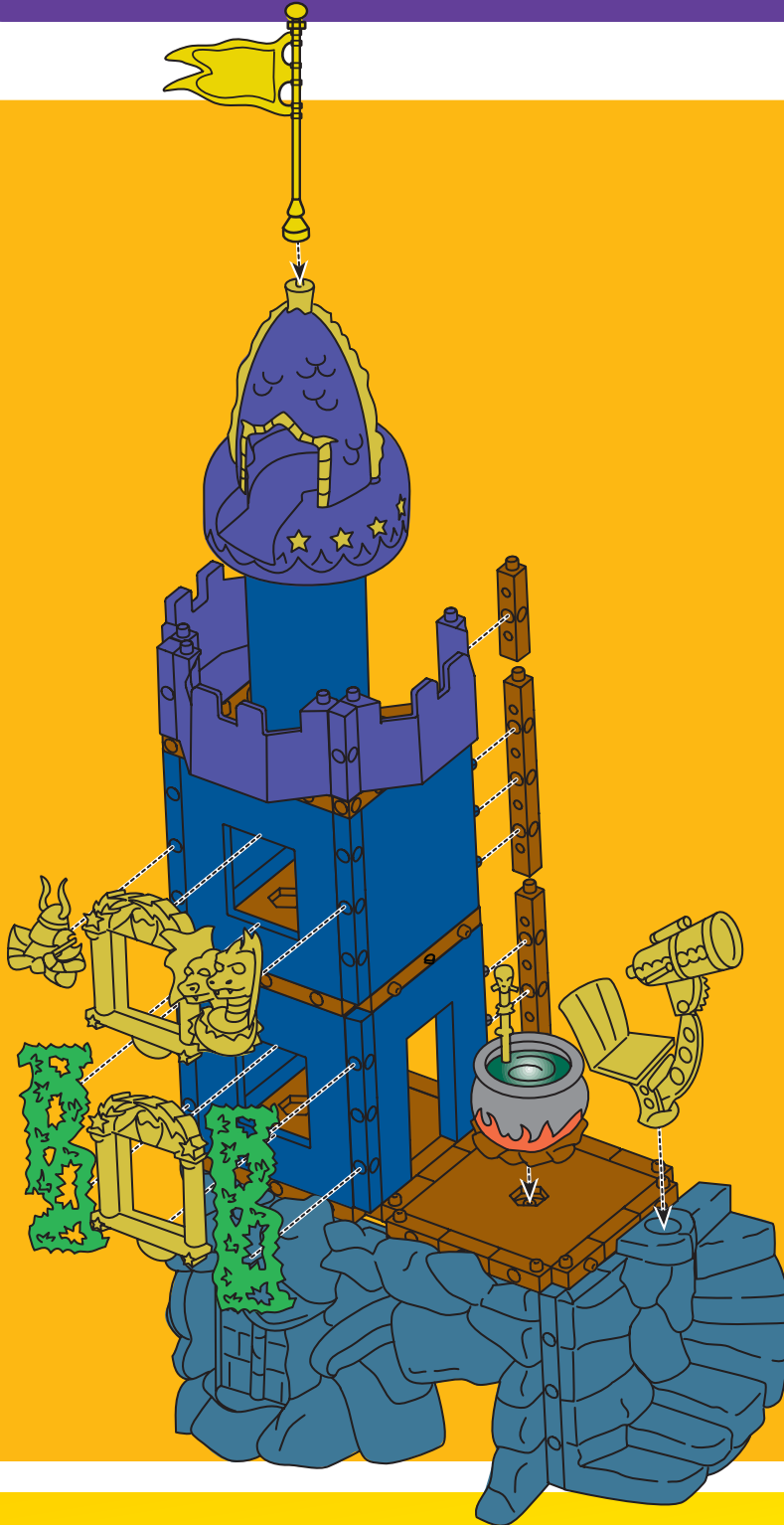

Imagine... So Many Ways To Build!

With so many ways to build your playset, you can create a new adventure every time you play!



Warning and Caution

WARNING

Warning – Choking Hazard Not recommended for children under 3 years because it contains small parts that can be swallowed.

CAUTION

- Do not launch the projectile at close range.
- Only use the projectile supplied with this toy.
- Do not fire at people or animals.

Care

Wipe the toy with a clean cloth dampened with a mild soap and water solution.
Do not immerse the toy.

FCC Note (United States Only)

Note: This equipment has been tested and found to comply with the limits for a Class B digital device, pursuant to Part 15 of the FCC Rules. These limits are designed to provide reasonable protection against harmful interference in a residential installation. This equipment generates, uses and can radiate radio frequency energy and, if not installed and used in accordance with the instructions, may cause harmful interference to radio communications. However, there is no guarantee that interference will not occur in a particular installation. If this equipment does cause harmful interference to radio or television reception, which can be determined by turning the equipment off and on, the user is encouraged to try to correct the interference by one or more of the following measures:

- Reorient or relocate the receiving antenna.
- Increase the separation between the equipment and receiver.
- Consult the dealer or an experienced radio/TV technician for help.

Note: Changes or modifications not expressly approved by the manufacturer responsible for compliance could void the user's authority to operate the equipment.



imaginext SYSTEM™

Questions? We'd like to hear from you!

Call Fisher-Price® Consumer Relations, toll-free at **1-800-432-5437**, 8 AM - 6 PM EST Monday through Friday. Hearing-impaired consumers using TTY/TDD equipment, please call 1-800-382-7470. Or, write to:
Fisher-Price® Consumer Relations, 636 Girard Avenue, East Aurora, New York 14052. U.S.A.

For other countries outside the United States: **Canada:** call **1-800-567-7724**, or write to: Mattel Canada Inc., 6155 Freemont Blvd., Mississauga, Ontario L5R 3W2. **Great Britain:** telephone **01628 500302**.
Australia: Mattel Australia Pty. Ltd., 658 Church Street, Locked Bag #870, Richmond, Victoria 3121 Australia.
Consumer Advisory Service 1300 135 312. **New Zealand:** 16-18 William Pickering Drive, Albany 1331, Auckland.