



Please keep this instruction sheet for future reference,
as it contains important information.

Requires three "AA" batteries (included).

Adult assembly is required for battery replacement.

Tool required for battery replacement:
Phillips screwdriver (not included).



www.fisher-price.com

Rollin' Rumblin' Dump Truck™

Battery Replacement

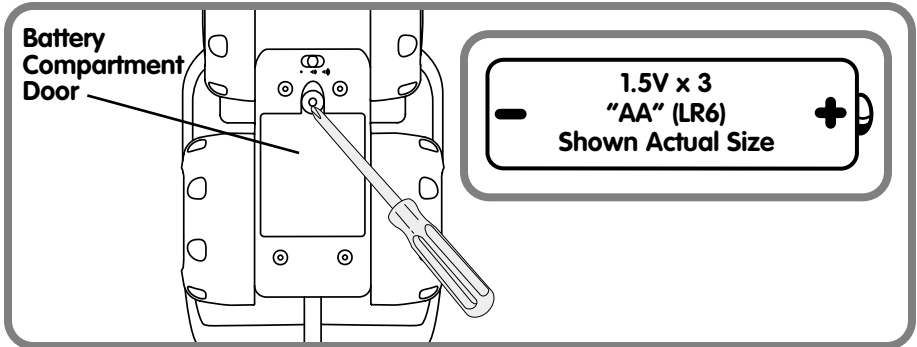

For best results, we recommend replacing the batteries that came with this toy with three, new "AA" (LR6) alkaline batteries.

- Locate the battery compartment on the bottom of the toy.
- Loosen the screw in the battery compartment door with a Phillips screwdriver. Remove the battery compartment door. Throw the exhausted batteries away.
- Insert three, new "AA" (LR6) **alkaline** batteries, as indicated inside the battery compartment.

Hint: We recommend using **alkaline** batteries for longer battery life.

- Replace the battery compartment door and tighten the screw with a Phillips screwdriver. Do not over-tighten.
- When sounds from this toy become faint or stop, it's time for an adult to change the batteries!

Battery Safety Information

Batteries may leak fluids that can cause a chemical burn injury or ruin your toy. To avoid battery leakage:

- Do not mix old and new batteries or batteries of different types: alkaline, standard (carbon-zinc) or rechargeable (nickel-cadmium).
- Insert batteries as indicated on the battery compartment door.
- Remove batteries during long periods of non-use. Always remove exhausted batteries from the toy. Dispose of batteries safely. Do not dispose of batteries in a fire. The batteries may explode or leak.
- Never short-circuit the battery terminals.
- Use only batteries of the same or equivalent type, as recommended.
- Do not charge non-rechargeable batteries.
- Remove rechargeable batteries from the toy before charging.
- If removable, rechargeable batteries are used, they are only to be charged under adult supervision.

Fun Blocks and Sounds!

Push the truck to hear music and fun sound effects!



Fit blocks into the wheels.

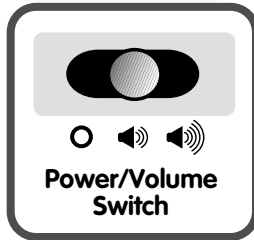

Power/Volume Switch

- Locate the power/volume switch on the bottom of the toy. Slide the switch to any of three positions: off ○; on with low volume 🗣️; or on with high volume 🗣️🗣️.

Hint: If your child is not actively playing with this toy, it turns off automatically (sleep mode).

- When your child is finished playing with this toy, slide the power/volume switch to the off position ○.

Care

- Wipe the toy with a clean cloth dampened with a mild soap and water solution.
- Do not immerse the toy.

Consumer Information

Questions? We'd like to hear from you!

Call Fisher-Price® Consumer Relations, toll-free at **1-800-432-5437**, 8 AM - 6 PM EST Monday through Friday. Hearing-impaired consumers using TTY/TDD equipment, please call 1-800-382-7470. Or, write to: Fisher-Price® Consumer Relations, 636 Girard Avenue, East Aurora, New York 14052.

FCC Note (United States Only)

Note: This equipment has been tested and found to comply with the limits for a Class B digital device, pursuant to Part 15 of the FCC Rules. These limits are designed to provide reasonable protection against harmful interference in a residential installation. This equipment generates, uses and can radiate radio frequency energy and, if not installed and used in accordance with the instructions, may cause harmful interference to radio communications. However, there is no guarantee that interference will not occur in a particular installation. If this equipment does cause harmful interference to radio or television reception, which can be determined by turning the equipment off and on, the user is encouraged to try to correct the interference by one or more of the following measures:

- Reorient or relocate the receiving antenna.
- Increase the separation between the equipment and receiver.
- Consult the dealer or an experienced radio/TV technician for help.

Note: Changes or modifications not expressly approved by the manufacturer responsible for compliance could void the user's authority to operate the equipment.

For countries outside the United States:

CANADA Questions? 1-800-567-7724. Mattel Canada Inc., 6155 Freemont Blvd., Mississauga, Ontario L5R 3W2.

GREAT BRITAIN Mattel UK Ltd, Vanwall Business Park, Maidenhead SL6 4UB. Helpline: 01628 500302.

AUSTRALIA Mattel Australia Pty. Ltd., 658 Church Street, Locked Bag #870, Richmond, Victoria 3121 Australia. Consumer Advisory Service 1300 135 312.

NEW ZEALAND 16-18 William Pickering Drive, Albany 1331, Auckland.

ASIA Mattel East Asia Ltd, Room 1106, South Tower, World Finance Centre, Harbour City, Tsimshatsui, HK, China.