



# Consumer Information



## CONSUMER ASSISTANCE

1-800-432-5437 (US & Canada)  
1300 135 312 (Australia)

## service.fisher-price.com

---

Fisher-Price, Inc., 636 Girard Avenue, East Aurora, NY 14052.  
Hearing-impaired consumers: 1-800-382-7470.

---

**Outside the United States:**

Canada: Mattel Canada Inc., 6155 Fremont Blvd.,  
Mississauga, Ontario L5R 3W2; [www.service.mattel.com](http://www.service.mattel.com).

Great Britain: Mattel UK Ltd, Vanwall Business Park,  
Maidenhead SL6 4UB. Helpline: 01628 500303.  
[www.service.mattel.com/uk](http://www.service.mattel.com/uk)

Mattel Europa B.V., Gondel 1, 1186 MJ Amstelveen, Nederland.

Australia: Mattel Australia Pty. Ltd., 658 Church Street,  
Locked Bag #870, Richmond, Victoria 3121 Australia.

New Zealand: 16-18 William Pickering Drive,  
Albany 1331, Auckland.

### ICES-003

This Class B digital apparatus complies with Canadian ICES-003. Operation is subject to the following two conditions: (1) this device may not cause harmful interference and (2) this device must accept any interference received, including interference that may cause undesired operation.

### NMB-003

Cet appareil numérique de la classe B est conforme à la norme NMB-003 du Canada. L'utilisation de ce dispositif est autorisée seulement aux conditions suivantes : (1) il ne doit pas produire de brouillage et (2) l'utilisateur du dispositif doit être prêt à accepter tout brouillage radioélectrique reçu, même si ce brouillage est susceptible de compromettre le fonctionnement du dispositif.



- Protect the environment by not disposing of this product with household waste (2002/96/EC). Check your local authority for recycling advice and facilities.

### FCC Statement (United States Only)

This equipment has been tested and found to comply with the limits for a Class B digital device, pursuant to Part 15 of the FCC Rules. These limits are designed to provide reasonable protection against harmful interference in a residential installation. This equipment generates, uses and can radiate radio frequency energy and, if not installed and used in accordance with the instructions, may cause harmful interference to radio communications. However, there is no guarantee that interference will not occur in a particular installation. If this equipment does cause harmful interference to radio or television reception, which can be determined by turning the equipment off and on, the user is encouraged to try to correct the interference by one or more of the following measures:

- Reorient or relocate the receiving antenna.
- Increase the separation between the equipment and receiver.
- Consult the dealer or an experienced radio/TV technician for help.

**Note:** Changes or modifications not expressly approved by the manufacturer responsible for compliance could void the user's authority to operate the equipment.

This device complies with Part 15 of the FCC Rules. Operation is subject to the following two conditions: (1) This device may not cause harmful interference and (2) this device must accept any interference received, including interference that may cause undesired operation.

# Assembled Parts



## CAUTION

This package contains small parts. For adult assembly only.

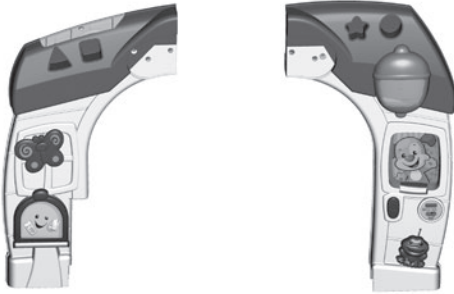

**2 Walls  
(Left and Right)**



**Floor**



**Door**



**2 Bases  
(Left and Right)**



**House Number**



**Chimney**



**Handle**



**Shape Sorter Cabinet**



**#6 x 3/4" (1,9 cm) Screws – 19**

**SHOWN ACTUAL SIZE**

Tighten and loosen screws with a Phillips screwdriver. Do not over-tighten the screws.

# Assembly

Walls

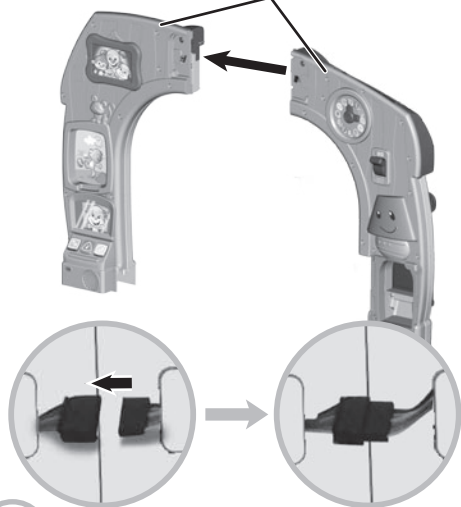

1

- Fit the walls together.

**IMPORTANT!** Fit the smaller connector into the larger connector. The connectors are designed to fit one way. Do not force the connectors together. If they do not seem to fit together, check to be sure that the wires are not twisted and try again.

House Number

Handle

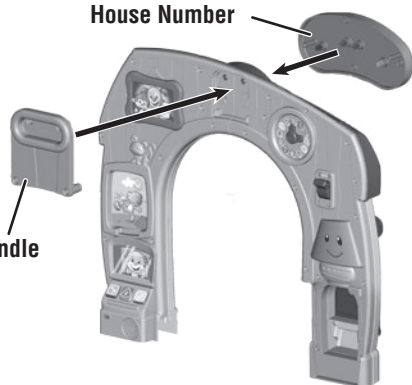

2

- Fit the house number and handle to the wall assembly.



3

- Insert four screws into the handle and tighten.



4

- Insert two screws into the wall assembly and tighten.

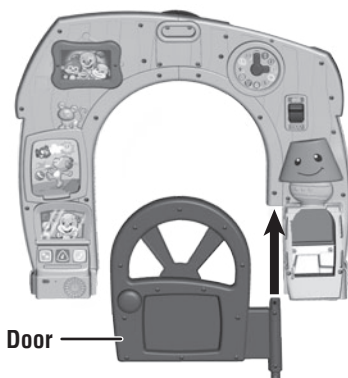

Door

5

- Fit the door upper pin into the hinge on the
- 4

# Assembly

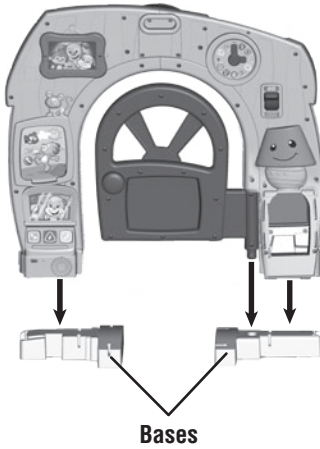

6

Bases

- Position the bases on a flat surface with the wide ends facing each other.
- Fit the wall assembly and door lower peg into the slots and hole in the bases.

*Hint: The wall assembly with door is designed to fit the bases one way. If it does not seem to fit, reverse the bases and make sure the base with a hole is on the same side as the door peg.*

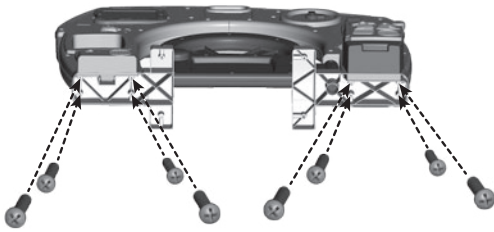

7

BOTTOM VIEW

- Carefully turn the assembly on its side. Insert eight screws into the bases and tighten.



8

- Turn the assembly upright.
- Fit the floor to the bases.

*Hint: The floor is designed to fit the bases one way. If it does not seem to fit, turn the floor around and try again.*

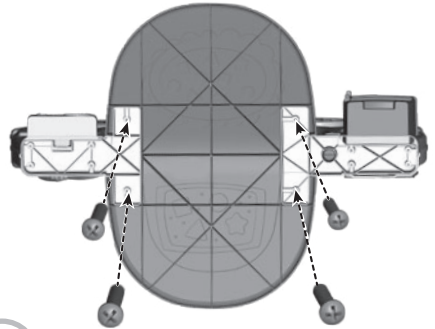

9

BOTTOM VIEW

- Carefully turn the assembly on its side again.
- Insert four screws into the bases and tighten.

## Assembly

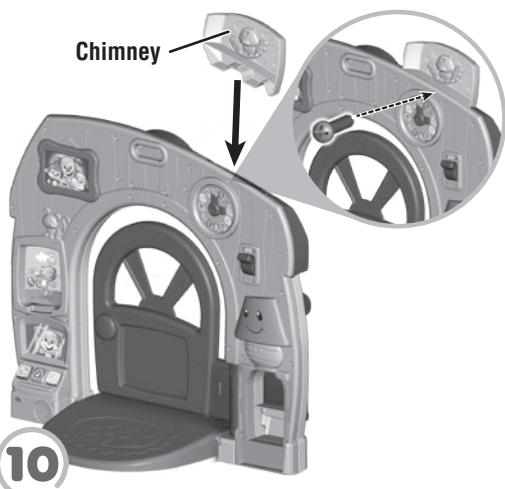

10

- Turn the assembly upright.
- Fit the chimney to the top of the assembly.
- Insert a screw into the wall assembly. Tighten the screw to secure the chimney.

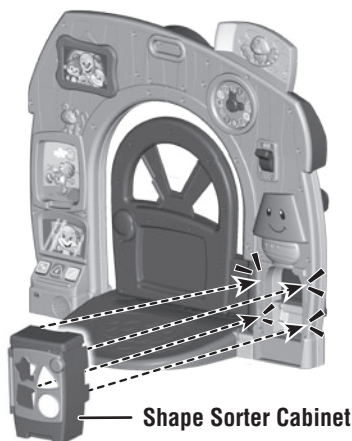

11

- “**Snap**” the shape sorter cabinet to the wall assembly.

## Battery Installation

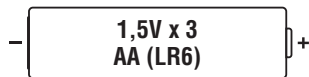

For longer life, use **alkaline** batteries.

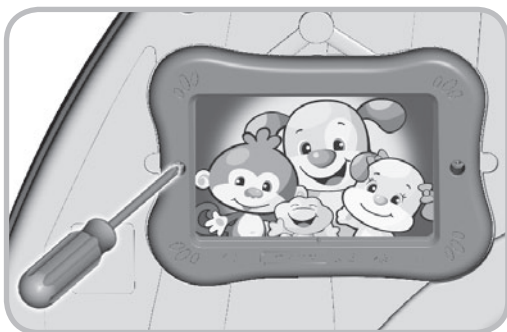

- Loosen the screws in the battery compartment door and remove the door.
- Insert three, new AA (LR6) **alkaline** batteries.
- Replace the battery compartment door and tighten the screws.
- If this toy begins to operate erratically you may need to reset the electronics. Remove the batteries and reinstall.
- When sound or lights from this toy become faint or stop, it's time for an adult to change the batteries.

**Hint:** After re-installing or changing batteries, you may need to re-input your child's age to use the automatic learning content feature. See next page to “Enter Baby's Age”.



## Battery Safety Information

**In exceptional circumstances, batteries may leak fluids that can cause a chemical burn injury or ruin your product. To avoid battery leakage:**

- Do not mix old and new batteries or batteries of different types: alkaline, standard (carbon-zinc) or rechargeable (nickel-cadmium).
- Insert batteries as indicated inside the battery compartment.
- Remove batteries during long periods of non-use. Always remove exhausted batteries from the product. Dispose of batteries safely. Do not dispose of this product in a fire. The batteries inside may explode or leak.
- Never short-circuit the battery terminals.
- Use only batteries of the same or equivalent type, as recommended.
- Do not charge non-rechargeable batteries.
- Remove rechargeable batteries from the product before charging.
- If removable, rechargeable batteries are used, they are only to be charged under adult supervision.

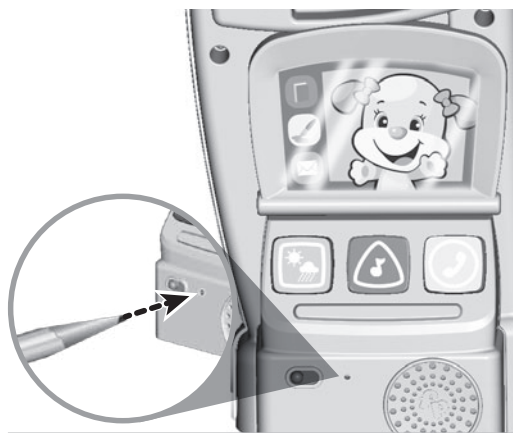
## Enter Baby's Age





- After installing batteries, turn power on. Listen to the voice prompt to set your child's current age. Press the shape buttons on the computer:
  -  Green button to increase months of age.
  -  Yellow button to decrease months of age.
  -  Red button to save your child's age.
- If you would like to reset the automatic age feature, simply insert a pointed object into the reset hole near the power/volume switch.

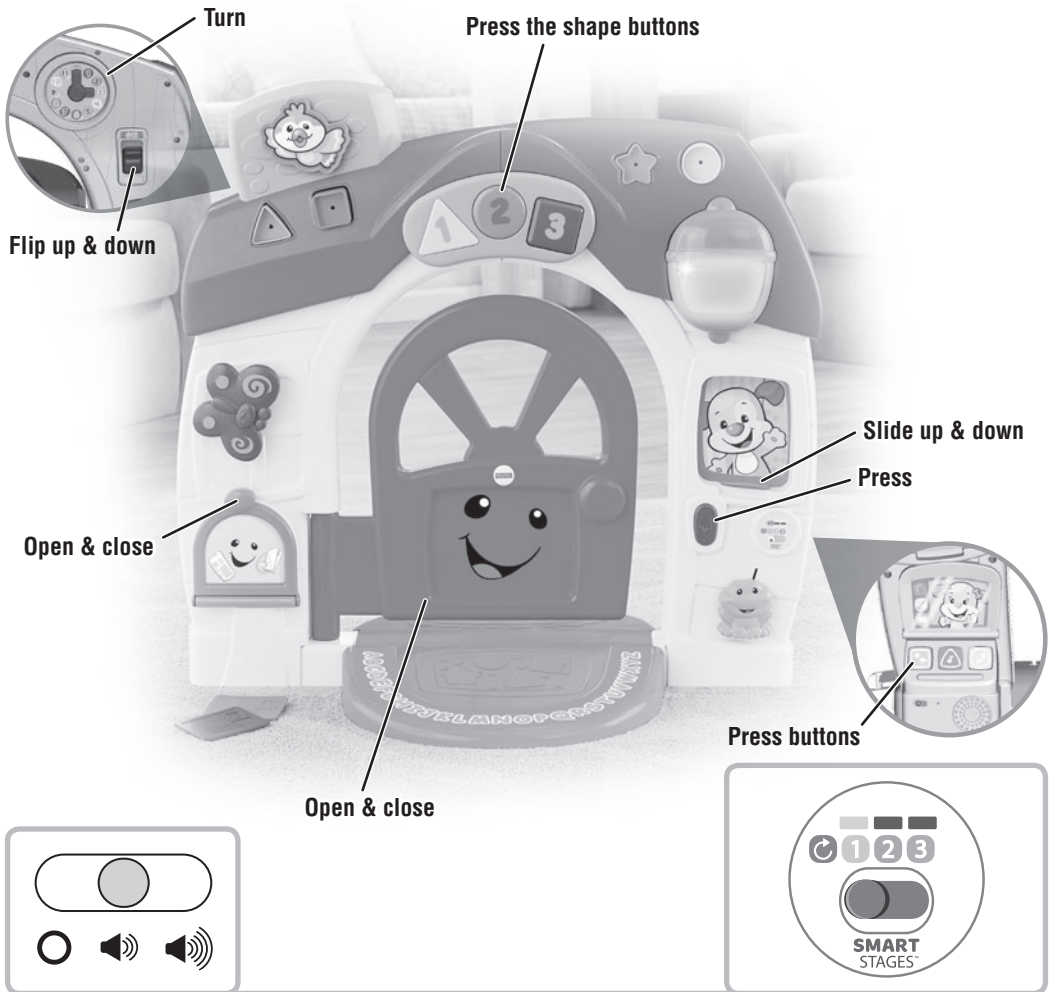

# Learning as baby grows!



- Slide the power/volume switch to ON with low volume , ON with high volume  or OFF .

- Slide the Smart Stages™ mode switch to:
  -  Learning content automatically changes as baby grows!
  - 1 Explore - 6M+**  
First words and sounds spark baby's curiosity.
  - 2 Encourage - 12M+**  
Prompt baby through questions and simple directions.
  - 3 Pretend - 18M+**  
Imaginative fun and early role play.