

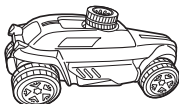

## EXTREME SHOXX™ TRIPLE AIR CHALLENGE™

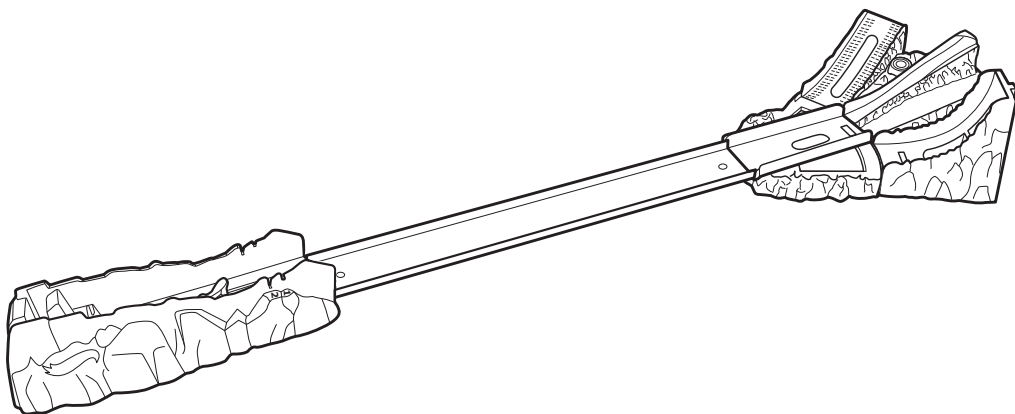

4+

[service.mattel.com](http://service.mattel.com)

**HOTWHEELS.COM**



BGL48-0920G1

PLEASE KEEP THESE INSTRUCTIONS FOR FUTURE REFERENCE AS THEY CONTAIN IMPORTANT INFORMATION.

# CONTENTS

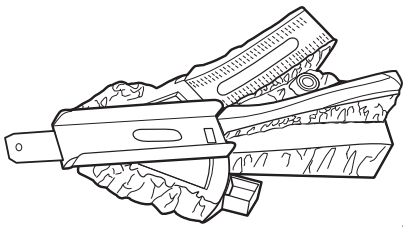

LABEL SHEET

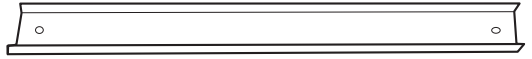
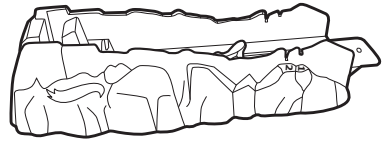

## APPLY LABELS

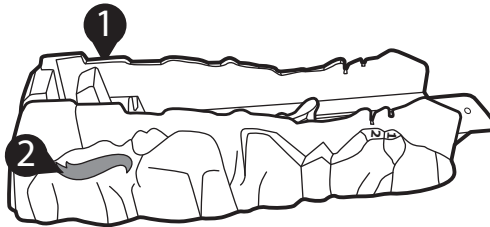

## ASSEMBLY

1.

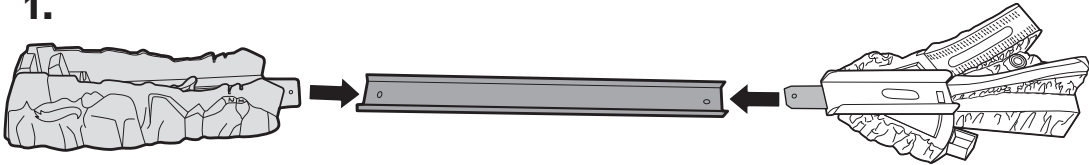

2.

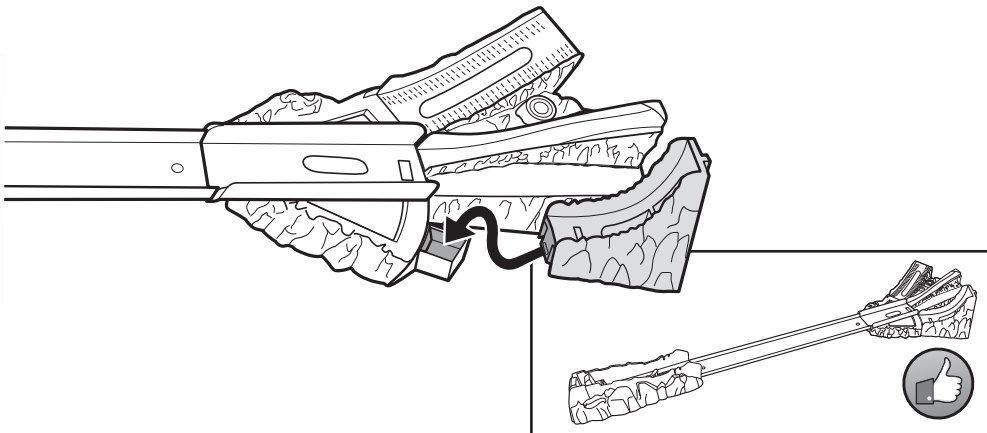

# TO PLAY

## 1. ADJUST YOUR VEHICLE'S SUSPENSION TO FIND THE BEST PERFORMANCE FOR THIS SET.

Rotate dial counter-clockwise for more suspension.

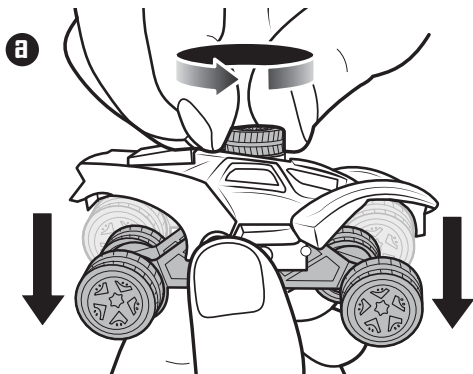

Rotate dial clockwise for less suspension.

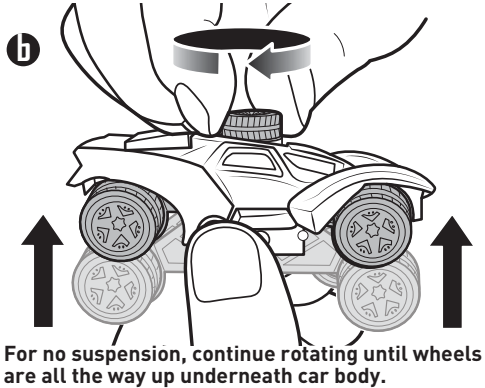

## 2. ATTACH VEHICLE TO LAUNCH LEVER, THEN PULL BACK TO LOCK INTO PLACE.

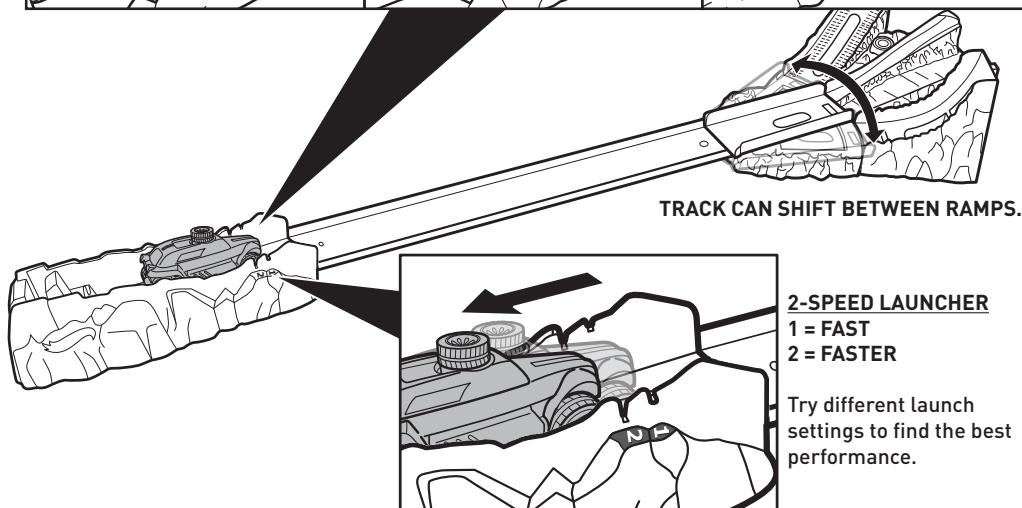
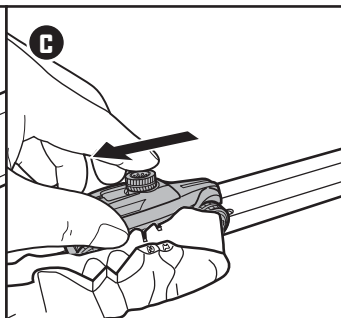
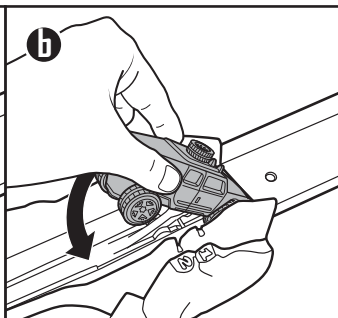
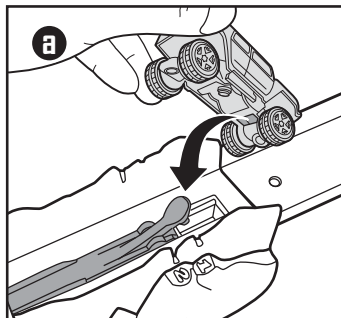

# TO PLAY (CONTD.)

## 3. DO A LONG JUMP FROM THE LEFT RAMP!

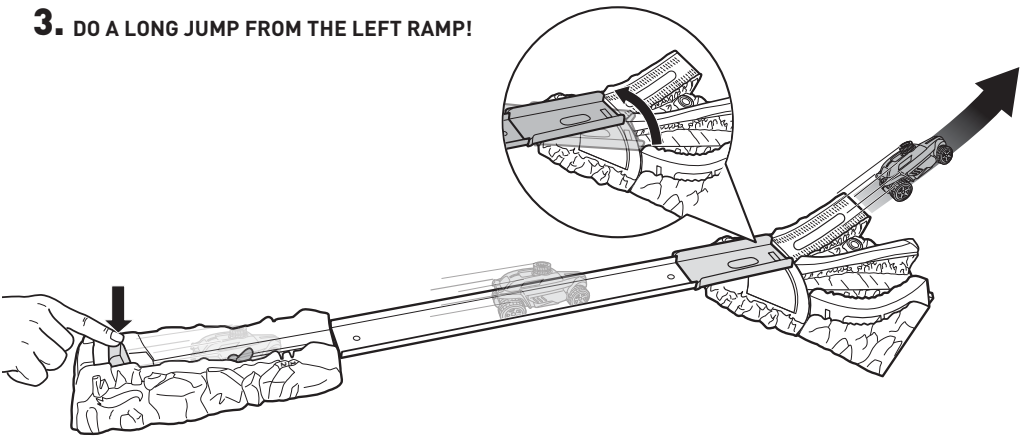

## 4. DO A MEGA FLIP FROM THE RIGHT RAMP!

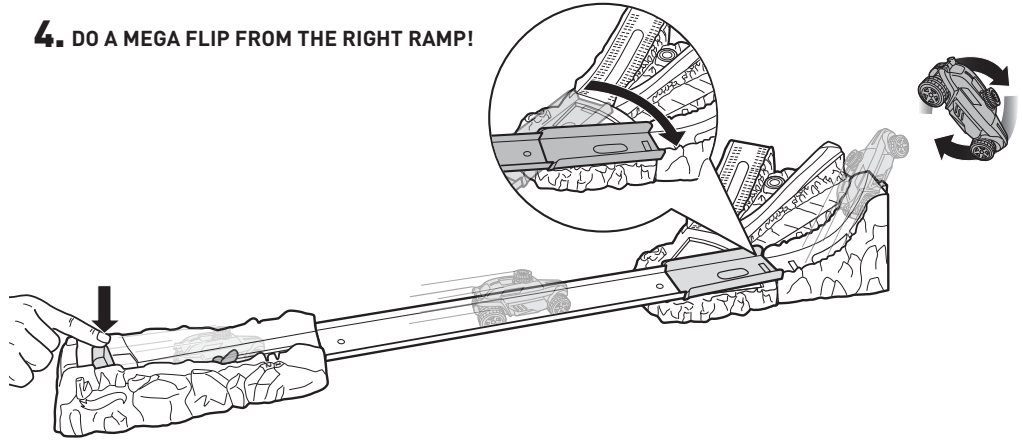

## 5. TRY A CORKSCREW ON THE MIDDLE RAMP (TOUGHEST STUNT)!

