

Please keep these instructions for future reference as they contain important information.

1 CONTENTS / 4+

Pieces combine and recombine!
Create 30 different space vehicles!

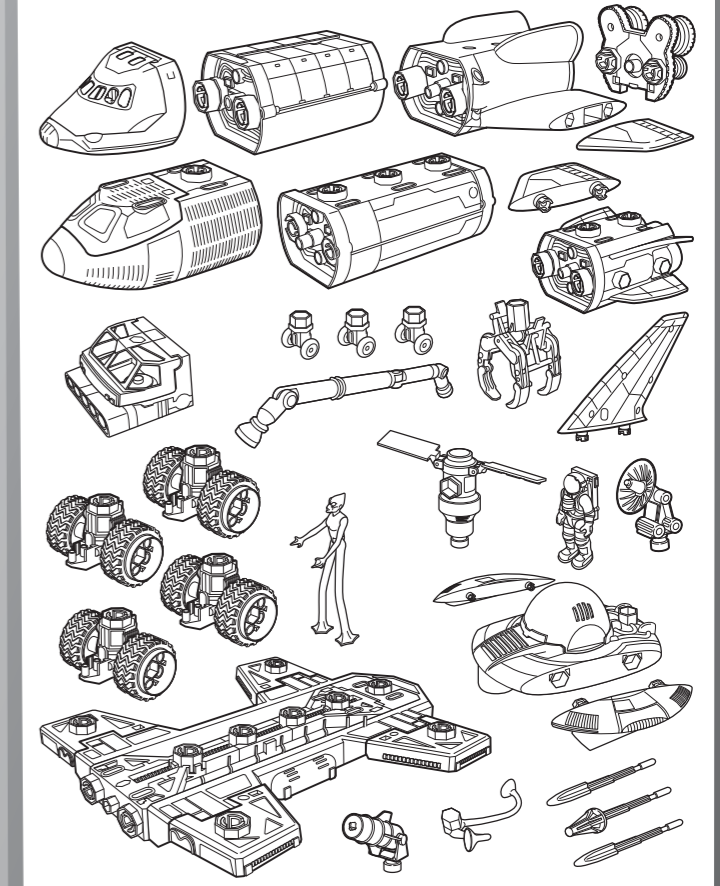

WARNING:
CHOKING HAZARD - Small parts.
Not for children under 3 years.

BJF04-0920



Dispose of batteries safely. Requires 3 - AG13 (LR44) button cell batteries or equivalent batteries. (Included batteries for demonstration only.)

©2013 Mattel. All Rights Reserved. Mattel, Inc., 636 Girard Avenue, East Aurora, NY 14052, U.S.A. Consumer Relations 1-800-524-8697. Mattel U.K. Ltd., Vanwall Business Park, Maidenhead SL6 4UB. Helpline 01628 500303. Mattel Australia Pty., Ltd., Richmond, Victoria. 3121. Consumer Advisory Service - 1300 135 312. Mattel East Asia Ltd., Room 503-09, North Tower, World Finance Centre, Harbour City, Tsimshatsui, HK, China. Diimport & Diedarkan Oleh: Mattel SEA Ptd Ltd.(993532-P) Lot 13.5, 13th Floor, Menara Lien Hoe, Persiaran Tropicana Golf Country Resort, 47410 PJ, Malaysia. Tel:03-78803817, Fax:03-78803867. SERVICE.MATTEL.COM

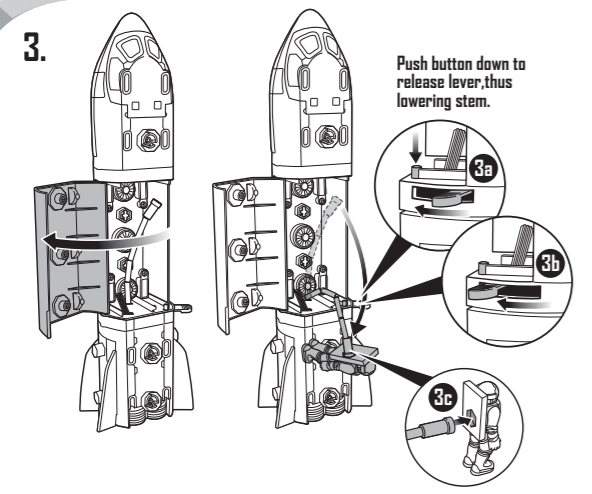

Push button down to release lever, thus lowering stem.

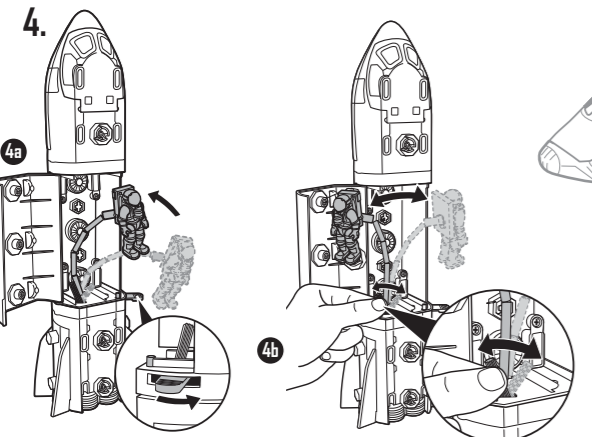

Push lever all the way backward to raise up and lock astronaut in place.

Move lever to move the astronaut from side to side.

8 TRANSPORT EQUIPMENT WITH THE ASTRO GRABBER.

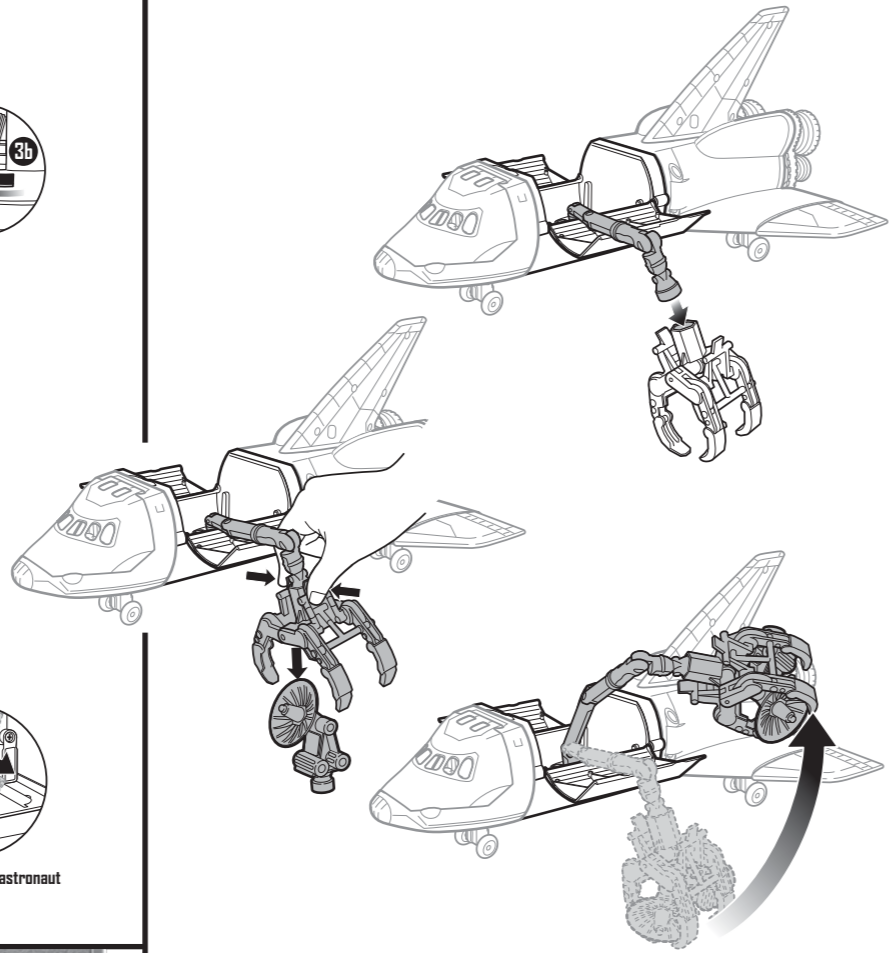

7 USE THE SPACE TETHER AND SATELLITE

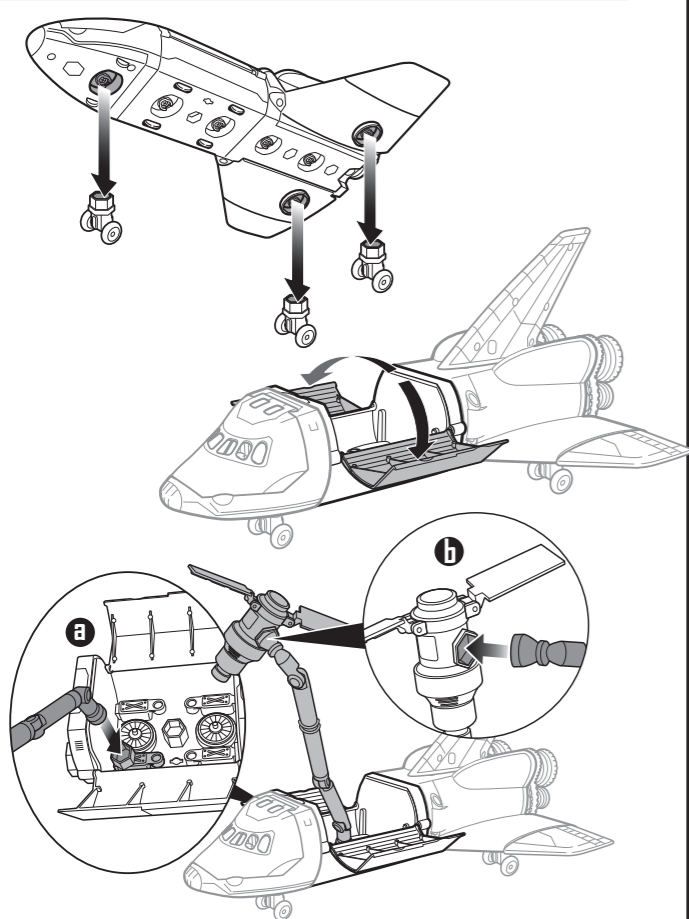

You can combine the wheels (chassis) in many ways...

Connect to first post as shown.

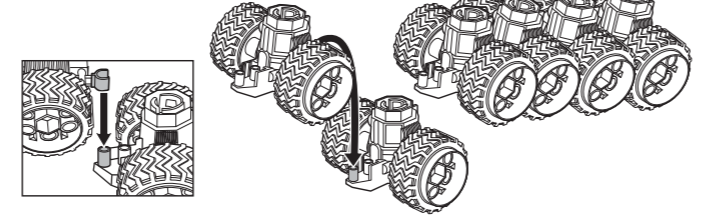

Connect to second post as shown.

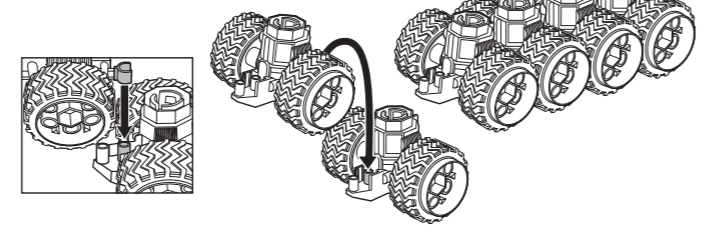

Connect side-by-side as shown.

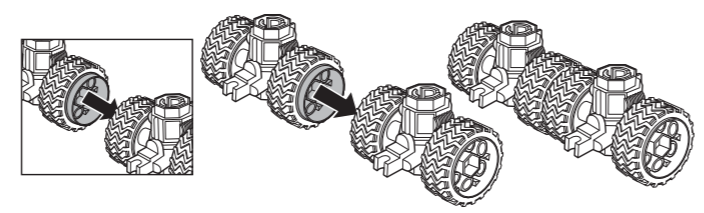

9 CAN YOU BUILD THESE?

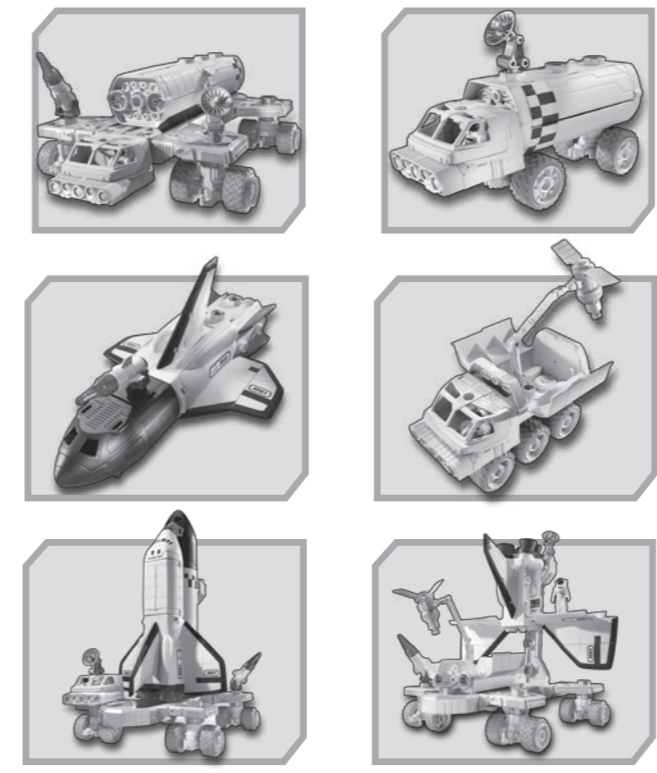

10 COMBINES WITH ANY MEGA RIG® SET!

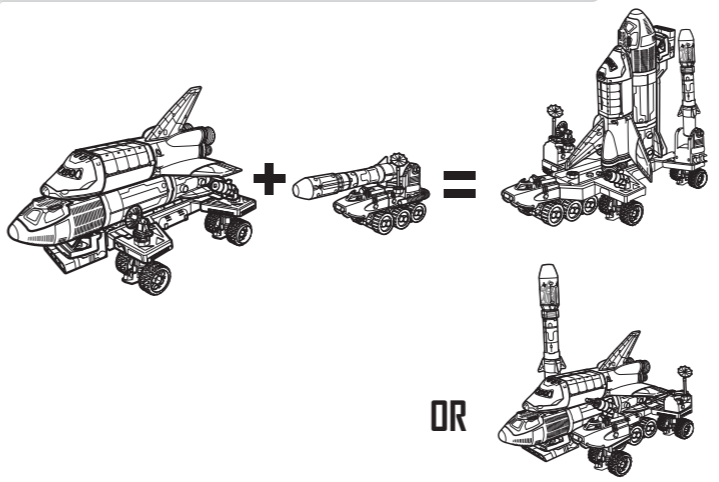

This device complies with Part 15 of the FCC Rules. Operation is subject to the following two conditions:
(1) This device may not cause harmful interference, and (2) this device must accept any interference received, including interference that may cause undesired operation.

- This equipment has been tested and found to comply with the limits for a Class B digital device, pursuant to part 15 of the FCC rules. These limits are designed to provide reasonable protection against harmful interference in a residential installation. This equipment generates, uses and can radiate radio frequency energy and, if not installed and used in accordance with the instructions, may cause harmful interference to radio communications. However, there is no guarantee that interference will not occur in a particular installation. If this equipment does cause harmful interference to radio or television reception, which can be determined by turning the equipment off and on, the user is encouraged to try to correct the interference by one or more of the following measures:
- Reorient or relocate the receiving antenna.
- Increase the separation between the equipment and receiver.
- Connect the equipment into an outlet on a circuit different from that to which the receiver is connected.
- Consult the dealer or an experienced radio/TV technician for help.

NOTE: Changes or modifications not expressly approved by the manufacturer responsible for compliance could void the user's authority to operate the equipment.

2 BATTERY REPLACEMENT

- Unscrew the battery cover with a Phillips head screwdriver (not included).
- Remove batteries included for demonstration purposes and dispose of them safely. Install 3 new button cell (AG13, LR44) batteries in the orientation (+/-) shown.
- Replace battery cover and tighten screw.
- Replace the batteries if the lights dim or the sounds are garbled.

UFO BOTTOM VIEW

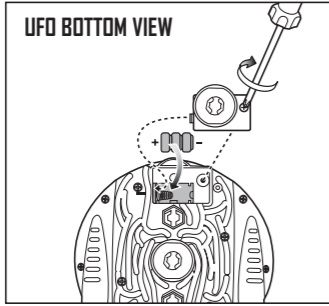

RECYCLE INFORMATION (USA ONLY)

Please recycle button cell battery(ies) contained in this product by:

- Visiting your nearest recycling center. For location of the nearest recycling center, visit us online at www.service.mattel.com.
- If a recycling center is not available in your area, contact us for a pre-paid mailing label. Visit us online at www.service.mattel.com or call toll-free at 1-800-524-8697. • Valid in the US only.

BATTERY SAFETY INFORMATION

In exceptional circumstances batteries may leak fluids that can cause a chemical burn injury or ruin your product. To avoid battery leakage:

- Non-rechargeable batteries are not to be recharged.
- Rechargeable batteries are to be removed from the product before being charged.
- Rechargeable batteries are only to be charged under adult supervision.
- Do not mix alkaline, standard (carbon-zinc), or rechargeable (nickel-cadmium) batteries.

- Do not mix old and new batteries.
- Only batteries of the same or equivalent type as recommended are to be used.
- Batteries are to be inserted with the correct polarity.
- Exhausted batteries are to be removed from the product.
- The supply terminals are not to be short-circuited.
- Dispose of battery(ies) safely.
- Do not dispose of this product in a fire. The batteries inside may explode or leak.



Protect the environment by not disposing of this product with household waste (2002/96/EC). Check your local authority for recycling advice and facilities.

3 ASSEMBLY

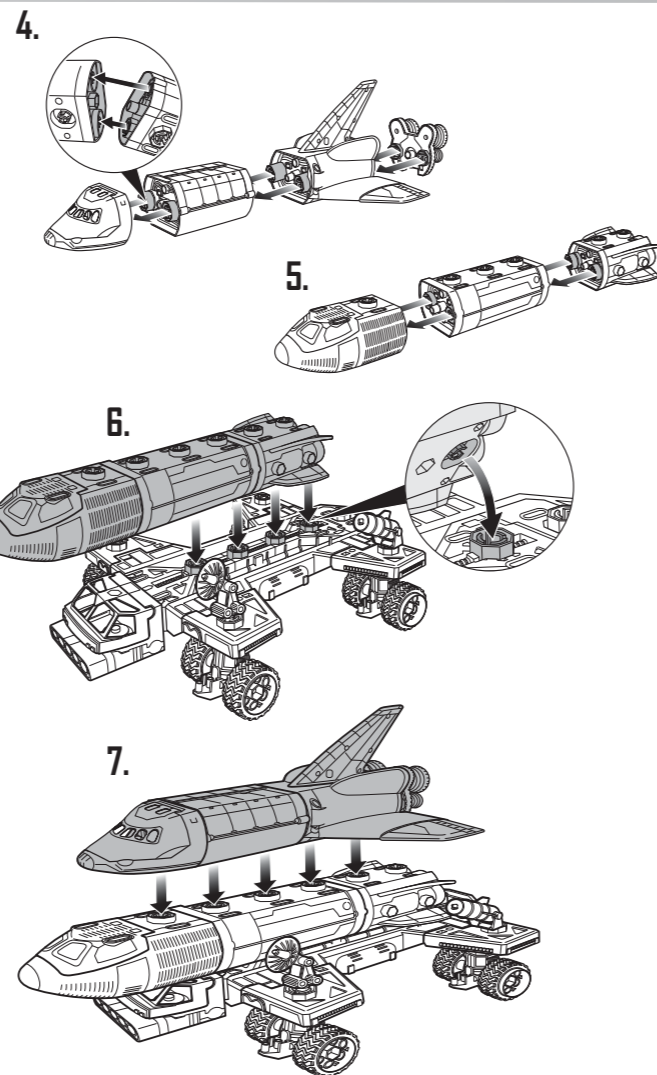
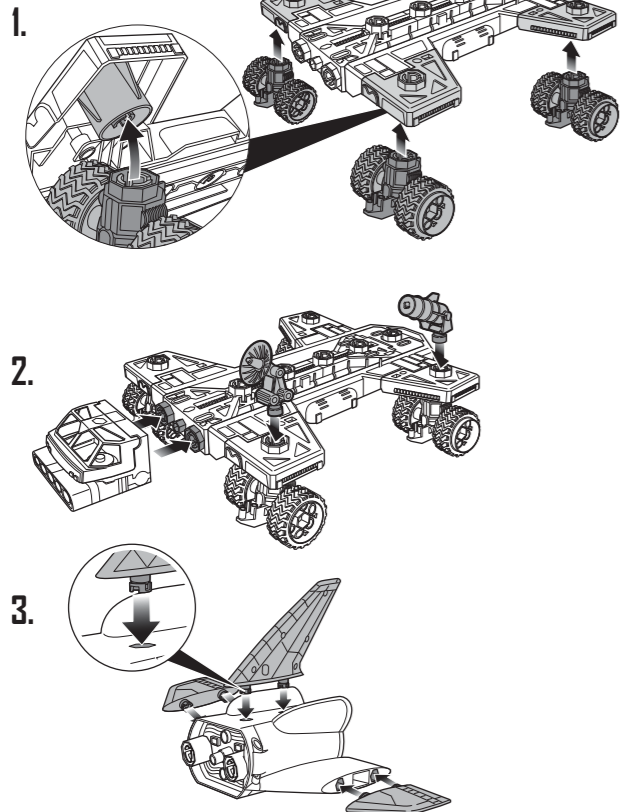

COMPLETED ASSEMBLY

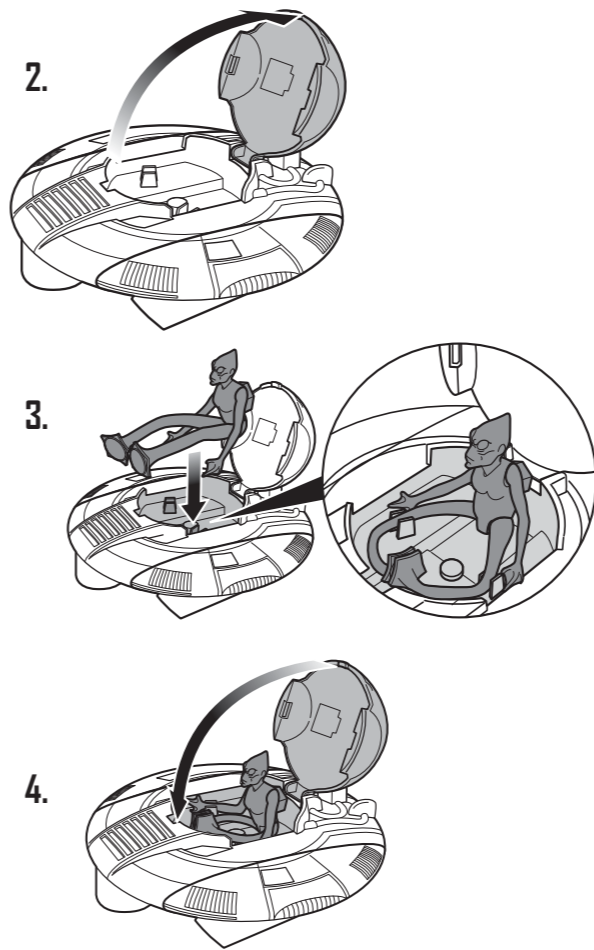
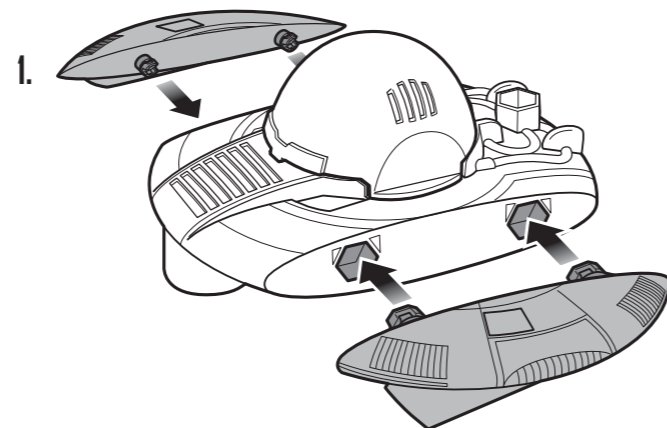

4 TORPEDO LAUNCHER

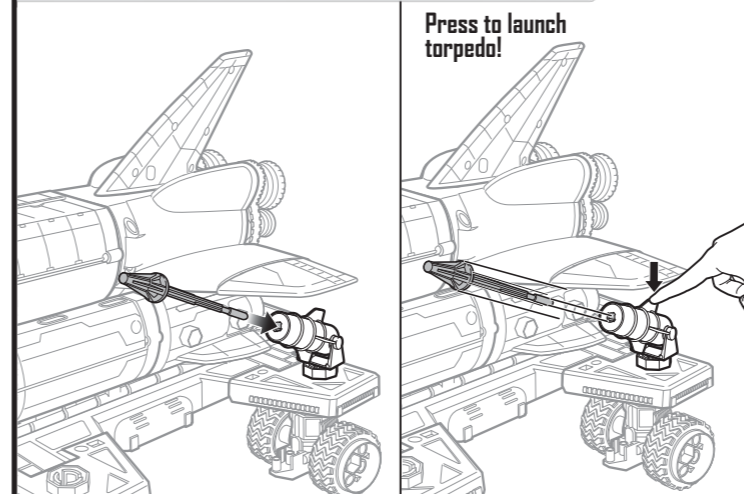

5 UFO MISSILES

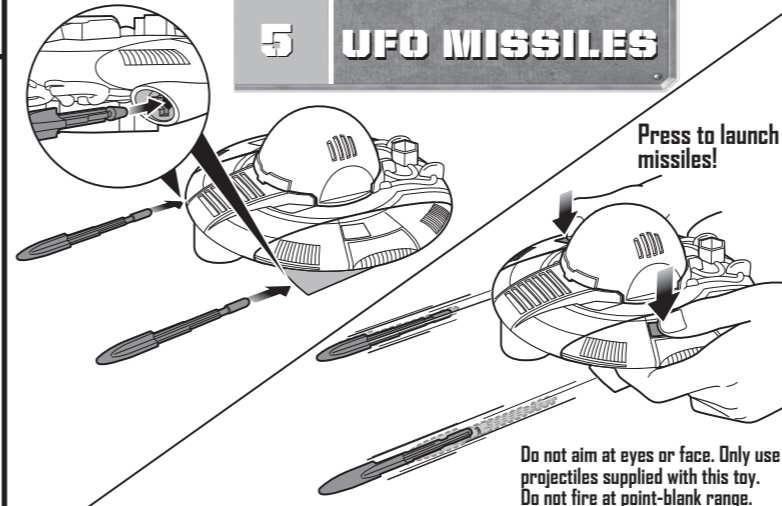

6 TO PLAY

The alien has captured the astronaut!

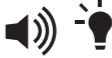
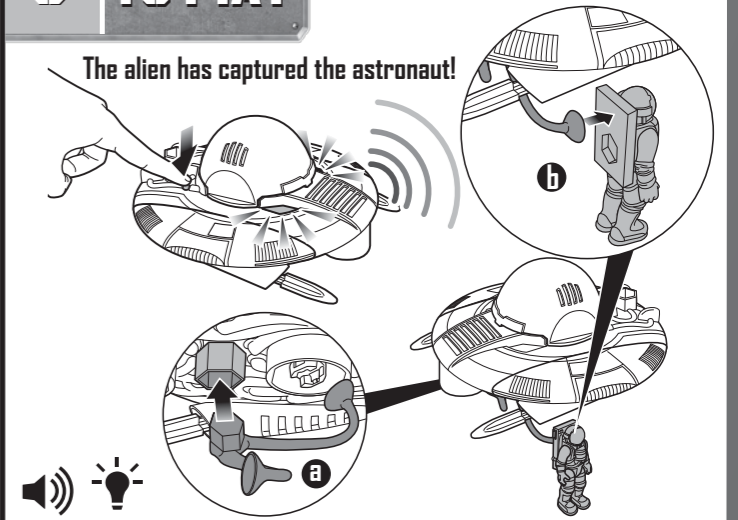

Your Matchbox® astronaut and alien fit inside many places.

