

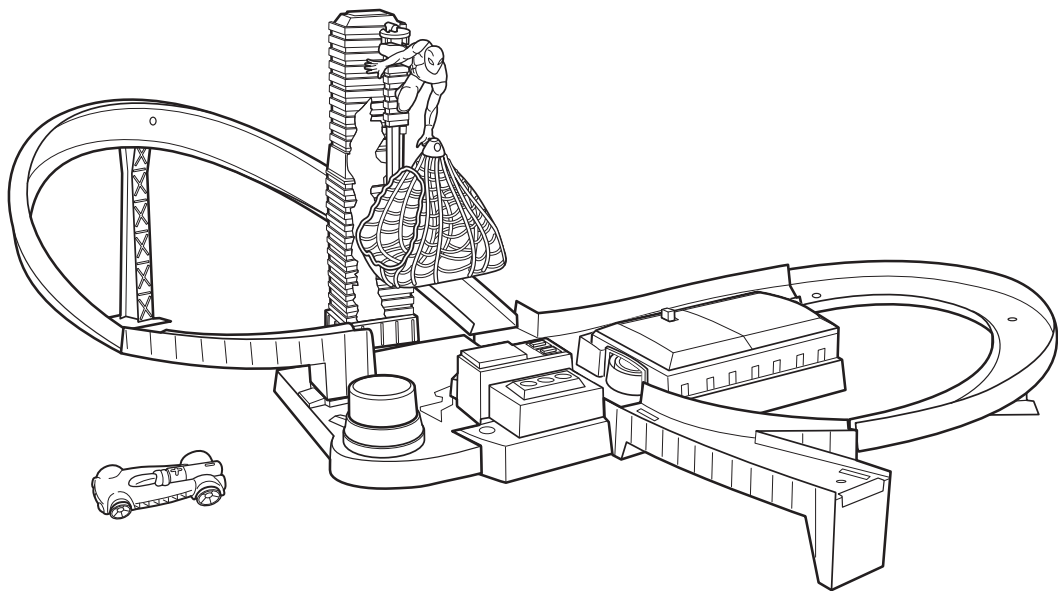

## THE AMAZING SPIDER-MAN 2™

### SPEED CIRCUIT SHOWDOWN™ SPIDER-MAN VS. ELECTRO



Requires 2 "D" (LR20) Alkaline batteries (not included). Dispose of batteries safely.

**4+**

service.mattel.com

**HOTWHEELS.COM**



BLV61-0920

PLEASE KEEP THESE INSTRUCTIONS FOR FUTURE  
REFERENCE AS THEY CONTAIN IMPORTANT INFORMATION.

# CONTENTS

## LABEL SHEET

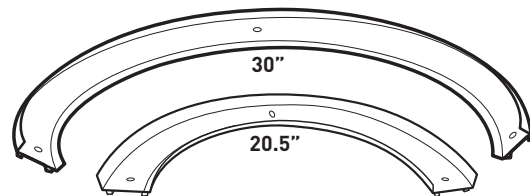
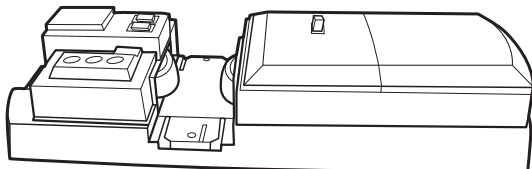
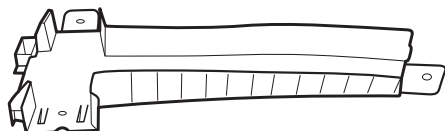
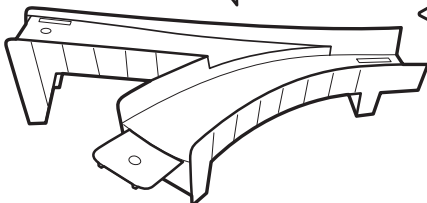
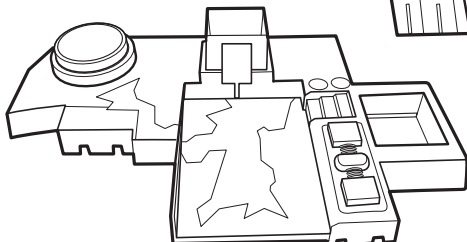
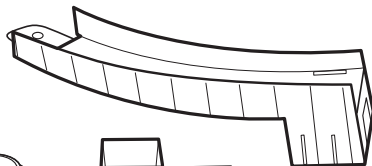
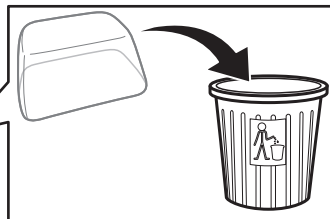
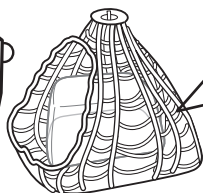
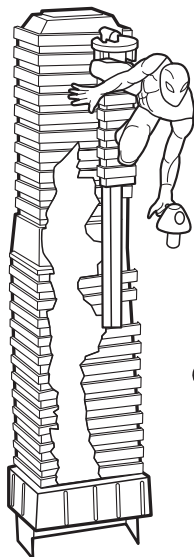
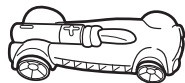
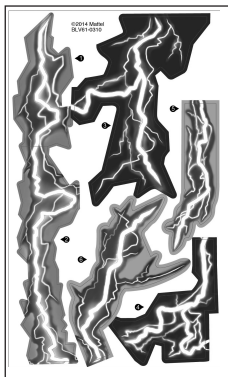

## APPLY LABELS

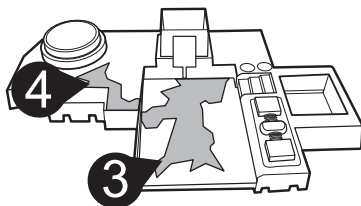
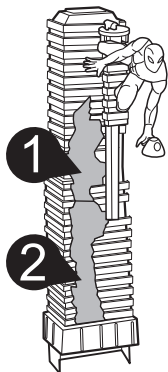

6

# BATTERY INSTALLATION

- Unscrew the battery cover with a Phillips head screwdriver (not included).
- Install 2 new "D" size (LR20) alkaline batteries in the orientation (+/-) shown.
- Replace battery cover and tighten screw.
- Replace batteries when booster can no longer propel car through the track set.
- For best performance, use only alkaline batteries.

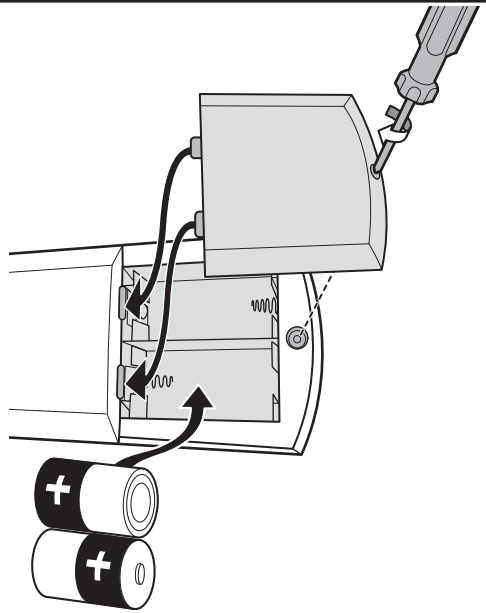

## BATTERY SAFETY INFORMATION

In exceptional circumstances batteries may leak fluids that can cause a chemical burn injury or ruin your product.

To avoid battery leakage:

- Non-rechargeable batteries are not to be recharged.
- Rechargeable batteries are to be removed from the product before being charged.
- Rechargeable batteries are only to be charged under adult supervision.
- Do not mix alkaline, standard (carbon-zinc), or rechargeable (nickel-cadmium) batteries.
- Do not mix old and new batteries.
- Only batteries of the same or equivalent type as recommended are to be used.
- Batteries are to be inserted with the correct polarity.
- Exhausted batteries are to be removed from the product.
- The supply terminals are not to be short-circuited.
- Dispose of battery(ies) safely.
- Do not dispose of this product in a fire. The batteries inside may explode or leak.



Protect the environment by not disposing of this product with household waste [2002/96/EC].  
Check your local authority for recycling advice and facilities.

## OPERATING TIPS

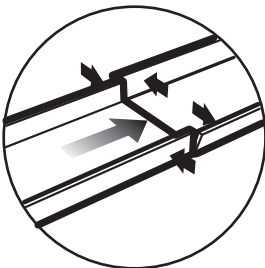

Adjust track side walls at each connection point as shown.

# ASSEMBLY

1.

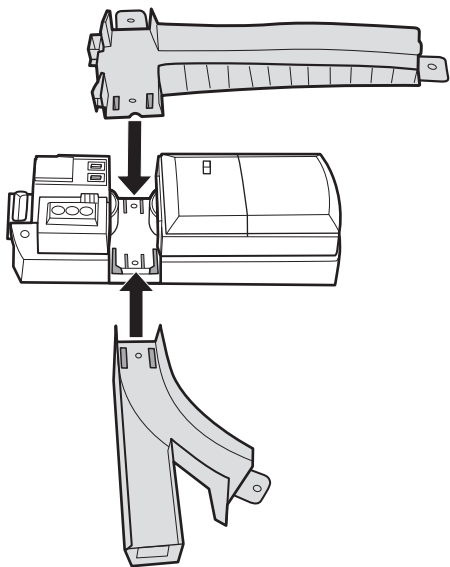

2.

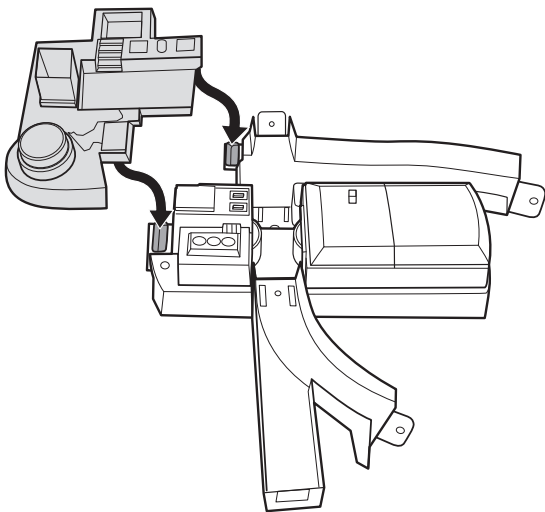

3.

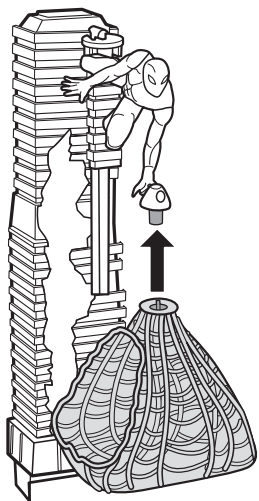

ONE-TIME SNAP.

4.

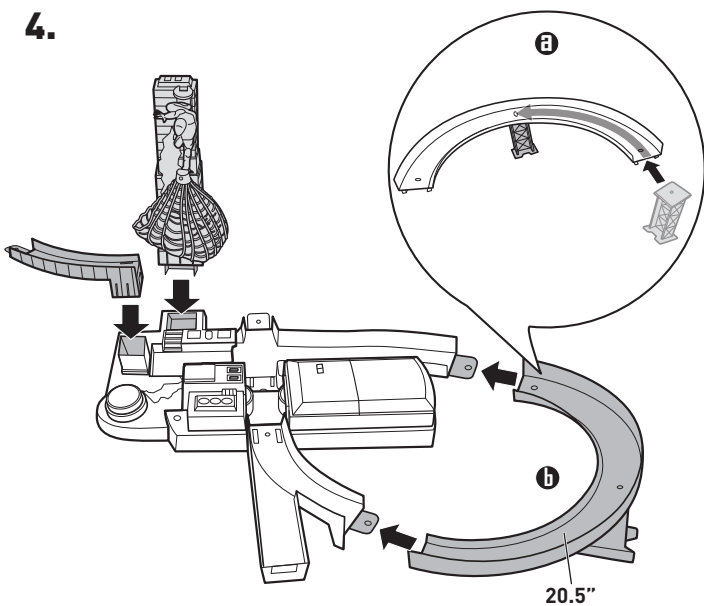

# ASSEMBLY (CONTD.)

5.

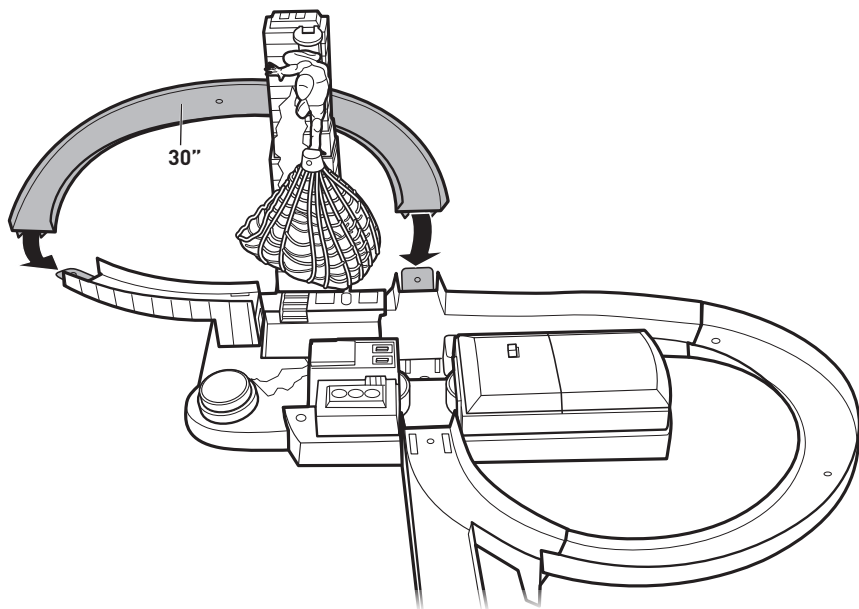

6.

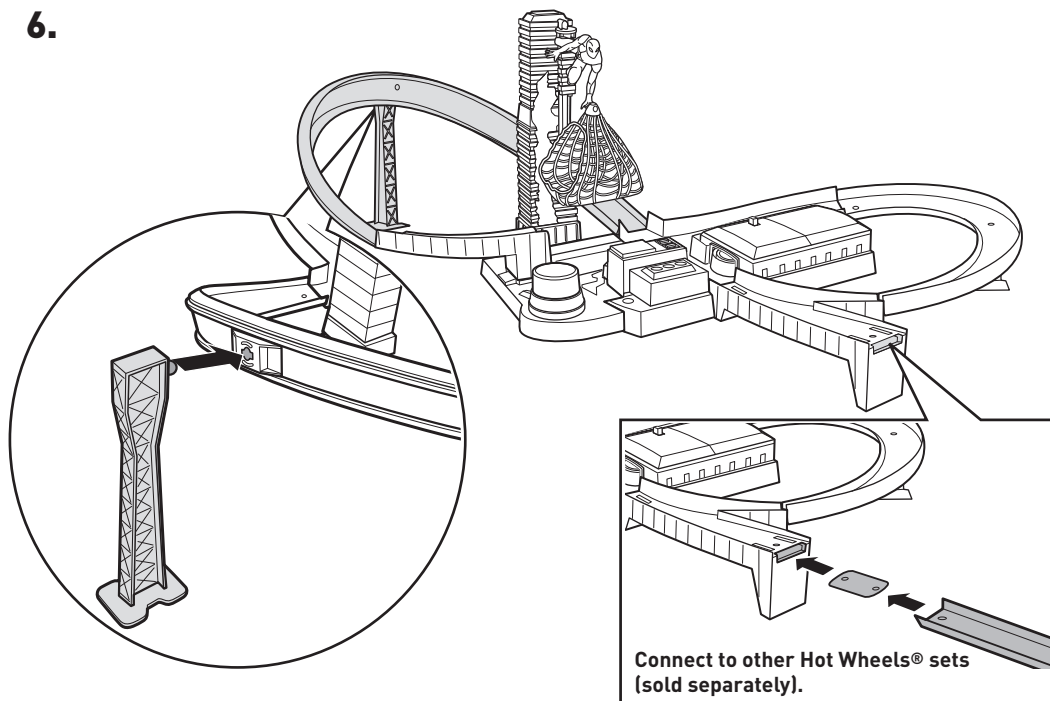

# TO PLAY

- 1. Power ON (I) and push Spider-Man's web down to set up the trap.**

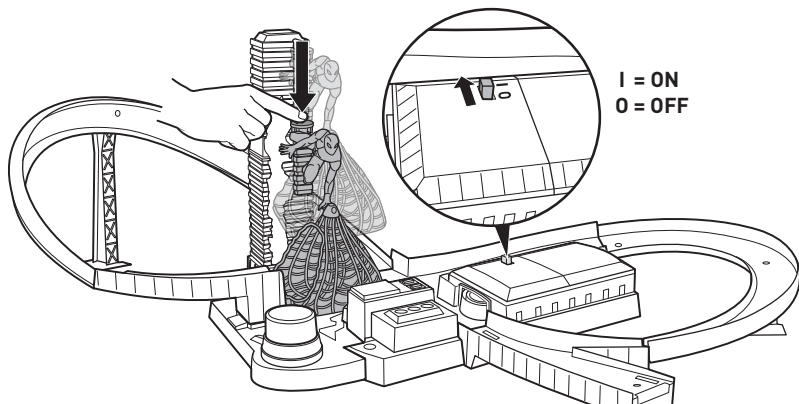

- 2. Push Electro car through motorized booster and watch it speed around the track.**

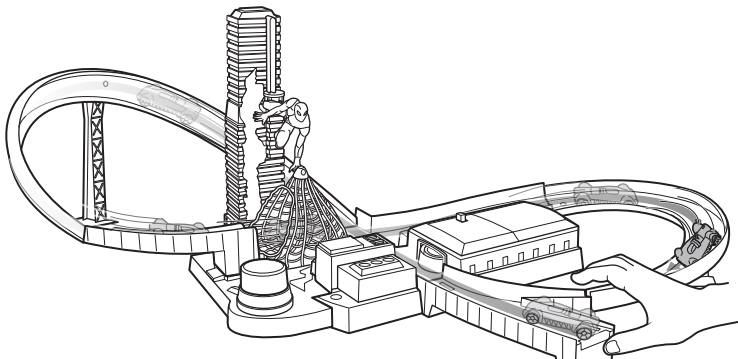

- 3. Pound button at the right time to catch Electro in the web.**

