

Model  
C6998



**imaginext**™ SYSTEM

Fisher-Price®

[www.fisher-price.com](http://www.fisher-price.com)

# Welcome to the Imaginext™ System

## **Younger children & those new to the Imaginext™ System**

*Use our step-by-step instructions to build the structure shown on the cover of this booklet. Encourage your child to assist you with some of the simple steps. This assembly is ideal for active play and it can be used as a playset rather than a building toy.*



## **Older children and experienced Imaginext™ System users**

*The more your child plays with this toy, and development and skill increases, the less assistance your child needs! Experienced Imaginext™ users will enjoy using all parts of this toy to build their own structures or try building an alternate assembly shown below.*



Product features and decorations may vary from the photos and illustrations in these instructions.

# Let's Build It!

1.

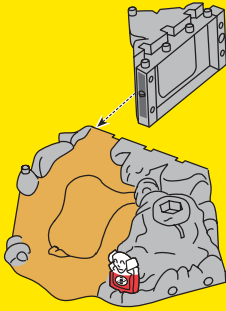

2.

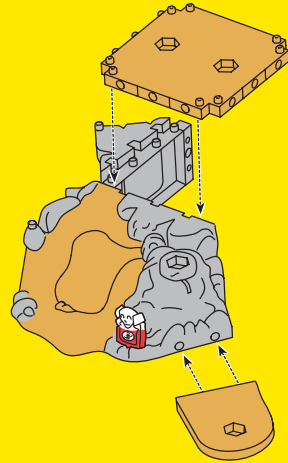

3.

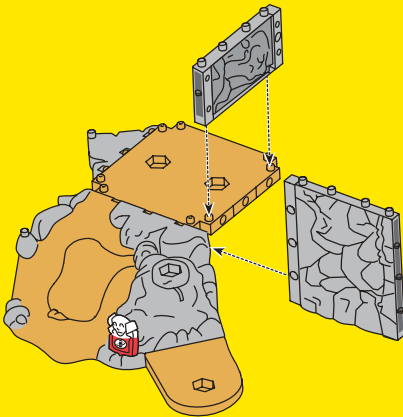

4.

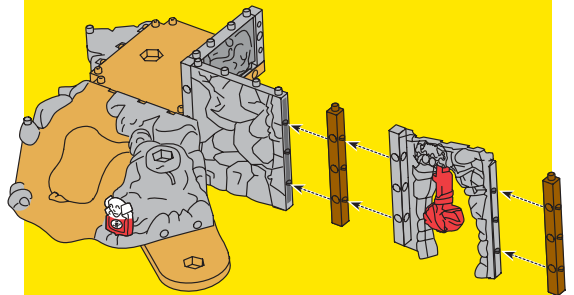

# Let's Build It!

5.

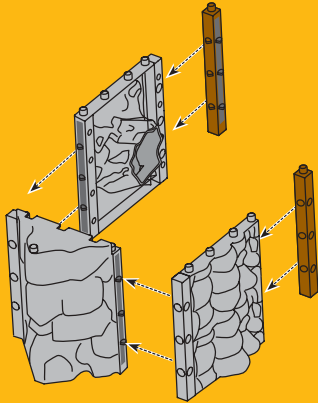

6.

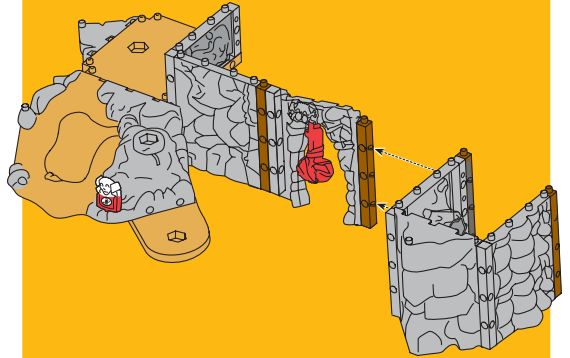

7.

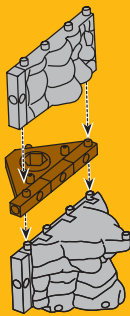

8.

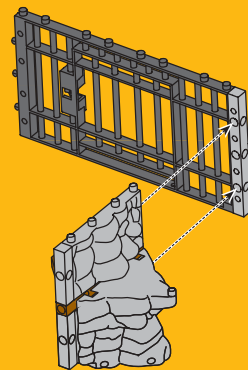

# Let's Build It!

9.

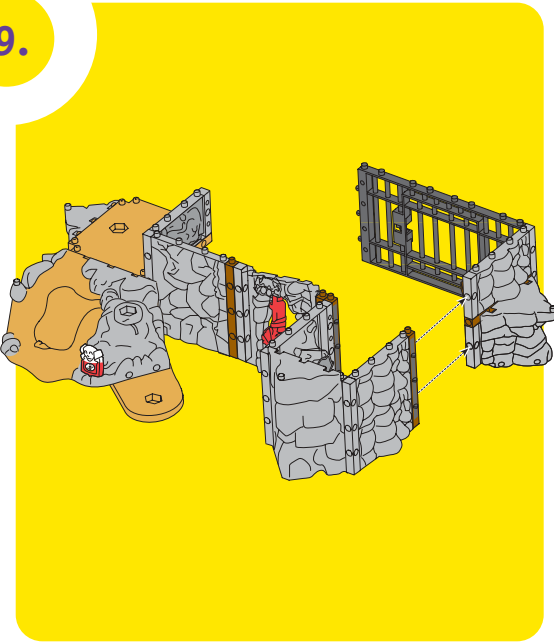

10.

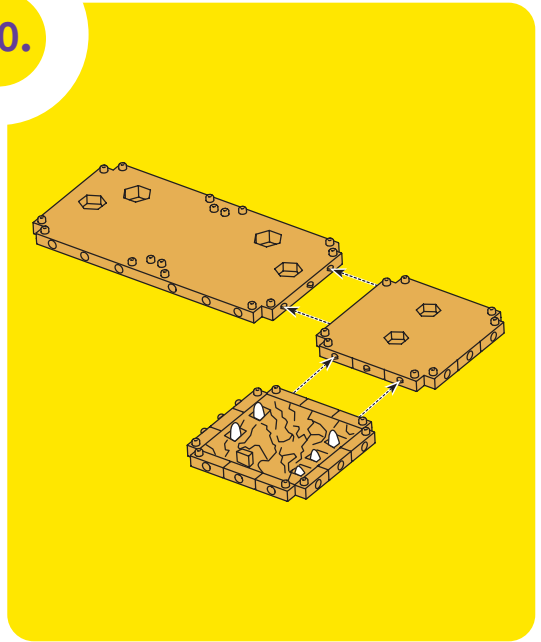

11.

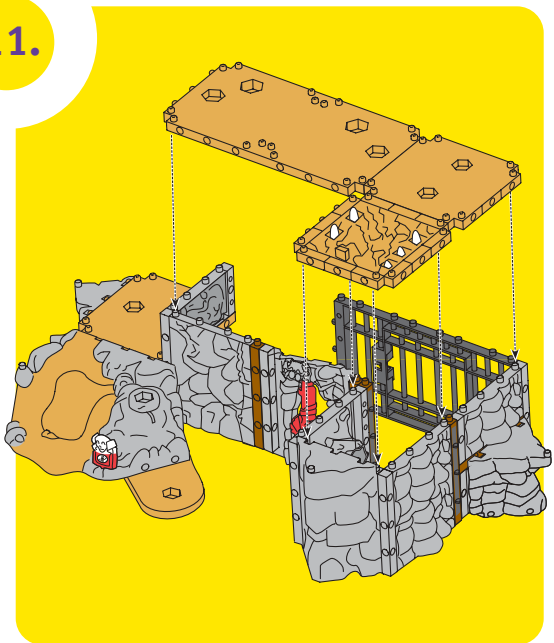

12.

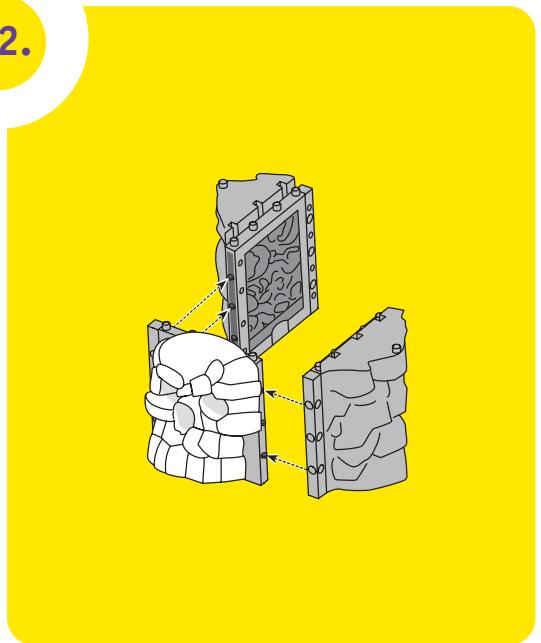





# Come to the Secret Island Hideout!



Press down on the center of the volcano and load the "lava" chips. Press the secret idol to see the volcano "erupt"!



Press the button on the platform and the skeleton cage springs up to trap prisoners!



Press the target and the spiked pendulum swings down!



Press the target and the skeleton hand falls to capture intruders.

## WARNING

Warning – Choking Hazard  
Not recommended for children under 3 years because it contains small parts that can be swallowed.

### IMPORTANT!

The glow-in-the-dark feature will last longer if you do not expose this toy to intense heat or direct sunlight for prolonged periods of time. Place the glow-in-the-dark items approximately five feet (1.52 m) away from a light source for 30 seconds. Placing the items closer will not intensify the glow-in-the-dark feature.



### Care

Wipe the toy with a clean cloth dampened with a mild soap and water solution.  
Do not immerse the toy.

**Please keep this instruction sheet for future reference, as it contains important information.  
For children 4-10 years.**

### Questions? We'd like to hear from you!

Call Fisher-Price® Consumer Relations, toll-free at **1-800-432-5437**, 8 AM - 6 PM EST  
Monday through Friday. Hearing-impaired consumers using TTY/TDD equipment,  
please call 1-800-382-7470. Or, write to:  
Fisher-Price® Consumer Relations, 636 Girard Avenue, East Aurora, New York 14052, U.S.A.

#### For countries outside the United States:

**CANADA** Questions? 1-800-567-7724 (KIDS). Mattel Canada Inc., 6155 Freemont Blvd., Mississauga, Ontario L5R 3W2

**GREAT BRITAIN** Mattel UK Ltd, Vanwall Business Park, Maidenhead SL6 4UB. Helpline: 01628 500302.

**AUSTRALIA** Mattel Australia Pty. Ltd., 658 Church Street, Locked Bag #870, Richmond, Victoria 3121 Australia.  
Consumer Advisory Service 1300 135 312.

**NEW ZEALAND** 16-18 William Pickering Drive, Albany 1331, Auckland.

**ASIA** Mattel East Asia Ltd, Room 1106, South Tower, World Finance Centre, Harbour City, Tsimshatsui, HK, China.