

### 3 STORAGE

DETACH COLLAR AND CHAIN. THEN STORE THEM IN THE TRAILER AFTER PLAY.

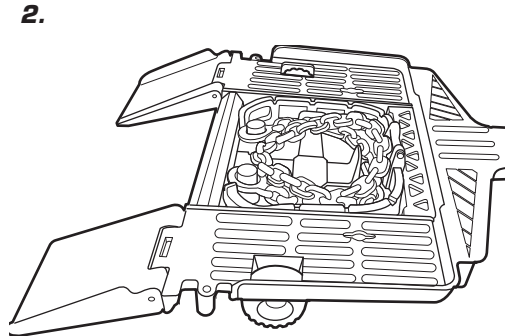
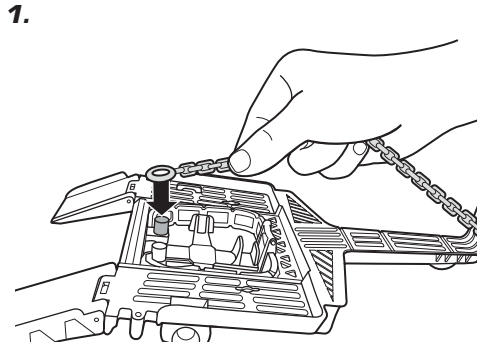

#### This device complies with Part 15 of the FCC Rules.

Operation is subject to the following two conditions: (1) This device may not cause harmful interference, and (2) this device must accept any interference received, including interference that may cause undesired operation.

- This equipment has been tested and found to comply with the limits for a Class B digital device, pursuant to part 15 of the FCC rules. These limits are designed to provide reasonable protection against harmful interference in a residential installation. This equipment generates, uses and can radiate radio frequency energy and, if not installed and used in accordance with the instructions, may cause harmful interference to radio communications. However, there is no guarantee that interference will not occur in a particular installation. If this equipment does cause harmful interference to radio or television reception, which can be determined by turning the equipment off and on, the user is encouraged to try to correct the interference by one or more of the following measures:
  - Reorient or relocate the receiving antenna.
  - Increase the separation between the equipment and receiver.
  - Connect the equipment into an outlet on a circuit different from that to which the receiver is connected.
  - Consult the dealer or an experienced radio/TV technician for help.

**NOTE:** Changes or modifications not expressly approved by the manufacturer responsible for compliance could void the user's authority to operate the equipment.

# MATCHBOX

ON A MISSION™



CDC71-0970G2  
1100424101\_DOM

## INSTRUCTIONS: MISSION™ DINO TRAPPER TRAILER™

Keep these instructions for future reference as they contain important information.

### CONTENTS

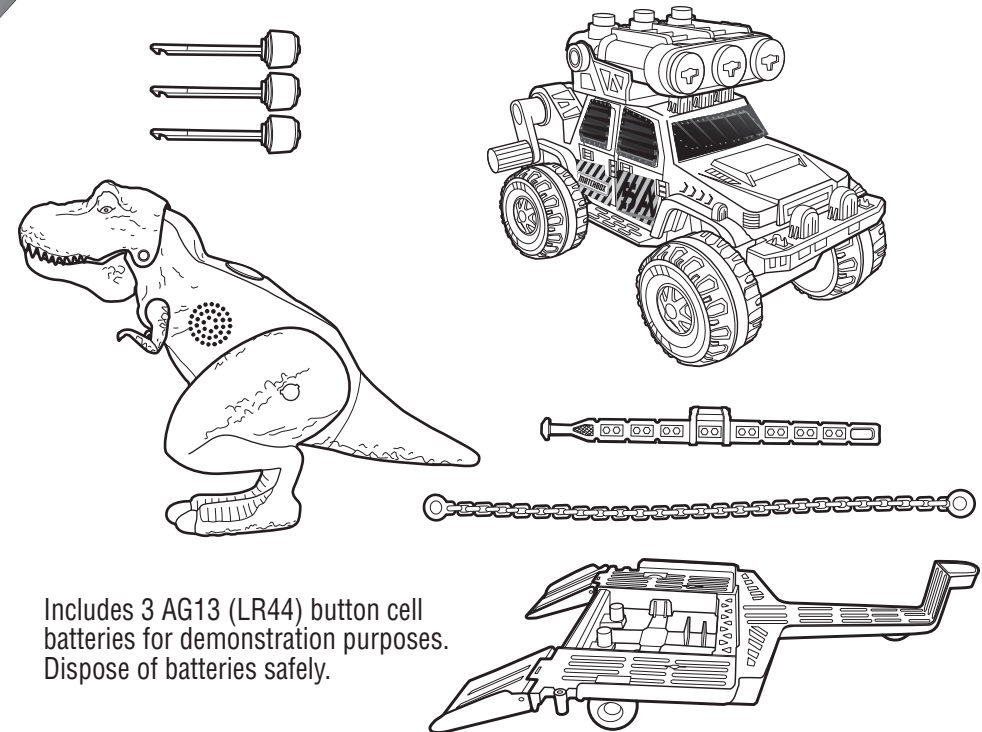

Includes 3 AG13 (LR44) button cell batteries for demonstration purposes. Dispose of batteries safely.

©2015 Mattel. All Rights Reserved. Mattel, Inc., 636 Girard Avenue, East Aurora, NY 14052, U.S.A. Consumer Services 1-800-524-8697. Mattel U.K. Ltd., Vanwall Business Park, Maidenhead SL6 4UB. Helpline 01628 500303. Mattel Australia Pty., Ltd., Richmond, Victoria. 3121. Consumer Advisory Service - 1300 135 312. Mattel East Asia Ltd., Room 503-09, North Tower, World Finance Centre, Harbour City, Tsimshatsui, HK, China. Tel.: (852) 3185-6500. Diimport & Diedarkan Oleh: Mattel Southeast Asia Pte. Ltd., No 19-1, Tower 3 Avenue 7, Bangsar South City, No 8, Jalan Kerinchi, 59200 Kuala Lumpur, Malaysia. Tel: 03-78803817, Fax: 03-78803867.

SERVICE.MATTEL.COM

# 1 BATTERY REPLACEMENT

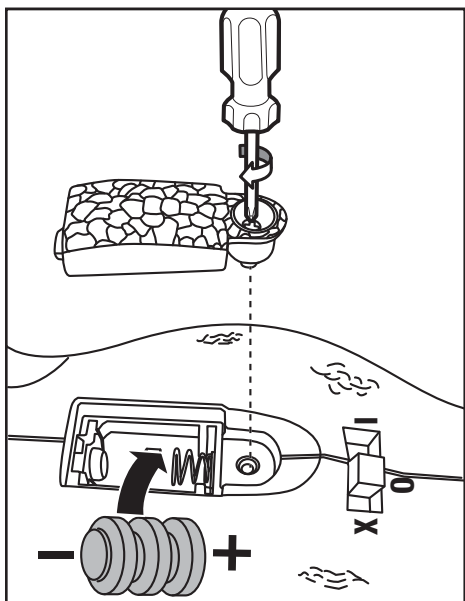

- Replace the batteries if sounds distort or lights dim.
- Unscrew the battery cover with a Phillips head screwdriver (not included).
- Remove batteries included for demonstration purposes and dispose of them safely.
- Install 3 new AG13 (LR44) button cell batteries in the orientation (+/-) shown.
- Replace battery cover and tighten screw.
- For longer life, use alkaline batteries.
- When exposed to an electrostatic source, the product may malfunction. To resume normal operation, remove and re-install the batteries.

# BATTERY SAFETY INFORMATION

In exceptional circumstances batteries may leak fluids that can cause a chemical burn injury or ruin your product. To avoid battery leakage:

- Non-rechargeable batteries are not to be recharged.
- Rechargeable batteries are to be removed from the product before being charged.
- Rechargeable batteries are only to be charged under adult supervision.
- Do not mix alkaline, standard (carbon-zinc), or rechargeable (nickel-cadmium) batteries.
- Do not mix old and new batteries.
- Only batteries of the same or equivalent type as recommended are to be used.
- Batteries are to be inserted with the correct polarity.
- Exhausted batteries are to be removed from the product.
- The supply terminals are not to be short-circuited.
- Dispose of battery(ies) safely.
- Do not dispose of this product in a fire. The batteries inside may explode or leak.



Protect the environment by not disposing of this product with household waste (2002/96/EC). Check your local authority for recycling advice and facilities.

## 2 TO PLAY

1. LIFT DINO INTO THE UPRIGHT POSITION AND POWER ON.

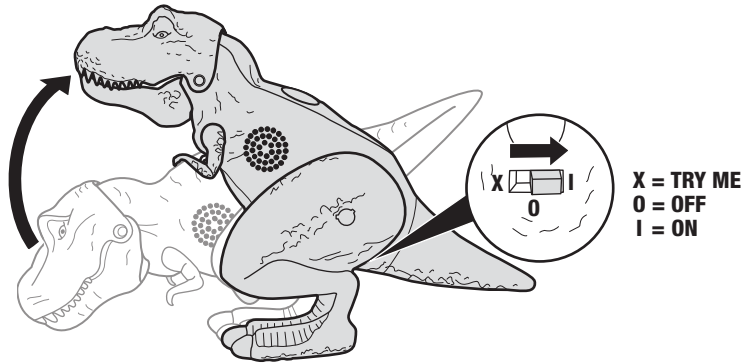

2. PRESS BUTTON FOR ROARING SOUNDS AND LIGHT-UP EYES.

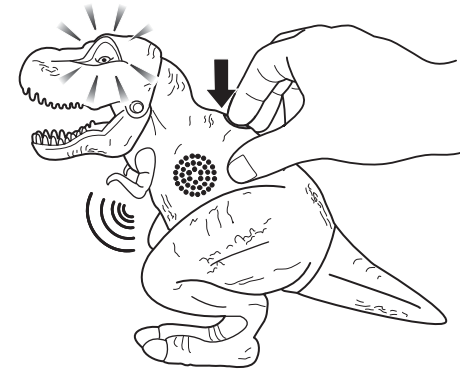

3. LOAD TRANQUILIZER DARTS INTO LAUNCHER.

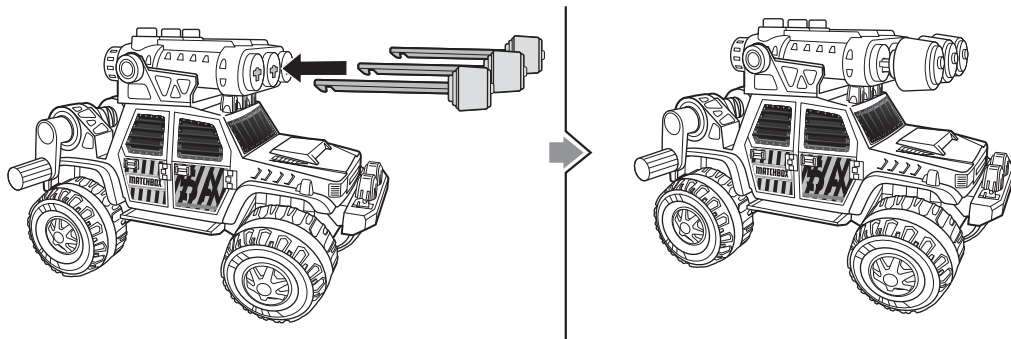

4. TRACK DOWN THE DINO. TAKE AIM AND FIRE!

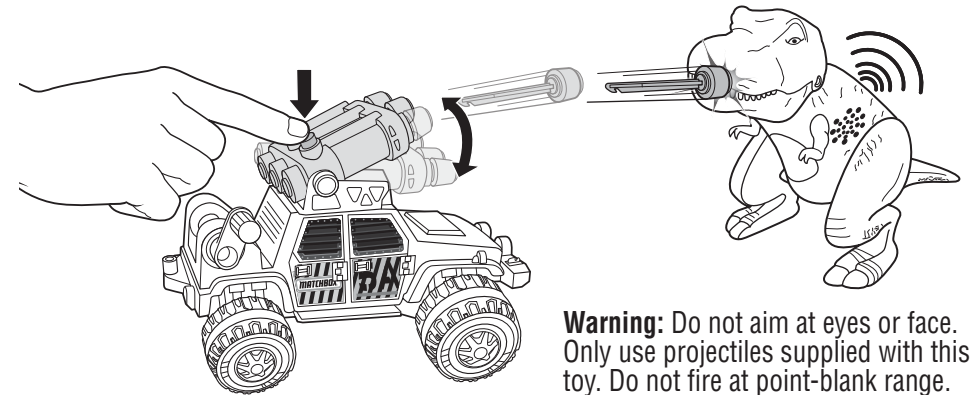

5. HIT CHEST TARGET TO TAKE DOWN THE DINO!

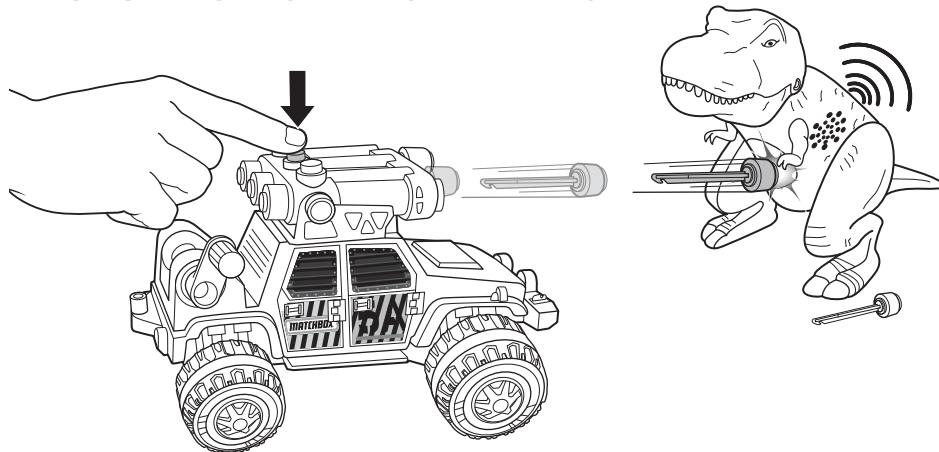

6. DINO FALLS TO SLEEP.

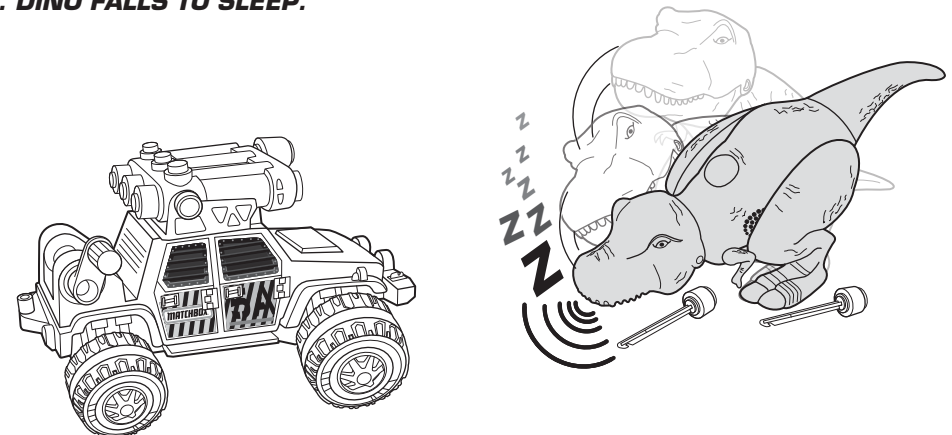

## 2 TO PLAY (CONTD.)

**7. ATTACH TRAILER AND TRUCK TOGETHER. THEN PULL THE HOOK FROM THE WINCH.**

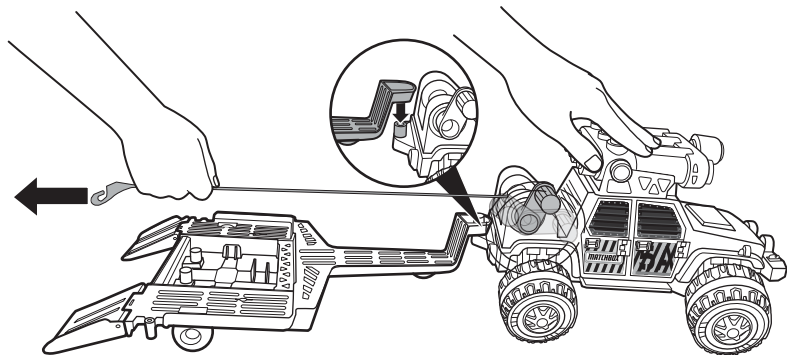

**8. ATTACH HOOK TO COLLAR.**

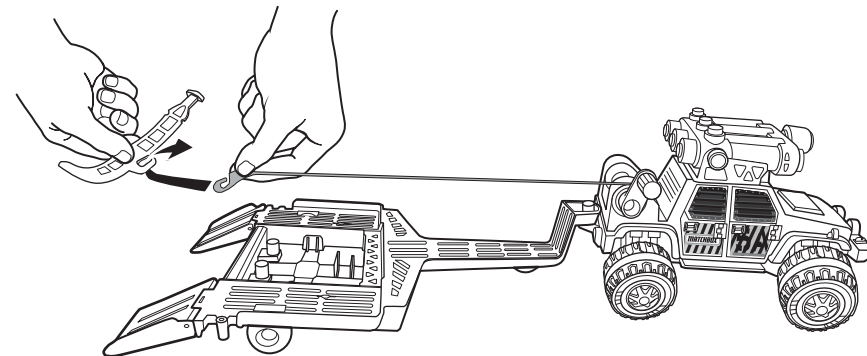

**9. ATTACH COLLAR TO DINO.**

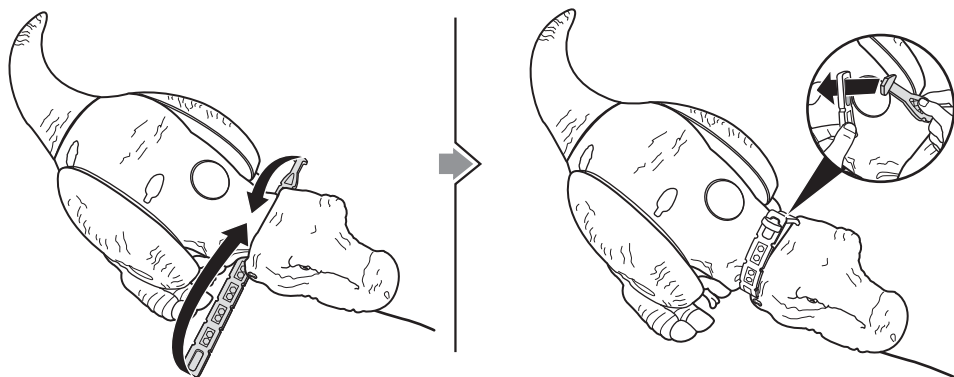

**10. CRANK THE WINCH AND PULL DINO ONTO TRAILER.**

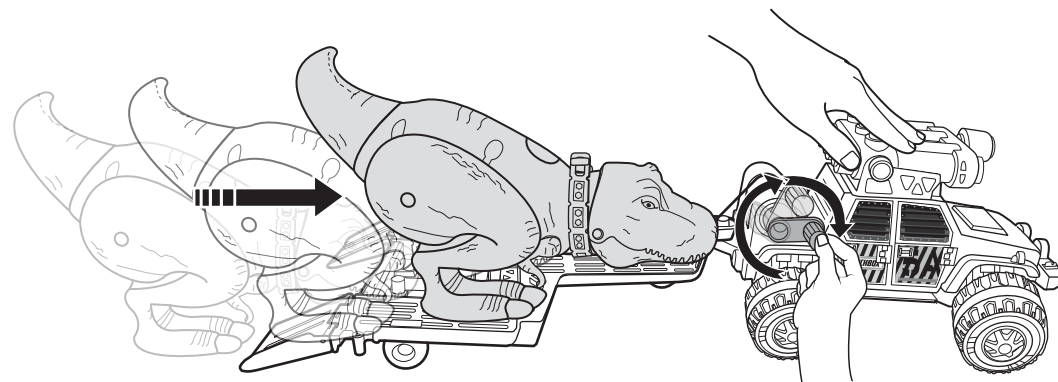

**11. ATTACH CHAIN TO SECURE DINO.**

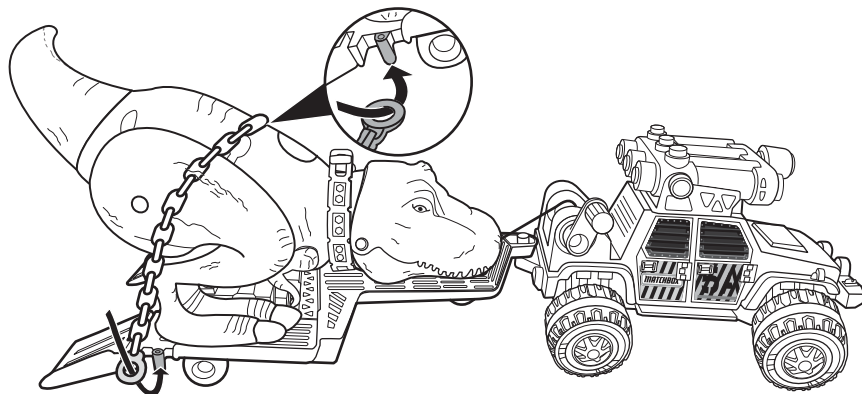

**12. FOLD RAMPS UP AND TAKE DINO AWAY.**

