

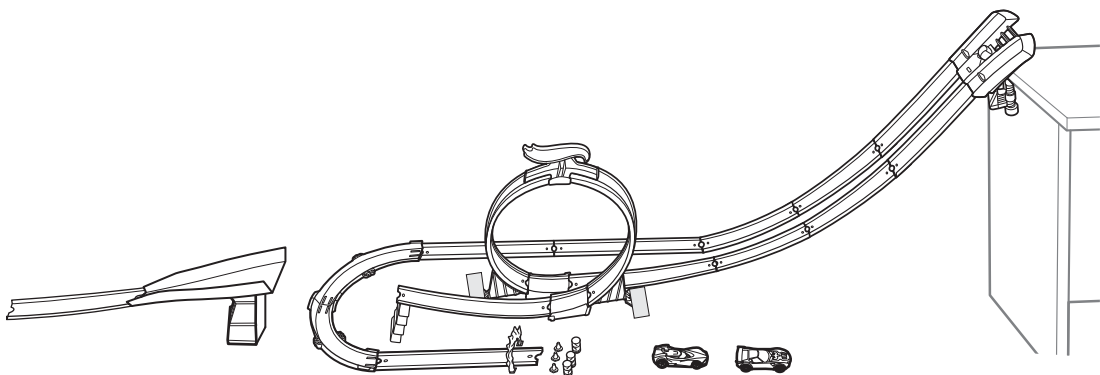

HW WORKSHOP™



WARNING:

CHOKING HAZARD - Small parts.
Not for children under 3 years.

ADVERTENCIA:

PELIGRO DE ASFIXIA. Juguete no recomendado para
menores de 3 años. Contiene piezas pequeñas que podrían
provocar asfixia en caso de ser ingeridas por el niño/a.

ATTENTION:

DANGER D'ÉTOUFFEMENT
- Petits éléments. Ne convient pas
aux enfants de moins de 36 mois.

ADVERTENCIA: Peligro de asfixia. Juguete no recomendado para menores de 3 años, porque contiene piezas pequeñas que podrían provocar asfixia en caso de ser ingeridas o inhaladas por el/la niño/a.



CDJ43-1100311144_Dom

4+

service.mattel.com

HOTWHEELS.COM

PLEASE KEEP THESE INSTRUCTIONS FOR FUTURE REFERENCE AS THEY CONTAIN IMPORTANT INFORMATION. • LEER Y GUARDAR ESTAS INSTRUCCIONES PARA FUTURA REFERENCIA, YA QUE CONTIENEN INFORMACIÓN DE IMPORTANCIA ACERCA DE ESTE PRODUCTO. • CONSERVER CE MODE D'EMPLOI POUR S'Y RÉFÉRER AU BESOIN CAR IL CONTIENT DES INFORMATIONS IMPORTANTES.

LABEL SHEET
HOJA DE CALCOMANÍAS
FEUILLE D'AUTOCOLLANTS



cone x3 can x3

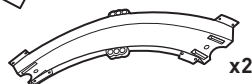
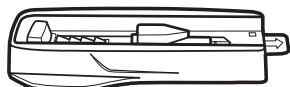
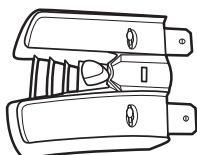
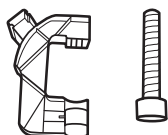

APPLY LABELS • PEGA LAS CALCOMANÍAS
APPLIQUER LES AUTOCOLLANTS

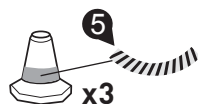
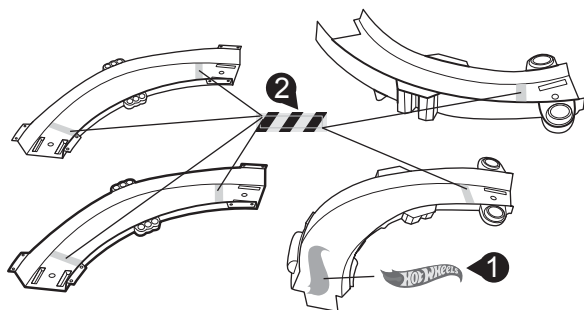
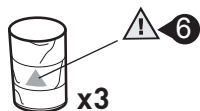
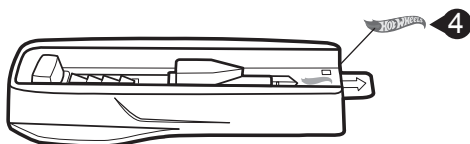
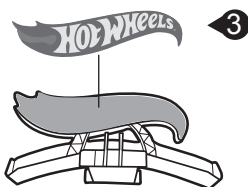

1.

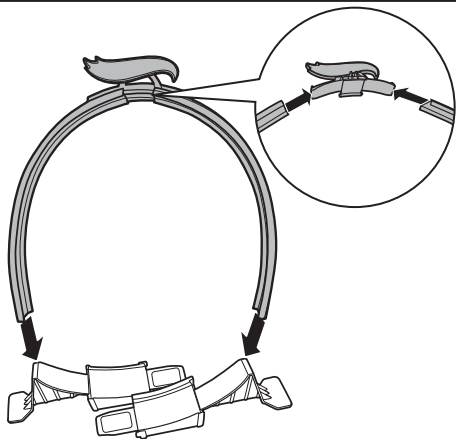

2.

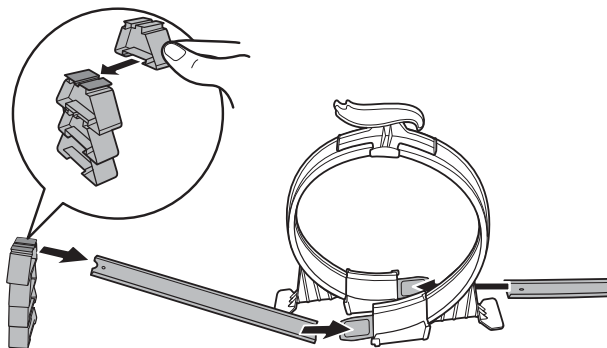

5.

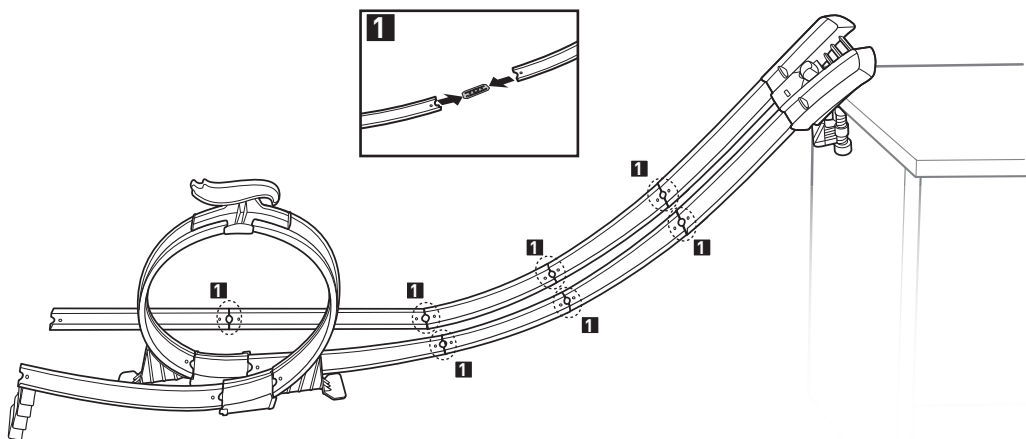

7.

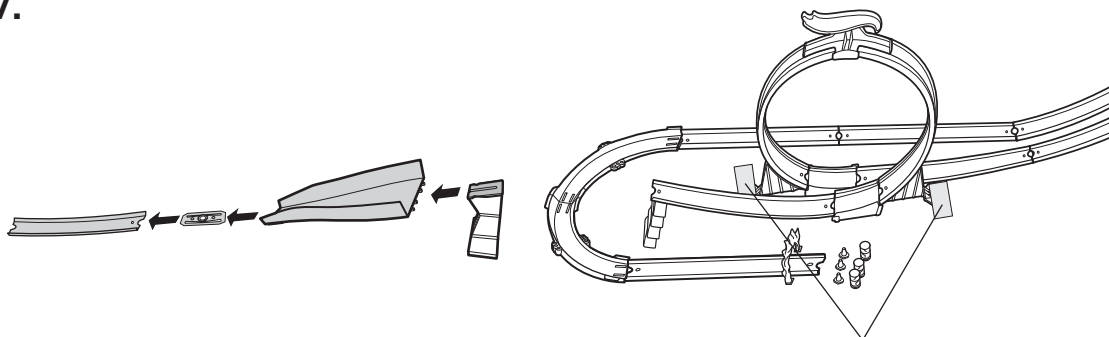

Add tape or books here to stabilize the set.
Añade cinta o libros aquí para estabilizar el set.
Ajouter du ruban adhésif ou des livres pour stabiliser la piste.

3.

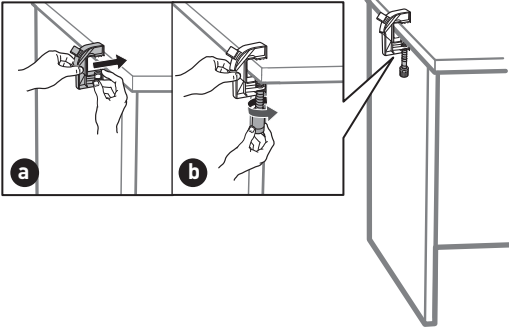

4.

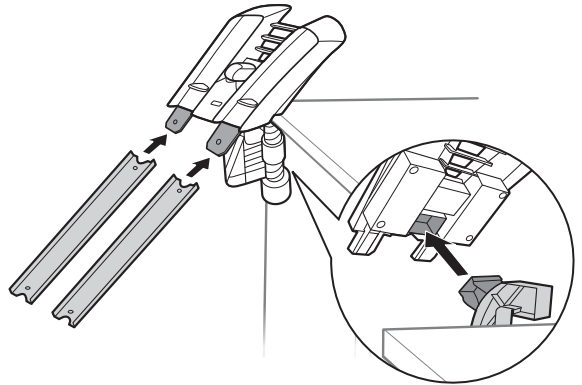

6.

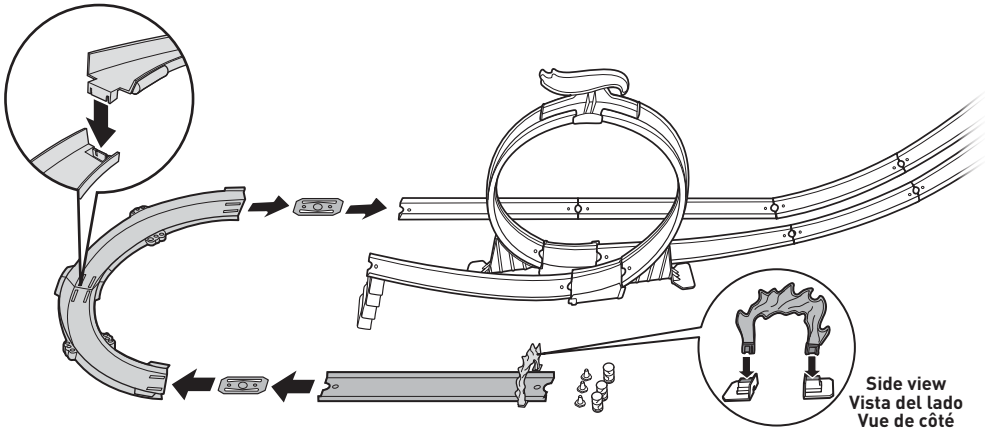

Side view
Vista del lado
Vue de côté

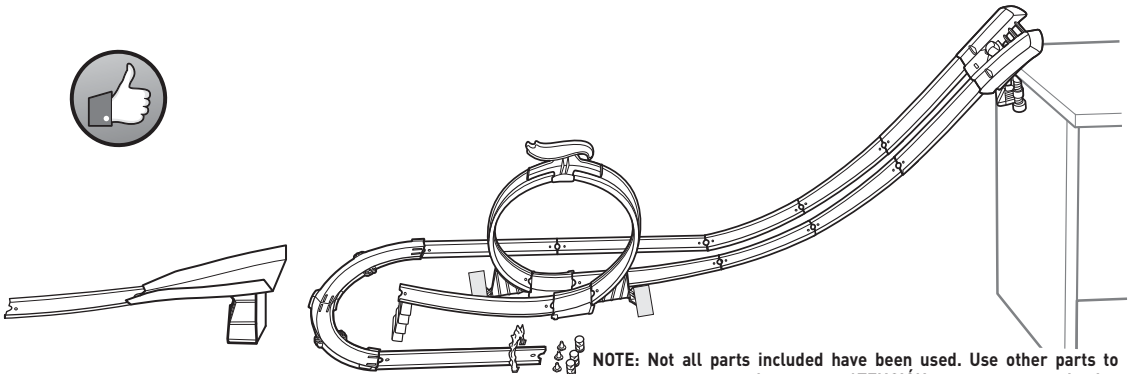

NOTE: Not all parts included have been used. Use other parts to create your own track set-up. • **ATENCIÓN:** no se usaron todas las piezas incluidas. Usa otras piezas para crear tu propia configuración de pista. • **REMARQUE :** Les pièces incluses n'ont pas toutes été utilisées. Utiliser d'autres pièces pour créer sa propre piste.

TO PLAY • PARA JUGAR • POUR JOUER

1. Load vehicles
Pon los vehículos en su lugar
Installer les véhicules.

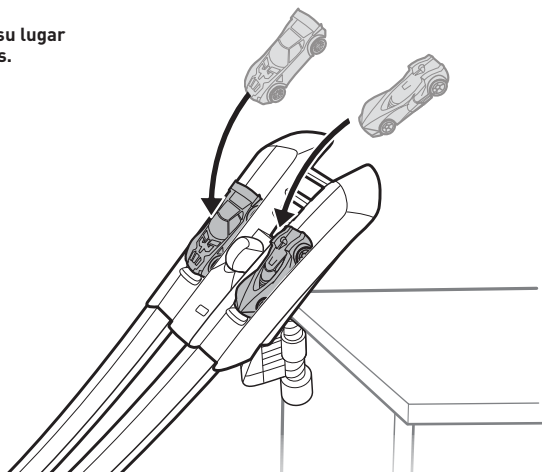

2. Launch vehicles into action!
¡Lanza los vehículos en acción!
Lancer les véhicules sur la piste.

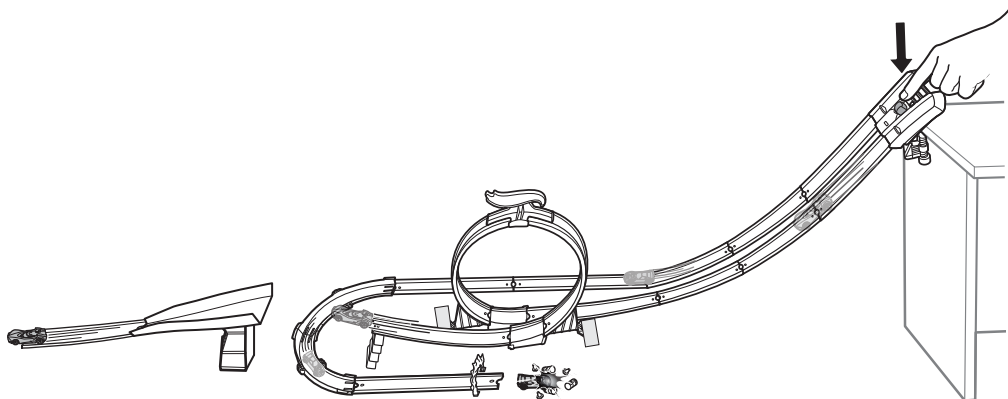

NOT FOR USE WITH SOME HOT WHEELS® VEHICLES.
NO COMPATIBLE CON ALGUNOS VEHÍCULOS HOT WHEELS.
NON COMPATIBLE AVEC CERTAINS VÉHICULES HOT WHEELS.

MORE WAYS TO PLAY • MÁS MANERAS DE JUGAR AUTRES FAÇONS DE JOUER

Try building these set-ups, or create your own!
¡Intenta hacer estas configuraciones o crea tu propia configuración!
Essayer ces configurations. Il est aussi possible de créer sa propre piste!

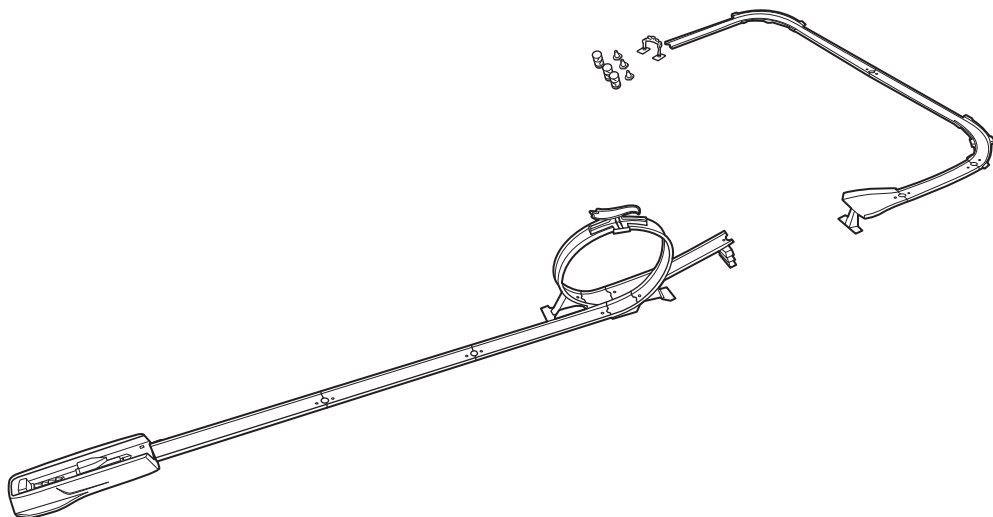
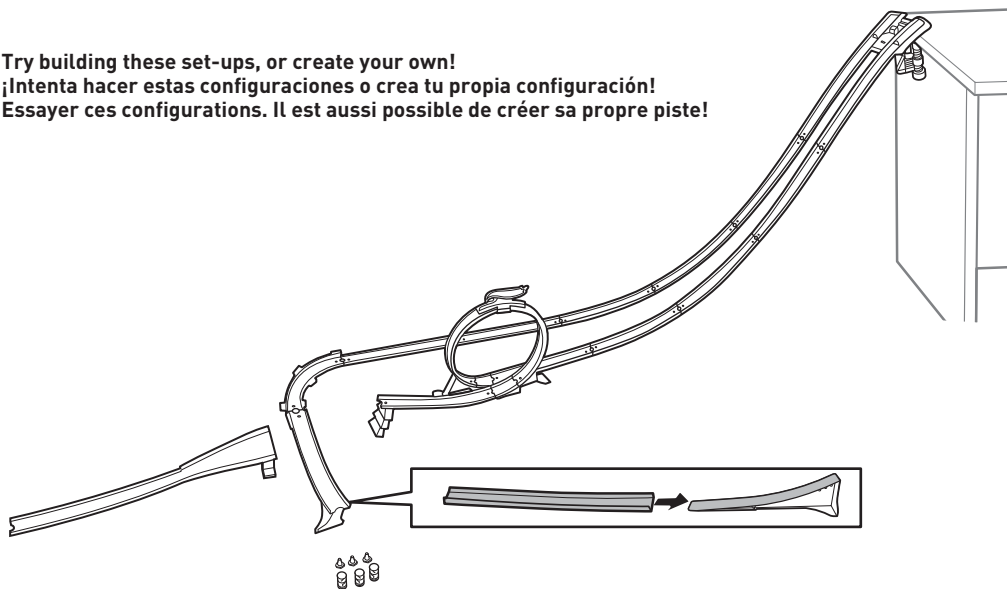

©2014 Mattel. All Rights Reserved. Tous droits réservés. Mattel, Inc. 636 Girard Avenue, East Aurora, NY 14052, U.S.A. Consumer Services 1-800-524-8697. Mattel Canada Inc., Mississauga, Ontario L5R 3W2. You may call us free at / Composez sans frais le 1-800-524-8697. Mattel Australia Pty., Ltd., Richmond, Victoria. 3121. Consumer Advisory Service - 1300 135 312. Mattel East Asia Ltd., Room 503-09, North Tower, World Finance Centre, Harbour City, Tsimshatsui, HK, China. Diimport & Diedarkan Oleh: Mattel Southeast Asia Pte. Ltd., No 19-1, Tower 3 Avenue 7, Bangsar South City, No 8, Jalan Kerinchi, 59200 Kuala Lumpur, Malaysia. Tel: 03-78803817, Fax: 03-78803867. Mattel U.K. Ltd., Vanwall Business Park, Maidenhead SL6 4UB. Importado y distribuido por Mattel de México, S.A. de C.V., Miguel de Cervantes Saavedra No. 193, Pisos 10 y 11, Col. Granada, Delegación Miguel Hidalgo, C.P. 11520, México, D.F. R.F.C. MME-920701-NB3. Tels.: 59-05-51-00 Ext. 5206 o 01-800-463-59-89. Mattel Chile, S.A., Avenida Américo Vespucio 501-B, Quilicura, Santiago. Tel.: 1230-020-6213. Servicio al consumidor Venezuela: Tel.: 0-800-710-2069. Mattel Argentina, S.A., Curupayti 1186, [1607] - Villa Adelina, Buenos Aires. Tel.: 0800-666-3373. Mattel Colombia, S.A., Calle 123#7-07 P.5, Bogotá. Tel.: 01800-710-2069. Mattel Perú, S.A., Av. Juan de Arona # 151, Centro Empresarial Juan de Arona, Torre C, Piso 7, Oficina 704, San Isidro, Lima 27, Perú. RUC: 204258653865. Reg. Importador: 02350-12-JUE-DIGESA. Tel.: 0800-54744. E-mail Latinoamérica: servicio.clientes@mattel.com. Mattel France, Parc de la Cerisaie, 1/3/5 allée des Fleurs, 94263 Fresnes Cedex. N° Cristal 0969 36 99 99 (Numéro non surtaxé) ou www.lesjouetsmattel.fr. Mattel España, S.A., Aribau 200. 08036 Barcelona. cservice.spain@mattel.com Tel: 902203010 <http://www.service.mattel.com/es>.