

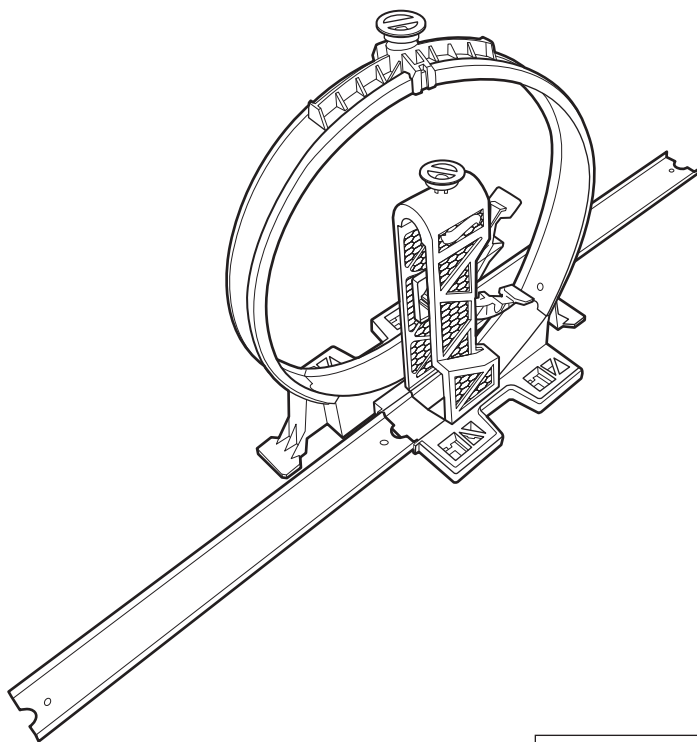

LOOP LAUNCHER



4+

service.mattel.com
HOTWHEELS.COM

 **WARNING:**
CHOKING HAZARD - Small parts.
Not for children under 3 years.



ASST.DNH84
DMH51-0970
1100858693-DOM

PLEASE KEEP THESE INSTRUCTIONS FOR FUTURE REFERENCE AS THEY CONTAIN IMPORTANT INFORMATION.

HERE'S WHAT YOU GET!

PARTS IN THIS SET ARE LABELED TB7.

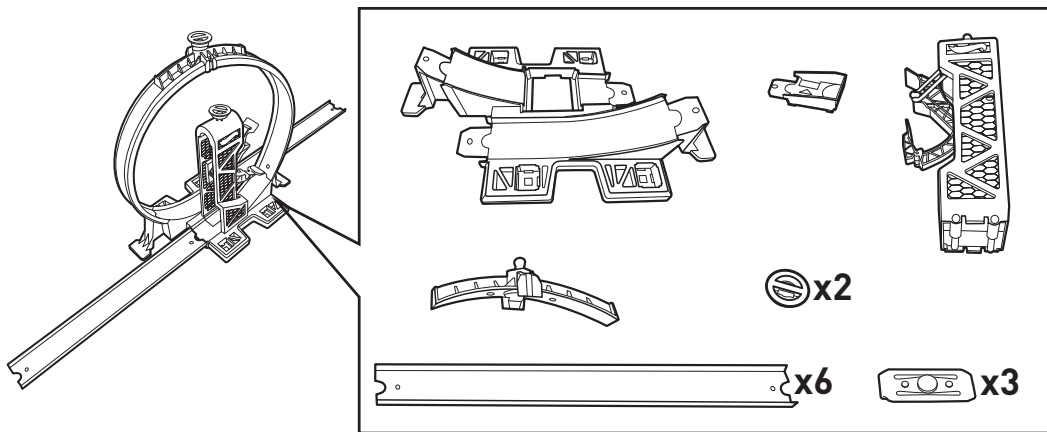

LABEL SHEET



HERE'S HOW YOU START

1. APPLY LABELS.

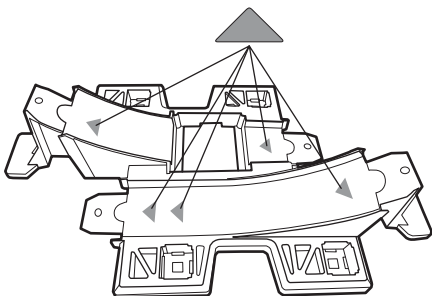

2.

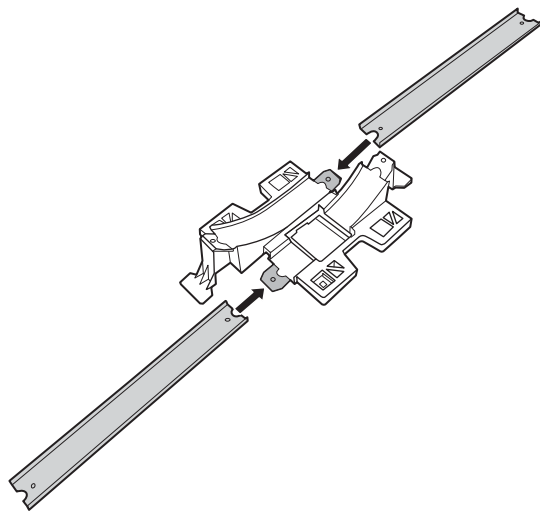

HERE'S HOW YOU START

3.

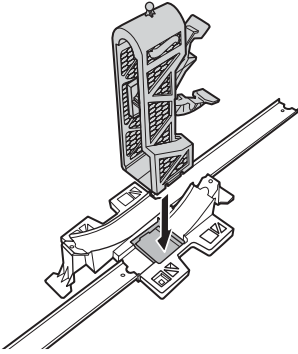

4.

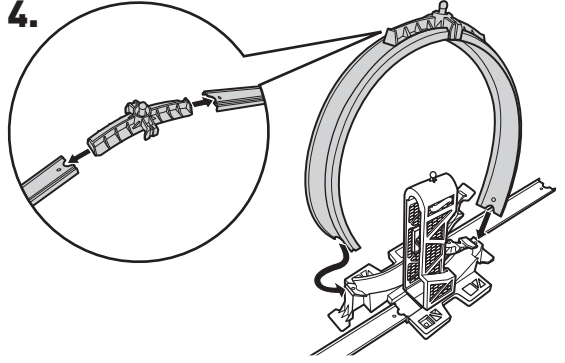

5.

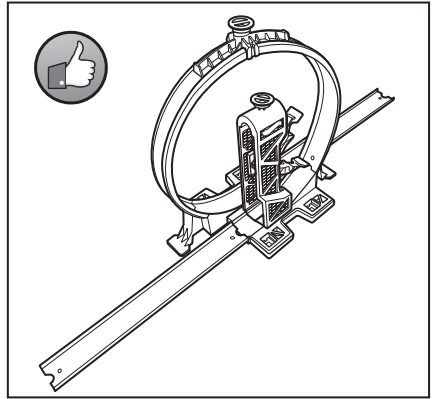
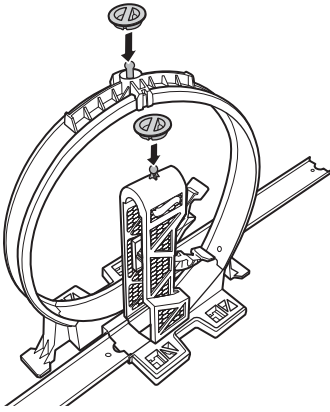

HERE'S HOW IT WORKS!

1. PULL BACK AND LOCK KICKER.

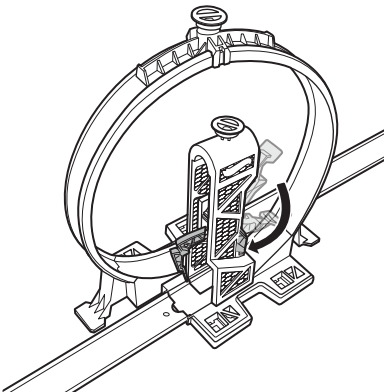

2. RACE INTO THE LOOP FOR A SPEED BOOST!

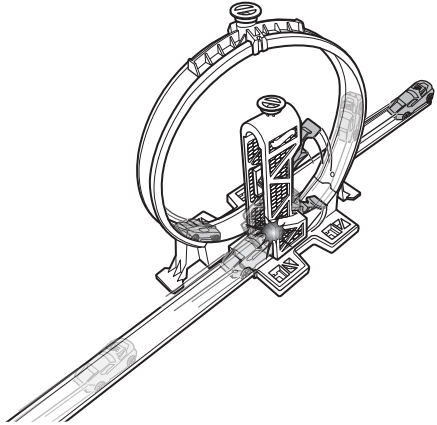

HERE'S WHAT'S COOL!

1.

CONNECT TRACK TO PIVOT POINTS!

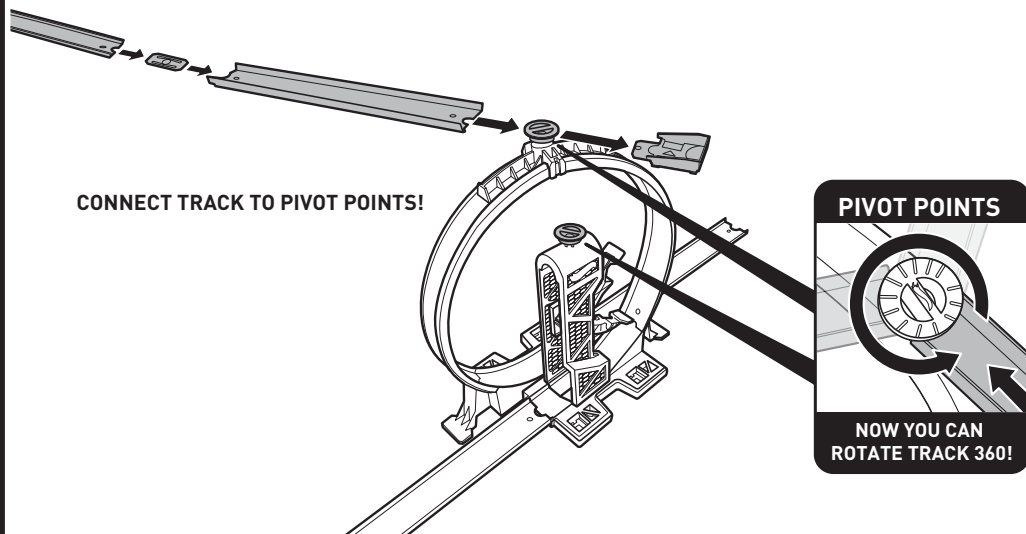

2. NOW GRAB YOUR CAR AND TRY SOME COOL STUNTS!

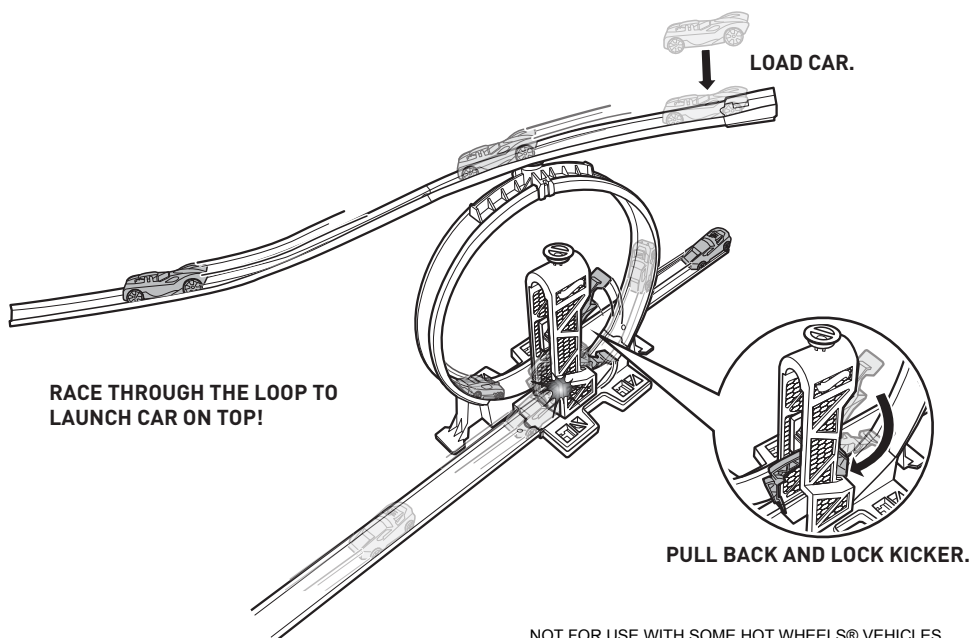

RACE THROUGH THE LOOP TO LAUNCH CAR ON TOP!

PULL BACK AND LOCK KICKER.

NOT FOR USE WITH SOME HOT WHEELS® VEHICLES.
1 VEHICLE INCLUDED. OTHER VEHICLES SOLD SEPARATELY.

WHAT IF.....?

THE KEY TO A RAD STUNT IS IN YOUR HOME ALREADY:

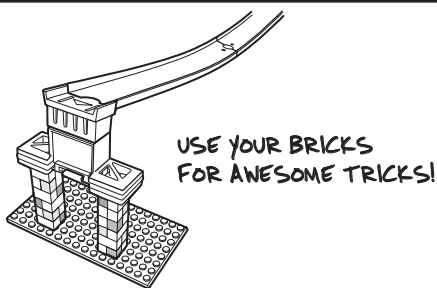
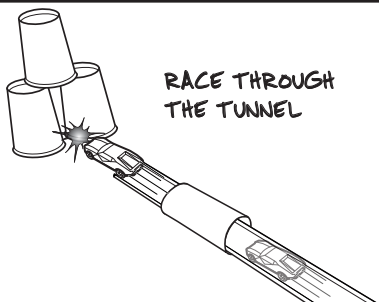
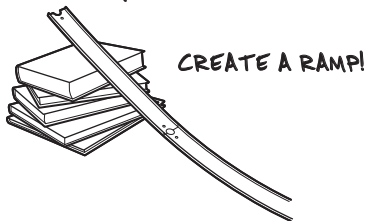

IMAGINE WHAT YOU COULD DO WITH THE TRACK BUILDER SYSTEM!



FOR MORE EPIC TRACK IDEAS VISIT
WWW.HOTWHEELS.COM/TRACKBUILDER

HERE'S WHAT ELSE YOU CAN GET:

ADVERTISEMENT

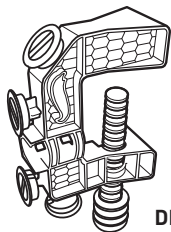

DLF03
CLAMP IT!

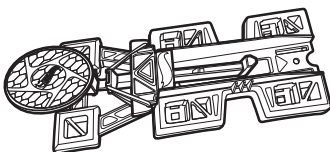

DLF06
LAUNCH IT!



DLF02
HANG IT!

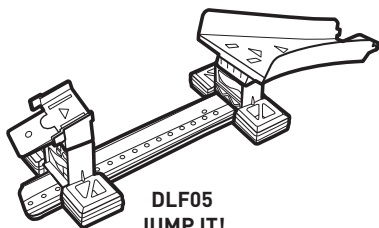

DLF05
JUMP IT!

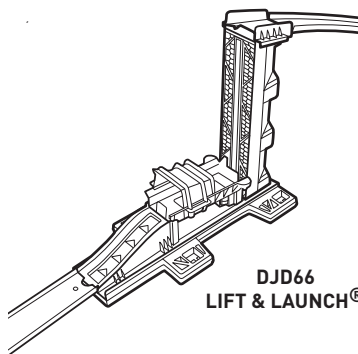

DJD66
LIFT & LAUNCH®

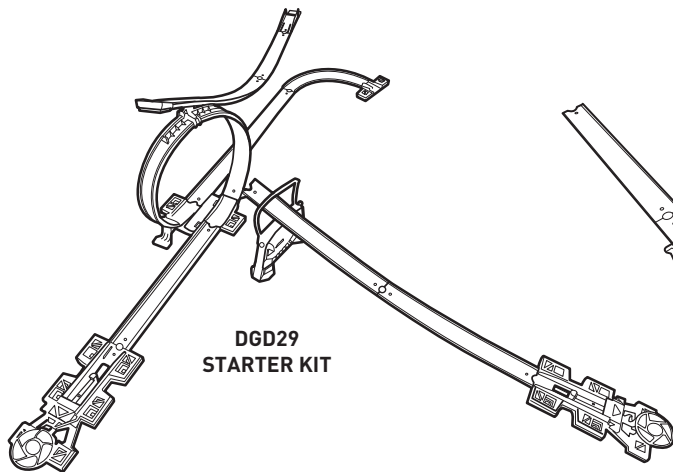

DGD29
STARTER KIT

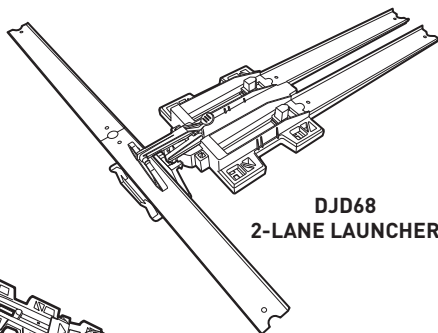

DJD68
2-LANE LAUNCHER

EACH SOLD SEPARATELY, SUBJECT TO AVAILABILITY.