

TRACK & BUILDER SYSTEM

BUILDER'S GUIDE



5+

service.mattel.com

HOTWHEELS.COM



HANG ON TO THIS GUIDE, IT HAS KEY INFORMATION TO BUILD RAD STUNTS!

WARNING:
CHOKING HAZARD - Small parts.
Not for children under 3 years.



DWW96-0970
1101118620-D0M



Featuring

**MEGA
CONSTRUX™**

CONSTRUCTION CRASH KIT

GETTING STARTED!

HERE'S WHAT YOU NEED:

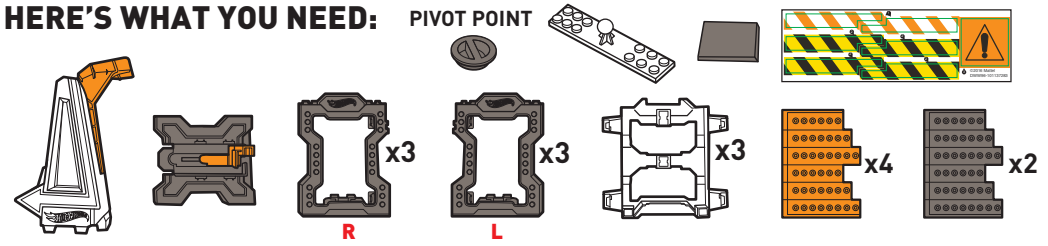

BUILD THESE PIECES BEFORE ASSEMBLING THE TRACKS.

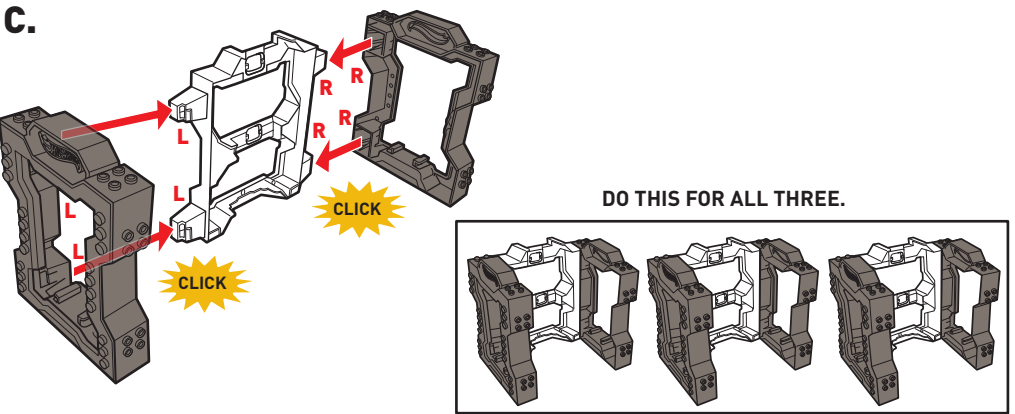
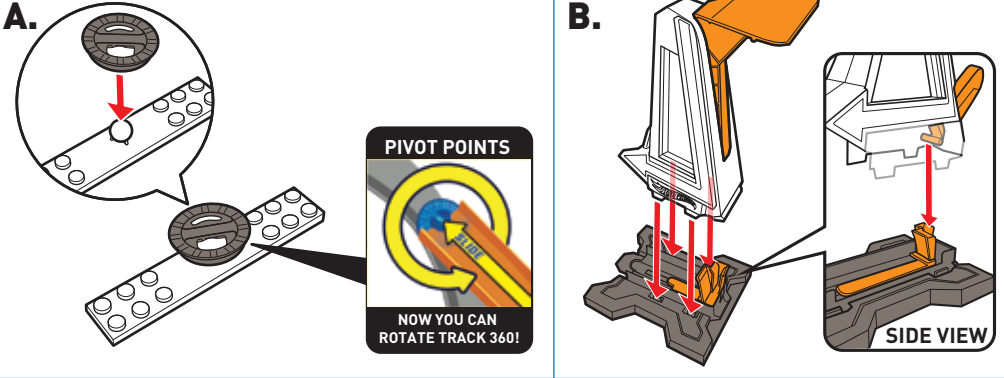

APPLY LABELS

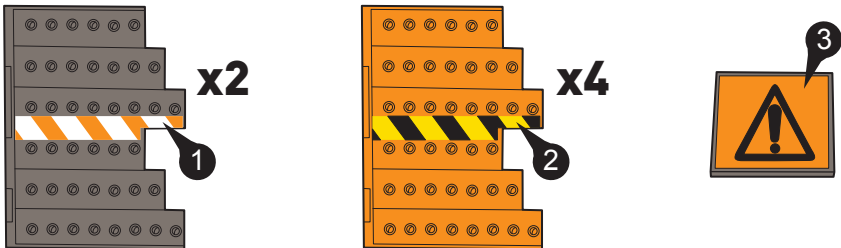

CONGRATULATIONS. You just gained access to the unlimited world of Track Builder and now YOU are in the driving seat. Create your own outrageous stunts, experiment with speed and Keep challenging yourself. Are you ready to get your wheels turning? Grab your car and go.....MAKE IT EPIC™!

LOOP 'N TOWER SMASH

INSTRUCTIONS ON PAGE 4

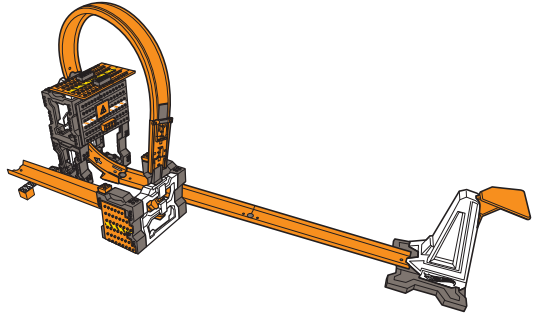

TOWER TARGET

INSTRUCTIONS ON PAGE 8

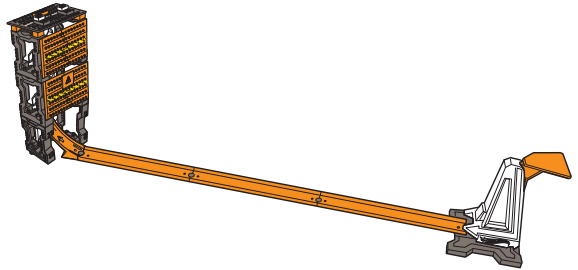

CRASH ZONE

INSTRUCTIONS ON PAGE 12

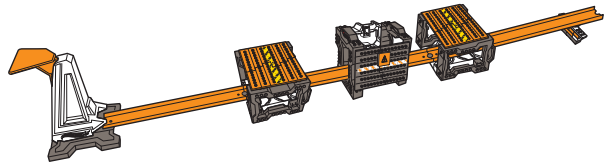

LANEWAY SMASH

INSTRUCTIONS ON PAGE 15

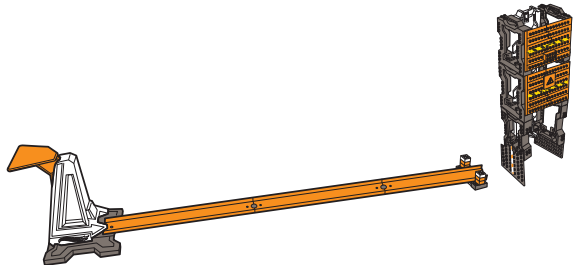

COLORS AND DECORATIONS MAY VARY.
NOT FOR USE WITH SOME HOT WHEELS® VEHICLES.
INCLUDES 1 VEHICLE. ADDITIONAL VEHICLES SOLD SEPARATELY.



PARENTS: FOR EPIC TRACK IDEAS, HOW-TO VIDEOS AND AWESOME ENTERTAINMENT, CHECK OUT THE HOT WHEELS® YOUTUBE CHANNEL!
WWW.YOUTUBE.COM/HOTWHEELS

YouTube

LOOP 'N TOWER SMASH

HERE'S WHAT YOU NEED:

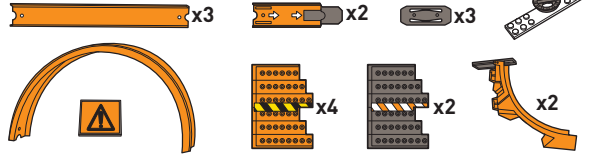
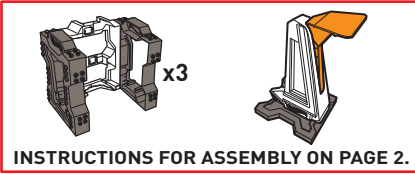
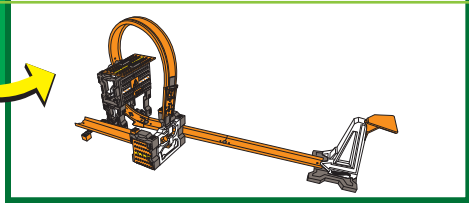

1.

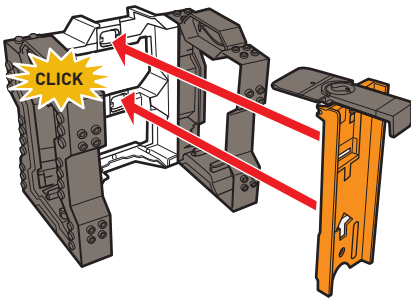

2.

ENSURE THE HOT WHEELS® LOGO IS FACING UPRIGHT.

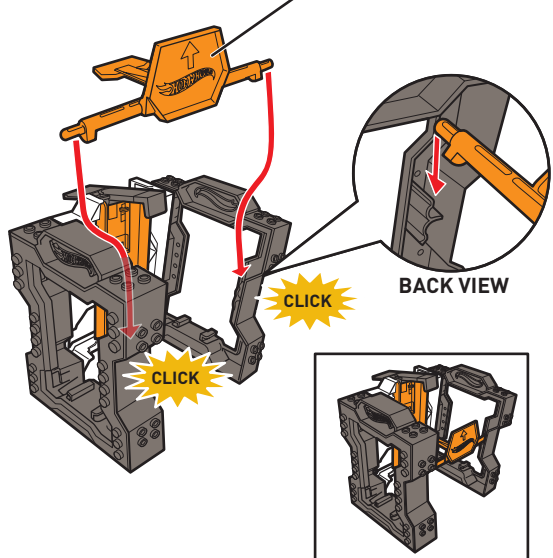

3.

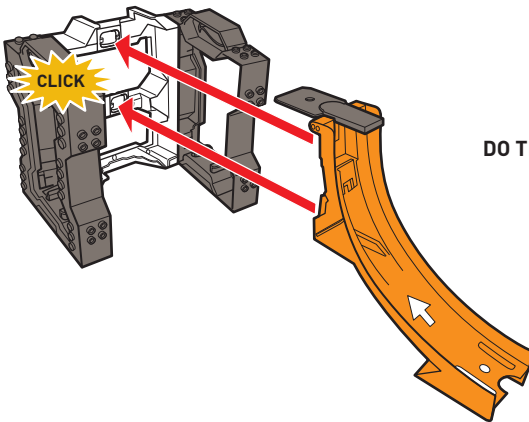

DO THIS TWICE.

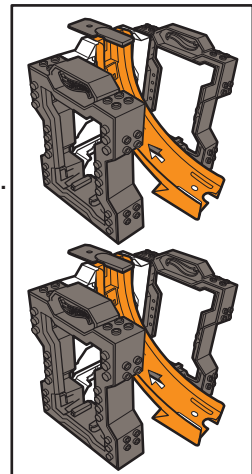

4.

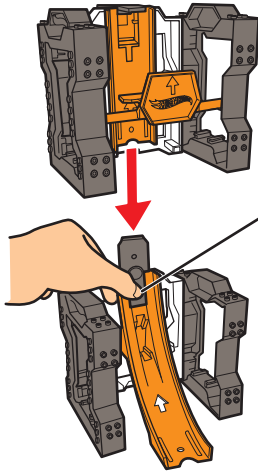

PUSH CONNECTOR UP & ATTACH.

5.

PRESS FIRMLY TO CLICK INTO PLACE.

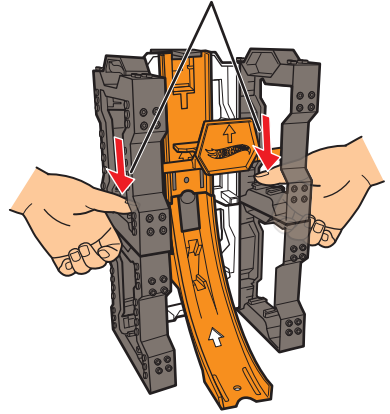

6.

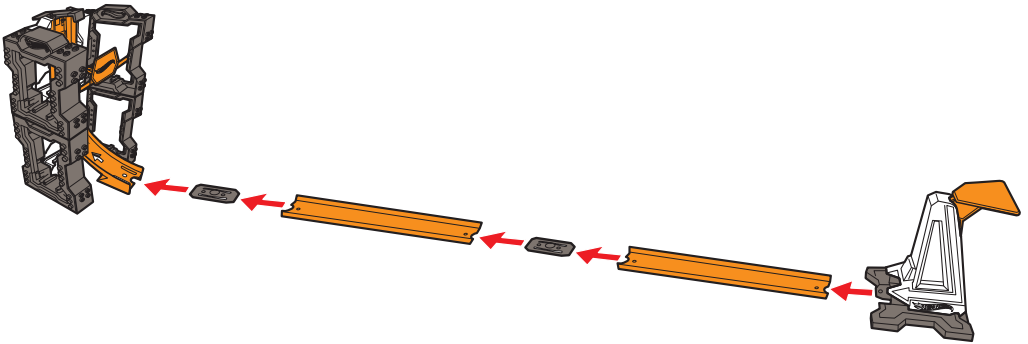

7.

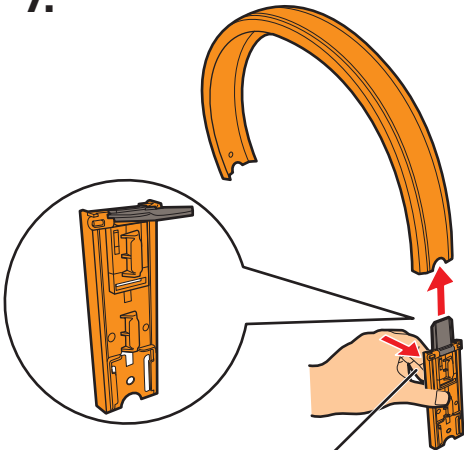

PUSH CONNECTOR UP & ATTACH.

8.

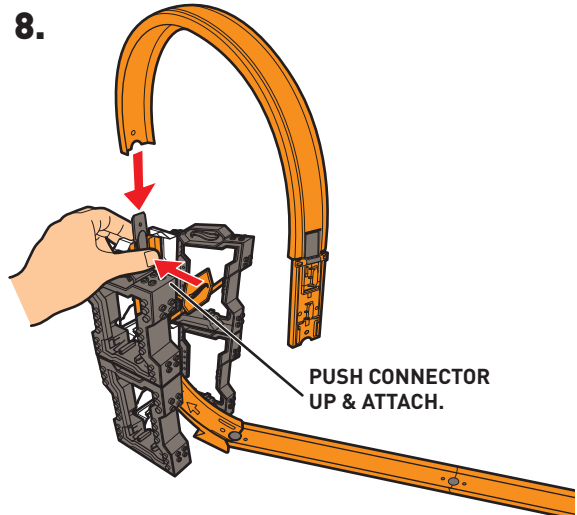

PUSH CONNECTOR UP & ATTACH.

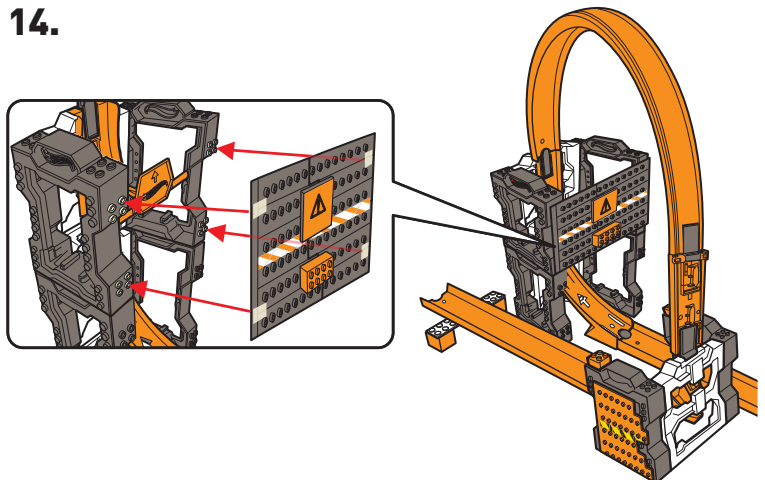
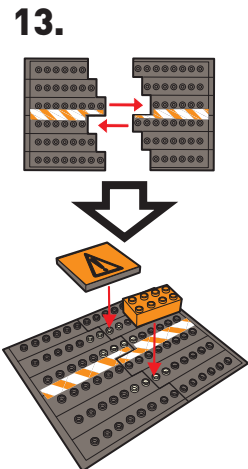
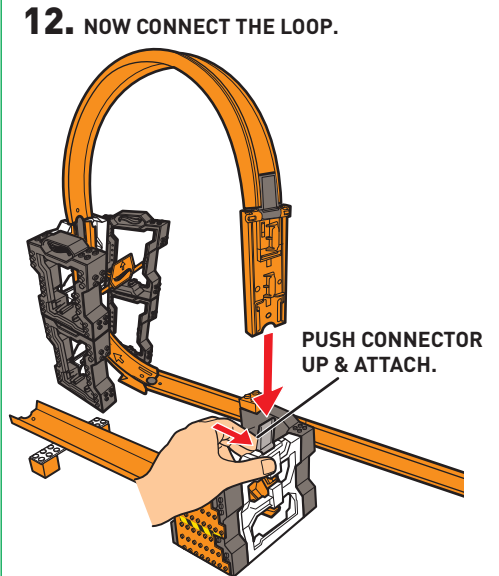
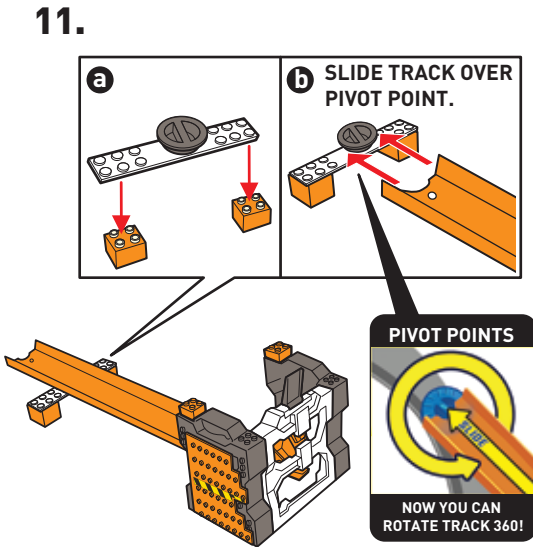
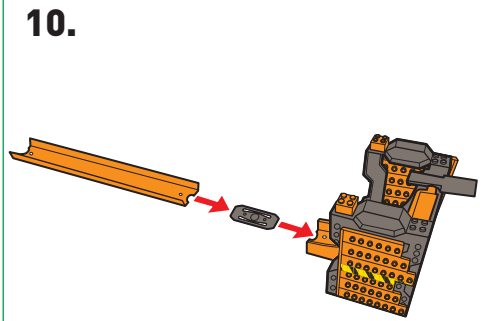
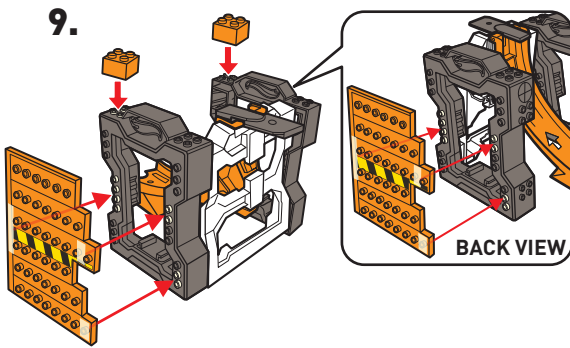

15.

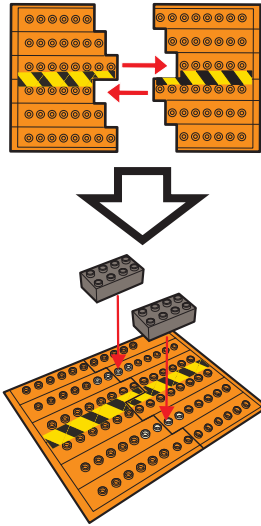

16.

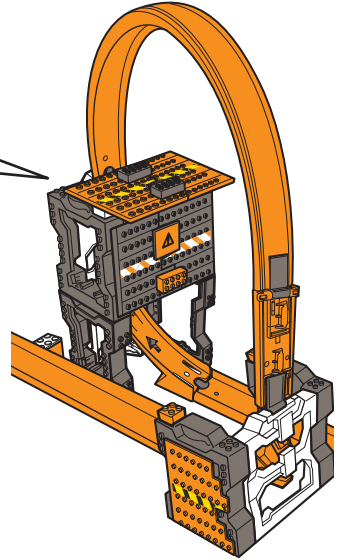
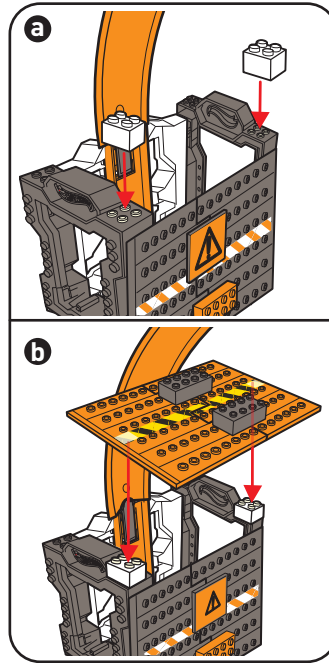

NOW GRAB YOUR CAR AND GO!



EXPERIMENT WITH POWER!
HOW HARD DO YOU NEED TO HIT THE LAUNCHER?

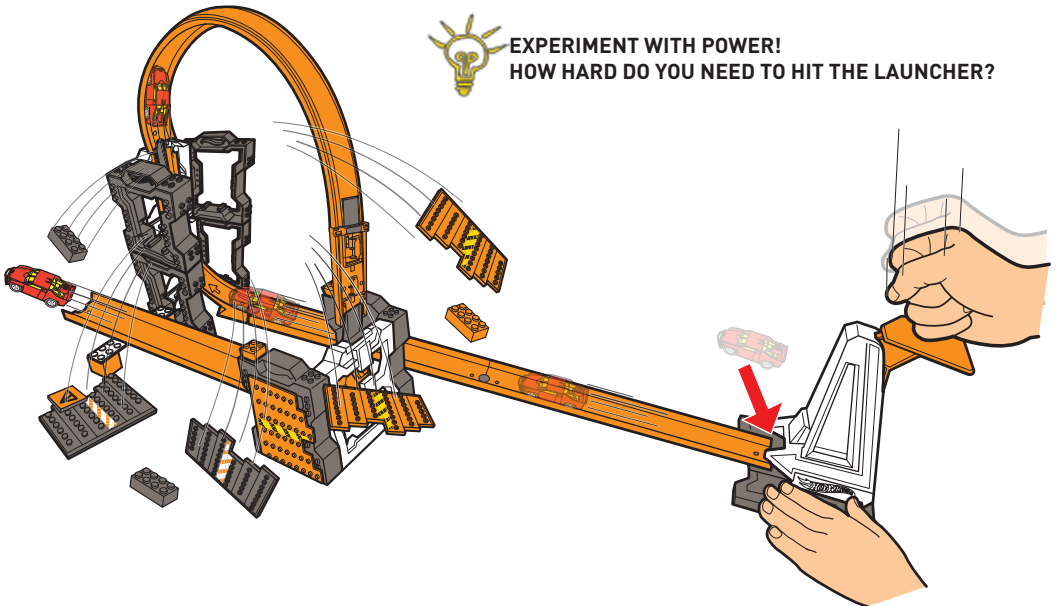

TOWER TARGET

HERE'S WHAT YOU NEED:

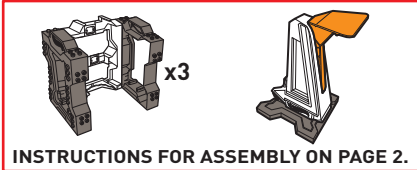
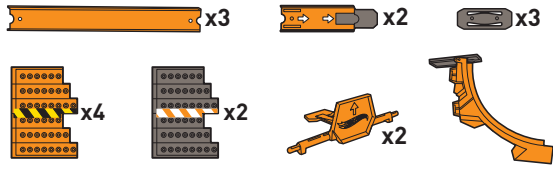
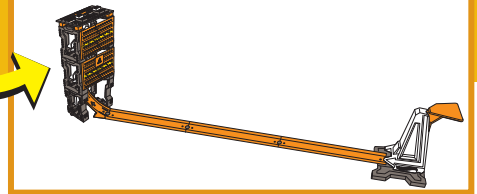

1.

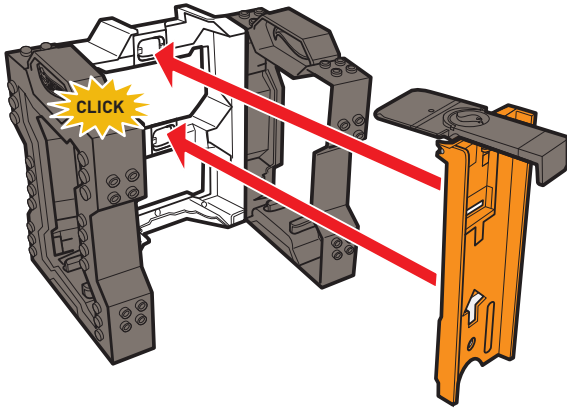

DO THIS TWICE.

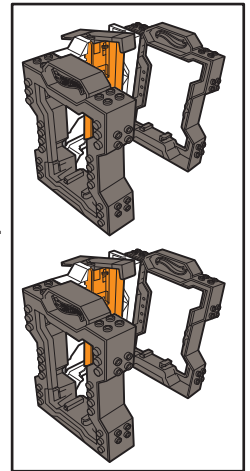

2.

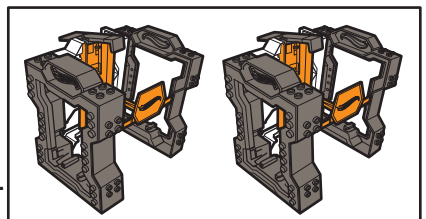
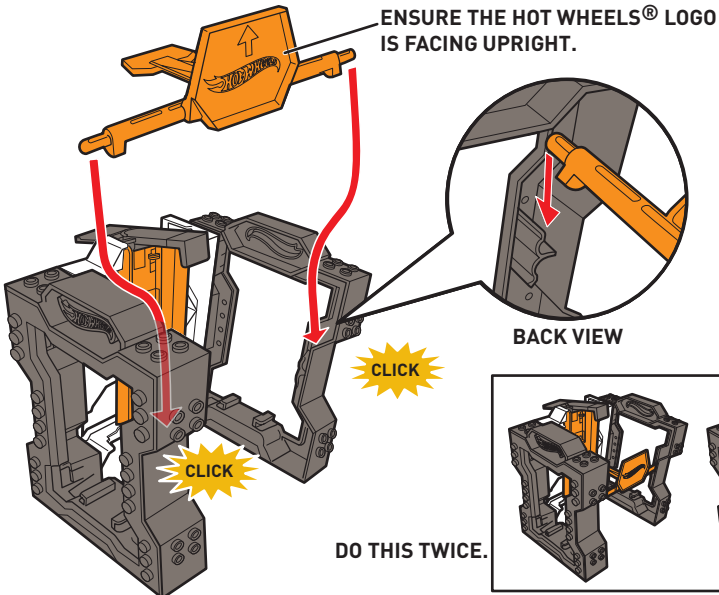

3.

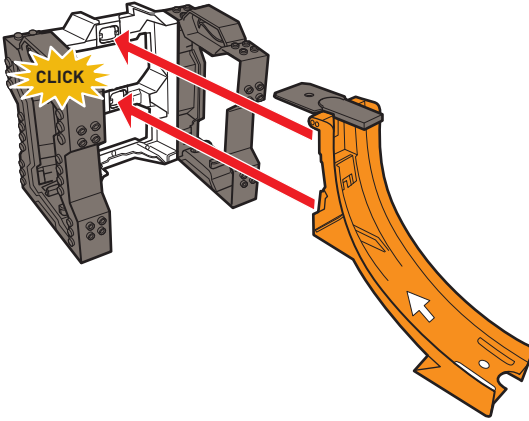

4.

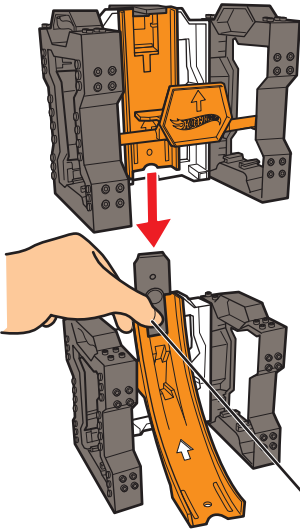

5. NOW ATTACH THE THIRD LEVEL.

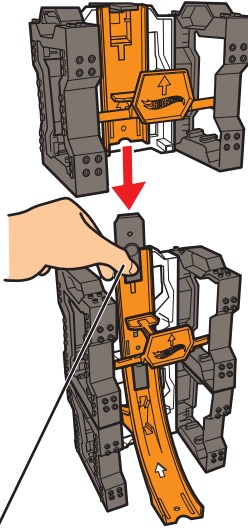

PUSH CONNECTOR UP & ATTACH.

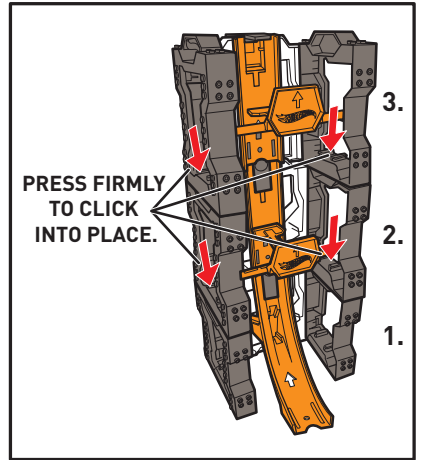

6.

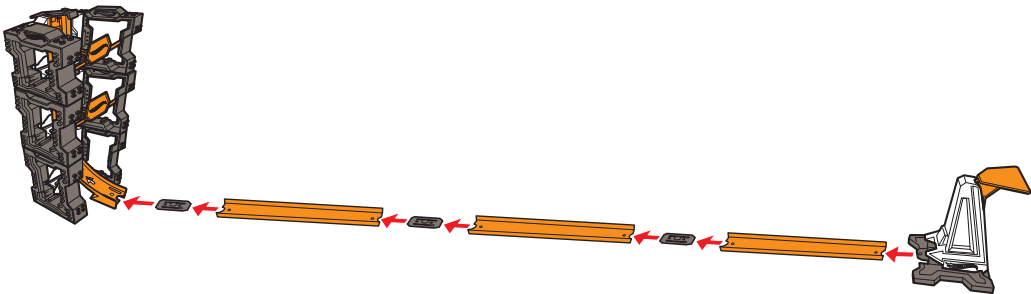

7.

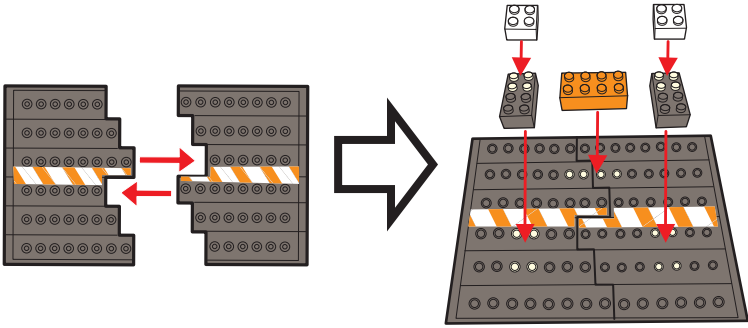

8.

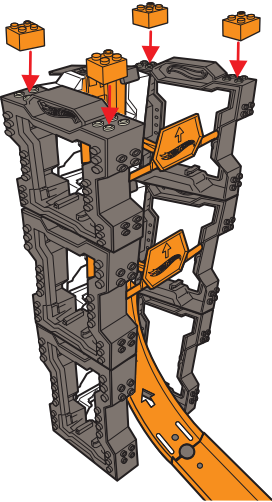

9.

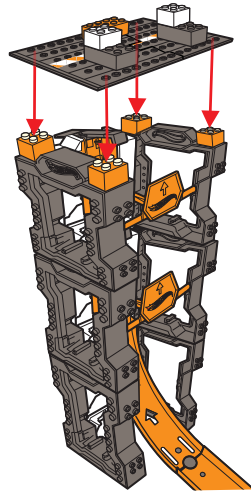

10.

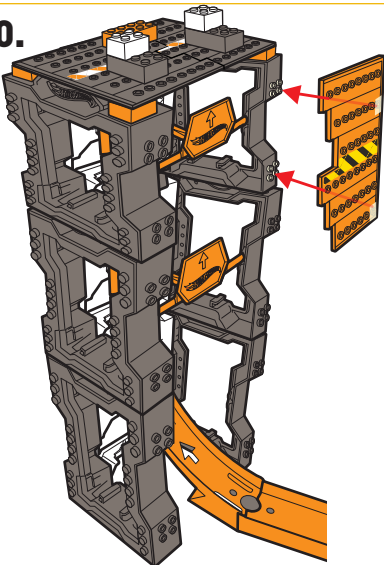

11.

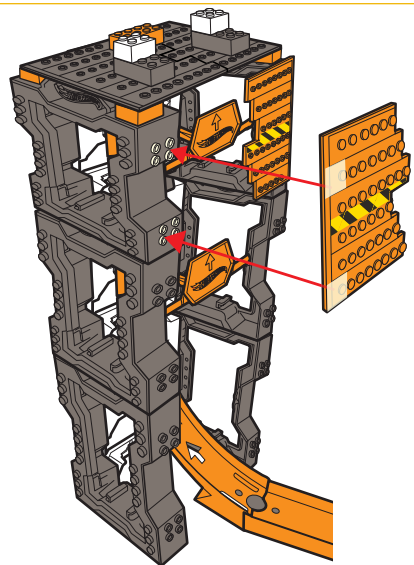

12.

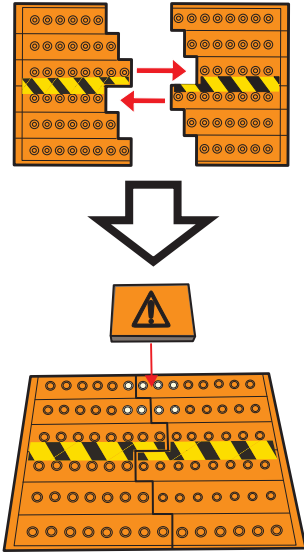

13.

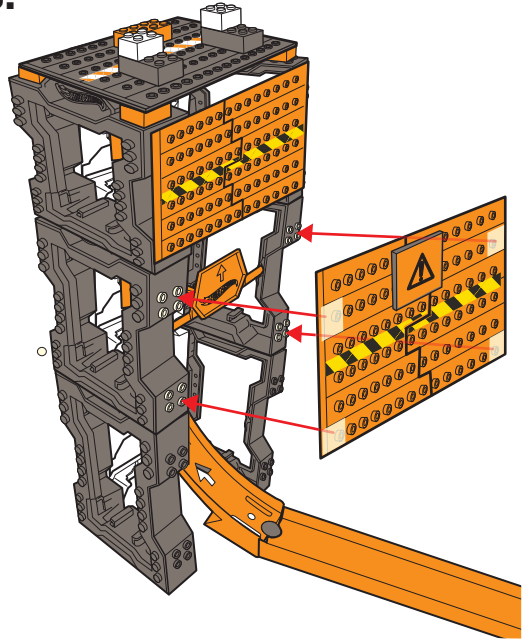

NOW GRAB YOUR CAR AND GO!

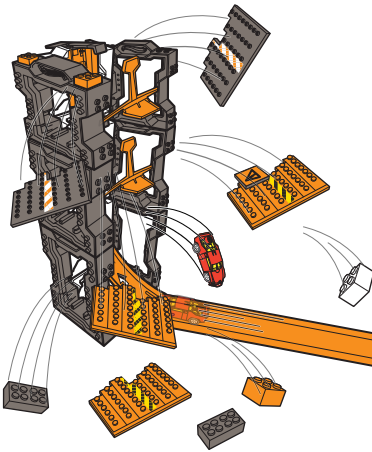

EXPERIMENT WITH HEIGHT!
HOW HIGH CAN YOU JUMP?

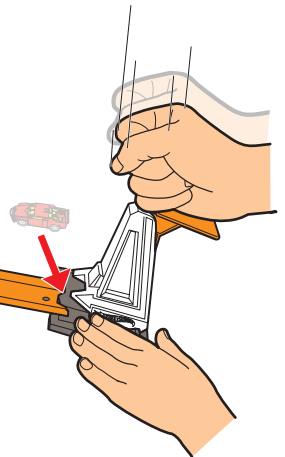

CRASH ZONE

HERE'S WHAT YOU NEED:

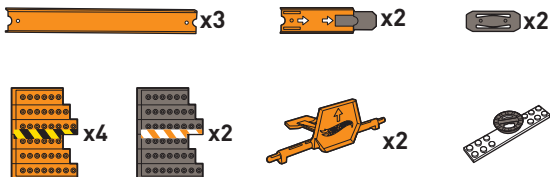
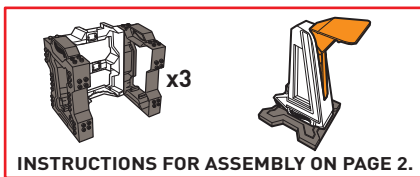
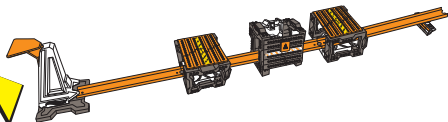

1.

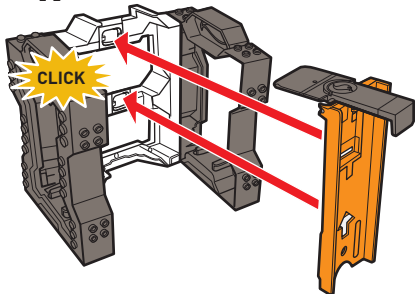

DO THIS TWICE.

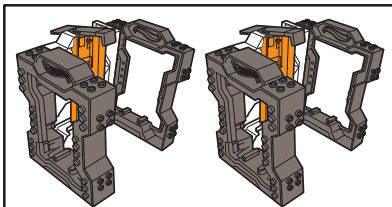

2.

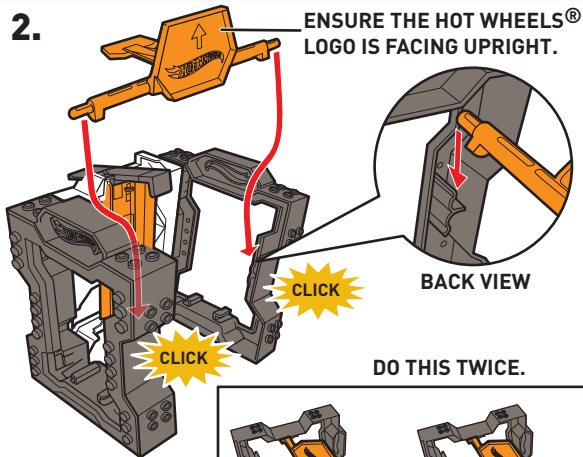

DO THIS TWICE.

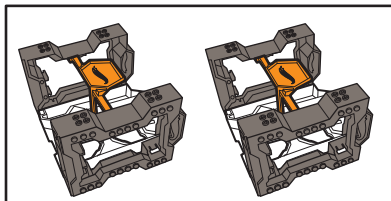

3.

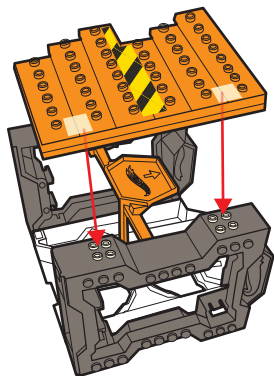

DO THIS TWICE.

4.

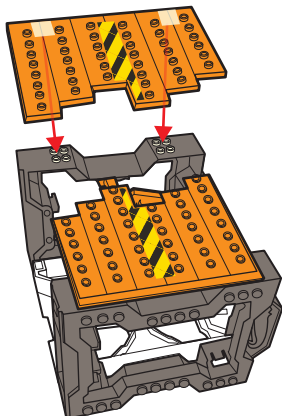

DO THIS TWICE.

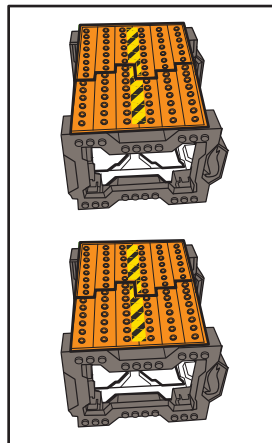

5. INSERT TRACK UNDER THE TABS AND SLIDE TRACK THROUGH.

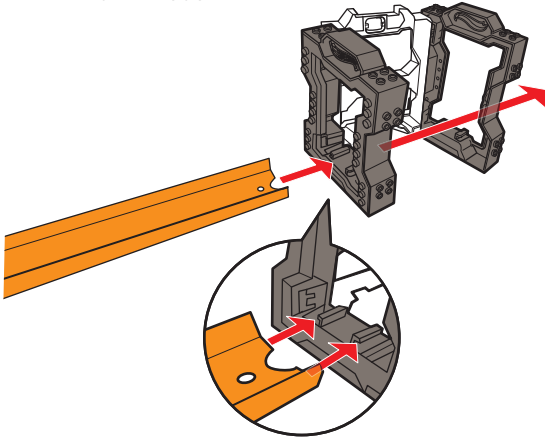

6.

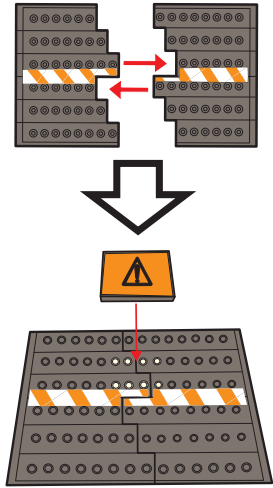

7.

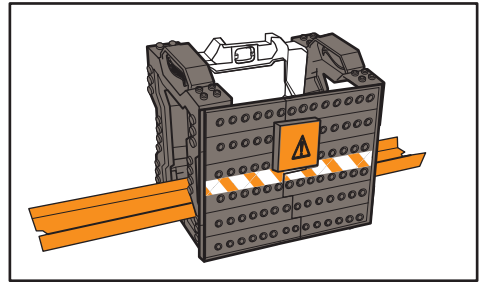
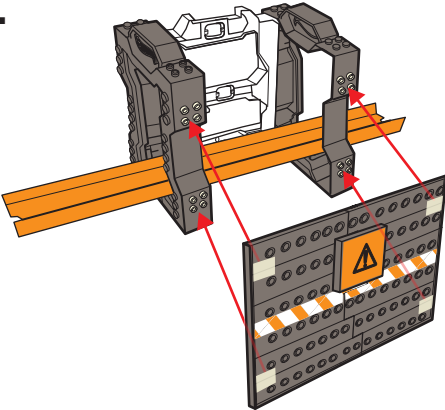

8.

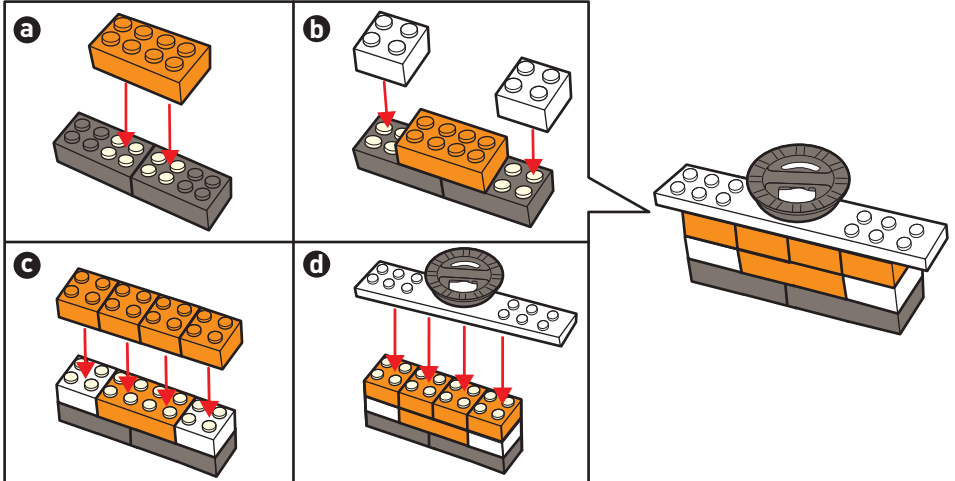

9.

SLIDE TRACK OVER
PIVOT POINT.

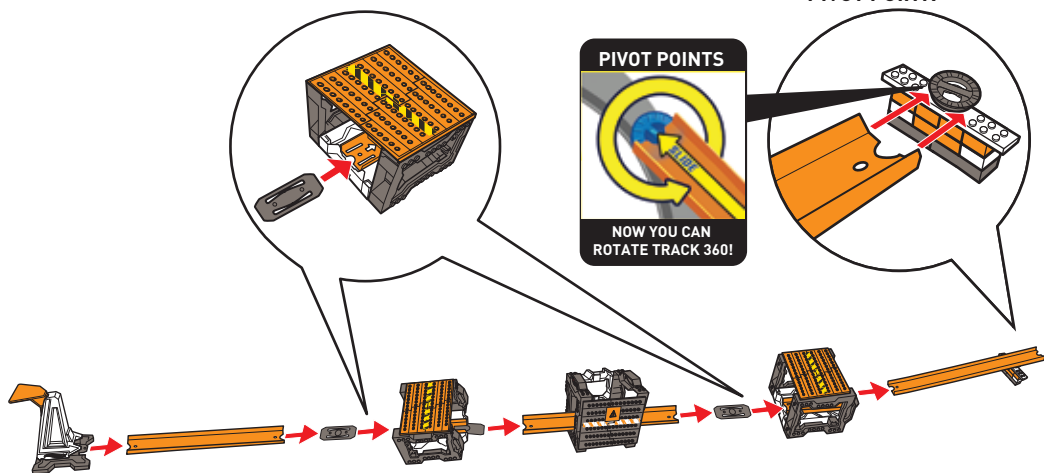

NOW GRAB YOUR CAR AND GO!



EXPERIMENT WITH DISTANCE!
HOW FAR CAN YOU CRASH?

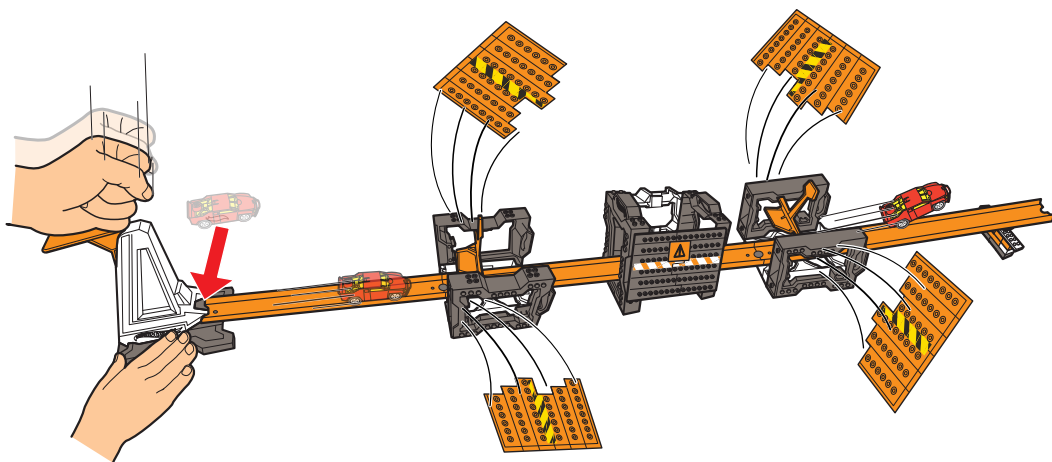

LANEWAY SMASH

HERE'S WHAT YOU NEED:

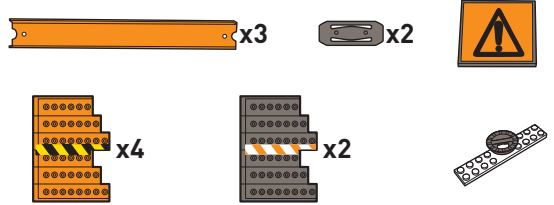
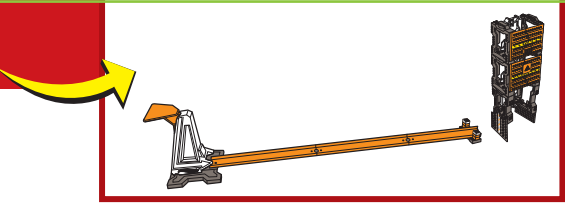
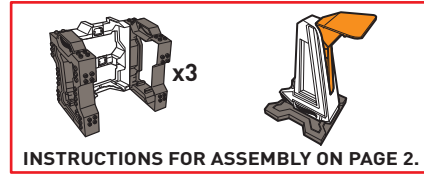

1.

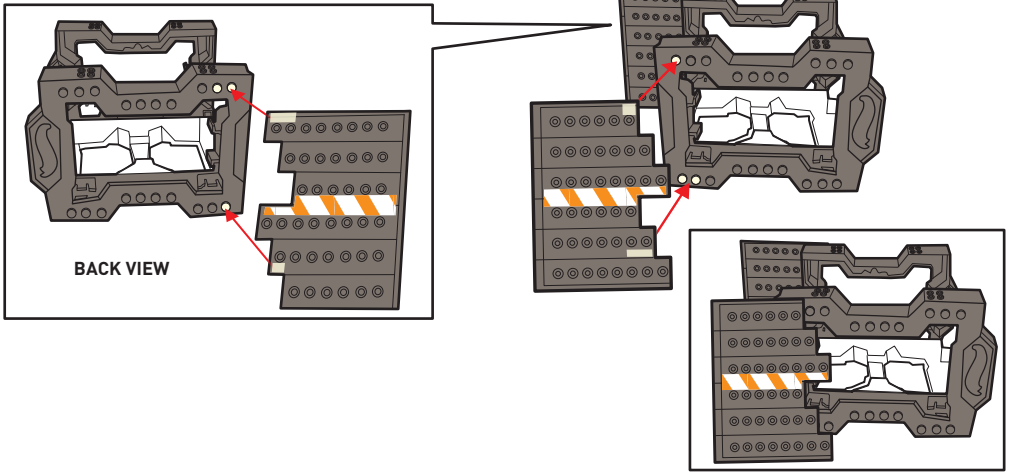

2.

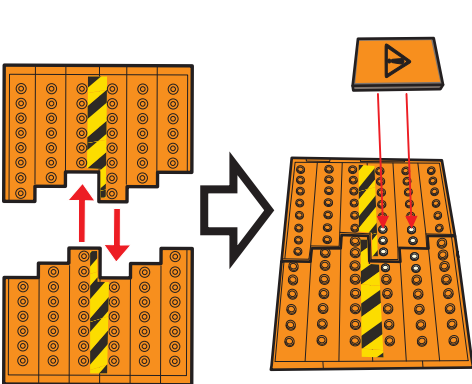

3.

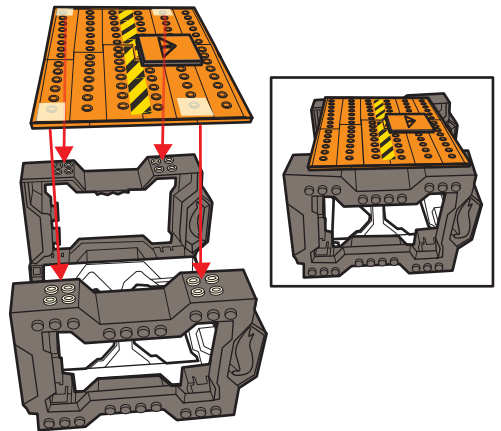

4.

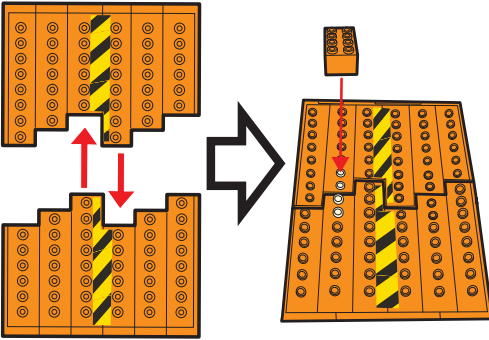

5.

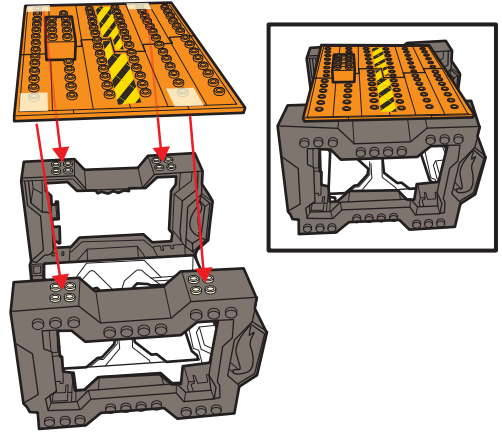

6. COMBINE THE PIECES TO MAKE A TOWER.

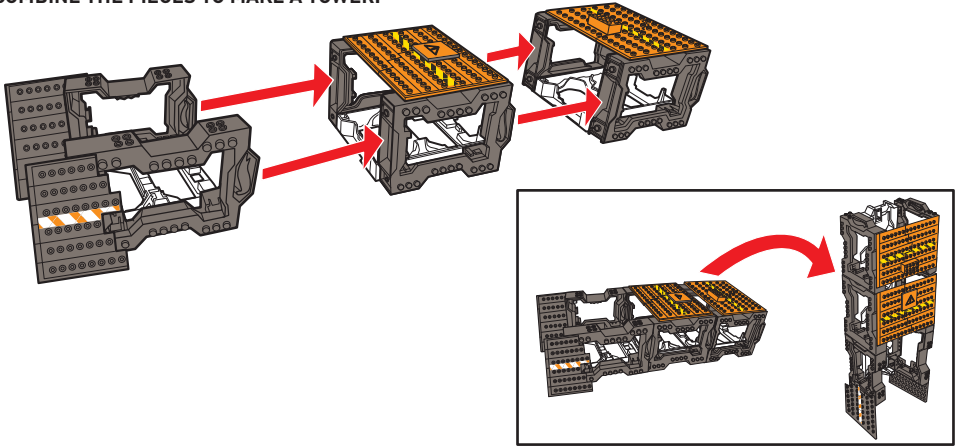

7.

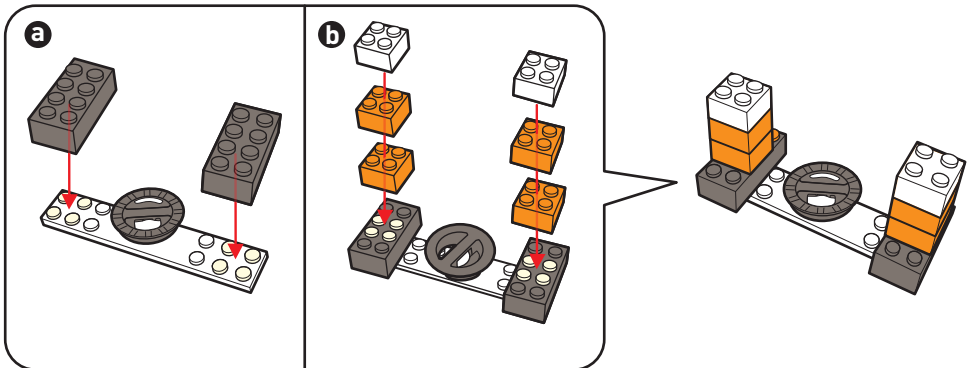

8.

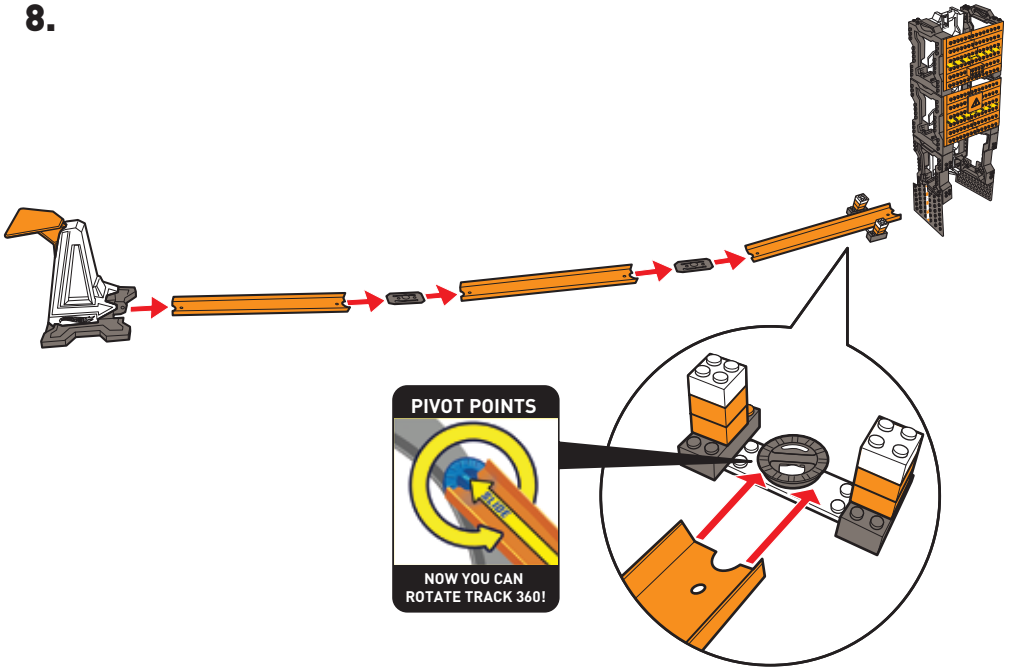

SLIDE TRACK OVER PIVOT POINT.

NOW GRAB YOUR CAR AND GO!



EXPERIMENT WITH SPEED!
HOW FAST DO YOU NEED TO GO TO SMASH THE TOWER?



NOW THAT'S WHAT I CALL A HOT WHEELS® HACK!

SEE INSIDE THE BOX AND USE THE 8 INCLUDED CARDBOARD PANELS TO BUILD OTHER COOL STUNTS!

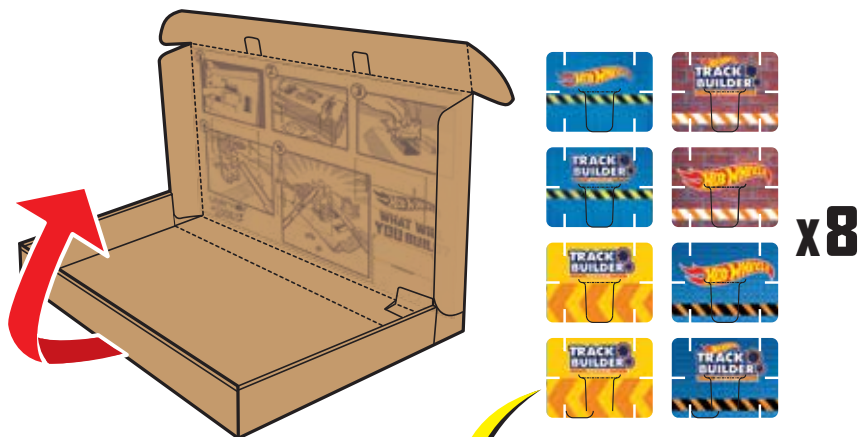

USE THE PACKAGE FOR STUNTS!

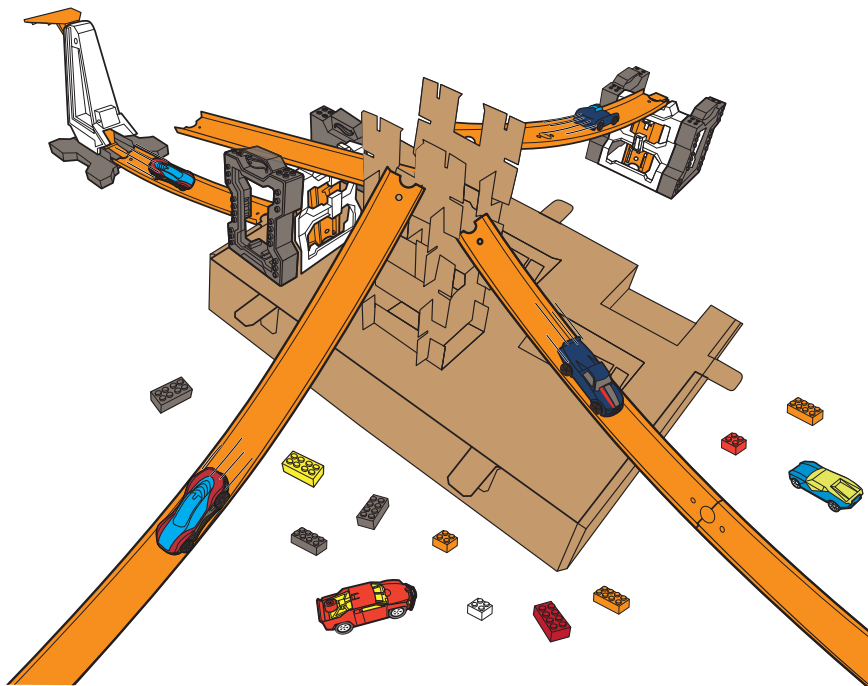

WHAT IF.....?

THE KEY TO A RAD STUNT IS IN YOUR HOME ALREADY:

CREATE A CHAIN REACTION LAUNCH!

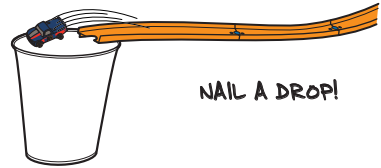
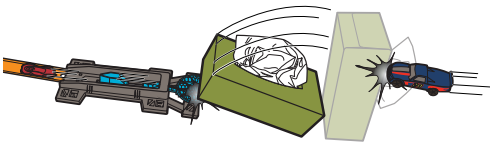

NAIL A DROP!

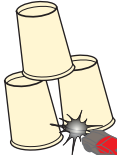

RACE THROUGH THE TUNNEL!

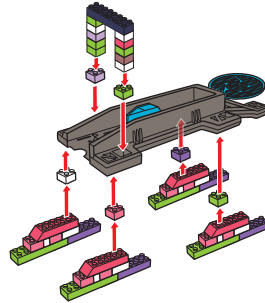

USE YOUR BRICKS FOR AWESOME TRICKS!

IMAGINE WHAT YOU COULD DO WITH THE TRACK BUILDER SYSTEM™!



FOR MORE EPIC TRACK IDEAS VISIT
WWW.HOTWHEELS.COM/TRACKBUILDER

HERE'S WHAT ELSE YOU CAN GET:

ADVERTISEMENT



DLF02
HANG IT!

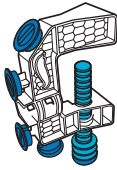

DLF03
CLAMP IT!

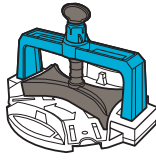

DLF04
SWITCH IT!

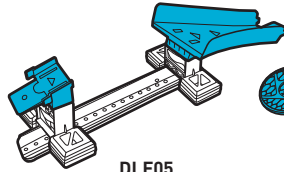

DLF05
JUMP IT!

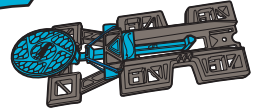

DLF06
LAUNCH IT!

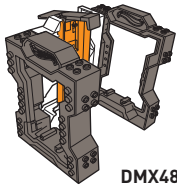

DMX48
TRICK BRICK™!

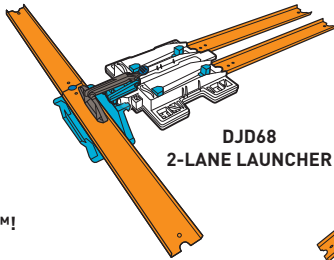

DJD68
2-LANE LAUNCHER

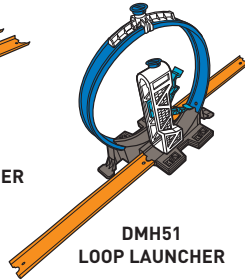

DMH51
LOOP LAUNCHER

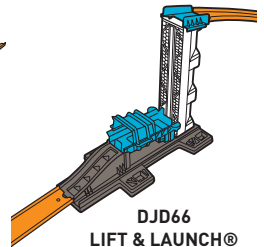

DJD66
LIFT & LAUNCH®

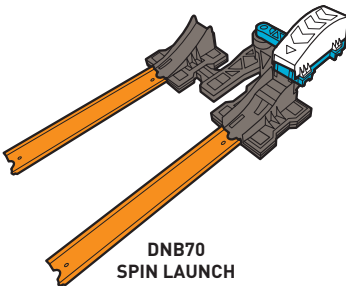

DNB70
SPIN LAUNCH

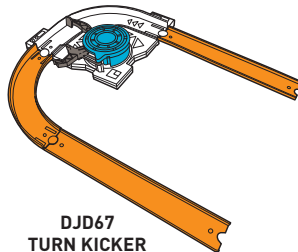

DJD67
TURN KICKER

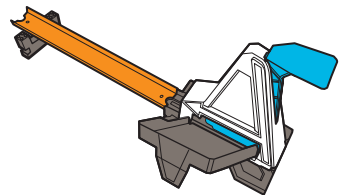

DWW94
RAPID LAUNCHER

EACH SOLD SEPARATELY, SUBJECT TO AVAILABILITY. COLORS AND DECORATIONS MAY VARY.

©2016 Mattel. All Rights Reserved. Mattel, Inc., 636 Girard Avenue, East Aurora, NY 14052, U.S.A. Consumer Services 1-800-524-8697. Mattel U.K. Ltd., Vanwall Business Park, Maidenhead SL6 4UB. Helpline 01628 500303. Mattel Australia Pty., Ltd., Richmond, Victoria. 3121. Consumer Advisory Service - 1300 135 312. Mattel East Asia Ltd., Room 503-09, North Tower, World Finance Centre, Harbour City, Tsimshatsui, HK, China. Tel.: (852) 3185-6500. Diimport & Diedarkan Oleh: Mattel Southeast Asia Pte. Ltd., No 19-1, Tower 3 Avenue 7, Bangsar South City, No 8, Jalan Kerinchi, 59200 Kuala Lumpur, Malaysia. Tel: 03-78803817, Fax: 03-78803867.