

This is a battery-operated product.
1 flyer (00001-2908G12) is required
to be placed inside the packaging.

ALSO AVAILABLE • TAMBIÉN DISPONIBLES
ÉGALEMENT DISPONIBLES • TAMBÉM DISPONÍVEL

ADVERTISEMENT • PUBLICIDAD • INFORMATION PUBLICITAIRE • PUBLICIDADE

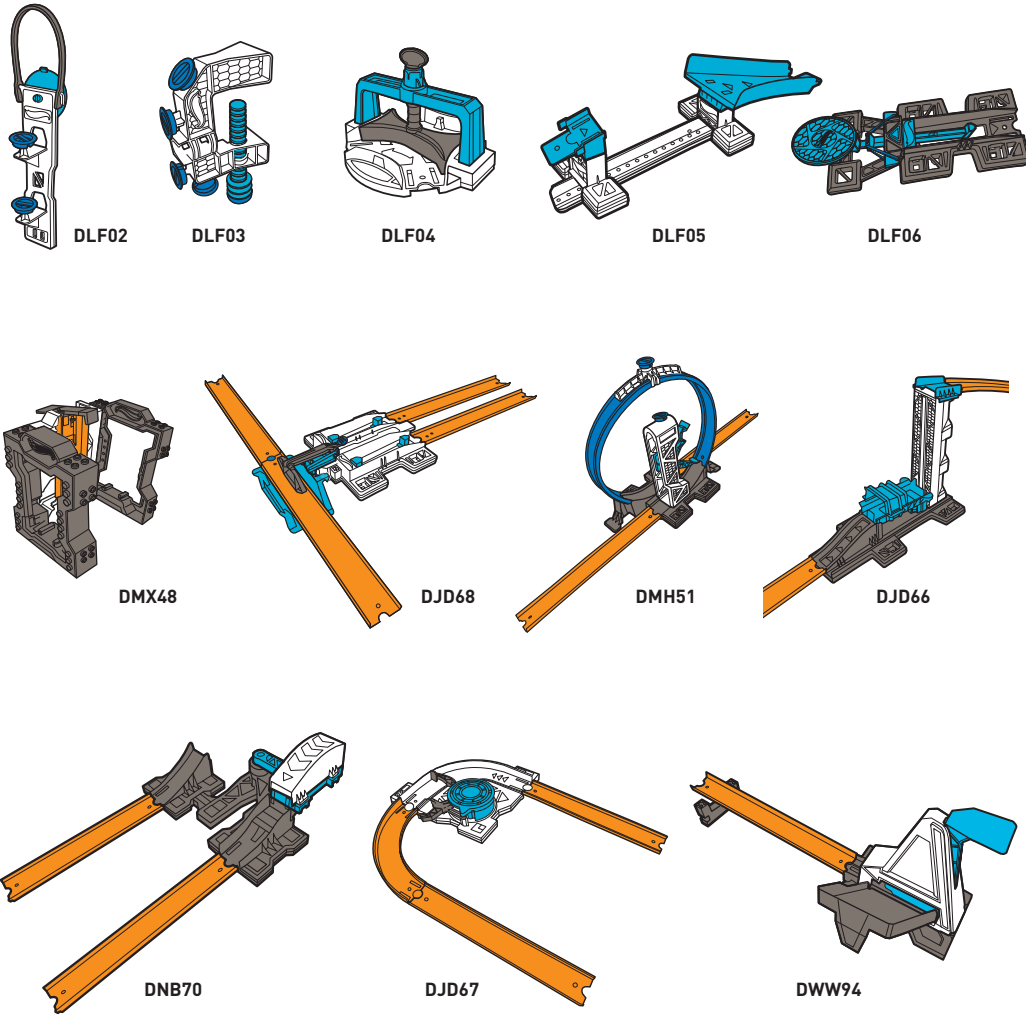

EACH SOLD SEPARATELY, SUBJECT TO AVAILABILITY. COLORS AND DECORATIONS MAY VARY.
SE VENDEN POR SEPARADO Y ESTÁN SUJETAS A DISPONIBILIDAD. LOS COLORES Y DECORACIÓN PUEDEN VARIAR DE LOS MOSTRADOS.
TOUS VENDUS SÉPARÉMENT, SELON LA DISPONIBILITÉ. LES COULEURS ET LES MOTIFS PEUVENT VARIER.
VENDIDAS SEPARADAMENTE, SUJEITAS À DISPONIBILIDADE. AS CORES E AS DECORAÇÕES PODEM VARIAR.

©2017 Mattel. All Rights Reserved. Tous droits réservés. Mattel, Inc., 636 Girard Avenue, East Aurora, NY 14052, U.S.A. Consumer Services 1-800-524-8697. Mattel Canada Inc., Mississauga, Ontario L5R 3W2. You may call us free at / Composez sans frais le 1-800-524-8697. Mattel Australia Pty., Ltd., Richmond, Victoria, 3121. Consumer Advisory Service - 1300 135 312. Mattel East Asia Ltd., Room 503-09, North Tower, World Finance Centre, Harbour City, Tsimshatsui, HK, China. Tel.: (852) 3185-6500. Diimport & Diedarkan Oleh: Mattel Southeast Asia Pte. Ltd., No 19-1, Tower 3 Avenue 7, Bangsar South City, No 8, Jalan Kerinchi, 59200 Kuala Lumpur, Malaysia. Tel: 03-78803817, Fax: 03-78803867. Mattel U.K. Ltd., Vanwall Business Park, Maidenhead SL6 4UB. Importado y distribuido por Mattel de México, S.A. de C.V., Miguel de Cervantes Saavedra No. 193, Pisos 10 y 11, Col. Granada, Delegación Miguel Hidalgo, C.P. 11520, México, D.F. R.F.C. MME-920701-NB3. Tels.: 59-05-51-00 Ext. 5206 ó 01-800-463-59-89. Mattel Chile, S.A., Avenida Américo Vespucio 501-B, Quilicura, Santiago. Tel.: 1230-020-6213. Servicio al consumidor Venezuela: Tel.: 0-800-100-9123. Mattel Argentina, S.A., Curupayti 1186, (1607) - Villa Adelina, Buenos Aires. Tel.: 0800-666-3373. Mattel Colombia, S.A., Calle 123#7-07 P.5, Bogotá. Tel.: 01800-710-2069. Mattel Perú, S.A., Av. Juan de Arona # 151, Centro Empresarial Juan de Arona, Torre C, Piso 7, Oficina 704, San Isidro, Lima 27, Perú. RUC: 20425853865. Reg. Importador: 02350-12-JUE-DIGESA. Tel.: 0800-54744. E-mail Latinoamérica: Servicio.Clientes@Mattel.com. Distribuido por: Mattel do Brasil Ltda.- CNPJ: 54.558.002/0001-20 - Rua Verbo Divino, 1488 - 2º. Andar - 04719-904 - Chácara Santo Antônio - São Paulo - SP - Brasil. Serviço de Atendimento ao Consumidor: fone 0800-550780. E-mail: sac@mattel.com. Mattel France, Parc de la Cerisaie, 1/3/5 allée des Fleurs, 94263 Fresnes Cedex. N° Cristal 0969 36 99 99 (Numéro non surtaxé) ou www.lesjouetsmattel.fr. Mattel España, S.A., Aribau 200, 08036 Barcelona. cservice.spain@mattel.com Tel: 902203010 http://www.service.mattel.com/es. Mattel Portugal Lda, Av. da República, nº 90/96, 2º andar Fracção 2, 1600-206 Lisboa. Tel. Número Verde: 800 10 10 71 -consumidor@mattel.com.

HOT WHEELS TRACK BUILDER SYSTEM

BUILDER'S GUIDE
GUÍA DEL CREADOR DE PISTAS
GUIDE DE CONSTRUCTION
GUIA DE MONTAGEM



WARNING:
CHOKING HAZARD - Small parts.
Not for children under 3 years.

ADVERTENCIA:
PELIGRO DE ASFIXIA. Juguete no recomendado para menores de 3 años. Contiene piezas pequeñas que podrían provocar asfixia en caso de ser ingeridas por el niño/a.

ATTENTION:
DANGER D'ÉTOUFFEMENT -
Petits éléments. Ne convient pas aux enfants de moins de 36 mois.

ADVERTENCIA: peligro de atragantamiento. Juguete no recomendado para menores de 3 años, porque contiene piezas pequeñas que podrían provocar asfixia en caso de ser ingeridas o inhaladas por el/la niño/a. • ATENÇÃO: Não é indicado para crianças menores de 36 meses, por conter partes pequenas que podem ser engolidas ou inaladas e provocar asfixia.

5+



DWW97-4B70
1101330357-4LB
service.mattel.com

HOTWHEELS.COM



Featuring

MEGA
CONSTRUX



HANG ON TO THIS GUIDE, IT HAS KEY INFORMATION TO BUILD RAD STUNTS! • GUARDA ESTA GUÍA. INCLUYE INFORMACIÓN IMPORTANTE PARA CREAR INCREÍBLES ACROBACIAS. • CONSERVE CE GUIDE, CAR IL CONTIENT DES RENSEIGNEMENTS UTILES POUR CONSTRUIRE DE SUPER CASCADES! • SIGA ESTE GUIA, POIS CONTÉM INFORMAÇÕES IMPORTANTES PARA MONTAR AS MANOBRAS!

MAKE IT EPIC™! • ¡PONLE TU TOQUE PERSONAL!
C'EST PARTI! • PISE FUNDO!

BRIDGE BASE • BASE DEL PUENTE
BASE DU PONT • BASE DA PONTE

PAGE 4
PÁGINA 4

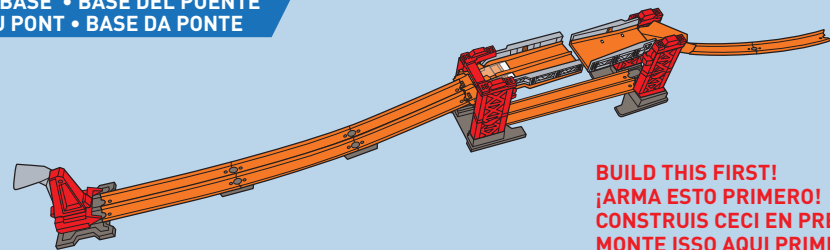

BUILD THIS FIRST!
¡ARMA ESTO PRIMERO!
CONSTRUIS CECI EN PREMIER!
MONTE ISSO AQUI PRIMEIRO!

1

PAGE 8
PÁGINA 8

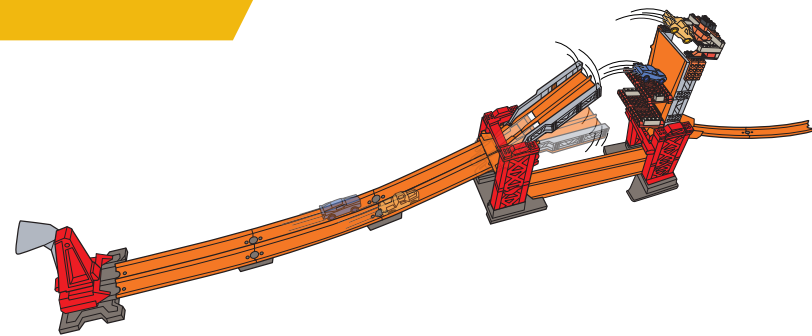

2

PAGE 16
PÁGINA 16

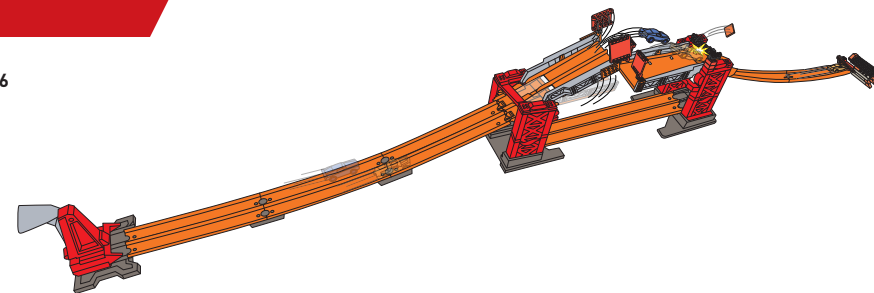

3

PAGE 26
PÁGINA 26

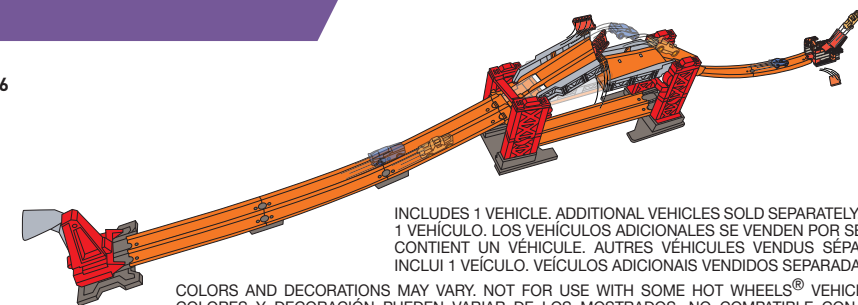

INCLUDES 1 VEHICLE. ADDITIONAL VEHICLES SOLD SEPARATELY. • INCLUYE 1 VEHÍCULO. LOS VEHÍCULOS ADICIONALES SE VENDEN POR SEPARADO. • CONTIENT UN VÉHICULE. AUTRES VÉHICULES VENDUS SÉPARÉMENT. • INCLUI 1 VEÍCULO. VEÍCULOS ADICIONAIS VENDIDOS SEPARADAMENTE.

COLORS AND DECORATIONS MAY VARY. NOT FOR USE WITH SOME HOT WHEELS® VEHICLES. • LOS COLORES Y DECORACIÓN PUEDEN VARIAR DE LOS MOSTRADOS. NO COMPATIBLE CON ALGUNOS VEHÍCULOS HOT WHEELS. • LES COULEURS ET LES MOTIFS PEUVENT VARIER. NON COMPATIBLE AVEC CERTAINS VÉHICULES HOT WHEELS. • AS CORES E AS DECORAÇÕES PODEM VARIAR. NÃO É COMPATÍVEL COM ALGUNS VEÍCULOS HOT WHEELS.

2

CONTENTS • CONTENIDO • CONTENU • CONTEÚDO

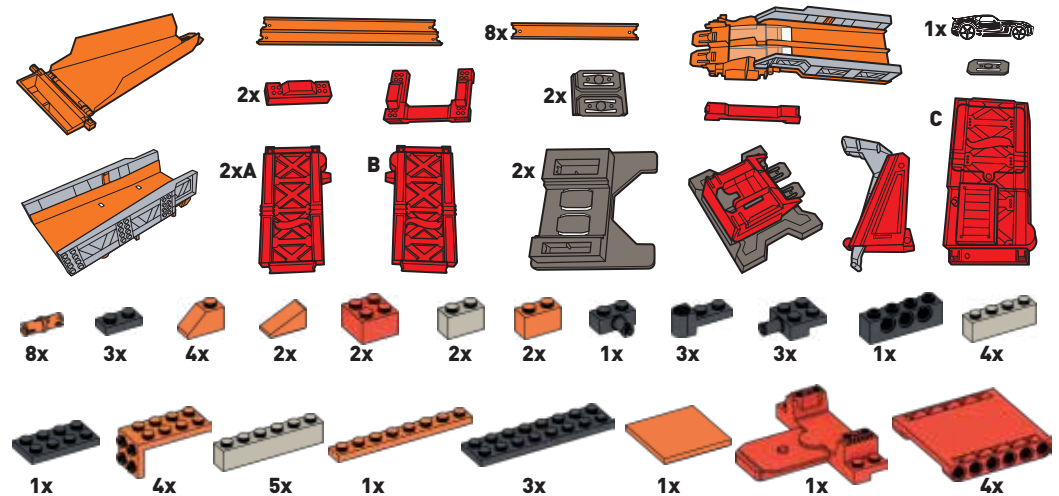

BATTERY INSTALLATION • COLOCACIÓN DE LAS PILAS
INSTALLATION DES PILES • INSTALAÇÃO DAS PILHAS

- Requires 2 "D" size (LR20) alkaline batteries (not included).
- Unscrew the battery cover with a Phillips head screwdriver (not included).
- Install 2 new "D" size (LR20) alkaline batteries (not included) in the orientation (+/-) shown.
- Replace battery cover and tighten screws.
- For longer life use alkaline batteries.
- Replace batteries when the motor can no longer move the bridge.
- Dispose of battery(ies) safely.
- When exposed to an electrostatic source, the product may malfunction. To resume normal operation, remove and re-install the batteries.

- Funciona con 2 pilas alcalinas D (LR20) x 1,5V (no incluidas).
- Desatornilla la tapa del compartimento de pilas con un desatornillador de cruz (no incluido).
- Instala 2 pilas nuevas alcalinas D (LR20) x 1,5V (no incluidas) tal como se muestra (+/-).
- Cierra la tapa del compartimento y aprieta los tornillos.
- Para una mayor duración, usa sólo pilas alcalinas.
- Sustituye las pilas cuando el motor deje de mover el puente.
- Desecha las pilas gastadas apropiadamente.
- Quizá el producto no funcione correctamente si se expone a una fuente electrostática. Para reanudar el funcionamiento normal, saca y vuelve a introducir las pilas.

- Fonctionne avec 2 piles alcalines D (LR20), non incluses.
- Dévisser le couvercle du compartiment des piles avec un tournevis cruciforme (non inclus).
- Insérer 2 piles alcalines D (LR20) neuves (non incluses) dans le sens indiqué (+/-).
- Remettre le couvercle et serrer les vis.
- Utiliser des piles alcalines pour une durée plus longue.
- Remplacer les piles lorsque le moteur ne parvient plus à faire bouger le pont.
- Jeter les piles usées dans un conteneur réservé à cet usage.
- Le produit peut ne pas fonctionner correctement s'il est exposé à une source d'électricité statique. Pour rétablir le fonctionnement normal du produit, retirer les piles et les remettre en place.

- Funciona com 2 pilhas alcalinas D (LR20), não incluidas.
- Solte o parafuso da tampa do compartimento de pilhas com uma chave Phillips (não incluída).
- Coloque 2 pilhas alcalinas D (LR20), não incluidas, seguindo orientação de polaridade (+/-).
- Recoloque a tampa do compartimento de pilhas e aperte o parafuso.
- Para maior durabilidade use pilhas alcalinas.
- Troque as pilhas quando o motor não conseguir mais mover a ponte.
- Descarte as pilhas gastas em local apropriado.
- Não coloque o produto perto de nenhuma fonte eletrostática, para evitar problemas de funcionamento. Para voltar à operação normal, remova e reinstale as pilhas.

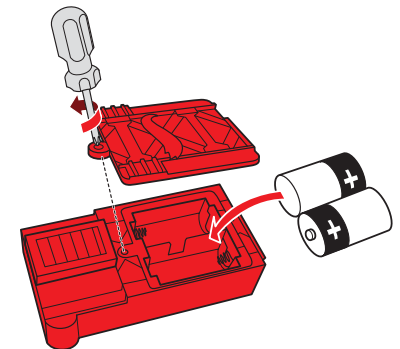

CHECK OUT THE HOT WHEELS® YOUTUBE CHANNEL FOR EPIC IDEAS! WWW.YOUTUBE.COM/HOTWHEELS
¡VISITA EL CANAL DE HOT WHEELS EN YOUTUBE PARA VER IDEAS INCREIBLES! WWW.YOUTUBE.COM/HOTWHEELS
POUR DES IDÉES INCROYABLES, VISITEZ LA CHAÎNE HOT WHEELS SUR YOUTUBE! WWW.YOUTUBE.COM/HOTWHEELS
CONFIRA O CANAL HOT WHEELS NO YOUTUBE PARA MAIS IDEIAS! WWW.YOUTUBE.COM/HOTWHEELS

YouTube

3

CREATE BRIDGE BASE • CREA LA BASE DEL PUENTE
 CONSTRUCTION DE LA BASE DU PONT • CRIE A BASE DA PONTE

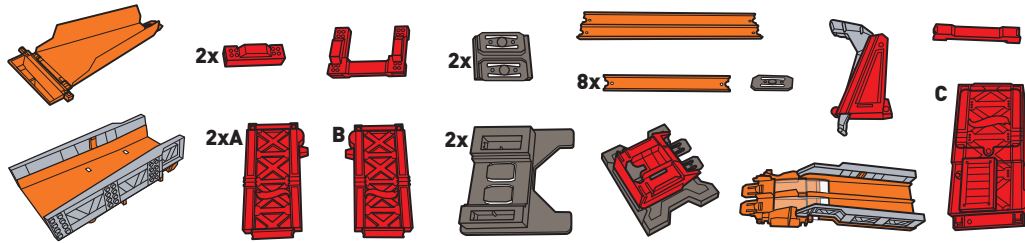

* INSTALL BATTERIES FIRST (PAGE 3).
 PRIMERO INSTALA LAS PILAS (PÁGINA 3).
 INSTALLE D'ABORD LES PILES (PAGE 3).
 COLOQUE AS PILHAS PRIMEIRO (PÁGINA 3).

1.

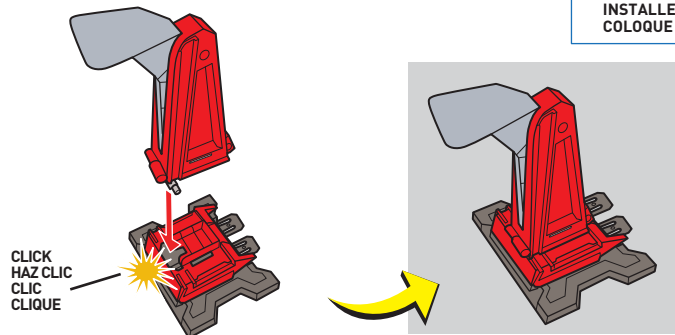

2.

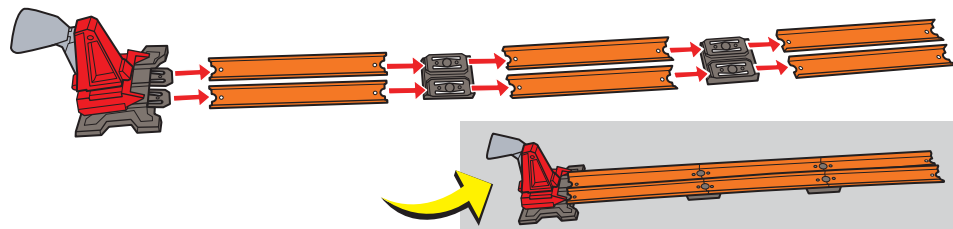

3.

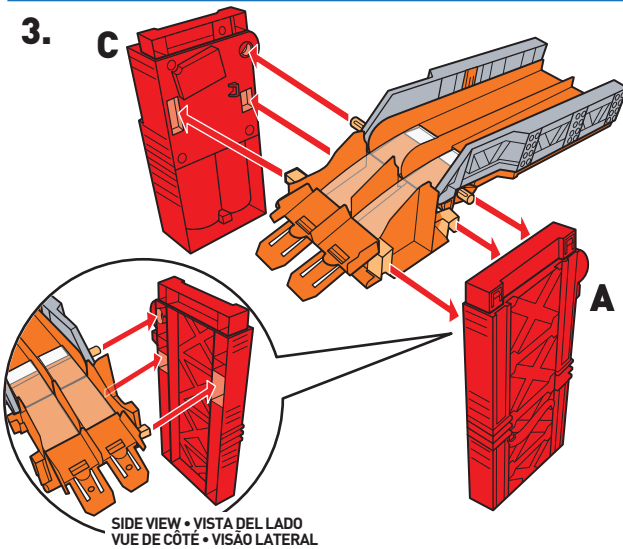

4.

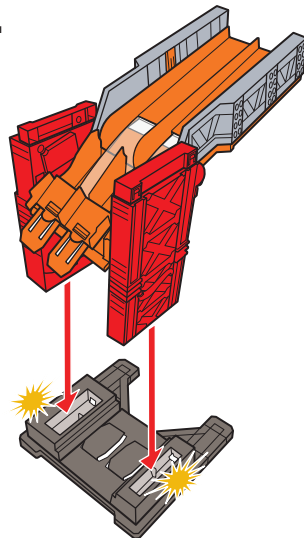

5.

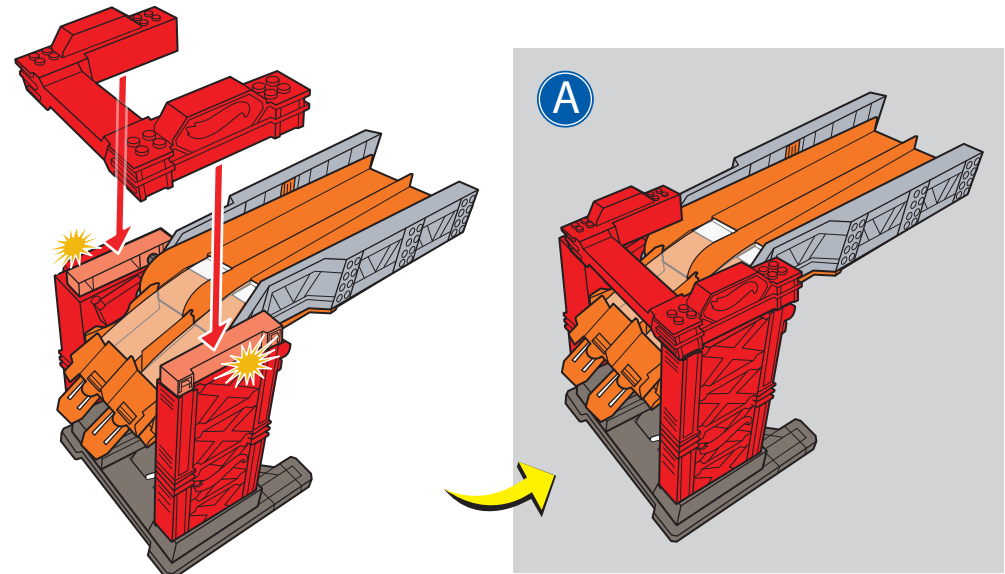

6.

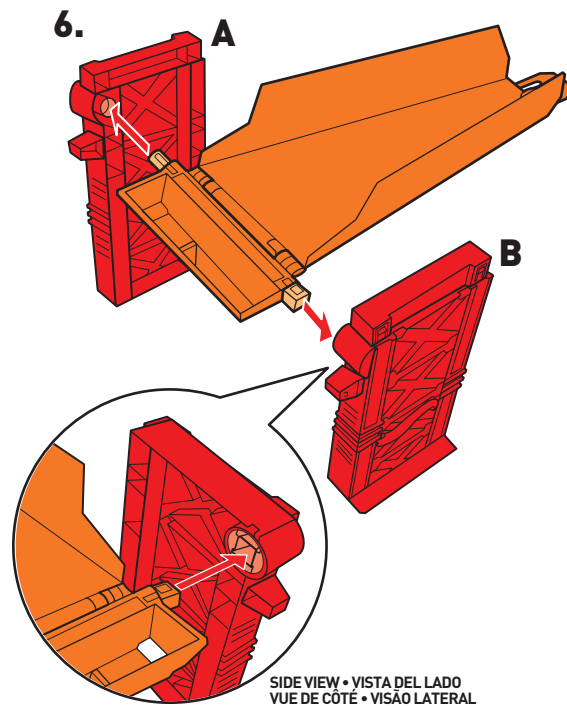

7.

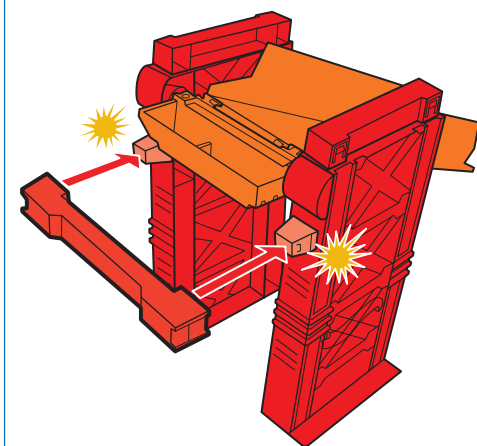

8.

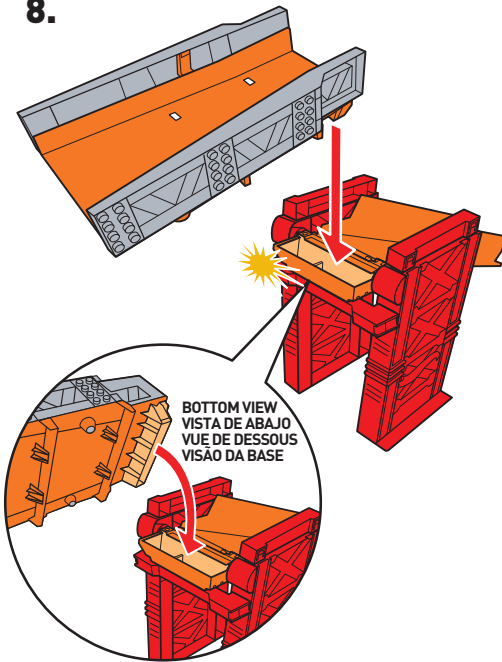

9.

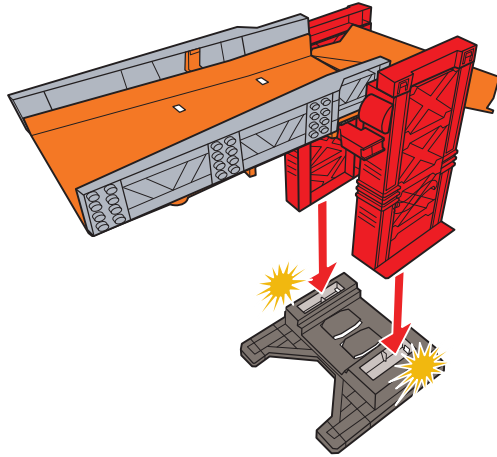

10.

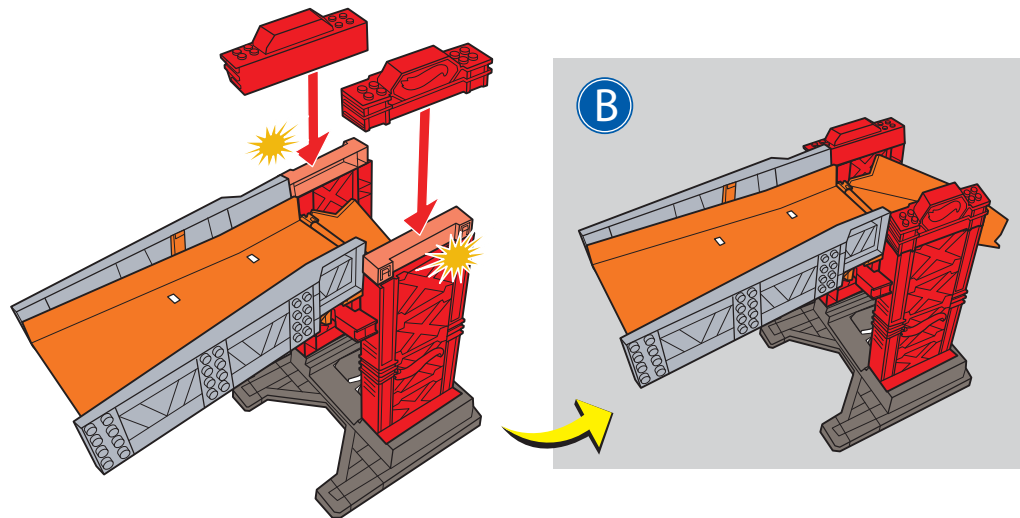

11.

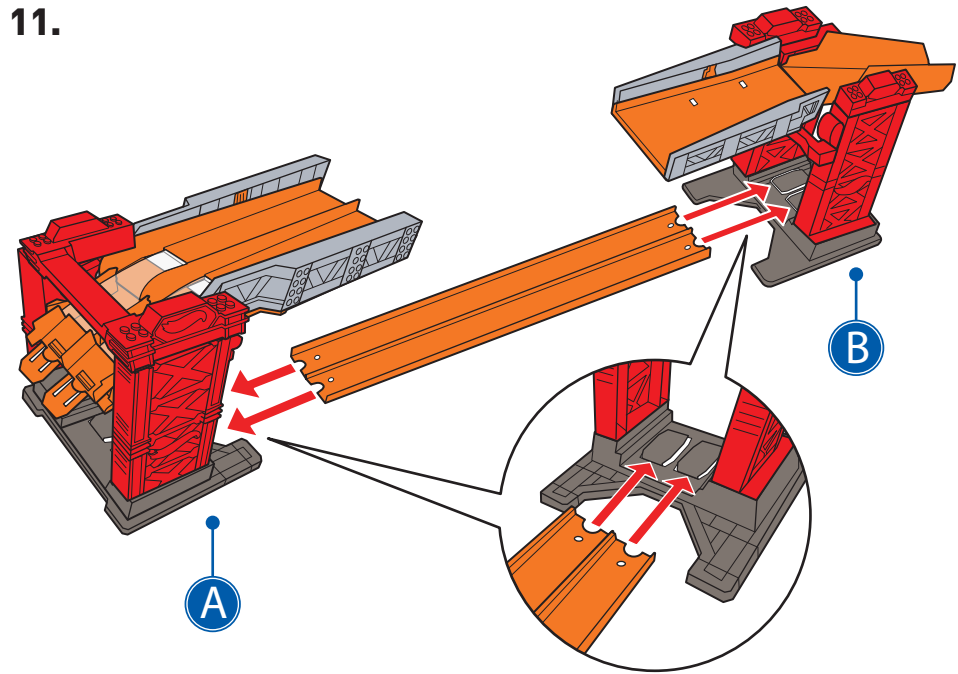

12.

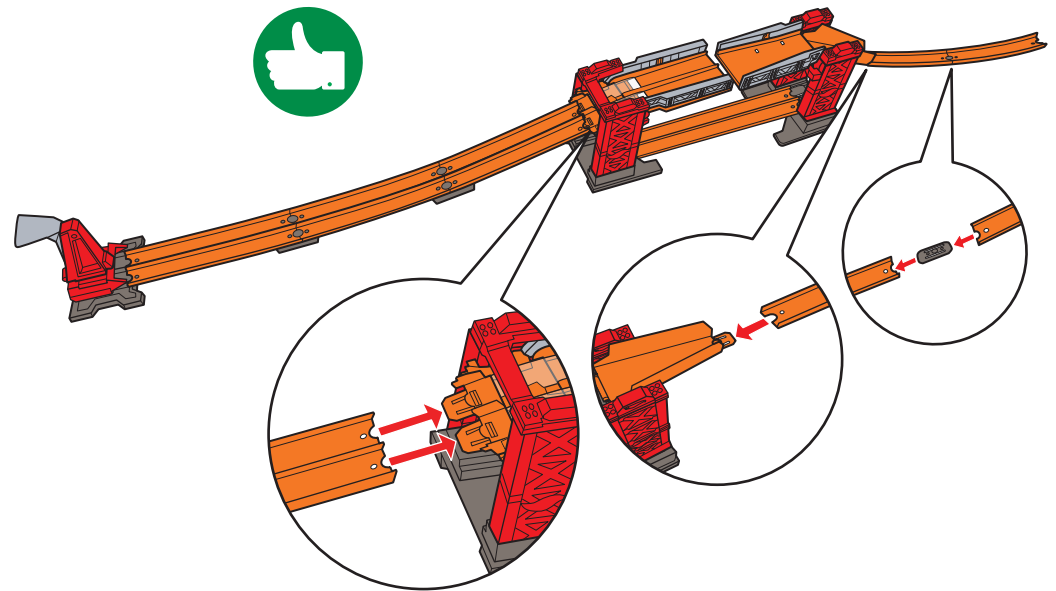

1

BUILD THESE: • ARMA ESTO:
CONSTRUIS CECI : • MONTE ISSO:

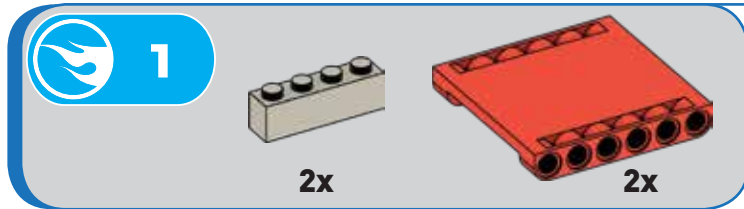
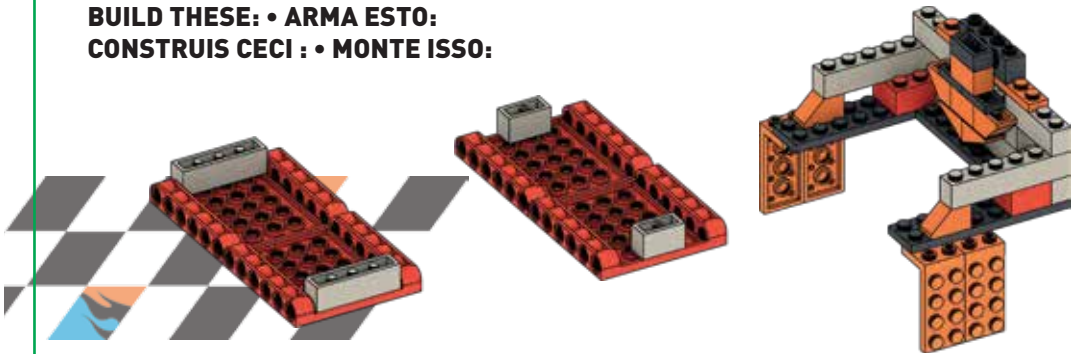

1.

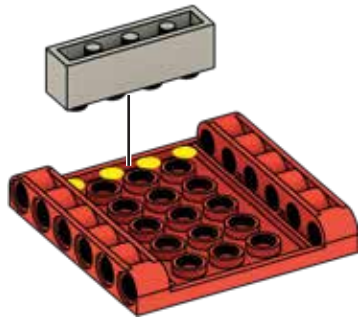

2.

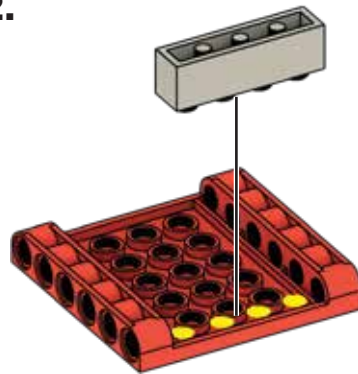

3.

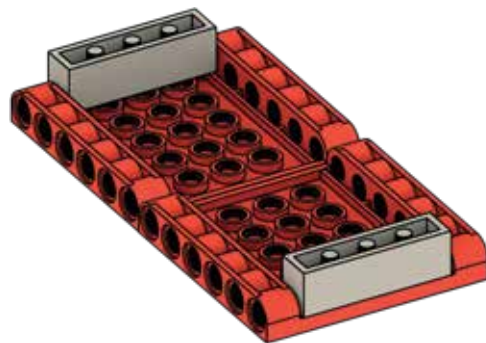

2

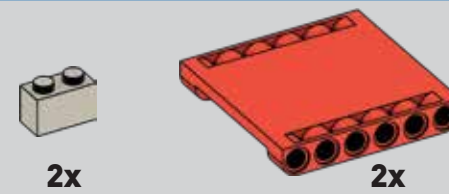

1.

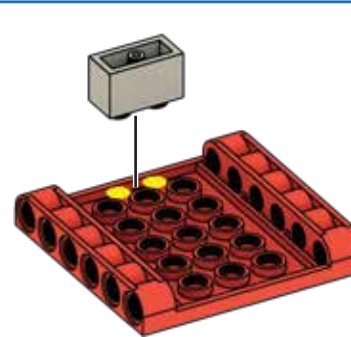

2.

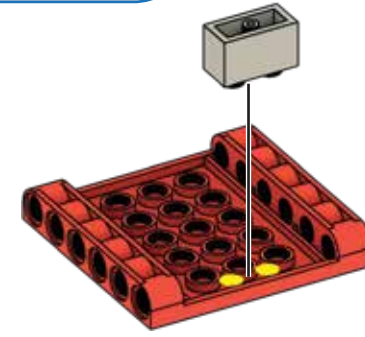

3.

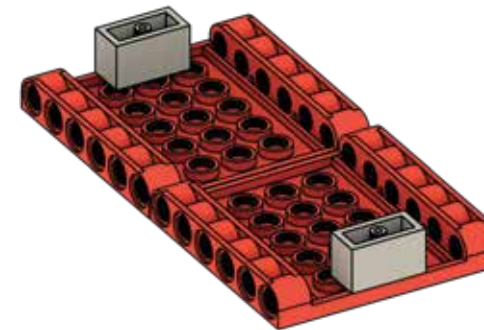

3

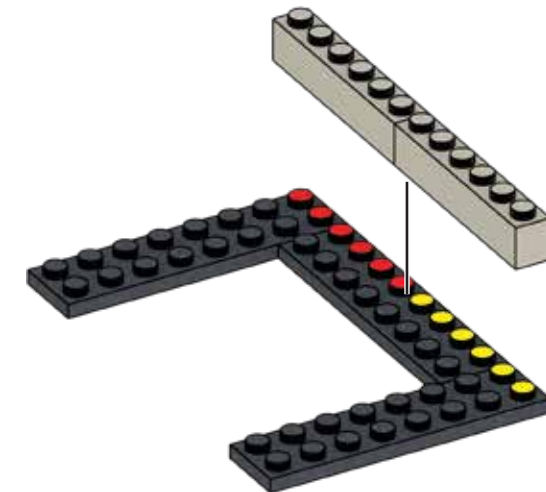
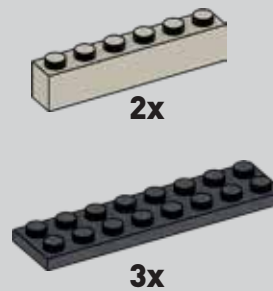

4



2x

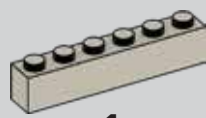

1x

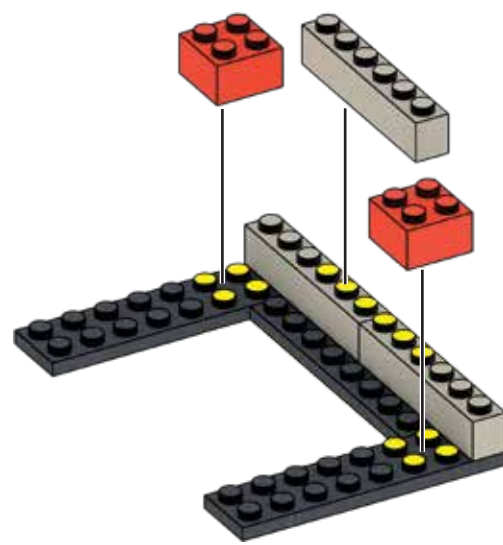

6



2x

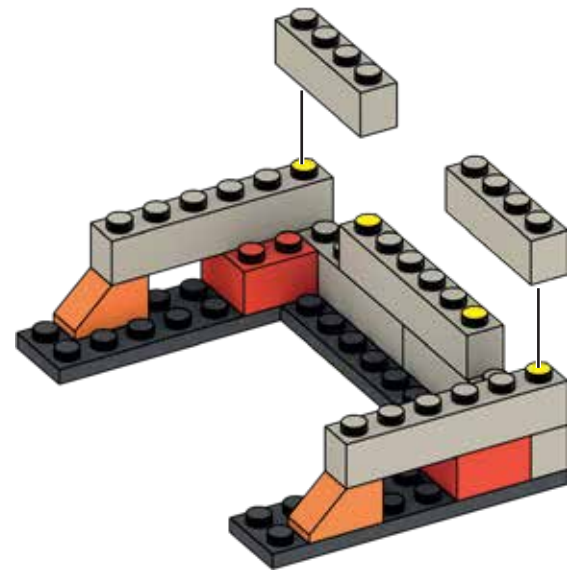

5



2x

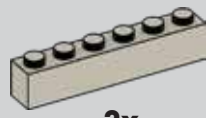

2x

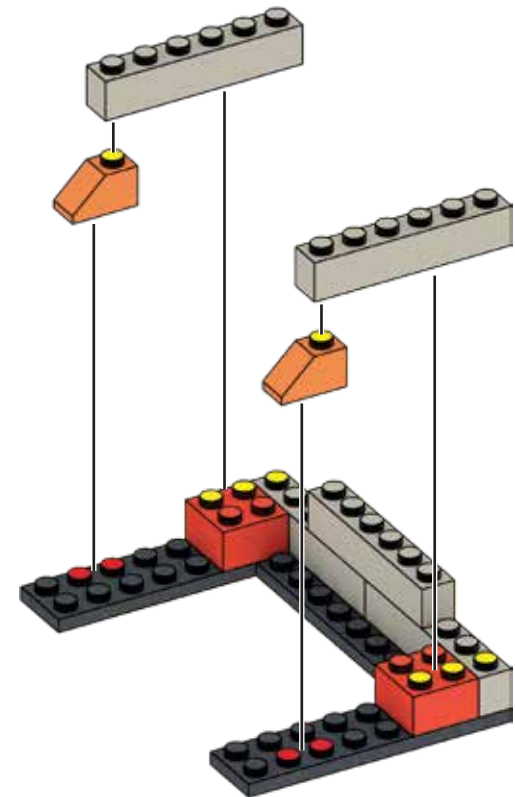

7



1x

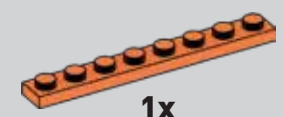

1x

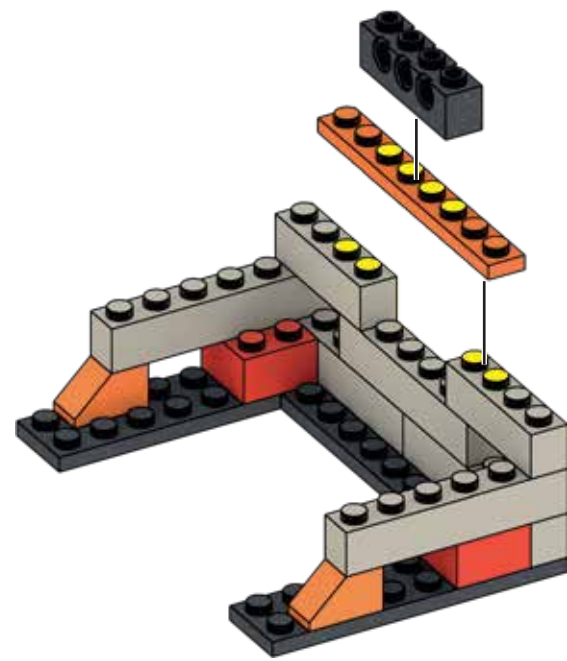



1.

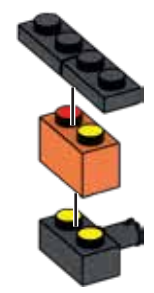

2.

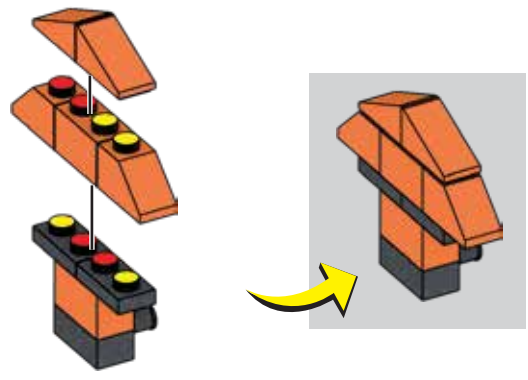

3.

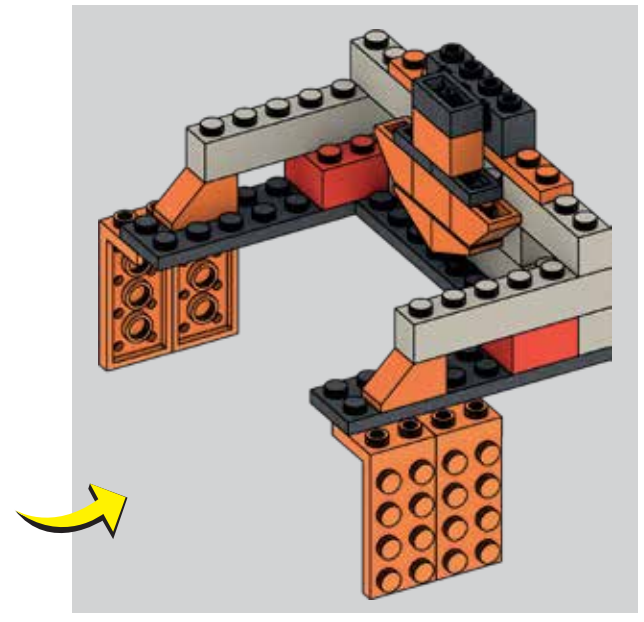
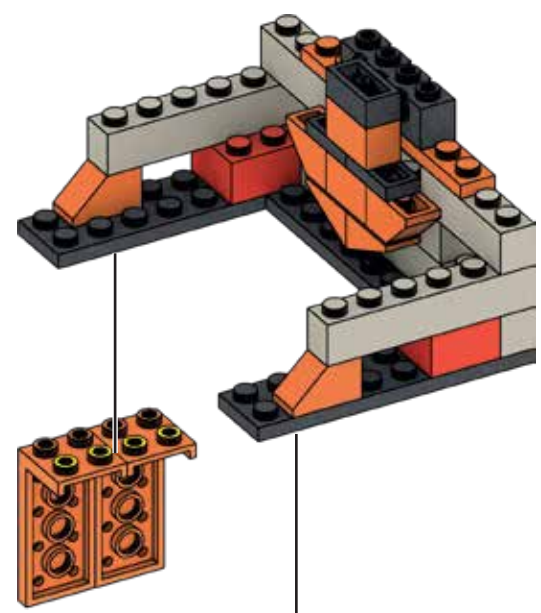
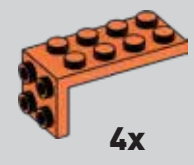
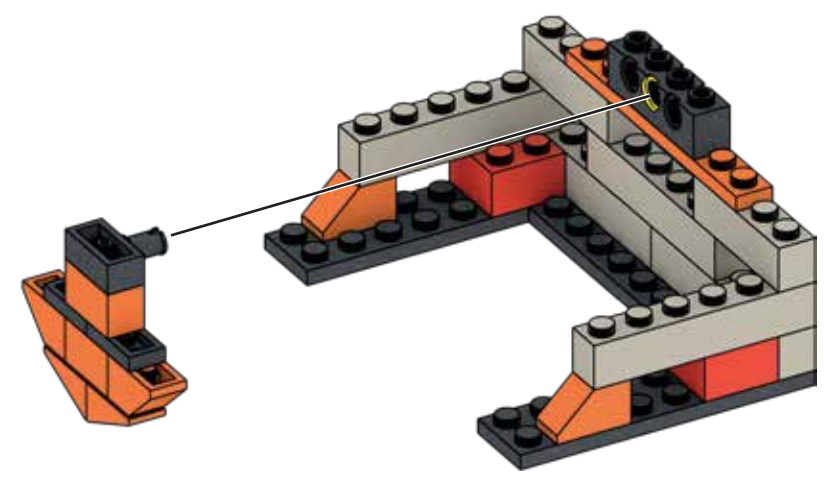



1.

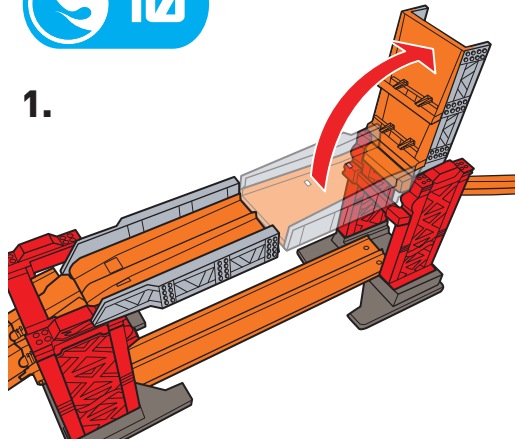

2.

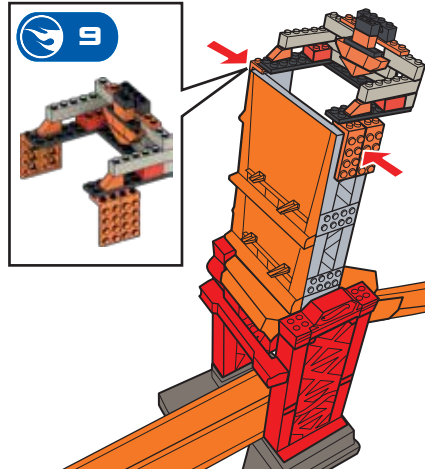

3.

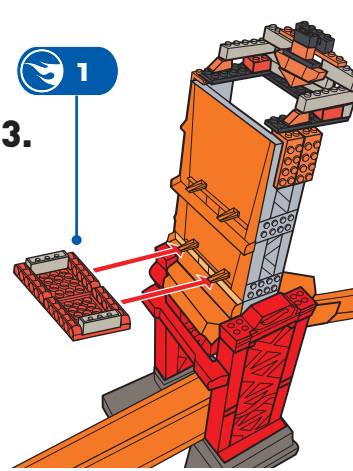

4.

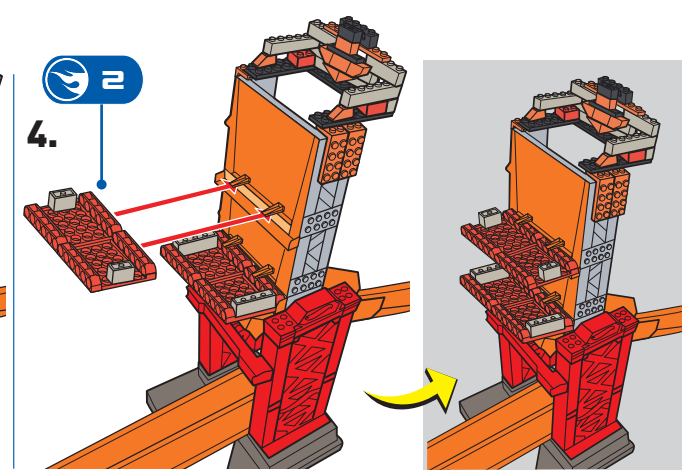

LAUNCH YOUR CAR! ¡LANZA EL AUTO! LANCE TA VOITURE! LANCE O CARRO!



EXPERIMENT WITH DIFFERENT ANGLES OF THE JUMP!
¡INTENTA CON DIFERENTES ÁNGULOS DE SALTO!
ESSAIE DIFFÉRENTS ANGLES DE SAUT!
TESTE COM DIFERENTES ÂNGULOS DE SALTO!

POWER ON. • ENCIÉNDELO.
METTRE EN MARCHÉ. • LIGAR.

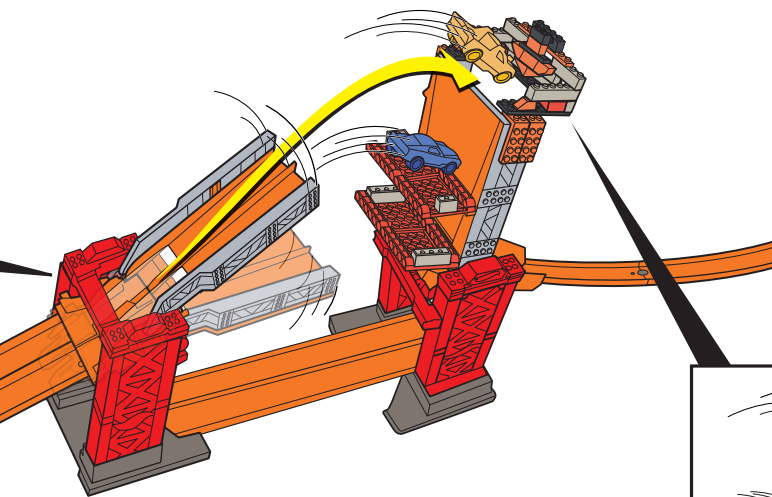
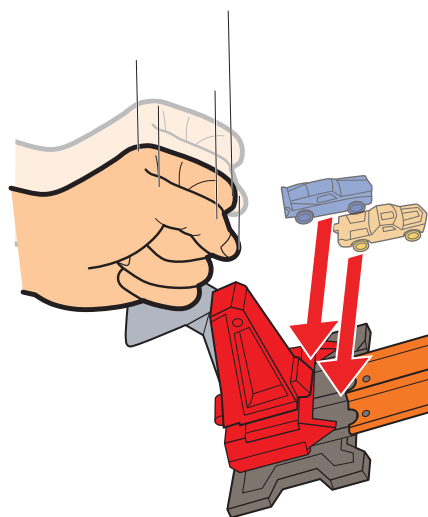

ADDITIONAL CHALLENGE: LEAVE THE MOTOR ON TO SEE IF YOU CAN MAKE IT. • RETO EXTRA: DEJA EL MOTOR ENCENDIDO Y VE SI LO PUEDES LOGRAR. • DÉFI SUPPLÉMENTAIRE : LAISSE LE MOTEUR EN MARCHÉ POUR VOIR SI TU PEUX Y ARRIVER. • DESAFIO EXTRA: DEIXE O MOTOR LIGADO PARA VER SE VOCÊ CONSEGUE.

NOTE: FOR BEST PERFORMANCE, PLAY ON LOW PILE CARPET OR HARD SURFACES. • ATENCIÓN: PARA OBTENER MEJORES RESULTADOS, JUEGA SOBRE ALFOMBRA BAJA O SUPERFICIES DURAS. • REMARQUE : POUR UN MEILLEUR FONCTIONNEMENT, JOUE SUR UN TAPIS À POILS RAS OU SUR DES SURFACES DURES. • NOTA: PARA MELHOR DESEMPENHO, BRINQUE SOB UM CARPETE/TAPETE DE TRAMAS CURTAS OU SUPERFÍCIES LISAS, DURAS E PLANAS.

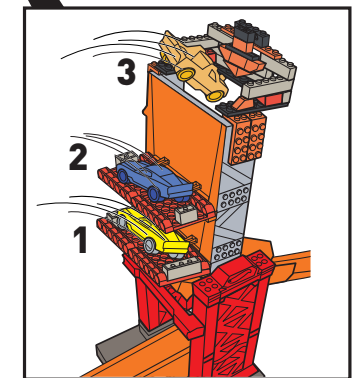

2

BUILD THESE: • ARMA ESTO:
CONSTRUIS CECI : • MONTE ISSO:

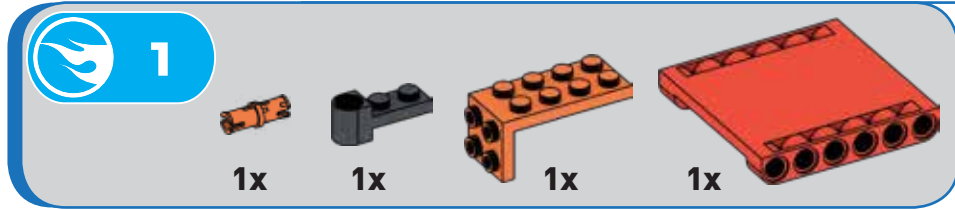
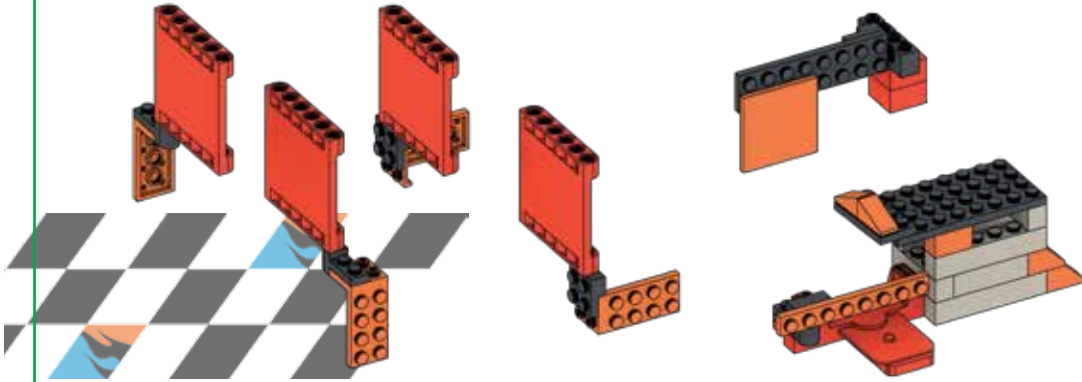

1.

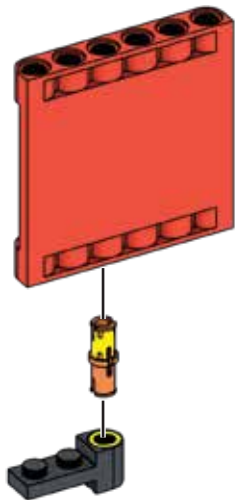

2.

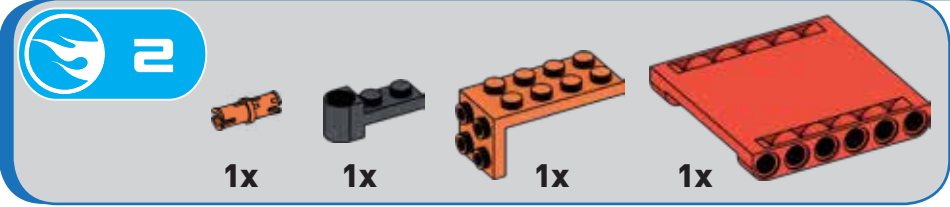
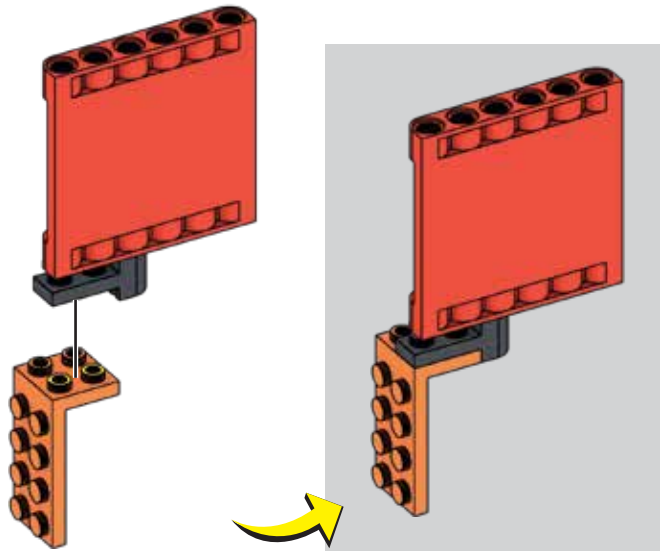

1.

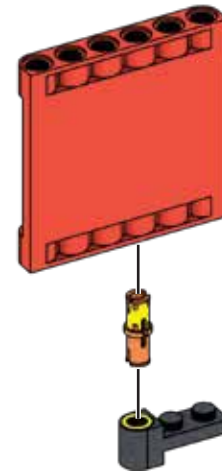

2.

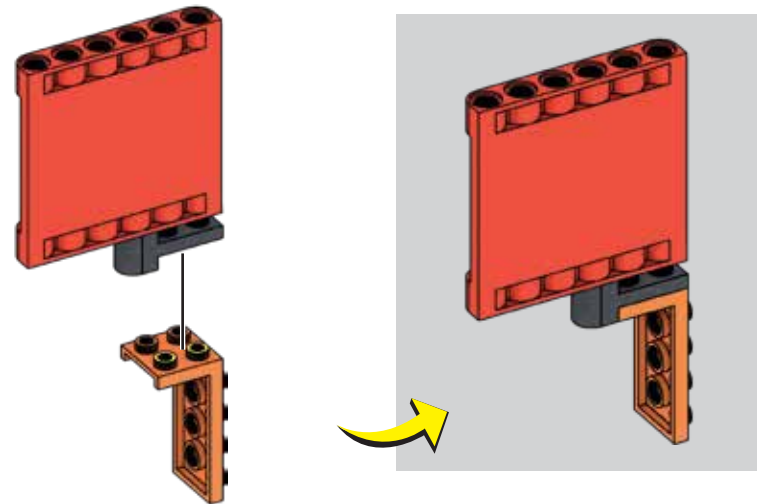

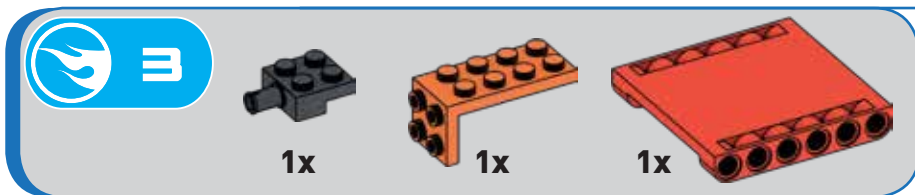

1.

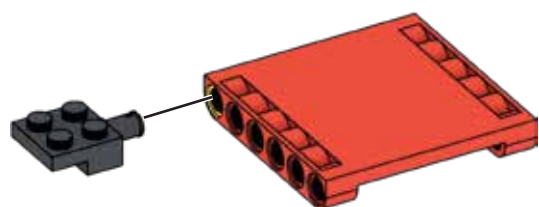

2.

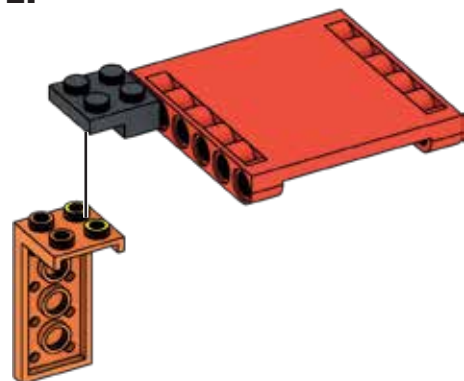

3.

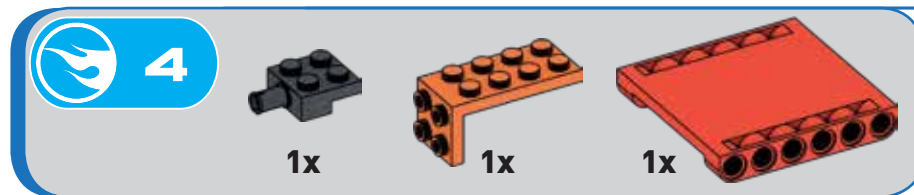
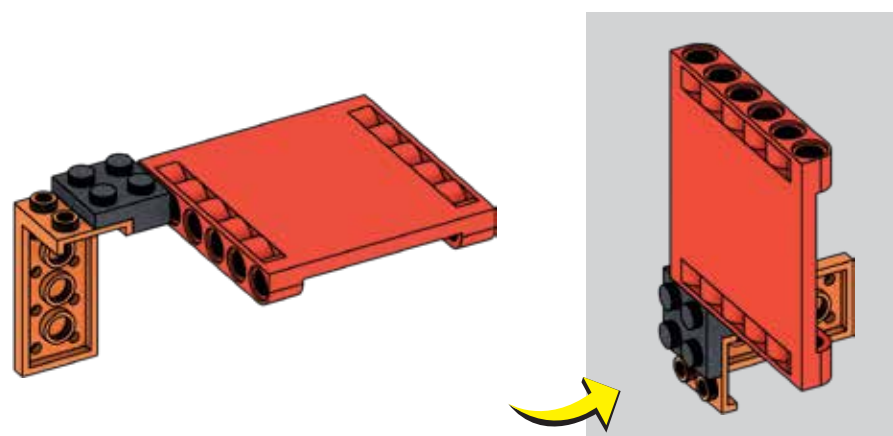

1.

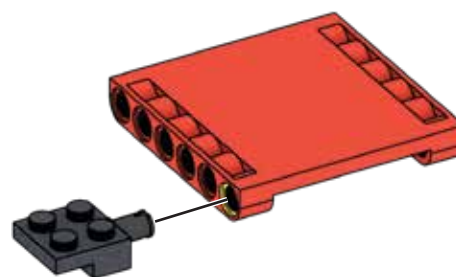

2.

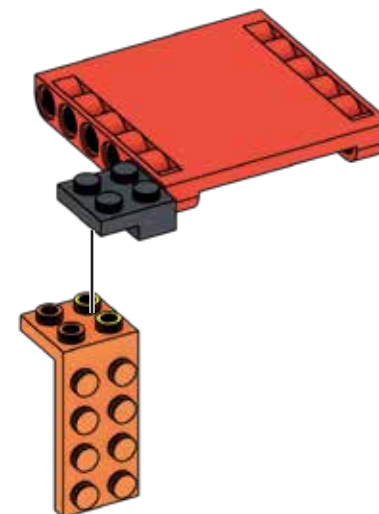

3.

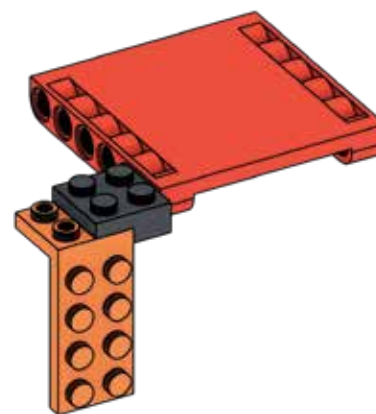

5

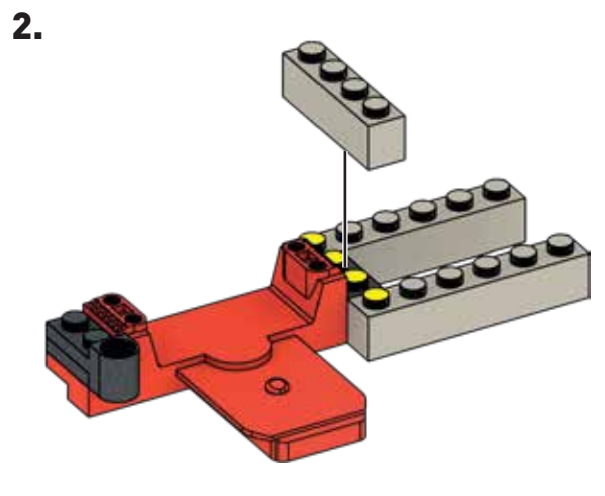
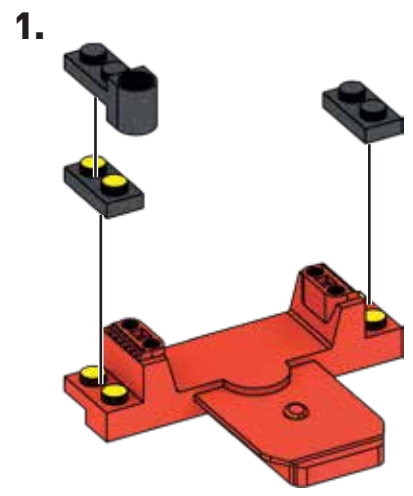
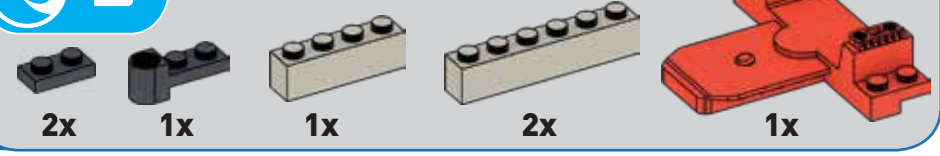

6

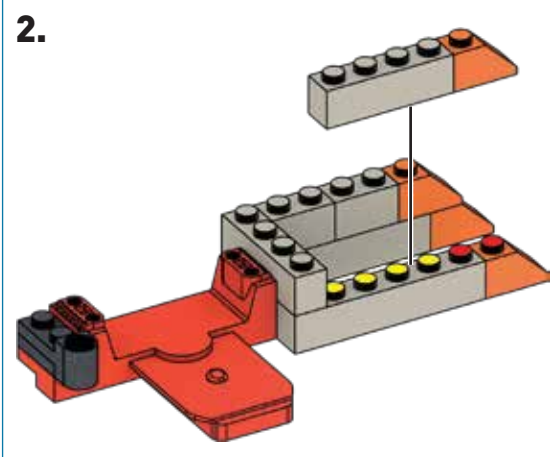
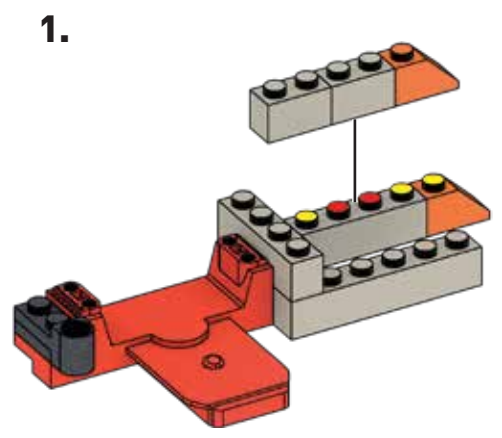
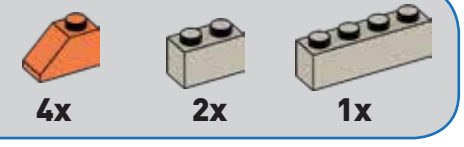

7

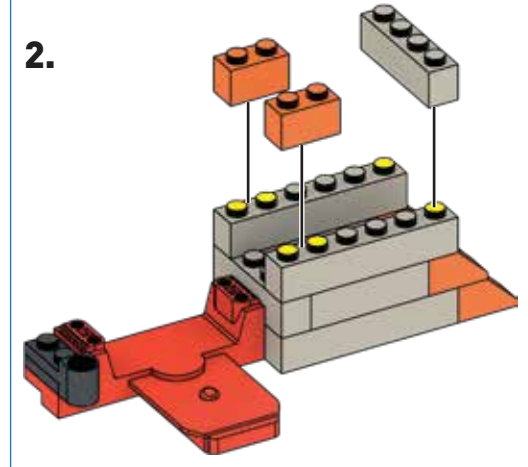
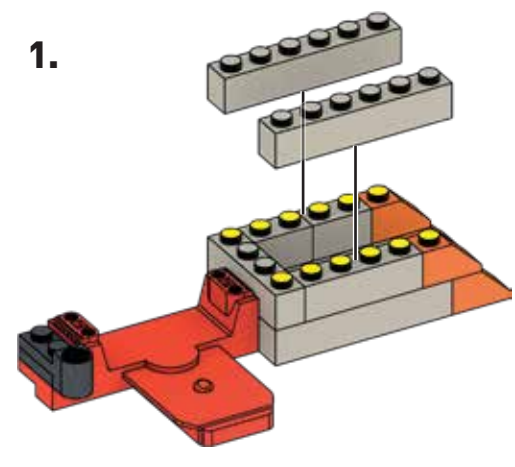

8

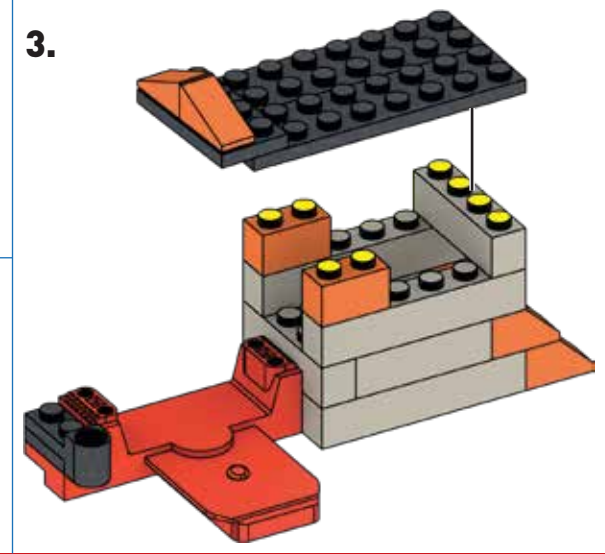

9

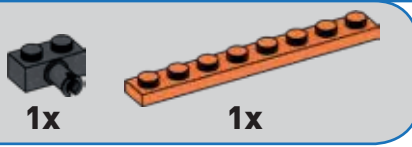

1.

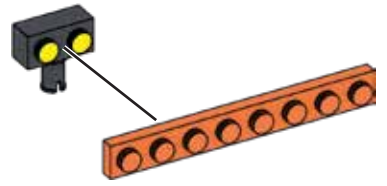

2.

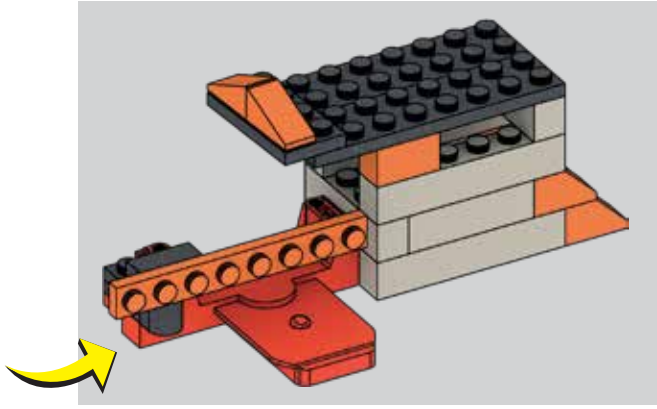
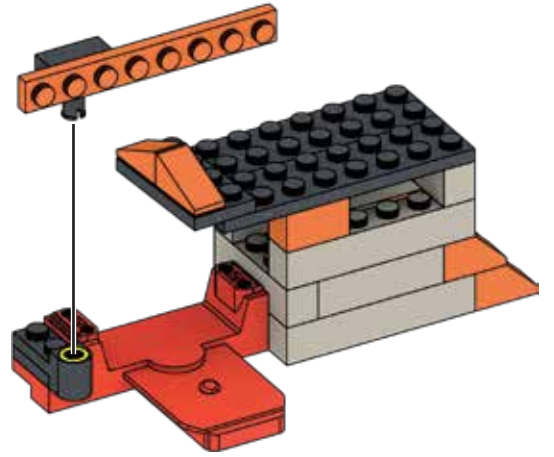

10

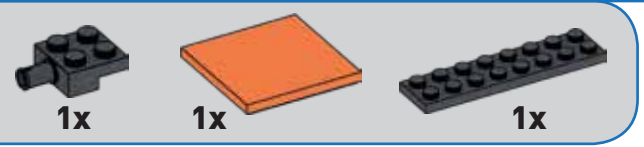

1.

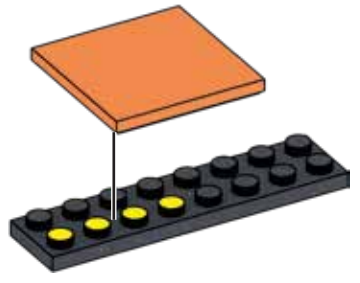

2.

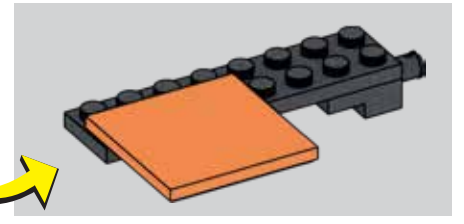
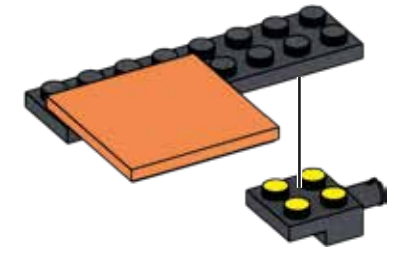

11



1.

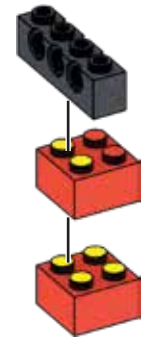

2.

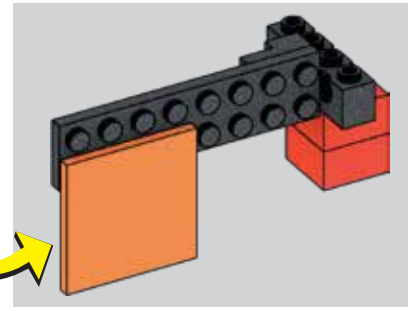

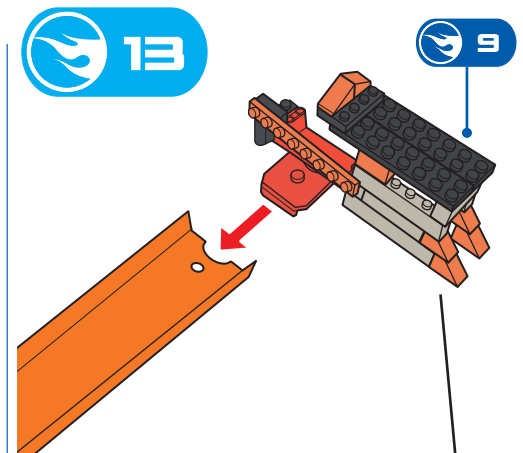
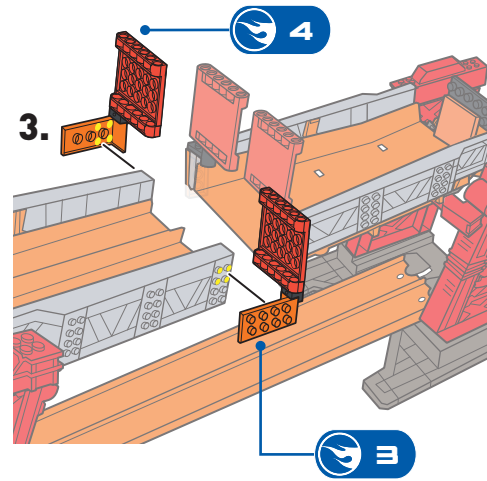
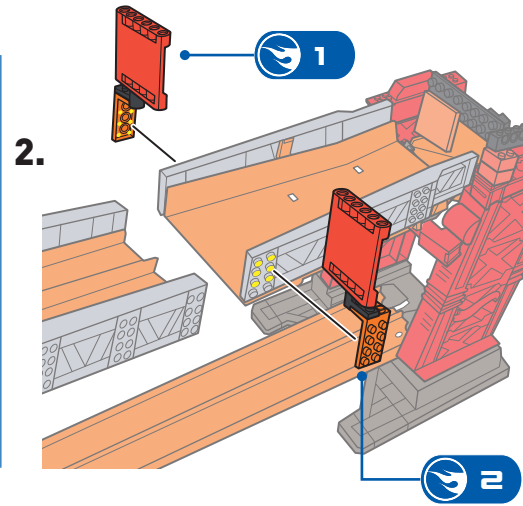
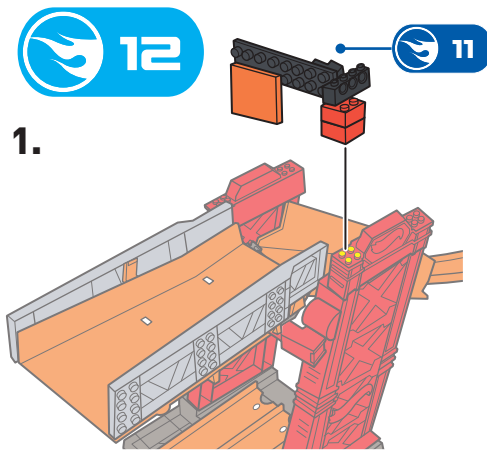

LAUNCH YOUR CAR! ILANZA EL AUTO! LANCE TA VOITURE! LANCE O CARRO!

POWER ON. • ENCIÉNDELO.
METTRE EN MARCHÉ. • LIGAR.

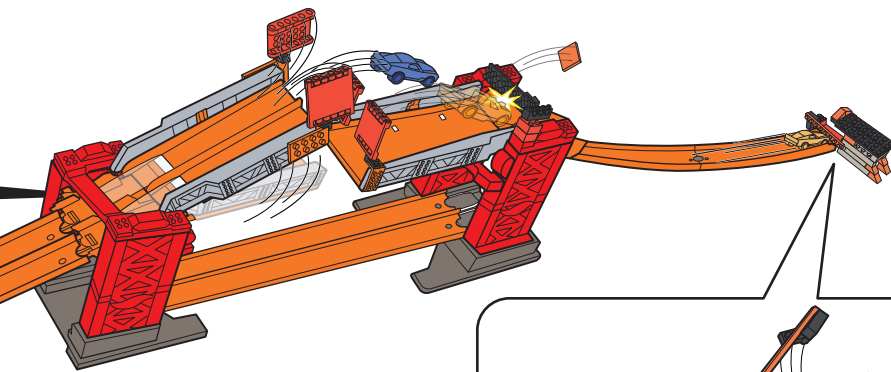
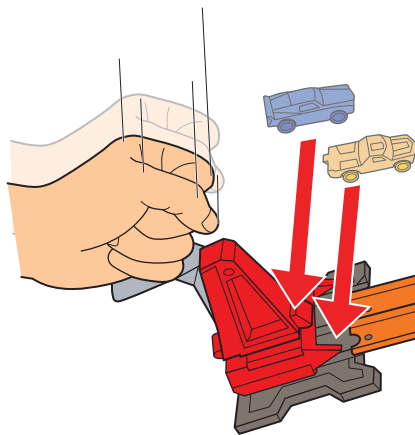

MAKE A BREAKTHROUGH?
¿NUEVO LOGRO?
VAS-TU RÉUSSIR À PASSER?
CONSEGUE PASSAR POR UMA BARREIRA?

NOTE: FOR BEST PERFORMANCE, PLAY ON LOW PILE CARPET OR HARD SURFACES. • ATENCIÓN: PARA OBTENER MEJORES RESULTADOS, JUEGA SOBRE ALFOMBRA BAJA O SUPERFICIES DURAS. • REMARQUE : POUR UN MEILLEUR FONCTIONNEMENT, JOUE SUR UN TAPIS À POILS RAS OU SUR DES SURFACES DURES. • NOTA: PARA MELHOR DESEMPENHO, BRINQUE SOB UM CARPETE/TAPETE DE TRAMAS CURTAS OU SUPERFICIES LISAS, DURAS E PLANAS.

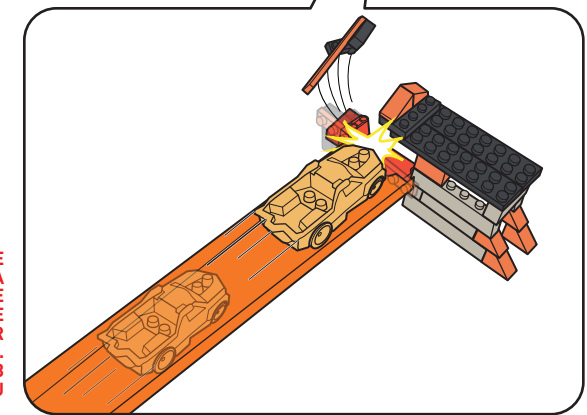

3

BUILD THESE: • ARMA ESTO:
CONSTRUIS CECI : • MONTE ISSO:

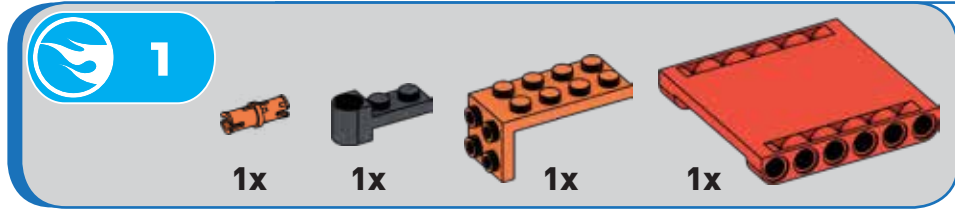
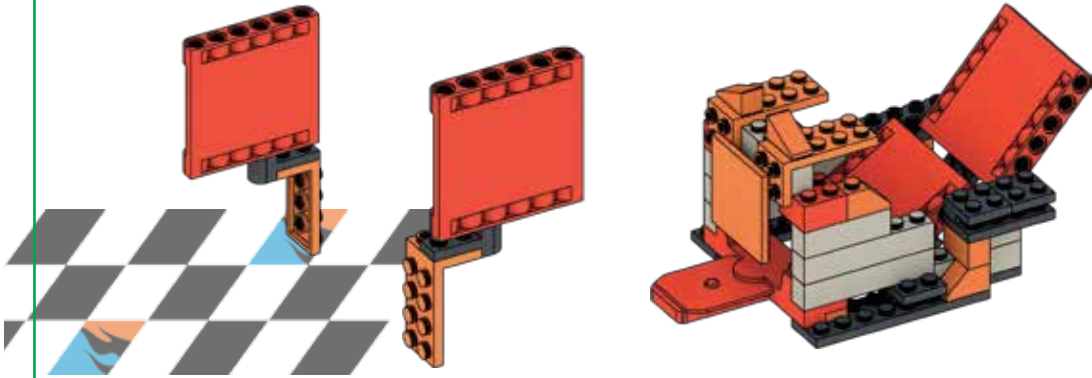

1.

2.

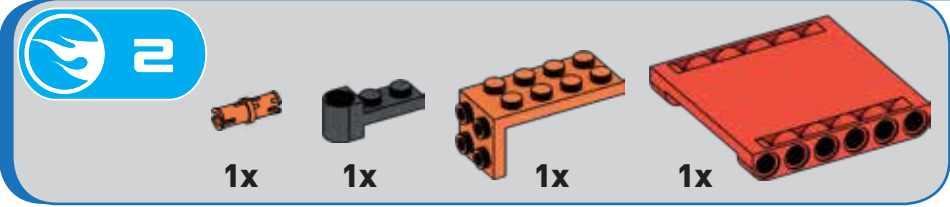
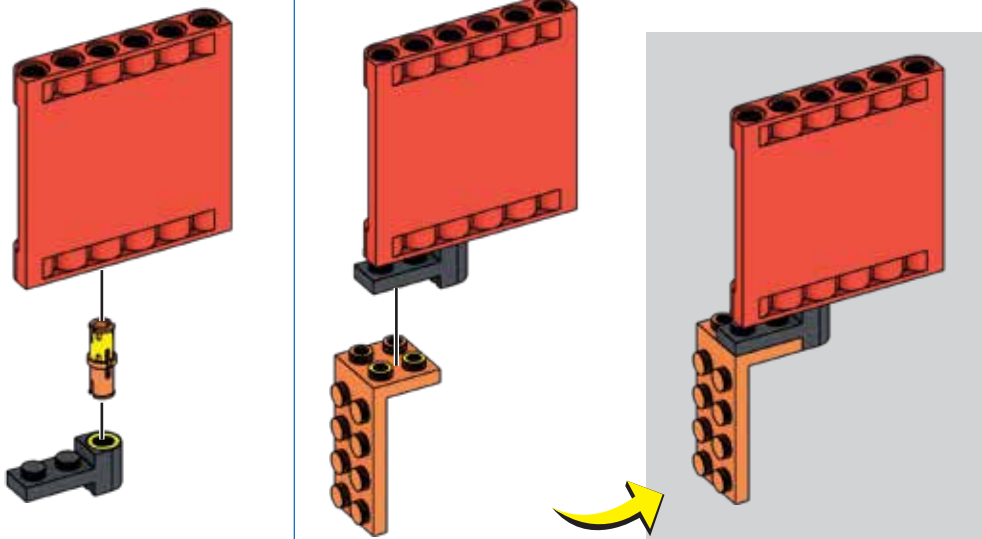

1.

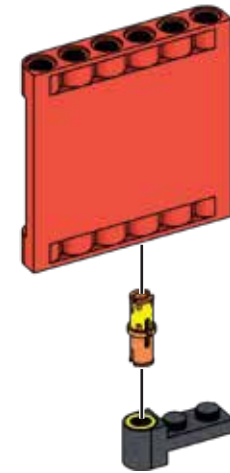

2.

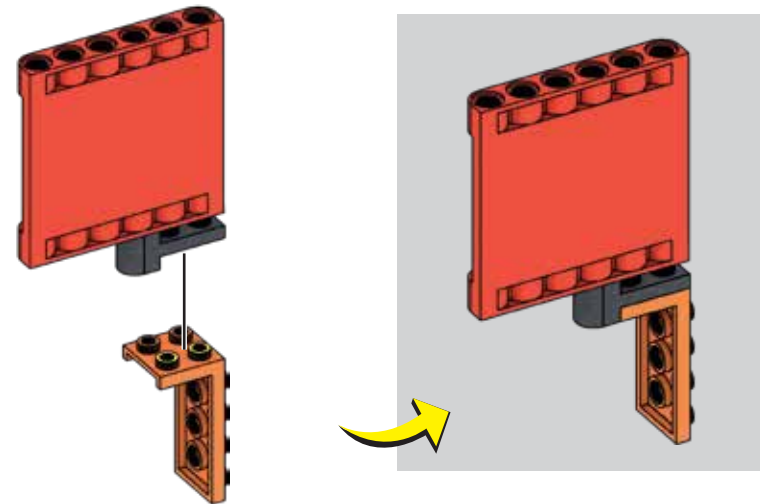

3

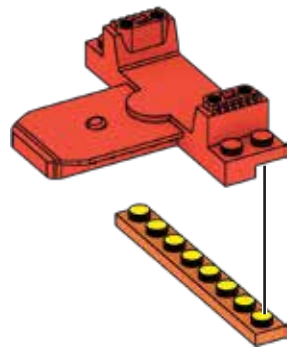
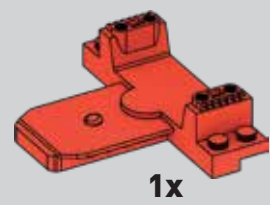

4

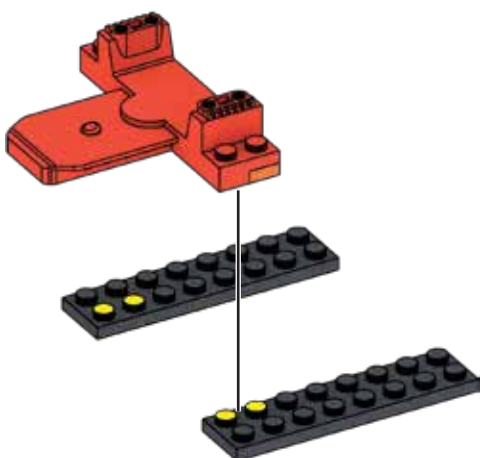

5

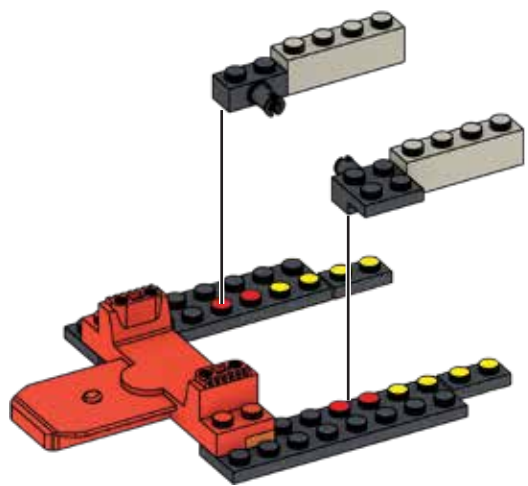

6

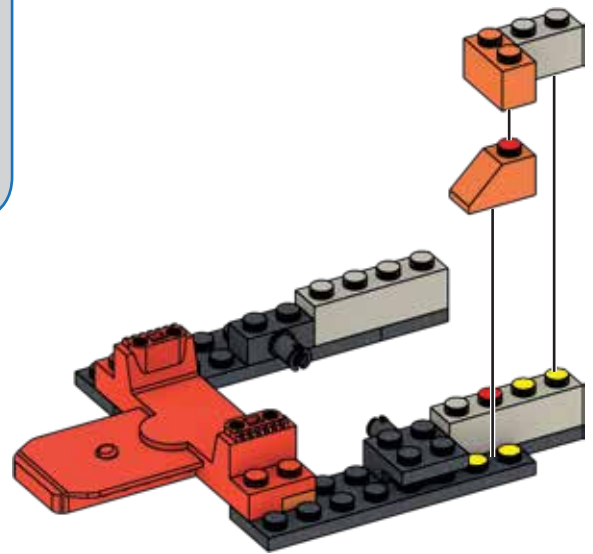

7

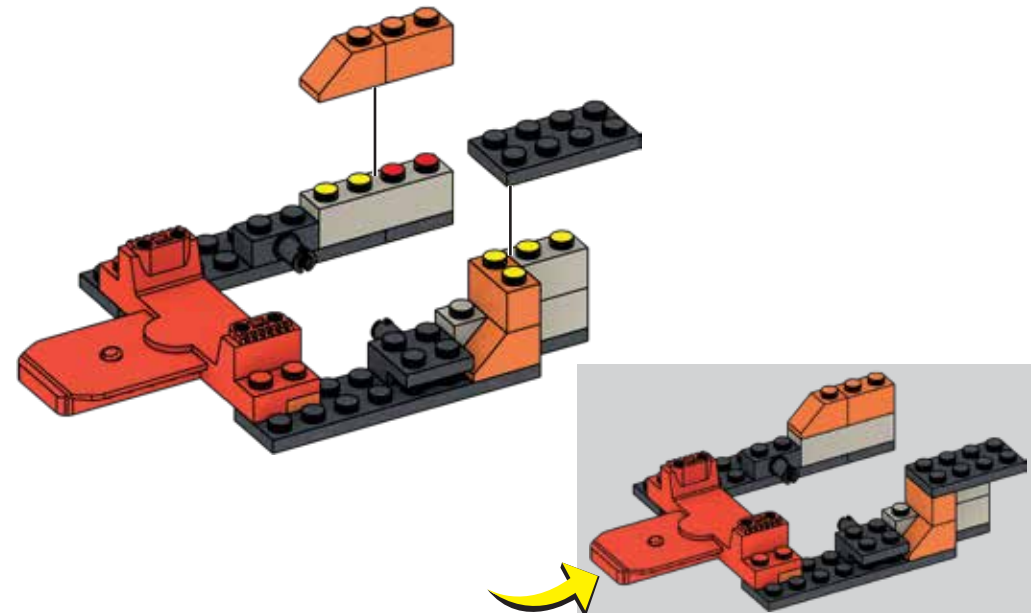

8

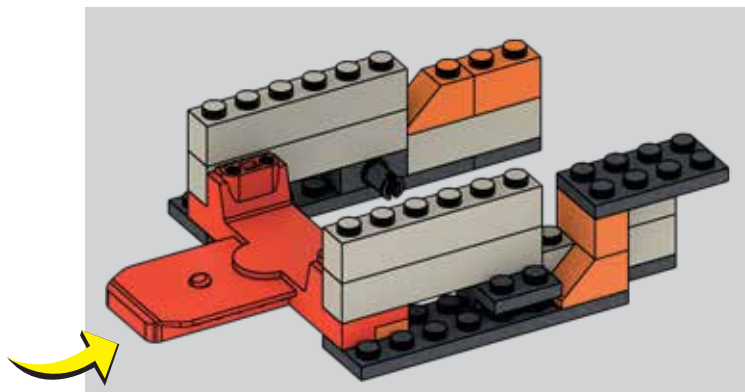
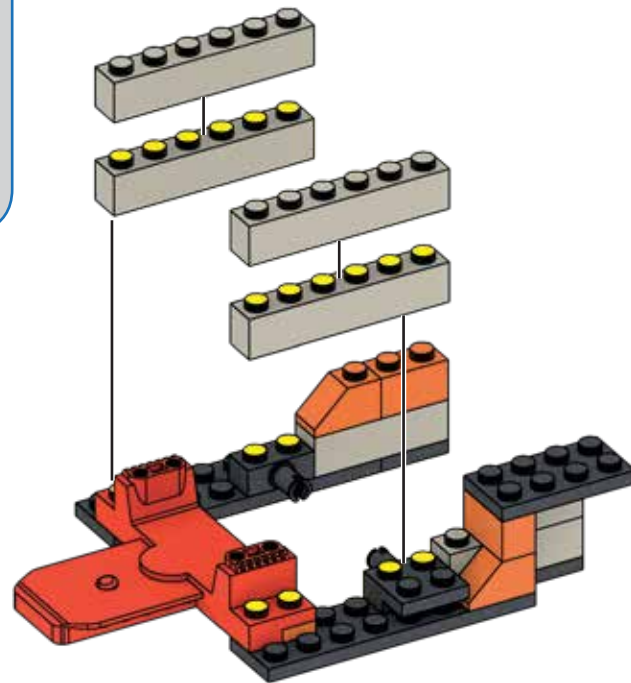
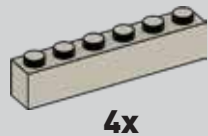

9

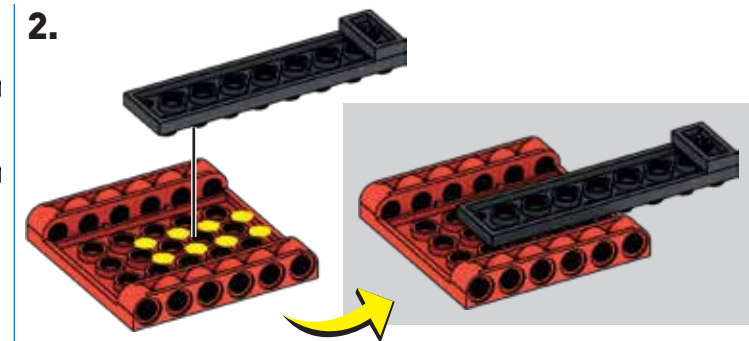
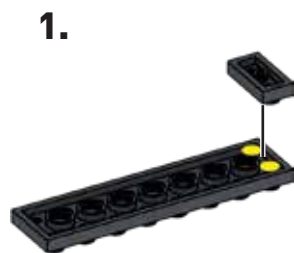

10

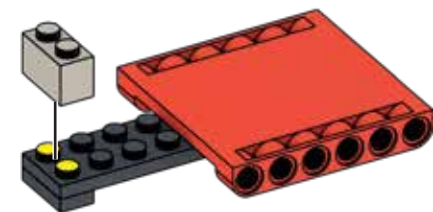

11

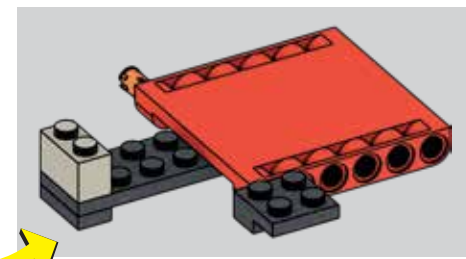
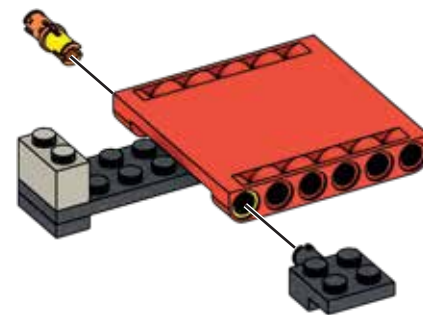

12

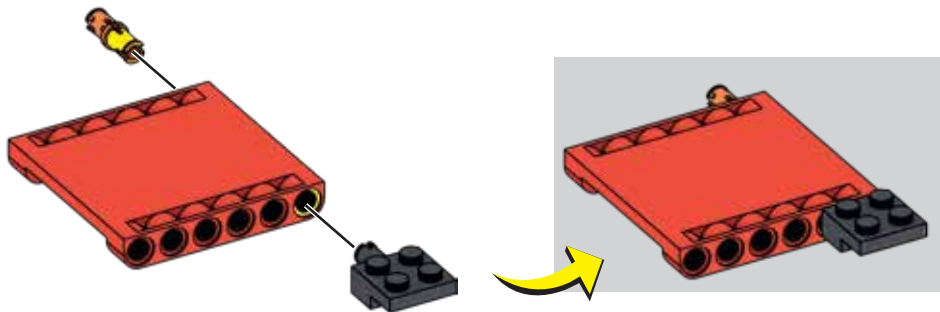
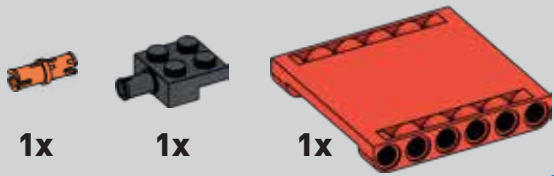

13

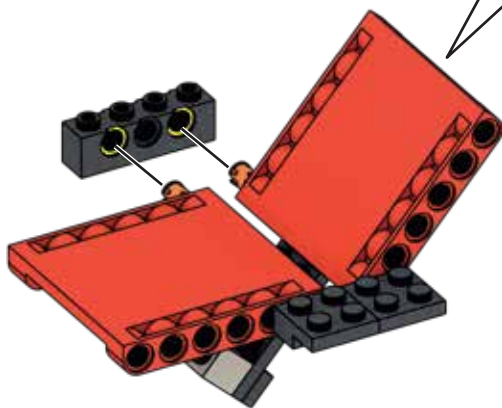

11

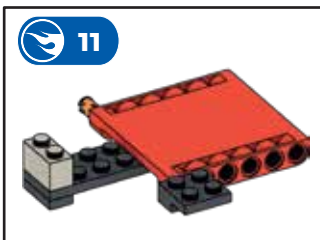

14

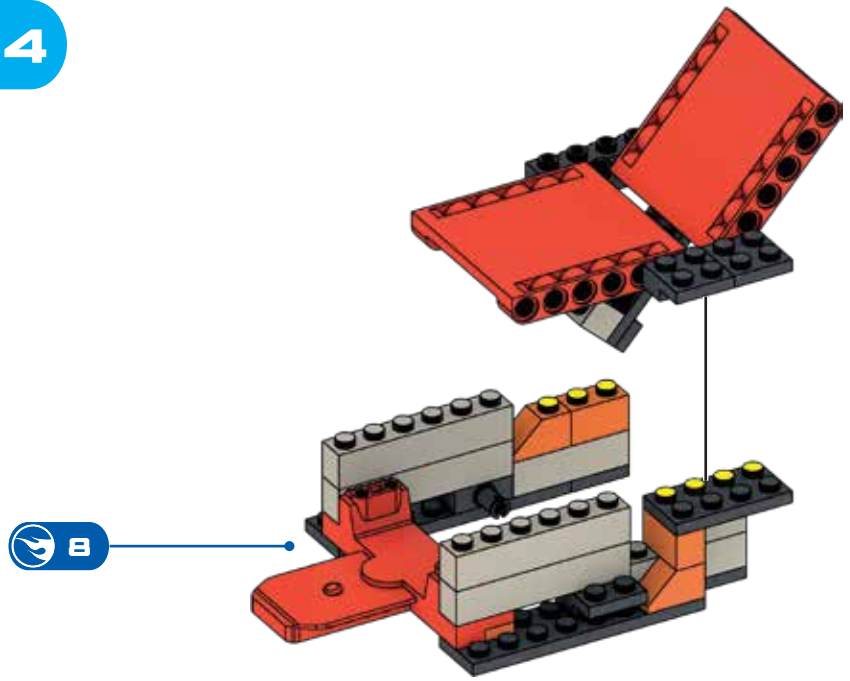

8

15

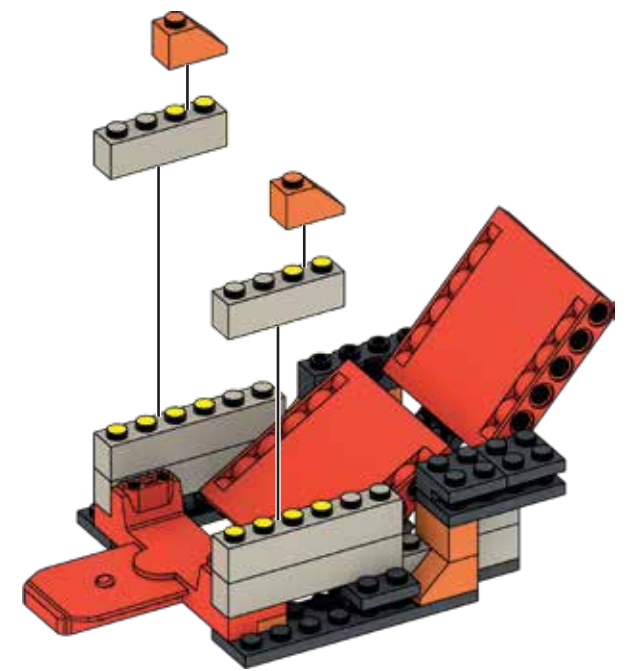

16

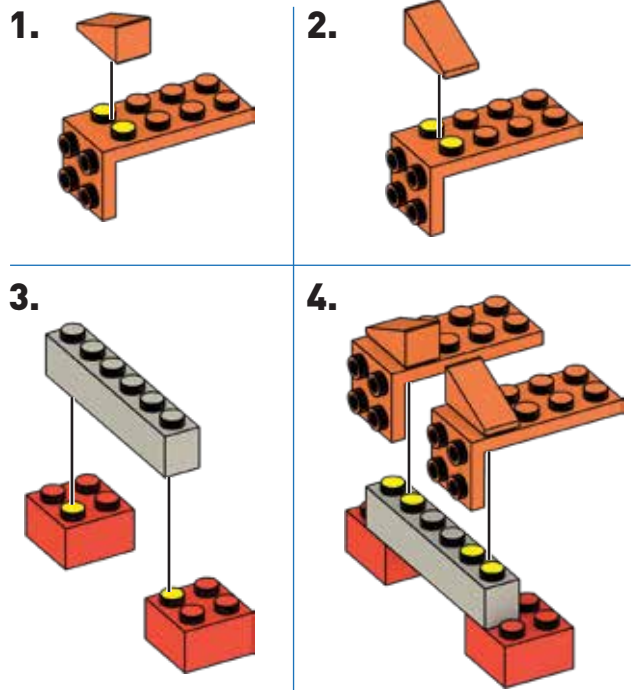
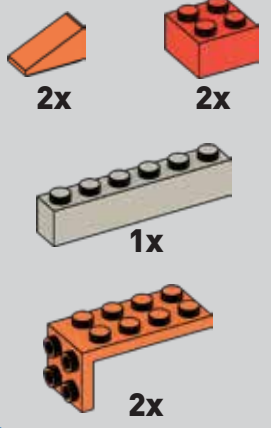

17

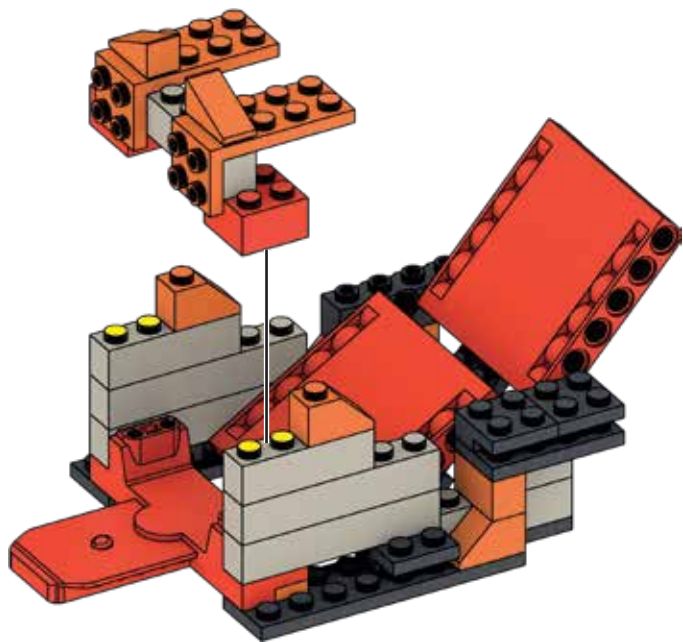

18

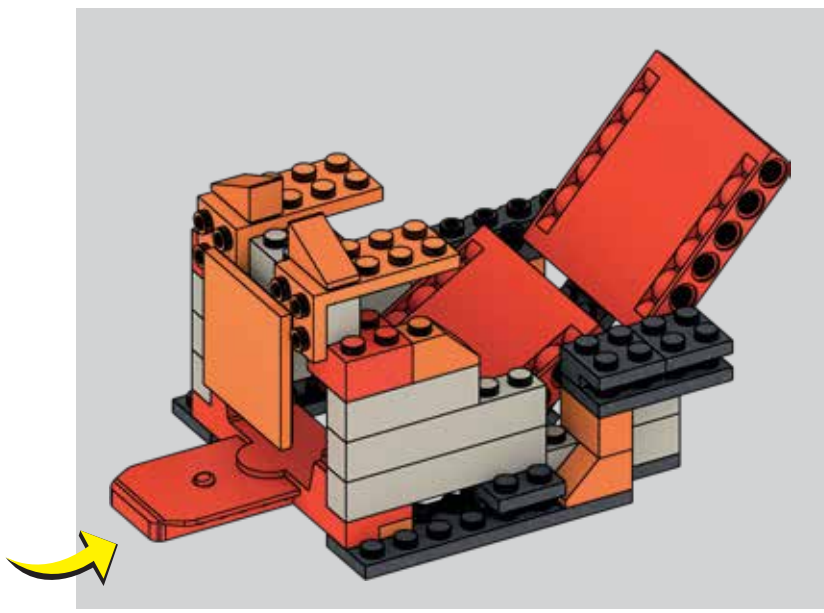
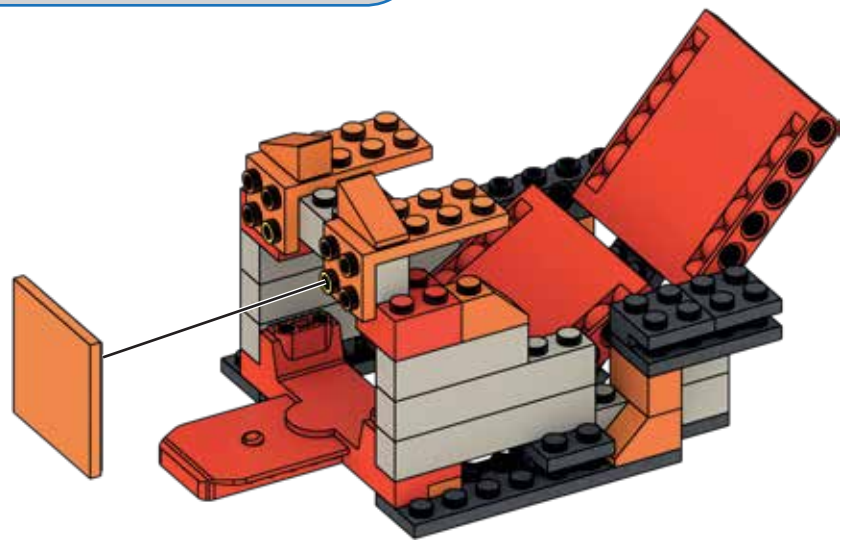
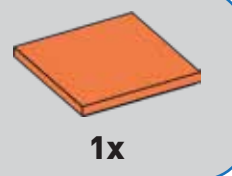

19

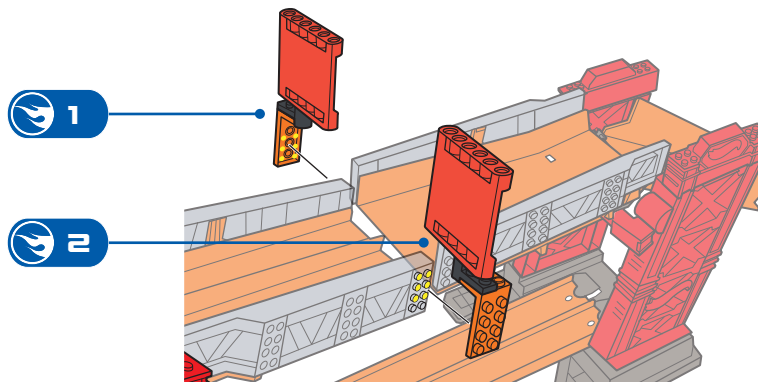

20

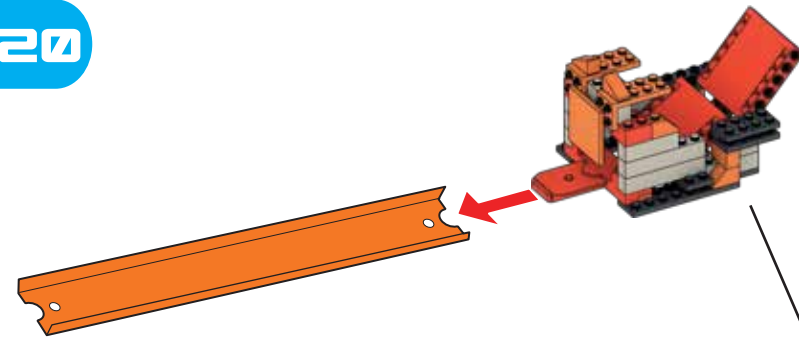

LAUNCH YOUR CAR! ILANZA EL AUTO! LANCE TA VOITURE! LANCE O CARRO!

POWER ON. • ENCIÉNDELO.
METTRE EN MARCHÉ. • LIGAR.

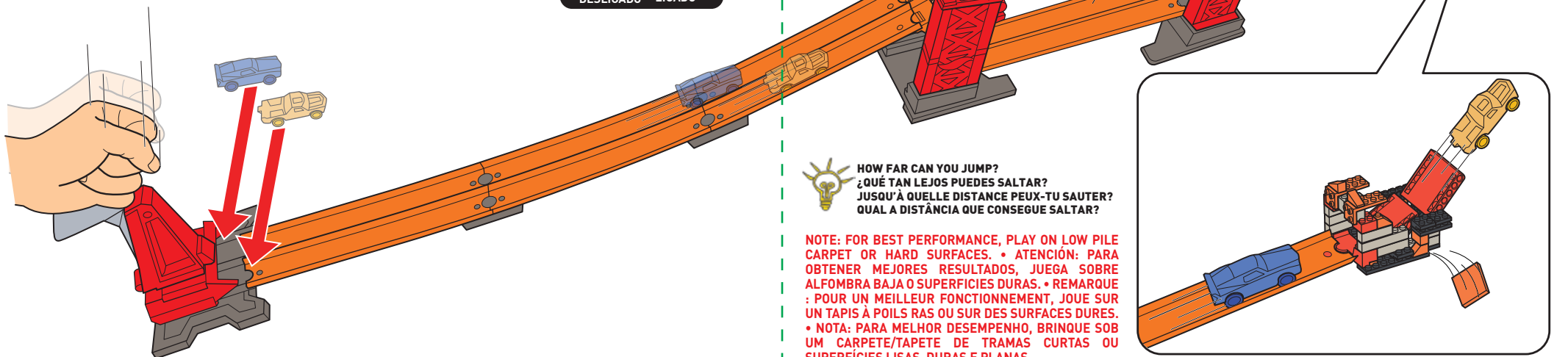

HOW FAR CAN YOU JUMP?
¿QUÉ TAN LEJOS PUEDES SALTAR?
JUSQU'À QUELLE DISTANCE PEUX-TU SAUTER?
QUAL A DISTÂNCIA QUE CONSEGUE SALTAR?

NOTE: FOR BEST PERFORMANCE, PLAY ON LOW PILE CARPET OR HARD SURFACES. • ATENCIÓN: PARA OBTENER MEJORES RESULTADOS, JUEGA SOBRE ALFOMBRA BAJA O SUPERFICIES DURAS. • REMARQUE : POUR UN MEILLEUR FONCTIONNEMENT, JOUE SUR UN TAPIS À POILS RAS OU SUR DES SURFACES DURES. • NOTA: PARA MELHOR DESEMPENHO, BRINQUE SOB UM CARPETE/TAPETE DE TRAMAS CURTAS OU SUPERFÍCIES LISAS, DURAS E PLANAS.

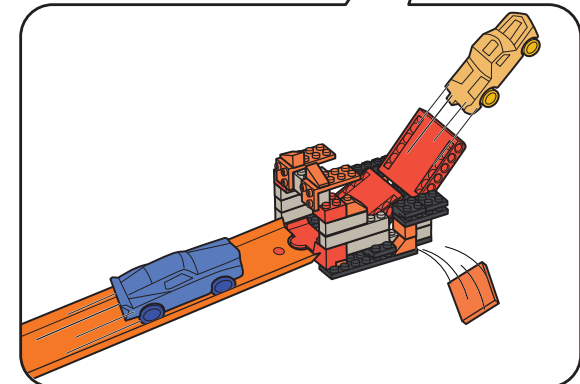

USE THE PACKAGE FOR STUNTS! • ÚSA LA CAJA PARA ACROBACIAS!
 UTILISE LA BOÎTE POUR CRÉER DES CASCADERES!
 USE A EMBALAGEM PARA MANOBRAS!

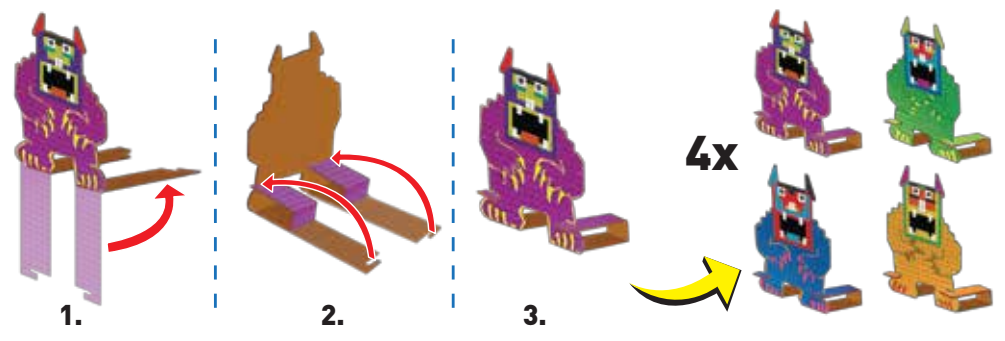
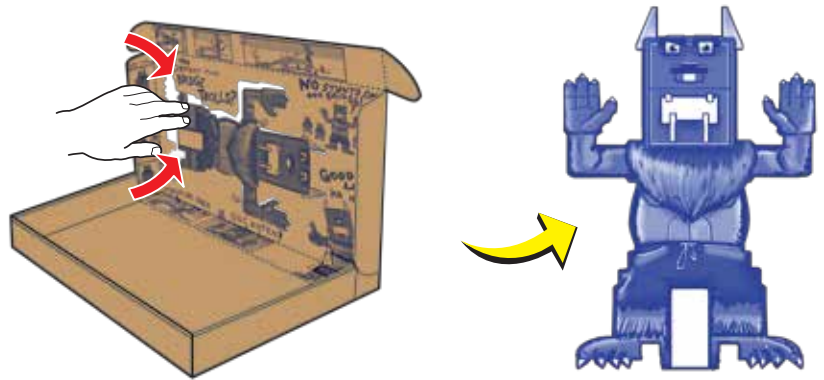

CAN YOU DEFEAT THE BRIDGE TROLLS?
 ¿PUEDES VENCER A LOS GNOMOS DEL PUENTE?
 PEUX-TU VAINCRE LES TROLLS DU PONT?
 CONSEGUE DERROTAR TROLLS DA PONTE?

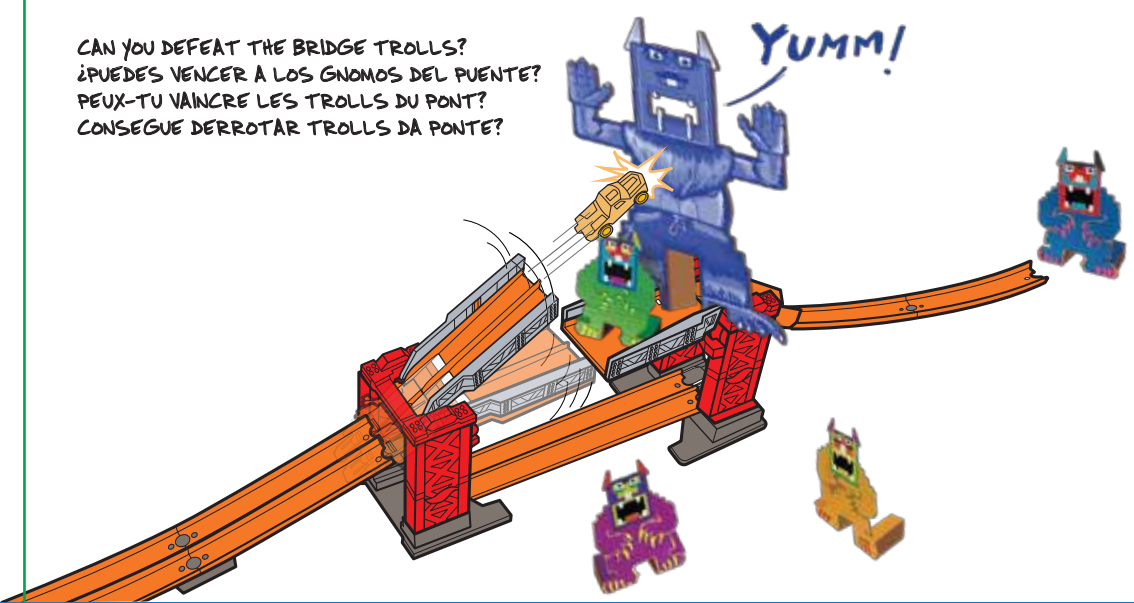

WHAT IF.....? • ¿Y SI...? • ET SI...? • E SE.....?

THE KEY TO A RAD STUNT IS IN YOUR HOME ALREADY:
 ...LA CLAVE A UNA INCREÍBLE ACROBACIA YA ESTÁ EN TU CASA?
 TU AS TOUT CE QU'IL FAUT À LA MAISON POUR CRÉER UNE SUPER CASCADERE :
 A CHAVE PARA UMA MANOBRRA RADICAL JÁ ESTÁ NA SUA CASA:

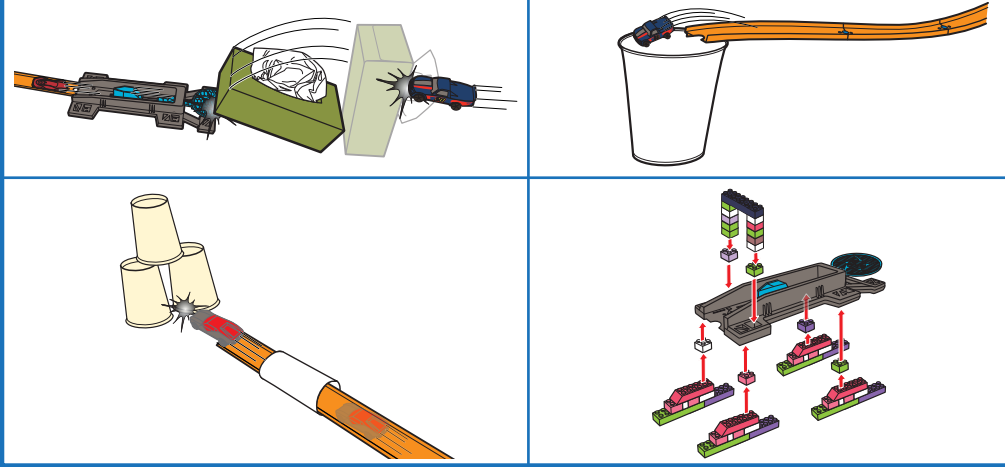

IMAGINE WHAT YOU COULD DO WITH THE TRACK BUILDER SYSTEM!
 IMAGÍNA TE TODAS LAS POSIBILIDADES CON EL SISTEMA TRACK BUILDER!
 IMAGINE TOUT CE QUE TU PEUX FAIRE AVEC LE SYSTÈME TRACK BUILDER!
 IMAGINE TODAS AS POSSIBILIDADES DO SISTEMA TRACK BUILDER!



WWW.HOTWHEELS.COM/TRACKBUILDER