

INSTRUCTIONS

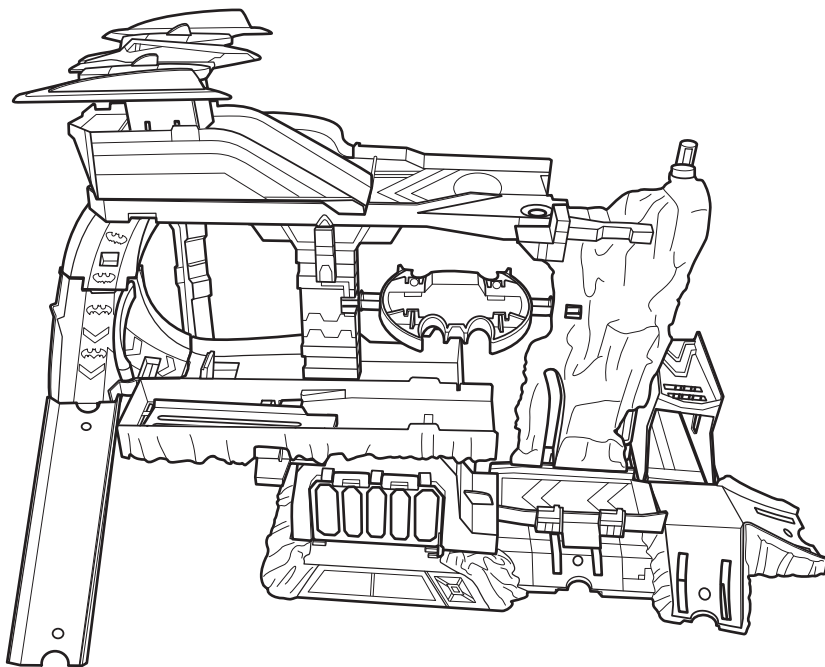

BATCAVE™



BATMAN and all related characters and elements © &™ DC Comics.
(s16)



DXC79-097061

service.mattel.com
HOTWHEELS.COM

PLEASE KEEP THESE INSTRUCTIONS FOR FUTURE
REFERENCE AS THEY CONTAIN IMPORTANT INFORMATION.

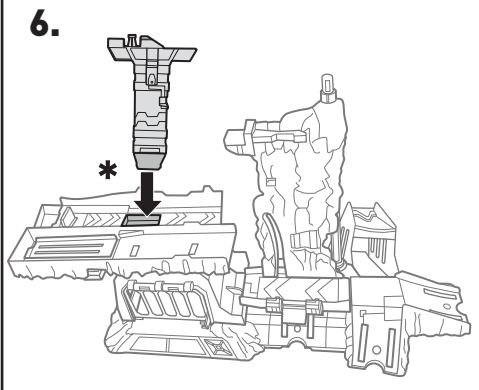
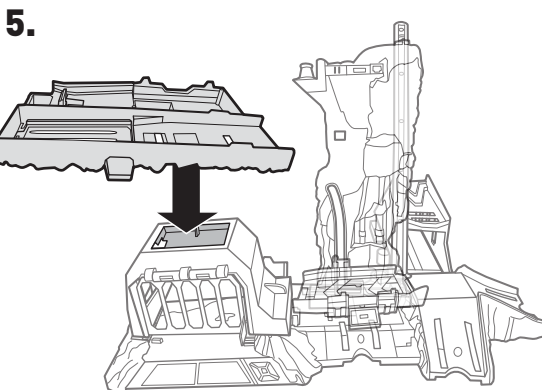
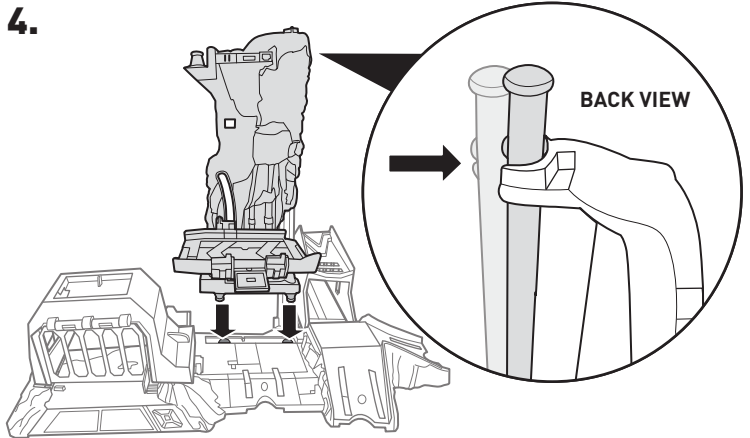
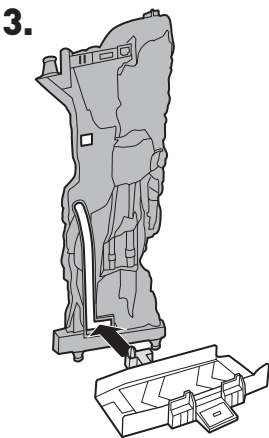
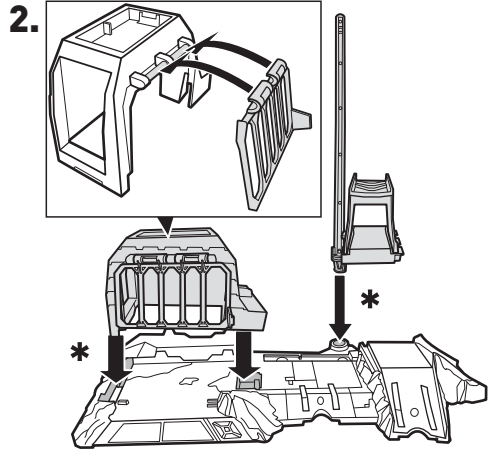
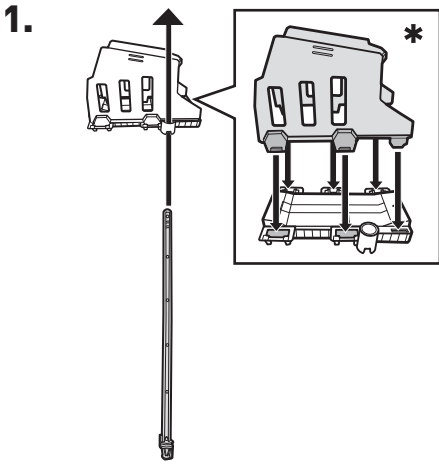

ASSEMBLY (CONTD.)

7.

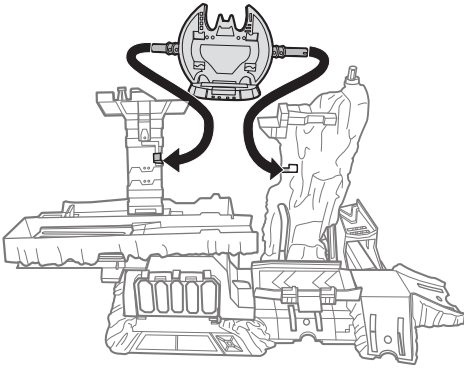

8.

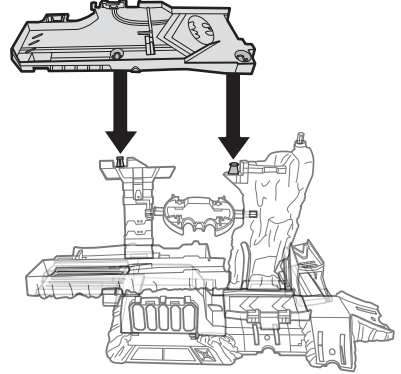

9.

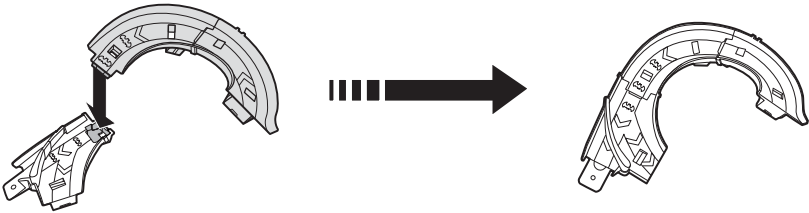

10.

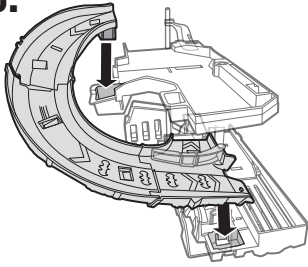

SIDE VIEW

*

11.

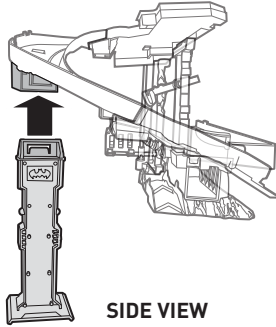

SIDE VIEW

12.

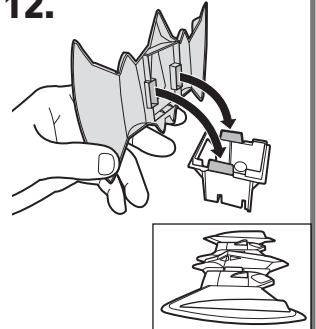

13.

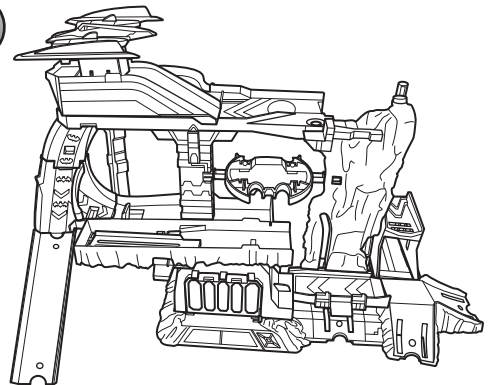
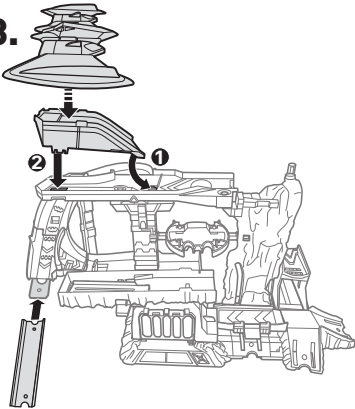

TO PLAY

1a. DRIVE VILLAIN UP THE LIFT!

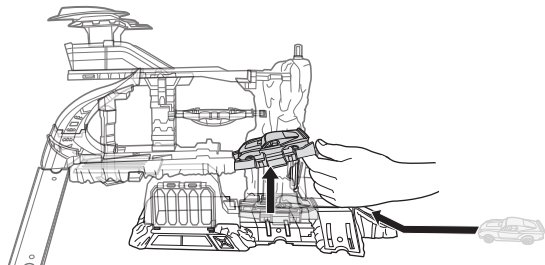

1 VEHICLE INCLUDED. OTHER VEHICLES SOLD SEPARATELY.

1b. SNEAK INTO THE BATCAVE™!

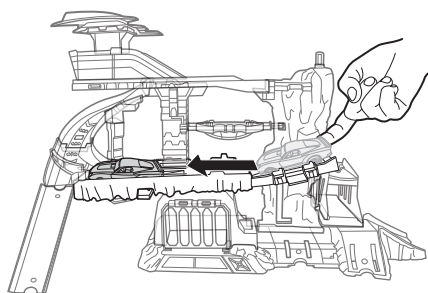

2a. BATMAN™ RACES BACK INTO THE BATCAVE™!

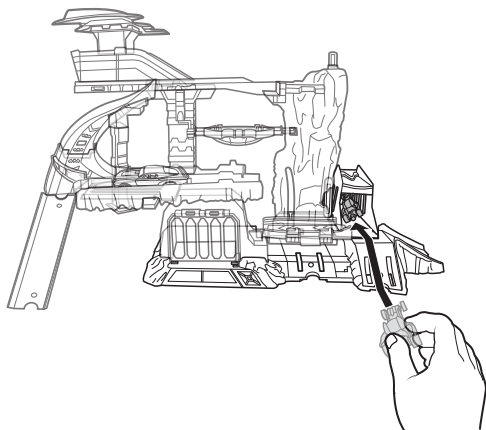

2b. MOVE UP TO THE TOP!

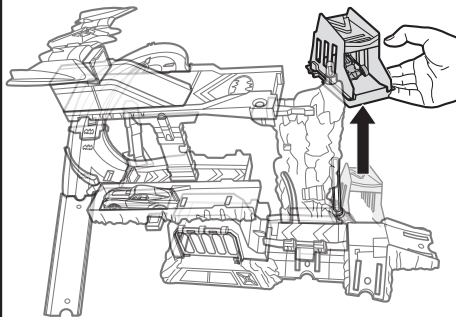

2c.

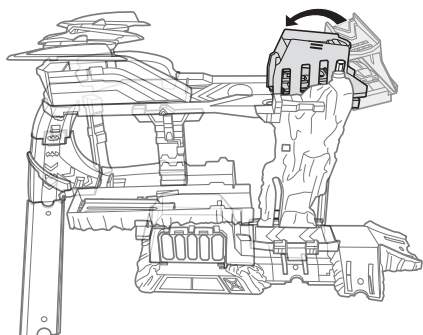

3. SPEED DOWN THE RAMP AND TRAP THE VILLAIN!

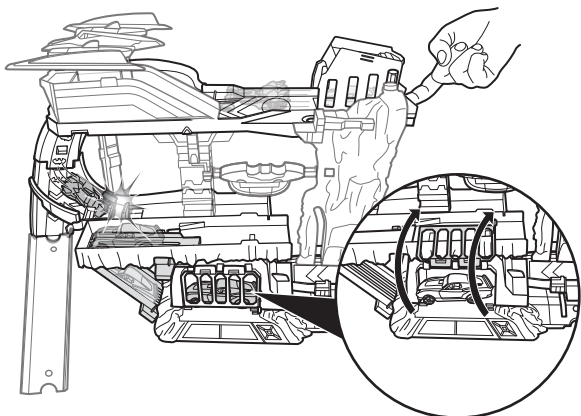

NOT FOR USE WITH SOME HOT WHEELS® VEHICLES.

TO PLAY (CONTD.)

4. "SCAN" VILLAIN ON *BATCOMPUTER*™!

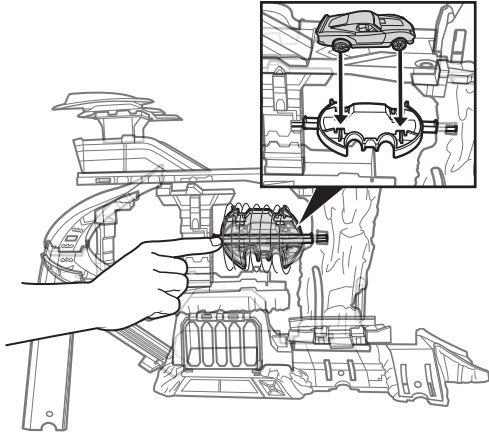

NOT FOR USE WITH SOME HOT WHEELS® VEHICLES.

5a. TRANSFORM TO *BATWING*™!

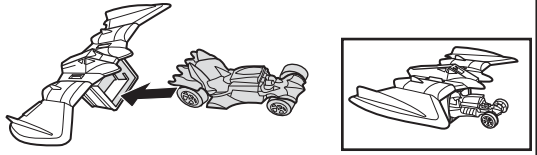

5b. FLY AND LAND ON RUNWAY!

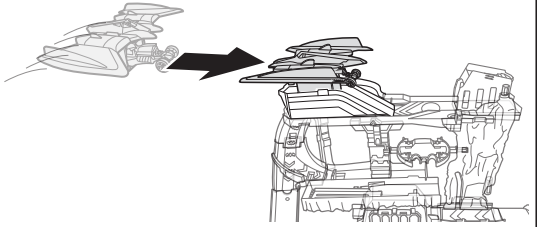

6. RACE OUT OF *BATCAVE*™ TO CATCH MORE VILLAINS!

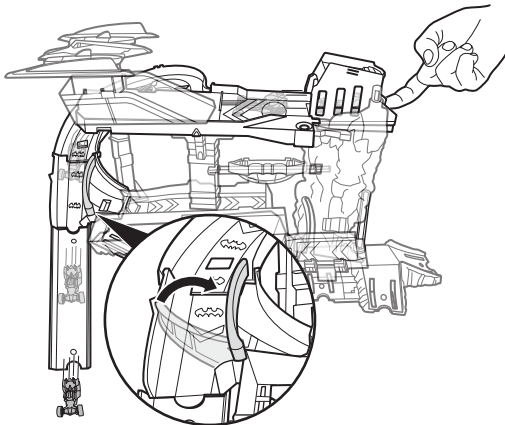

7. CONNECTS TO OTHER HOT WHEELS® SETS (SOLD SEPARATELY).

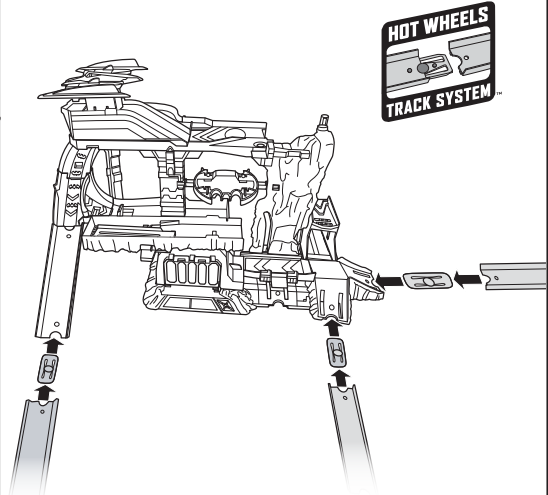

ADDITIONAL CONNECTORS AND TRACKS NOT INCLUDED.