

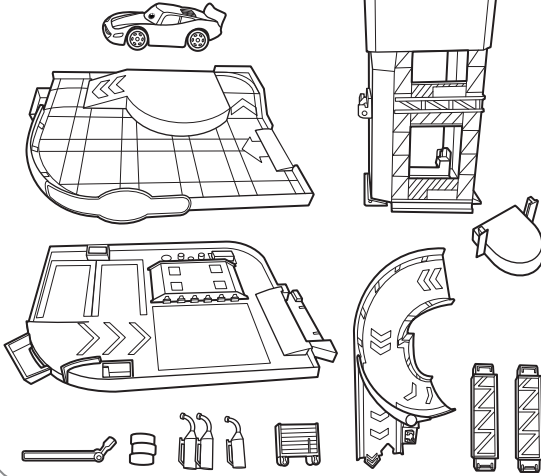

PISTON CUP RACING GARAGE INSTRUCTIONS

4+

CONTENTS



WARNING:
CHOKING HAZARD - Small parts.
Not for children under 3 years.

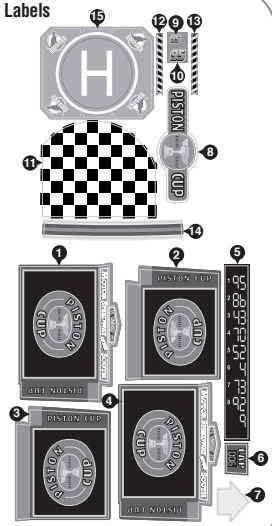

1 / APPLY LABELS

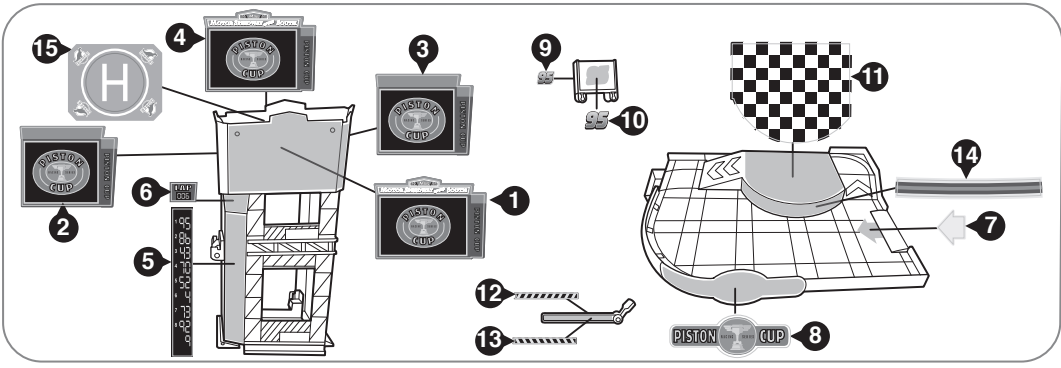

©2016 Mattel. All Rights Reserved. ® and ™ designate U.S. trademarks of Mattel, except as noted. Mattel, Inc., 636 Girard Avenue, East Aurora, NY 14052, U.S.A. Consumer Services 1-800-524-8697. Mattel U.K. Ltd., Vanwall Business Park, Maidenhead SL6 4UB. Helpline 01628 500303. Mattel Australia Pty., Ltd., Richmond, Victoria. 3121. Consumer Advisory Service - 1300 135 312. Mattel East Asia Ltd., Room 503-09, North Tower, World Finance Centre, Harbour City, Tsimshatsui, HK, China. Tel.: (852) 3185-6500. Diimport & Diedarkan Oleh: Mattel Southeast Asia Pte. Ltd., No 19-1, Tower 3 Avenue 7, Bangsar South City, No 8, Jalan Kerinchi, 59200 Kuala Lumpur, Malaysia. Tel: 03-78803817, Fax: 03-78803867.

2 / ASSEMBLY

1

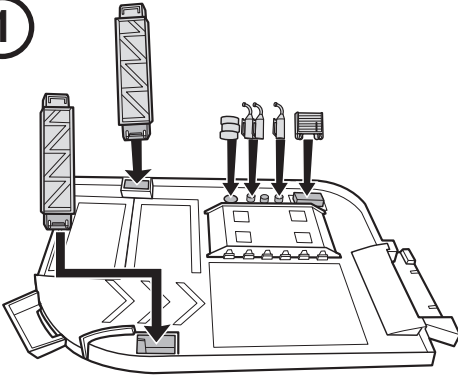

2

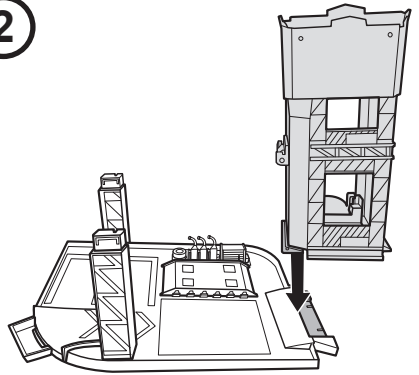

3

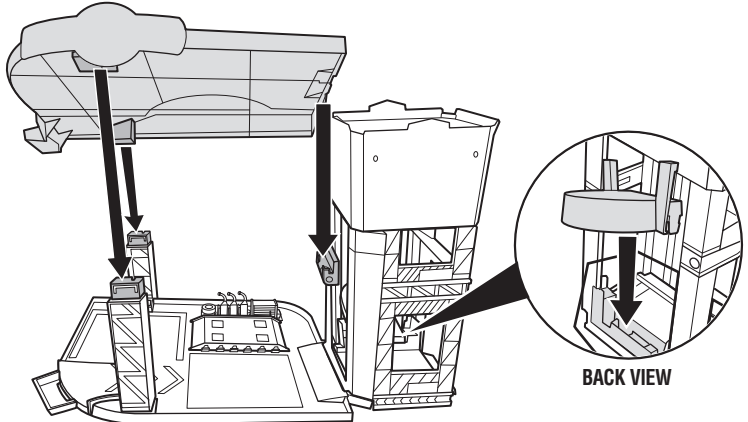

4

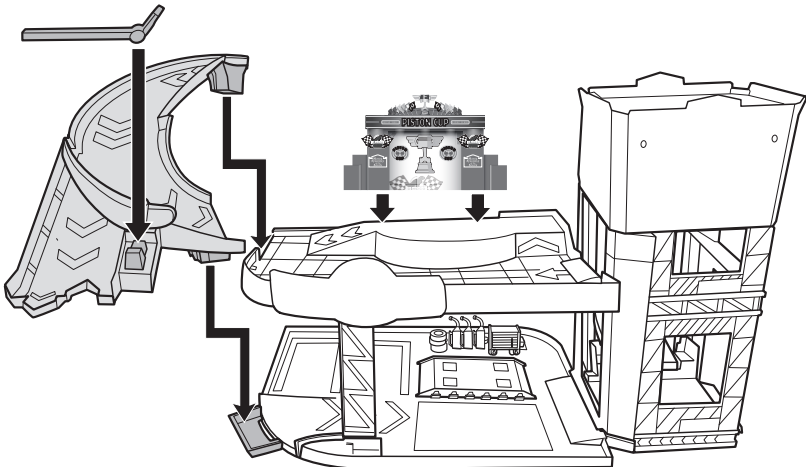

5

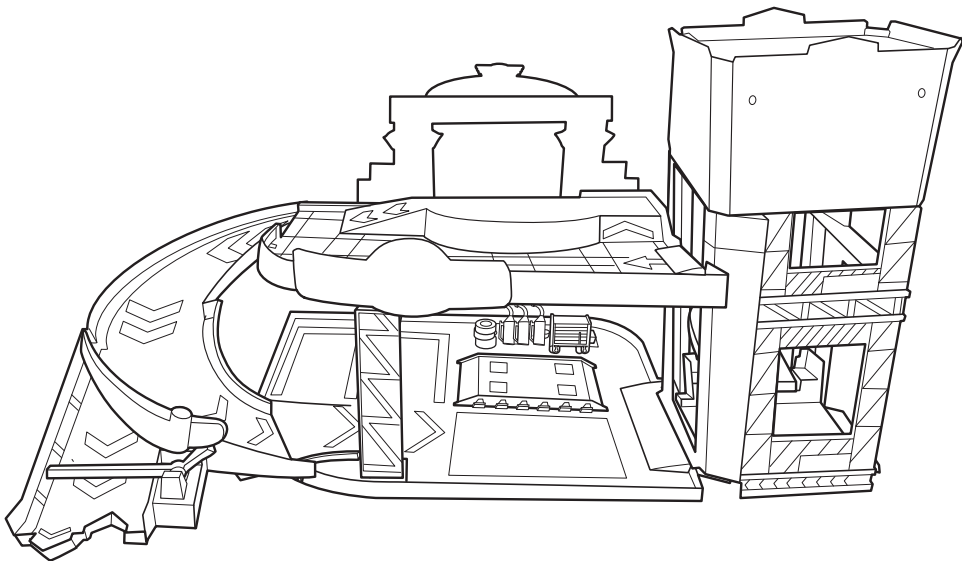

3 / LET'S PLAY

1 Drive into the elevator and move between 2 levels!

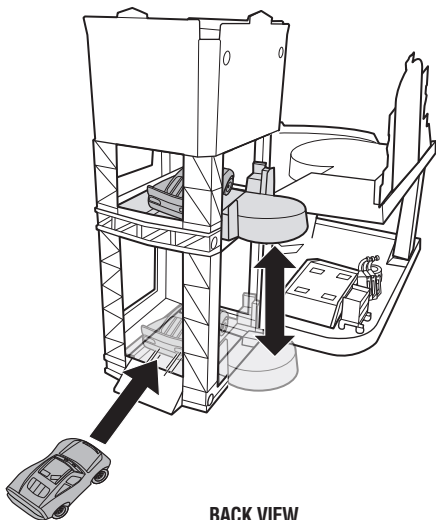

2 Drive on the Piston Cup Winner's Stage!

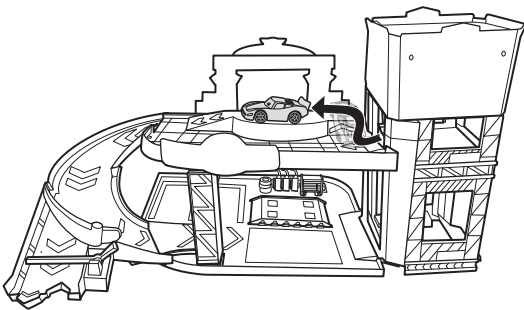

3 Roll down the ramp!

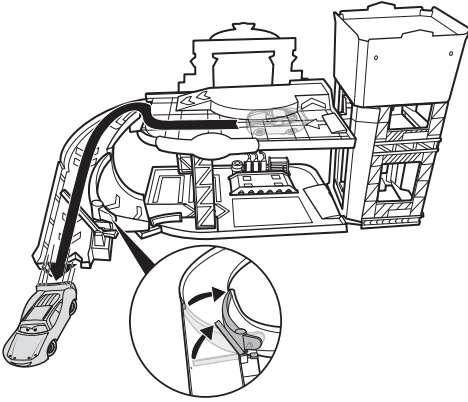

4 Roll down to the pit stop!

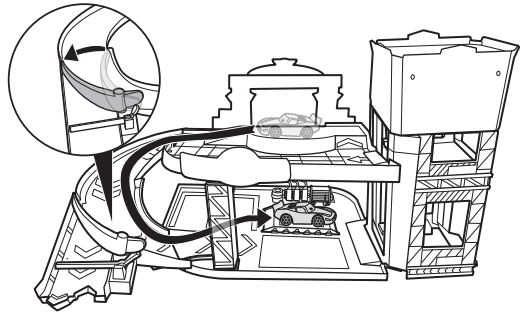

5 Park on the rooftop!

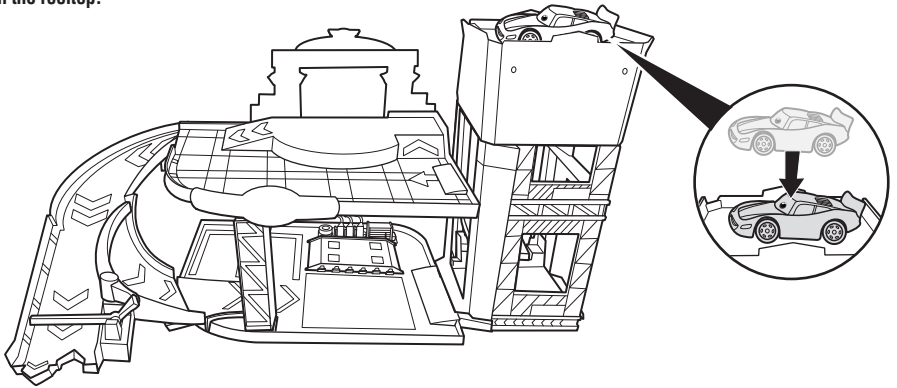

4 / COLLECT & CONNECT STORY SETS

Playsets with vehicles
each sold separately,
subject to availability.

