

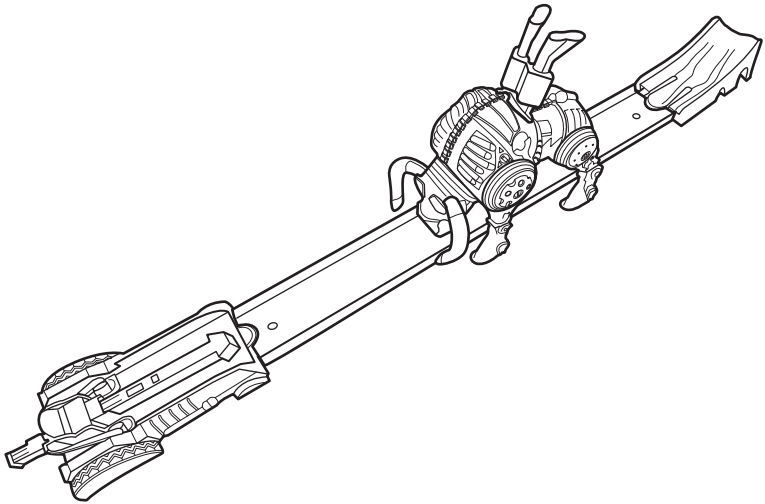

BULL RUN BATTLE™



NOT FOR USE WITH SOME HOT WHEELS® VEHICLES.

4+

service.mattel.com

HOTWHEELS.COM



ASST.DWK94 ASST.DYL99
FDF57-0970 FDT52-0970
1101107642-DOM 1101107642-DOM

PLEASE KEEP THESE INSTRUCTIONS FOR FUTURE REFERENCE AS THEY CONTAIN IMPORTANT INFORMATION.

CONTENTS

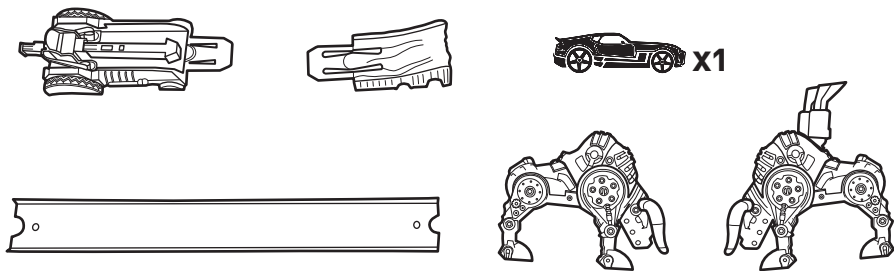

ASSEMBLY

1.

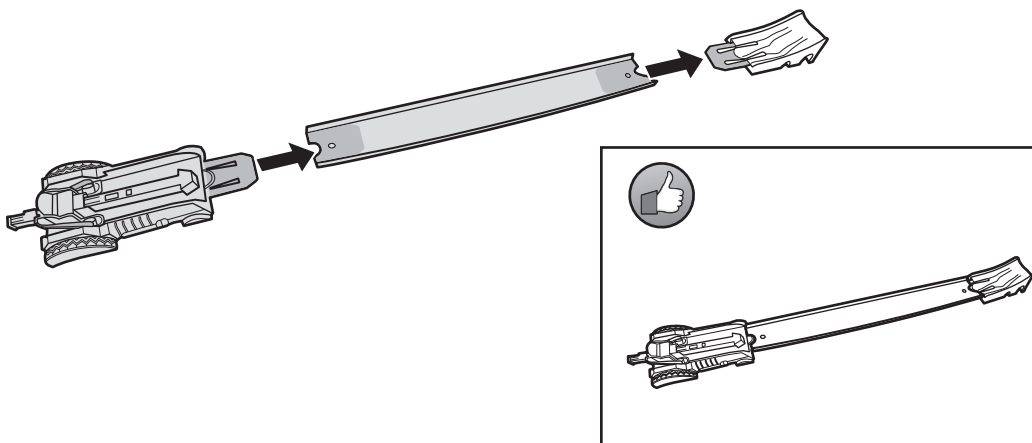

2.

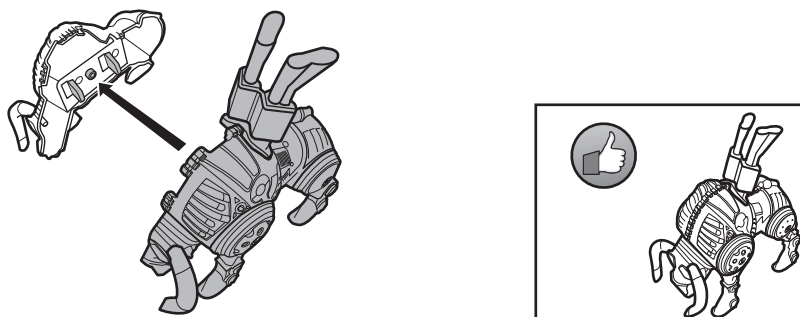

TO PLAY

1. POSITION THE BULL ANYWHERE ALONG THE TRACK.

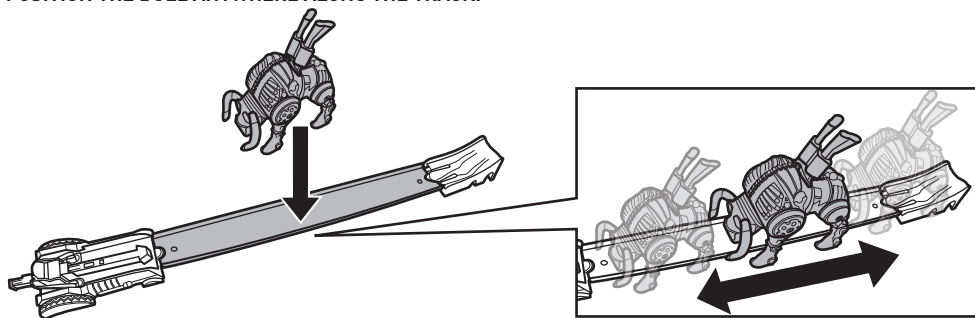

2. PULL BACK AND LOCK LAUNCHER INTO PLACE.

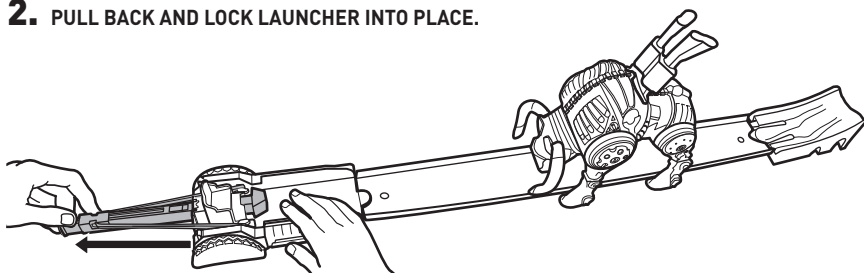

2-SPEED LAUNCHER

TRY DIFFERENT LAUNCH SETTINGS TO FIND THE BEST PERFORMANCE.

3. LOAD VEHICLE.

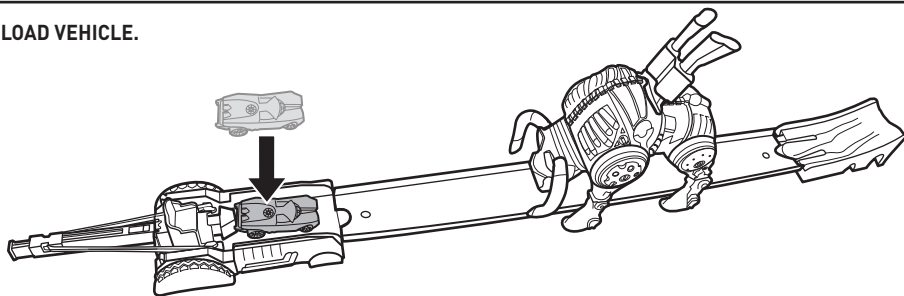

4. LAUNCH TO KNOCK THE BULL BACK!

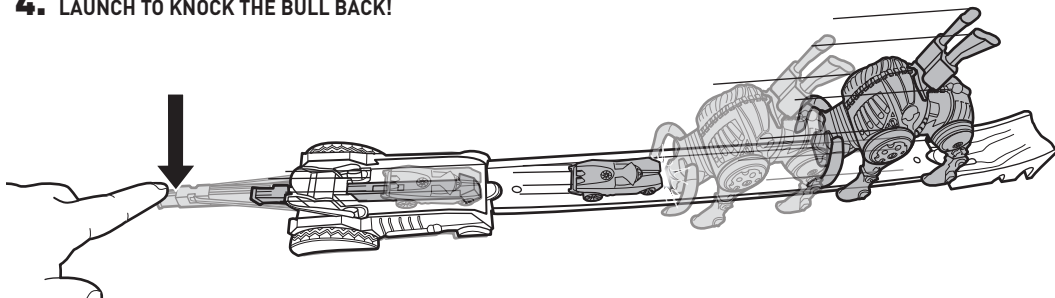

TO PLAY (CONTD.)

5. KEEP LAUNCHING UNTIL THE BULL IS KNOCKED PAST THE RAMP!

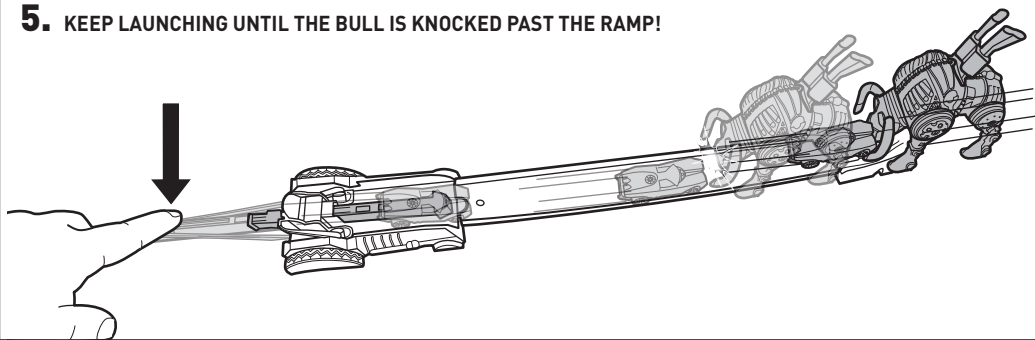

6. LAUNCH AGAIN. JUMP & HIT THE TRIGGER TO BLAST THE MECHANICAL BULL APART!

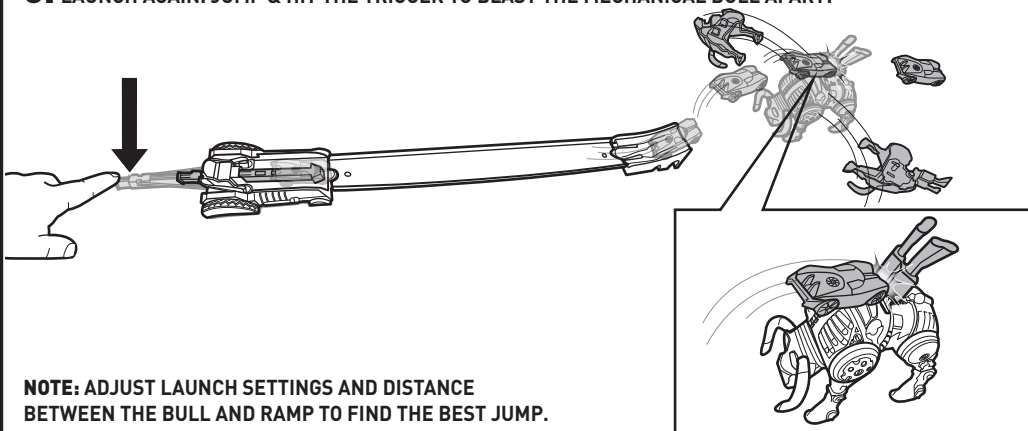

NOTE: ADJUST LAUNCH SETTINGS AND DISTANCE BETWEEN THE BULL AND RAMP TO FIND THE BEST JUMP.

REPLACE RUBBER BAND

1.

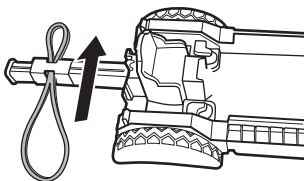

2.

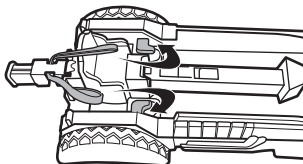

3.

