

**MISSION CONTROL & DIAGNOSTIC CENTER • CONTROL DE MISIONES Y CENTRO DE DIAGNÓSTICO
CENTRE DE CONTRÔLE ET DE DIAGNOSTIC**

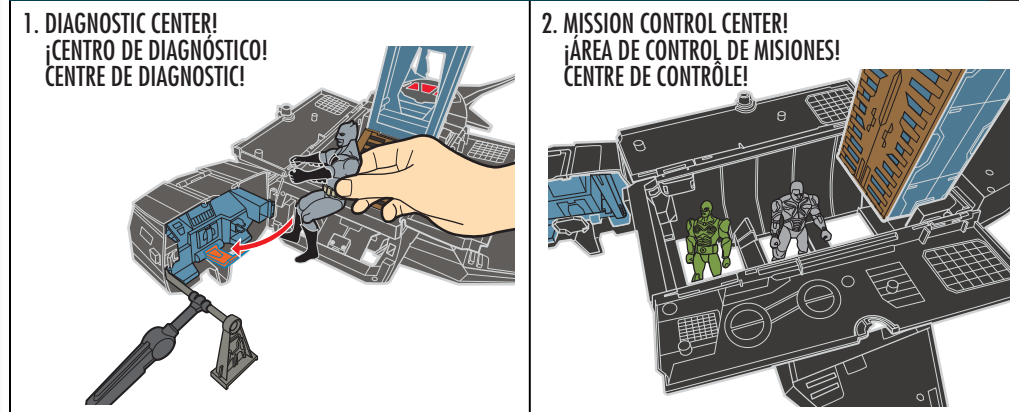

BATMAN™ AND CYBORG™
SOLD SEPARATELY, SUBJECT TO
AVAILABILITY.

BATMAN Y CYBORG SE VENDEN
POR SEPARADO Y ESTÁN SUJETOS
A DISPONIBILIDAD.

BATMAN ET CYBORG VENDUS
SÉPARÉMENT, SELON LA
DISPONIBILITÉ.

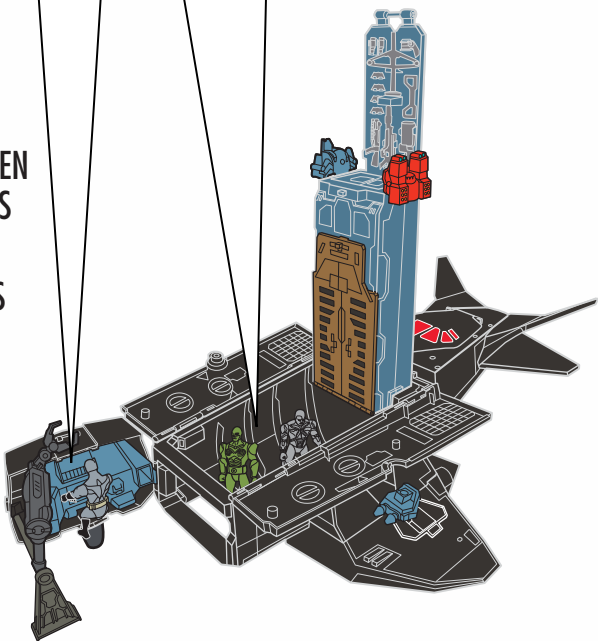

©2017 Mattel. All Rights Reserved. Tous droits réservés. * and ™ designate U.S. trademarks of Mattel, except as noted. * et ™ désignent des marques de Mattel aux États-Unis, sauf indication contraire. Mattel Australia Pty., Ltd., Richmond, Victoria. 3121. Consumer Advisory Service - 1300 135 312. Mattel East Asia Ltd., Room 503-09, North Tower, World Finance Centre, Harbour City, Tsimshatsui, HK, China. Tel.: (852) 3185-6500. Diimport & Diedarkan Oleh: Mattel Southeast Asia Pte. Ltd., No 19-1, Tower 3 Avenue 7, Bangsar South City, No 8, Jalan Kerinchi, 59200 Kuala Lumpur, Malaysia. Tel: 03-78803817, Fax: 03-78803867. Mattel, Inc. 636 Girard Avenue, East Aurora, NY 14052, U.S.A. Consumer Services 1-800-524-8697. Importado y distribuido por Mattel de México, S.A. de C.V., Miguel de Cervantes Saavedra No. 193, Pisos 10 y 11, Col. Granada, Delegación Miguel Hidalgo, C.P. 11520, México, D.F. R.F.C. MME-920701-NB3. Tels.: 59-05-51-00 Ext. 5206 ó 01-800-463-59-89. Mattel Chile, S.A., Avenida América Vespucio 501-B, Quilicura, Santiago. Tel.: 1230-020-6213. Servicio al consumidor Venezuela: Tel.: 0-800-100-9123. Mattel Argentina, S.A., Curupayti 1186, (1607) - Villa Adelina, Buenos Aires. Tel.: 0800-666-3373. Mattel Colombia, S.A., Calle 12347-07 P.5, Bogotá. Tel.: 01800-710-2069. Mattel Perú, S.A., Av. Juan de Arona # 151, Centro Empresarial Juan de Arona, Torre C, Piso 7, Oficina 704, San Isidro, Lima 27, Perú. RUC: 20425853865. Reg. Importador: 02350-12-JUE-DIGESA. Tel.: 0800-54744. E-mail Latinoamérica: servicio.clientes@mattel.com. Mattel Canada Inc., Mississauga, Ontario L5R 3W2. You may call us free at/ composez sans frais le 1-800-524-8697. Mattel Europa B.V., Gondel 1, 1186 MJ Amstelveen, Nederland. Mattel South Africa (PTY) LTD, Office 102 B, 30 Melrose Boulevard, Johannesburg 2196.

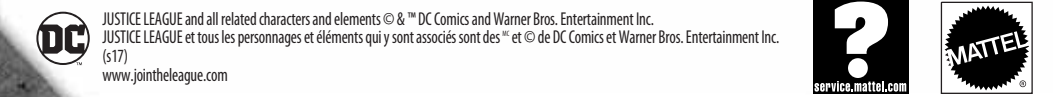

DC JUSTICE LEAGUE
**INSTRUCTIONS
INSTRUCCIONES
MODE D'EMPLOI**



WARNING:
CHOKING HAZARD - Small parts.
Not for children under 3 years.

ADVERTENCIA:
PELIGRO DE ASFIXIA. Juguete no recomendado
para menores de 3 años. Contiene piezas pequeñas que
podrían provocar asfixia en caso de ser ingeridas por el niño/a.

ATTENTION:
DANGER D'ÉTOUFFEMENT -
Petits éléments. Ne convient pas aux
enfants de moins de 36 mois.

**COLORS AND DECORATIONS MAY VARY. • LOS COLORES Y DECORACIÓN PUEDEN VARIAR DE LOS MOSTRADOS.
LES COULEURS ET LES MOTIFS PEUVENT VARIER.**

FIGURES NOT INCLUDED. • FIGURAS NO INCLUIDAS. • FIGURINES NON INCLUSES.

**PLEASE KEEP THESE INSTRUCTIONS FOR FUTURE REFERENCE AS THEY CONTAIN IMPORTANT INFORMATION. • LEE
Y GUARDA ESTAS INSTRUCCIONES PARA FUTURA REFERENCIA, YA QUE CONTIENEN INFORMACIÓN DE
IMPORTANCIA DE ESTE PRODUCTO. • CONSERVER CE MODE D'EMPLOI POUR S'Y RÉFÉRER AU BESOIN, CAR IL
CONTIENT DES INFORMATIONS IMPORTANTES.**



CONTENTS • CONTENIDO • CONTENU 3

ASSEMBLY • MONTAJE • ASSEMBLAGE 4-5

APPLY LABELS • PEGA LAS CALCOMANÍAS • APPLICATION DES AUTOCOLLANTS 6-11

VEHICLE MODE • MODALIDAD DE VEHÍCULO • MODE VÉHICULE 6-7

PLAYSET MODE • MODALIDAD DE ESCENARIO • MODE COFFRET DE JEU 8-11

TO PLAY: VEHICLE MODE • PARA JUGAR: MODALIDAD DE VEHÍCULO • POUR JOUER: MODE VÉHICULE 12-15

TO PLAY: TRANSFORM INTO PLAYSET • PARA JUGAR: TRANSFORMA EN ESCENARIO
POUR JOUER : TRANSFORMATION EN COFFRET DE JEU 16-17

TO PLAY: PLAYSET MODE • PARA JUGAR: MODALIDAD DE ESCENARIO
POUR JOUER : MODE COFFRET DE JEU 18-24

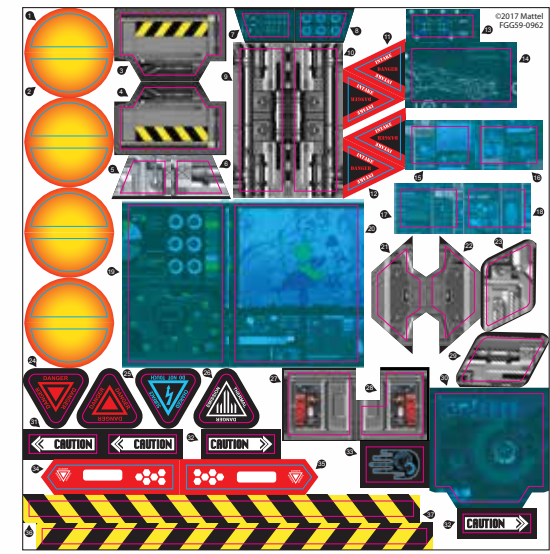
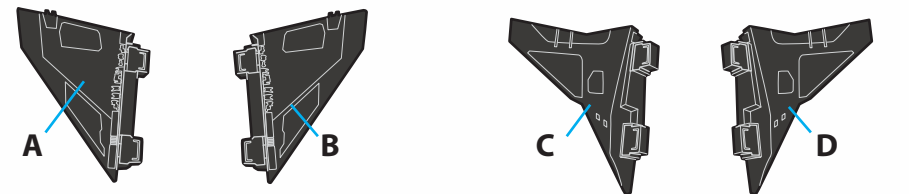
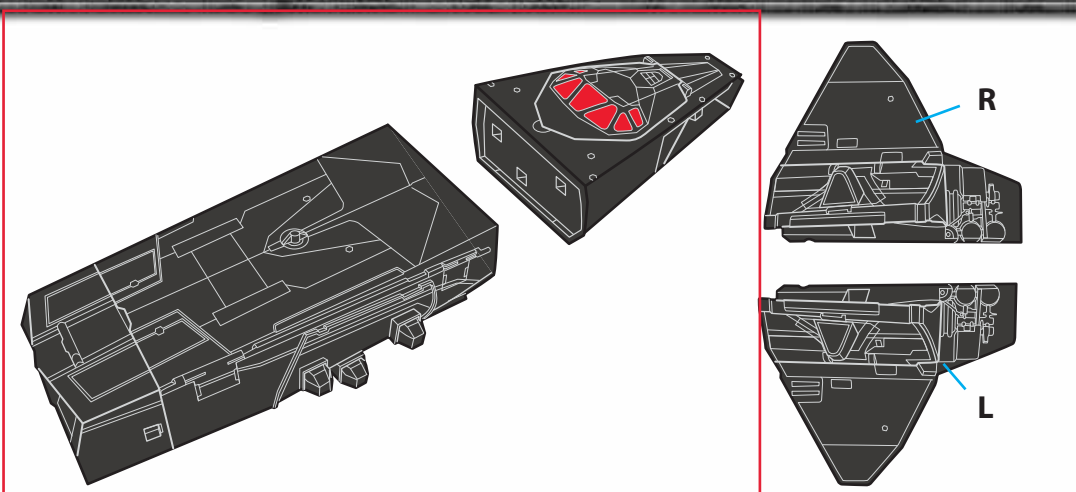

LABEL SHEET • HOJA DE CALCOMANÍAS • FEUILLE D'AUTOCOLLANTS

**WEAPONS & ACCESSORIES • ARMAS Y ACCESORIOS
ARMES ET ACCESSOIRES**

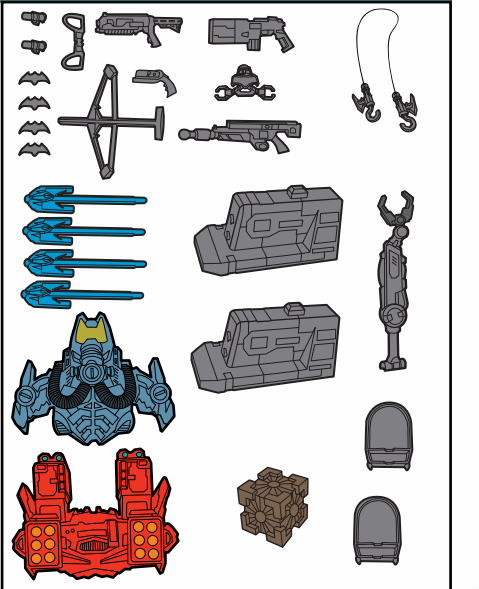

REFER TO LETTERS ON TOY PARTS TO HELP WITH ASSEMBLY.
VE LAS LETRAS EN LAS PIEZAS PARA FACILITAR EL MONTAJE.
POUR FACILITER L'ASSEMBLAGE, SE RÉFÉRER AUX LETTRES SUR LES PIÈCES.

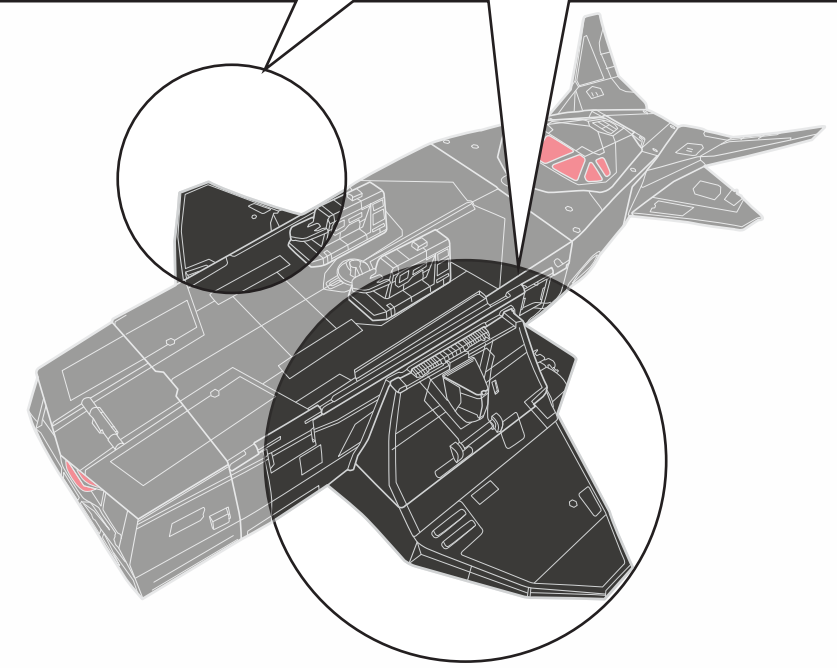
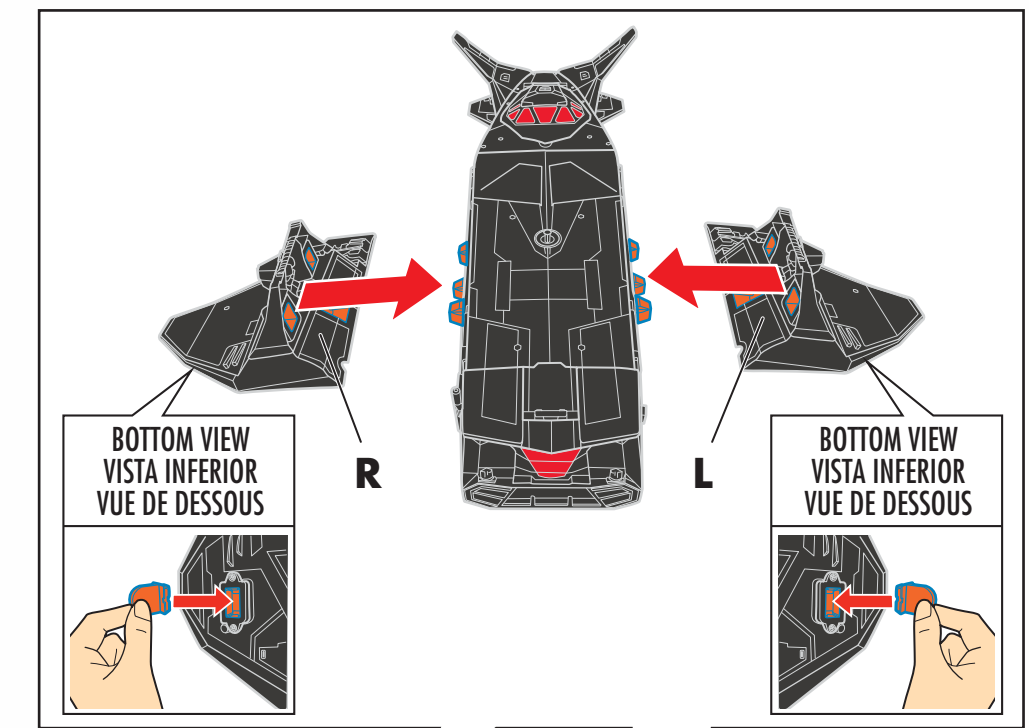
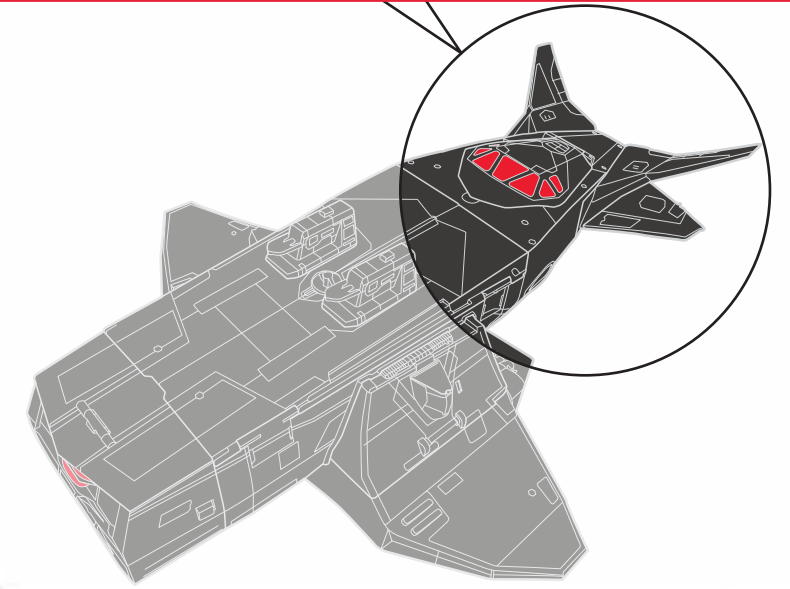
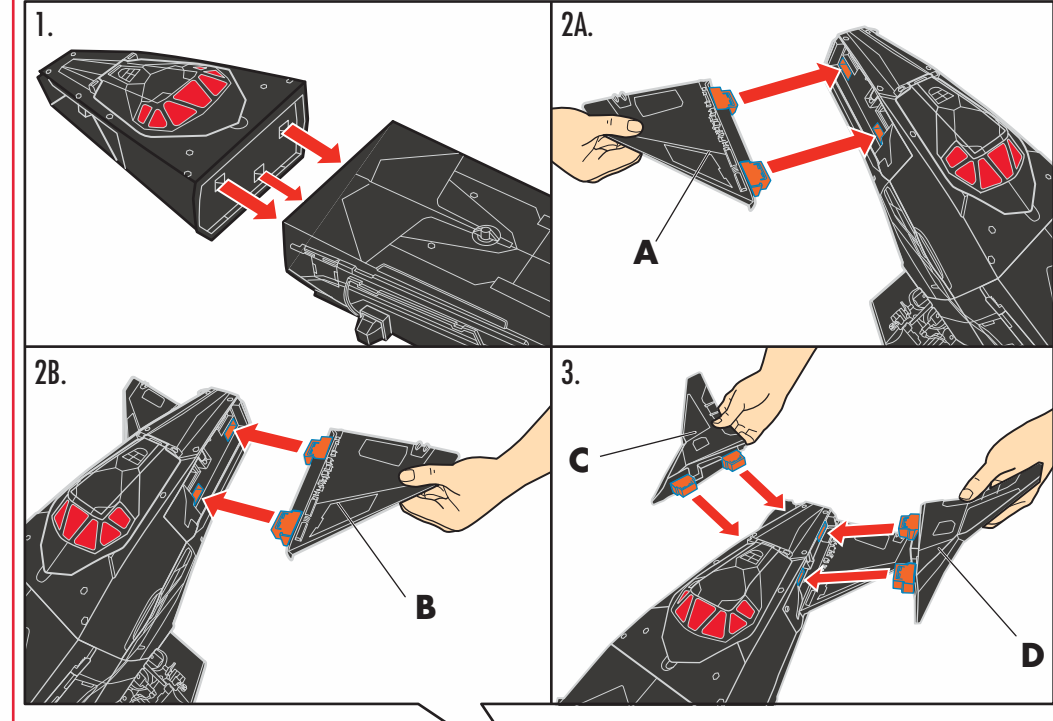

VEHICLE MODE • MODALIDAD DE VEHÍCULO • MODE VÉHICULE

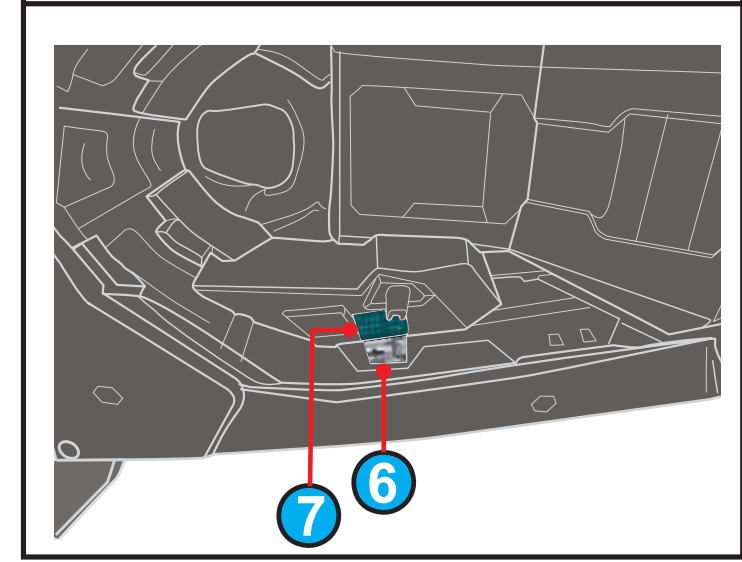
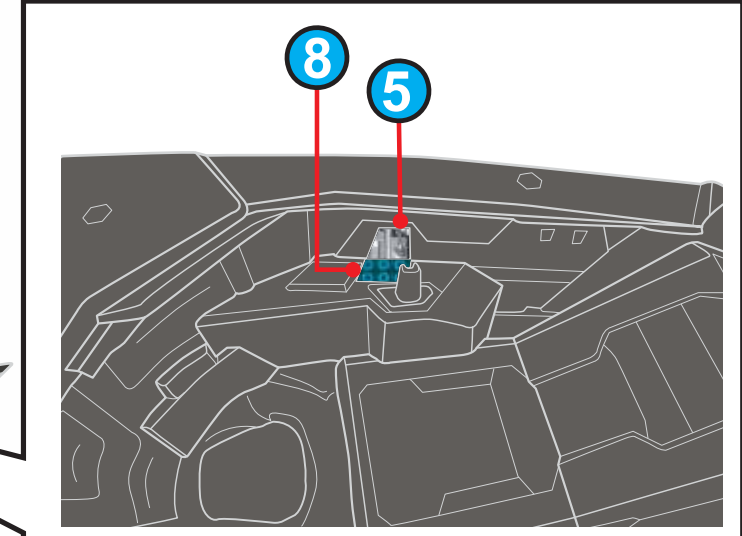
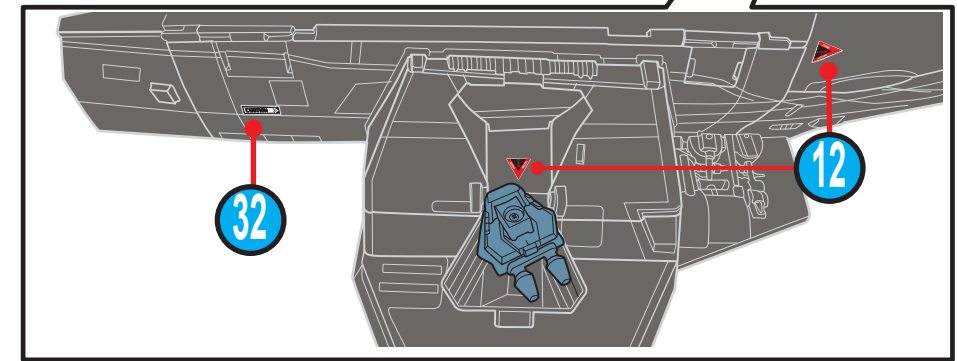
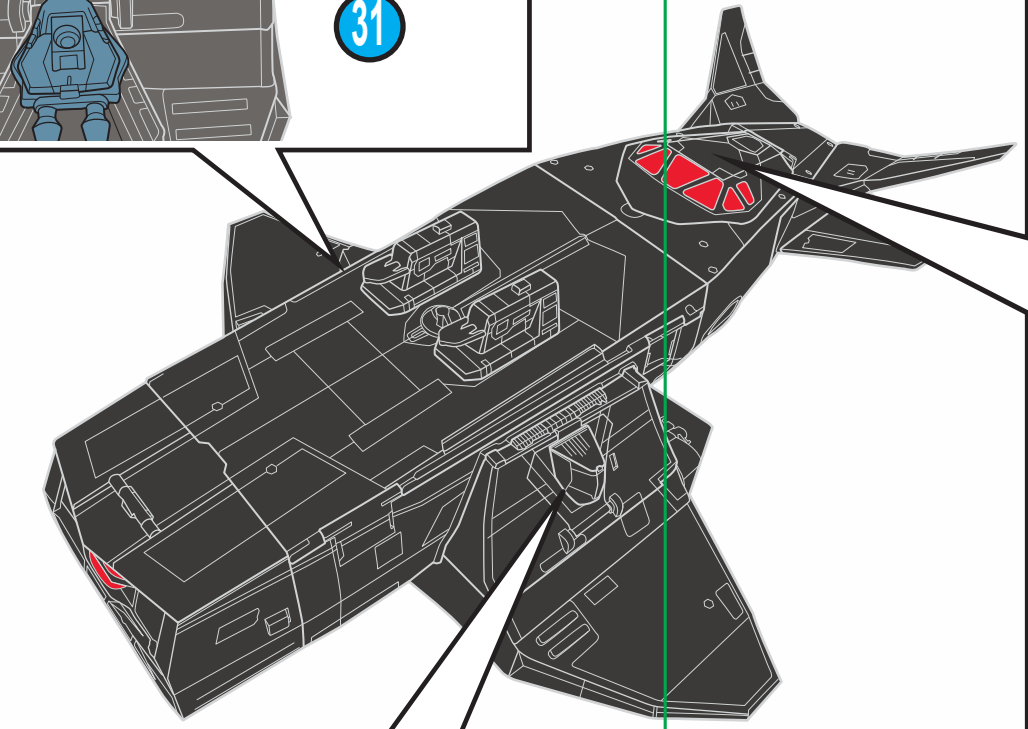
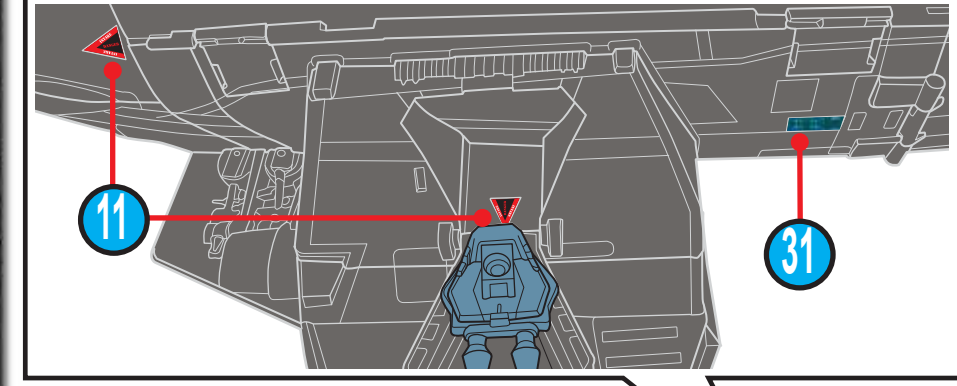

PLAYSET MODE • MODALIDAD DE ESCENARIO • MODE COFFRET DE JEU

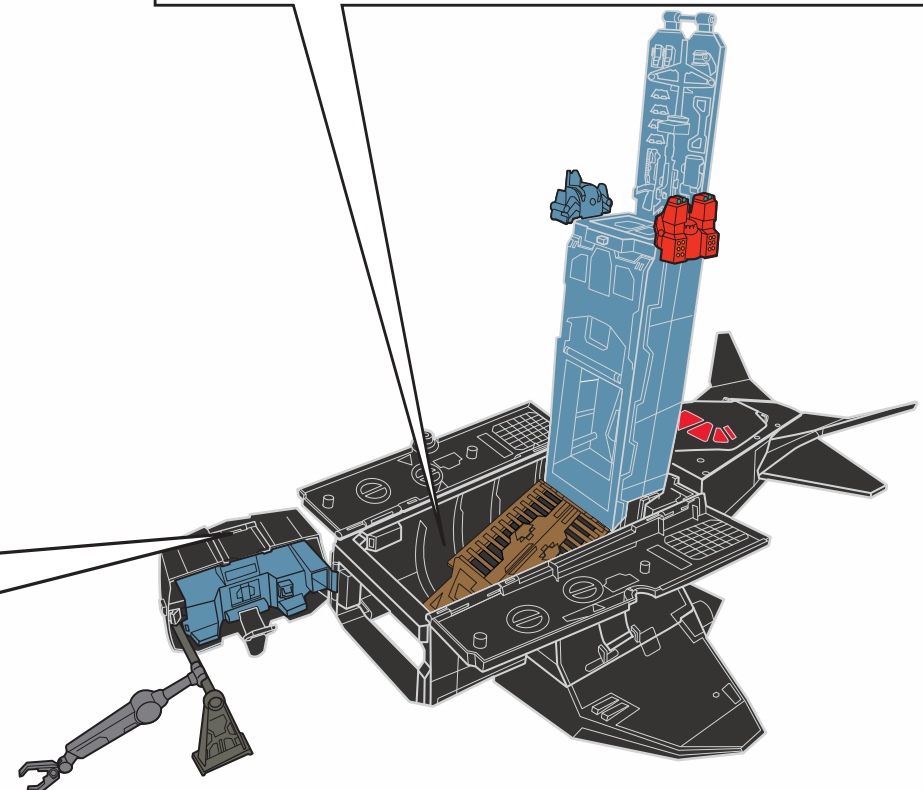
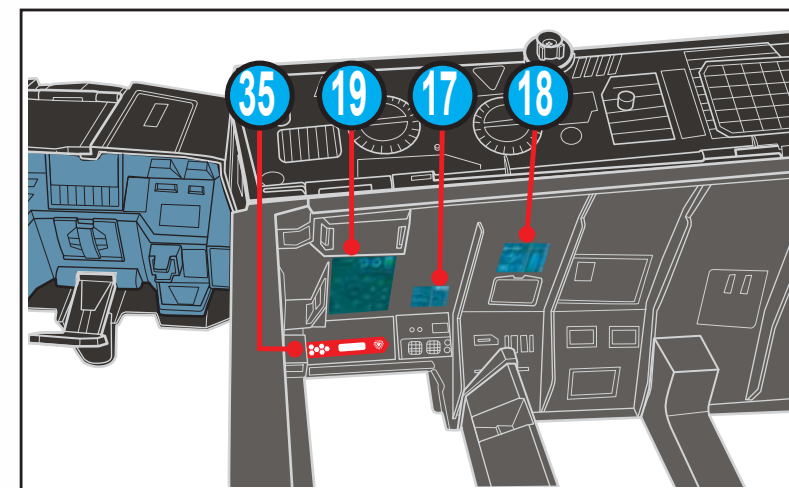
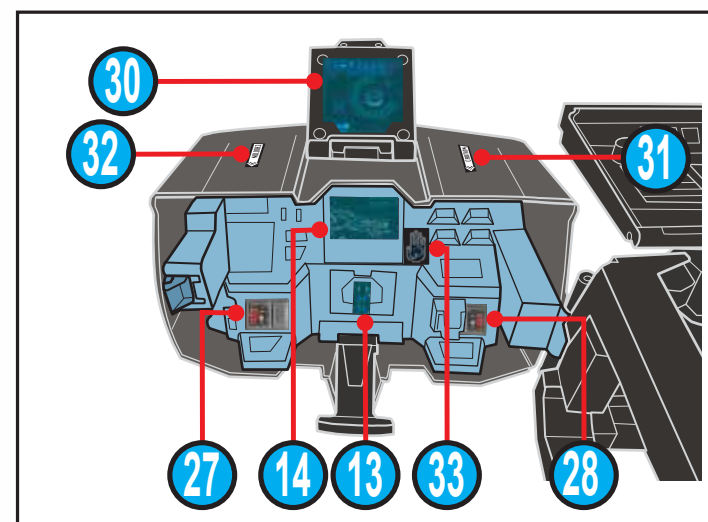
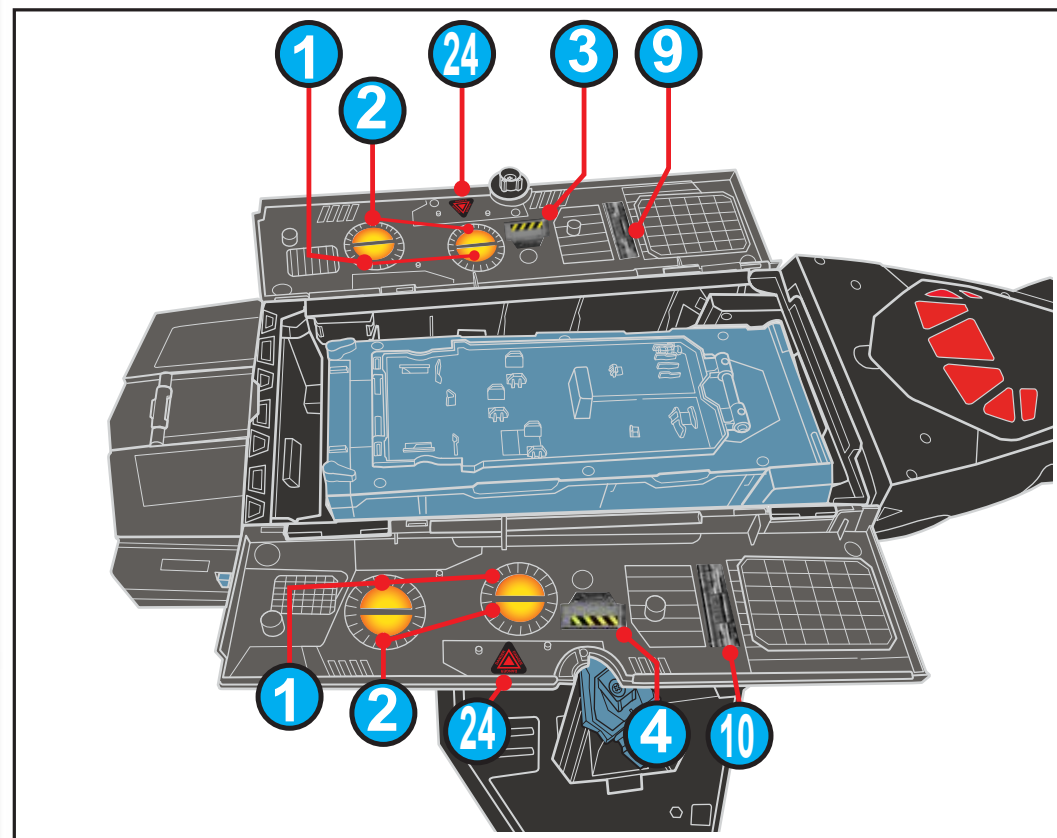

PLAYSET MODE • MODALIDAD DE ESCENARIO • MODE COFFRET DE JEU

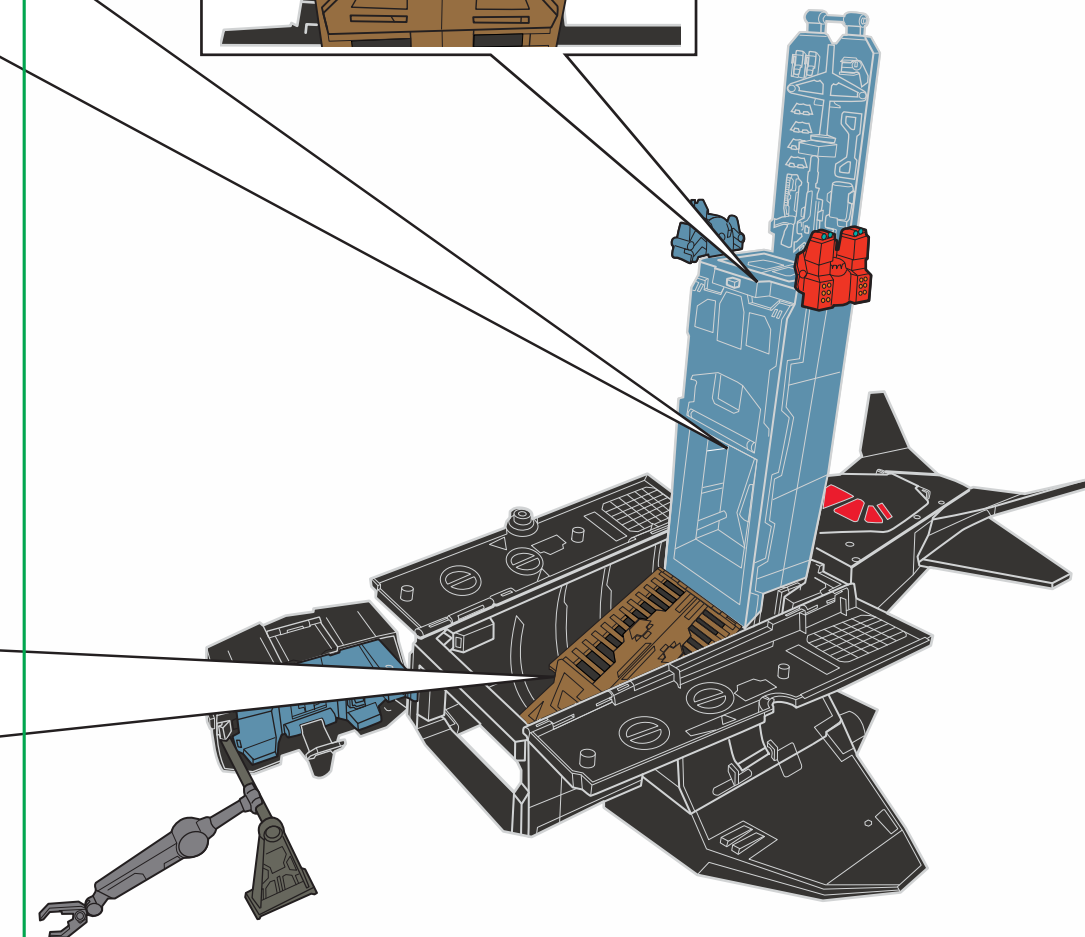
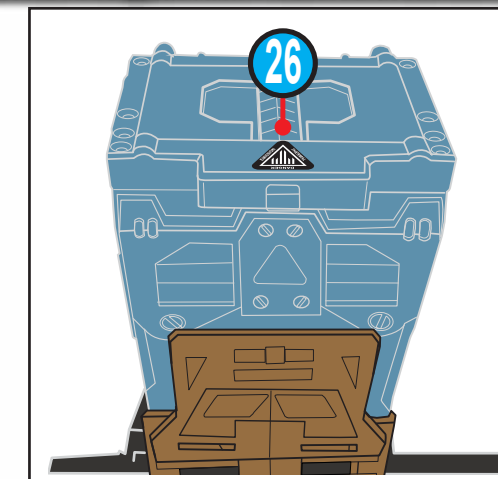
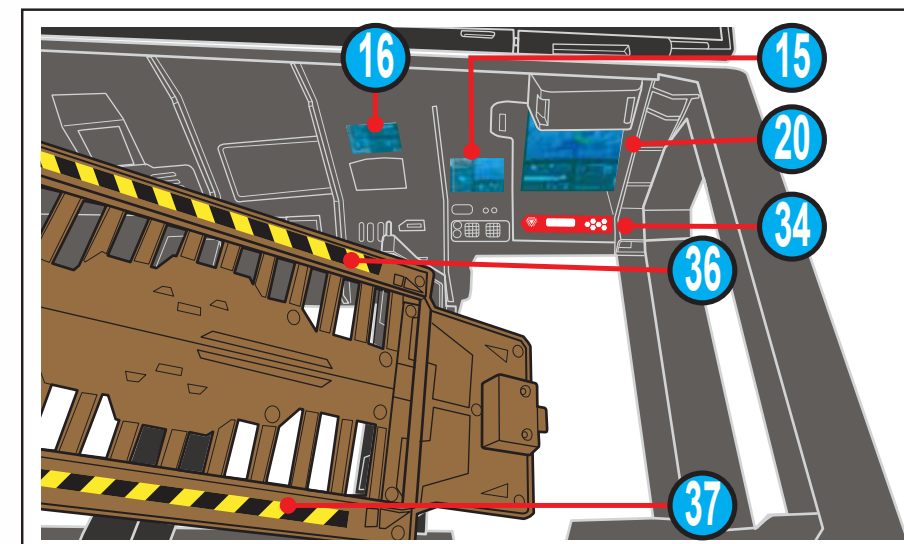
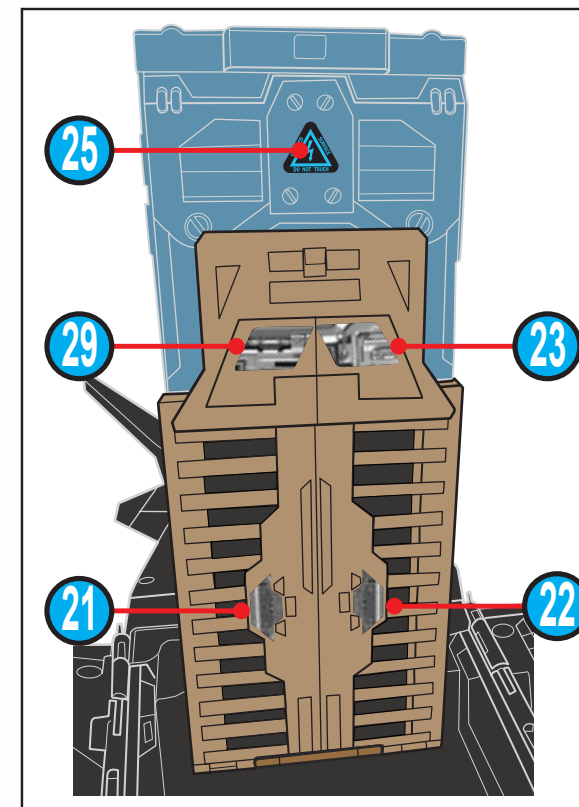

COCKPIT • CABINA • CABINE

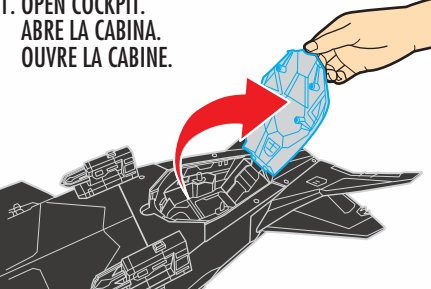
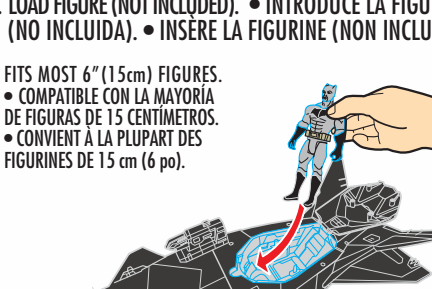
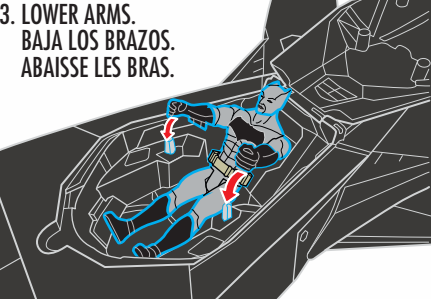
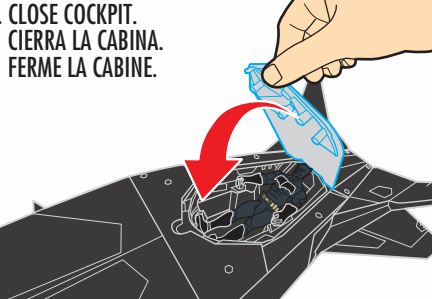
<p>1. OPEN COCKPIT. ABRE LA CABINA. OUVRE LA CABINE.</p> 	<p>2. LOAD FIGURE (NOT INCLUDED). • INTRODUCE LA FIGURA (NO INCLUIDA). • INSÈRE LA FIGURINE (NON INCLUSE).</p> <p>FITS MOST 6" (15cm) FIGURES. • COMPATIBLE CON LA MAYORÍA DE FIGURAS DE 15 CENTÍMETROS. • CONVIENT A LA PLUPART DES FIGURINES DE 15 cm (6 po).</p> 
<p>3. LOWER ARMS. BAJA LOS BRAZOS. ABASSE LES BRAS.</p> 	<p>4. CLOSE COCKPIT. CIERRA LA CABINA. FERME LA CABINE.</p> 

BATMAN™ SOLD SEPARATELY, SUBJECT TO AVAILABILITY.
BATMAN SE VENDE POR SEPARADO Y ESTÁ SUJETO A DISPONIBILIDAD.
BATMAN VENDU SÉPARÉMENT, SELON LA DISPONIBILITÉ.

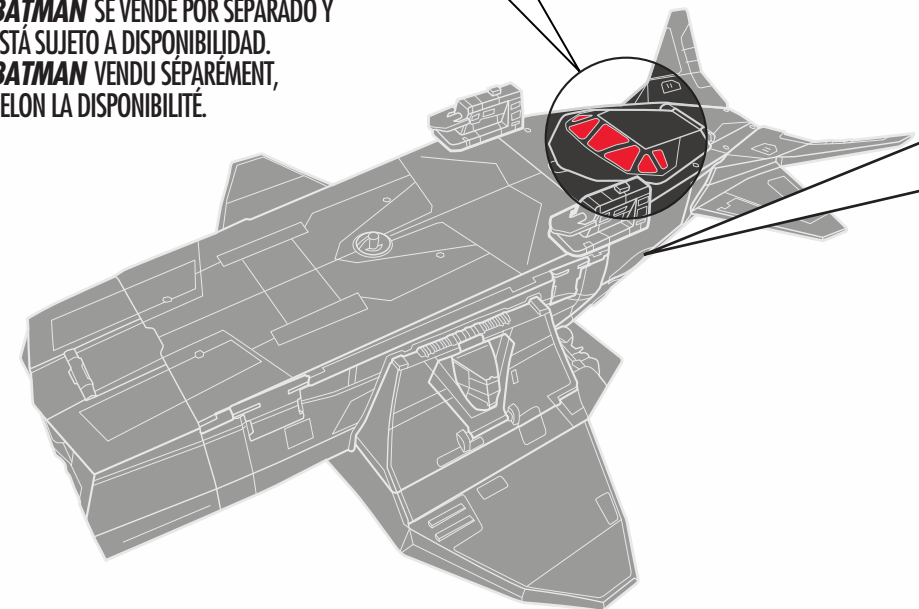

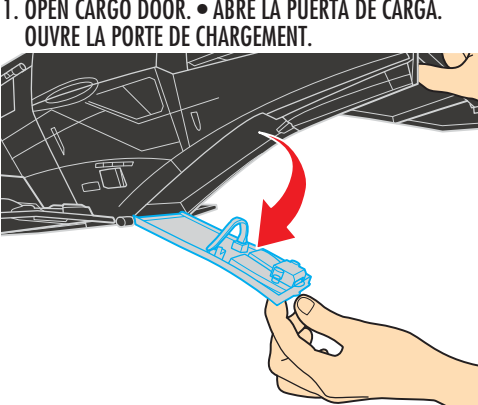
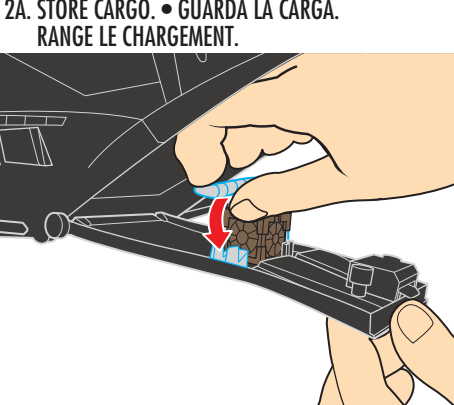
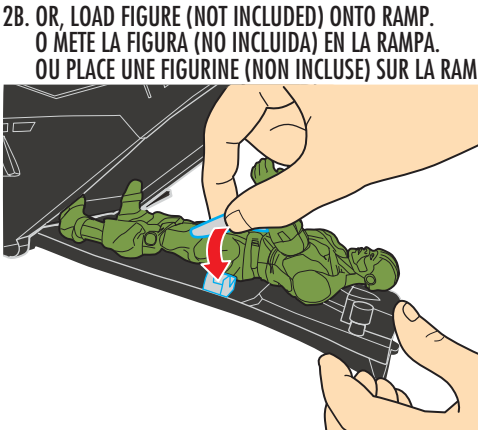
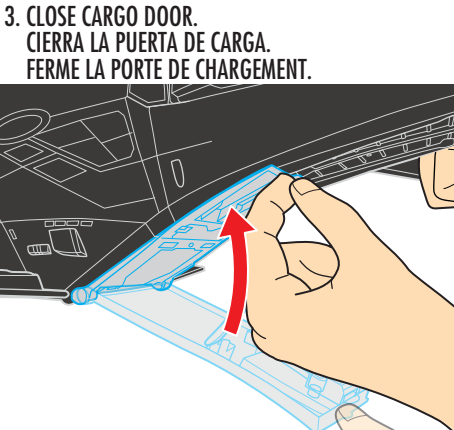

**CARGO & DEPLOYMENT RAMP
 RAMPA DE CARGA Y DESPLIEGUE
 RAMPE DE CHARGEMENT ET DE DÉPLOIEMENT**

<p>1. OPEN CARGO DOOR. • ABRE LA PUERTA DE CARGA. OUVRE LA PORTE DE CHARGEMENT.</p> 	<p>2A. STORE CARGO. • GUARDA LA CARGA. RANGE LE CHARGEMENT.</p> 
<p>2B. OR, LOAD FIGURE (NOT INCLUDED) ONTO RAMP. O METE LA FIGURA (NO INCLUIDA) EN LA RAMPA. OU PLACE UNE FIGURINE (NON INCLUSE) SUR LA RAMPE.</p> 	<p>3. CLOSE CARGO DOOR. CIERRA LA PUERTA DE CARGA. FERME LA PORTE DE CHARGEMENT.</p> 

CYBORG™ SOLD SEPARATELY, SUBJECT TO AVAILABILITY.
CYBORG SE VENDE POR SEPARADO Y ESTÁ SUJETO A DISPONIBILIDAD.
CYBORG VENDU SÉPARÉMENT, SELON LA DISPONIBILITÉ.

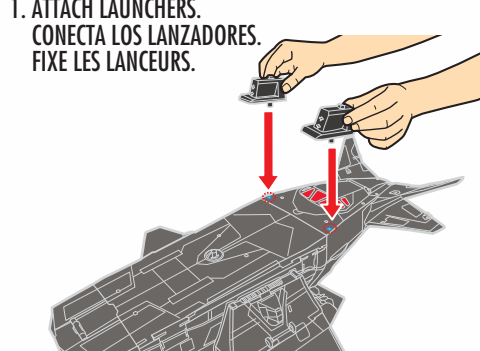
LAUNCHERS • LANZADORES • LANCEURS

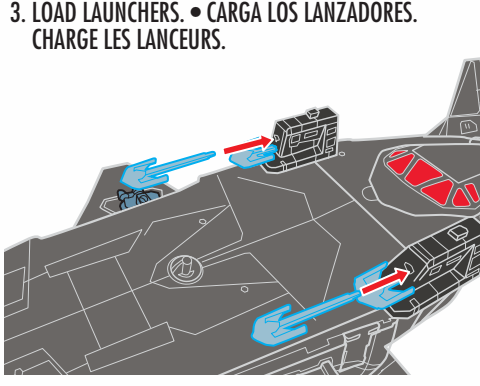
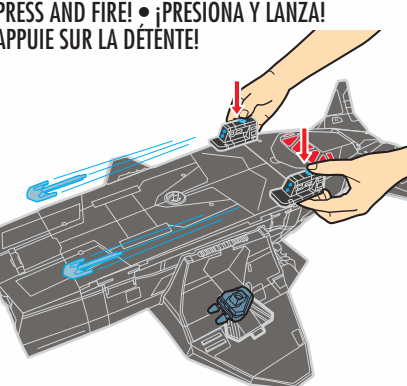
<p>1. ATTACH LAUNCHERS. CONECTA LOS LANZADORES. FIXE LES LANCEURS.</p> 	<p>2. LAUNCHERS CAN BE ATTACHED ANYWHERE YOU SEE THIS TYPE OF SLOT. • PUEDES CONECTAR LOS LANZADORES EN ESTE TIPO DE RANURA. • LES LANCEURS PEUVENT ÊTRE FIXÉS PARTOUT OÙ SE TROUVE CE TYPE DE FIXATION.</p> 
<p>3. LOAD LAUNCHERS. • CARGA LOS LANZADORES. CHARGE LES LANCEURS.</p> 	<p>4. PRESS AND FIRE! • ¡PRESIONA Y LANZA! APPUIE SUR LA DÉTENTE!</p> 

WARNING: DO NOT AIM AT EYES OR FACE. ONLY USE PROJECTILES SUPPLIED WITH THIS TOY. DO NOT FIRE AT POINT BLANK RANGE.

ADVERTENCIA: SI ADQUIRIÓ UN MODELO CON PROYECTIL(ES) INCLUIDO(S): UTILIZAR ÚNICAMENTE EL(LOS) PROYECTIL(ES) INCLUIDO(S) EN ESTE JUGUETE. NO APUNTAR A LOS OJOS NI A LA CARA. NO DISPARAR A PERSONAS NI ANIMALES. NO DISPARAR A QUEMARROPA.

ATTENTION : NE PAS VISER LES YEUX OU LE VISAGE. N'UTILISER QUE LES PROJECTILES FOURNIS AVEC CE JOUET. NE PAS TIRER À BOUT PORTANT.

HIDDEN CANNONS • CAÑONES OCULTOS • CANONS SECRETS

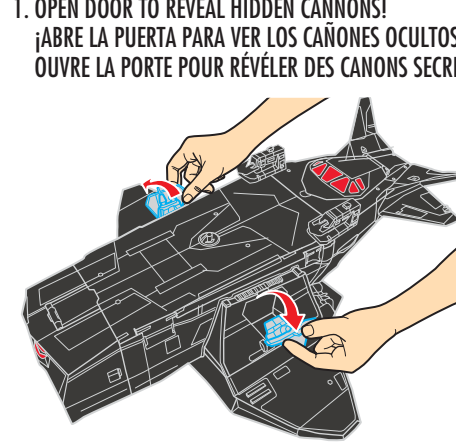
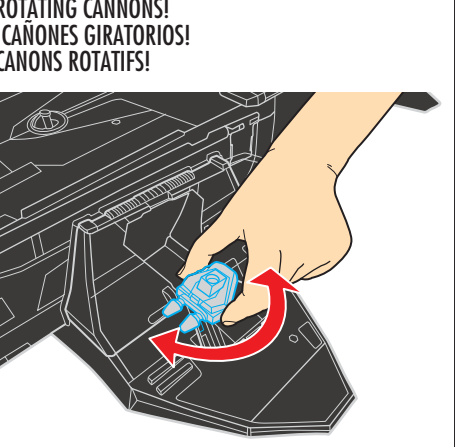
<p>1. OPEN DOOR TO REVEAL HIDDEN CANNONS! ¡ABRE LA PUERTA PARA VER LOS CAÑONES OCULTOS! OUVRE LA PORTE POUR RÉVÉLER DES CANONS SECRETS!</p> 	<p>2. ROTATING CANNONS! ¡CAÑONES GIRATORIOS! CANONS ROTATIFS!</p> 
---	---

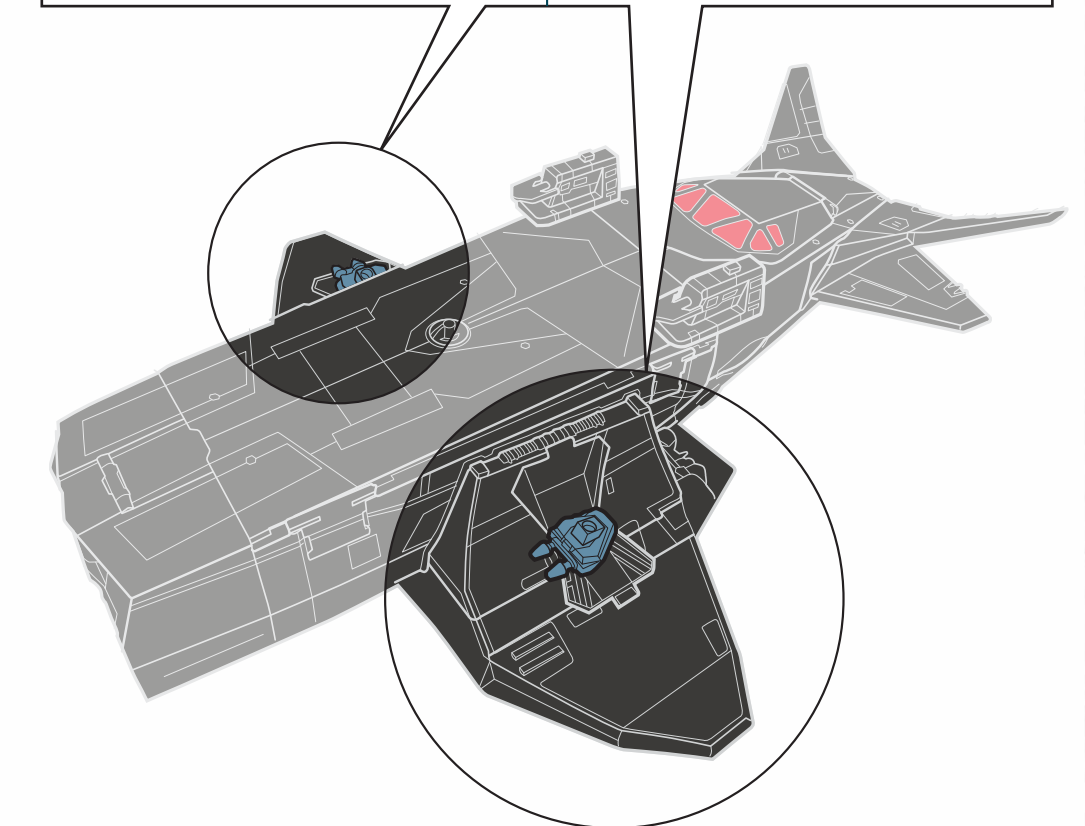

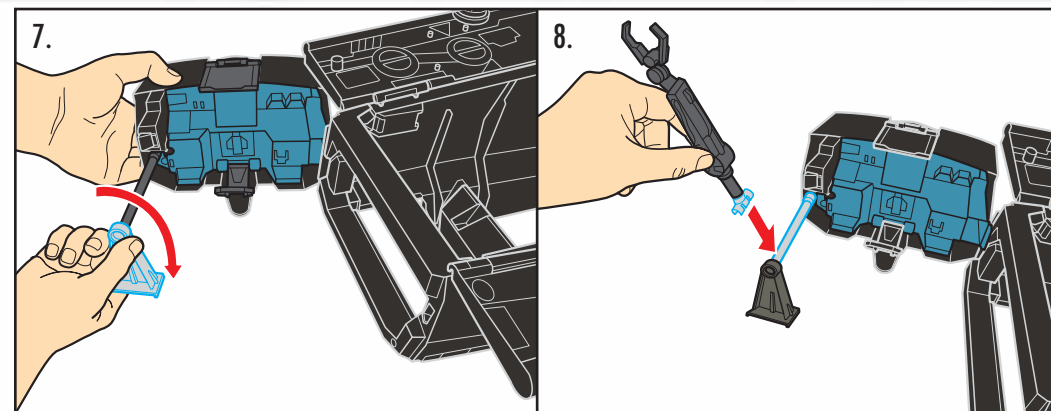
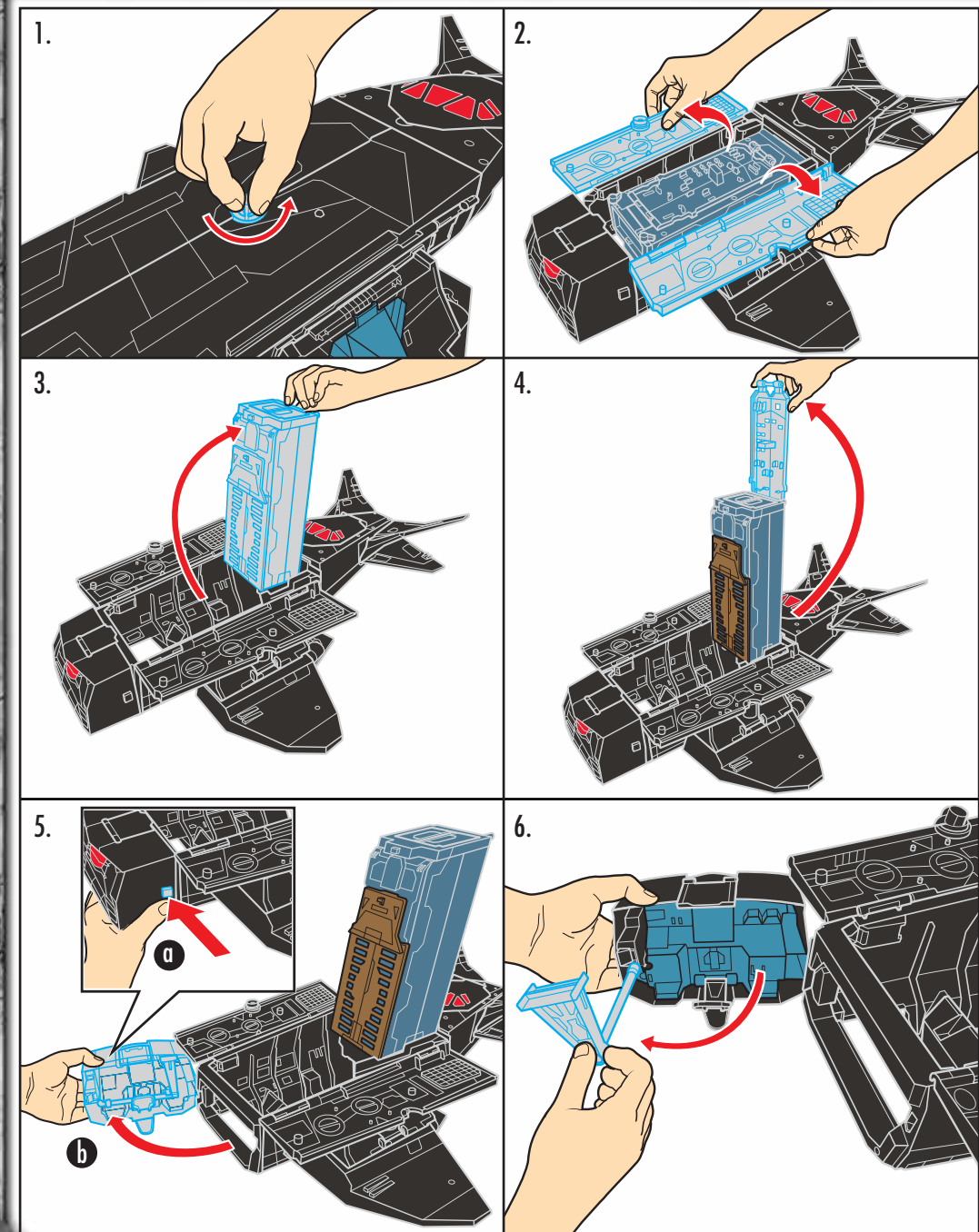

REVERSE ORDER OF INSTRUCTION STEPS TO TRANSFORM BACK INTO VEHICLE.
 INVIERTE EL ORDEN DE LOS PASOS PARA CONVERTIRLO DE VUELTA EN VEHÍCULO.
 INVERSE L'ORDRE DES ÉTAPES POUR LE RETRANSFORMER EN VÉHICULE.

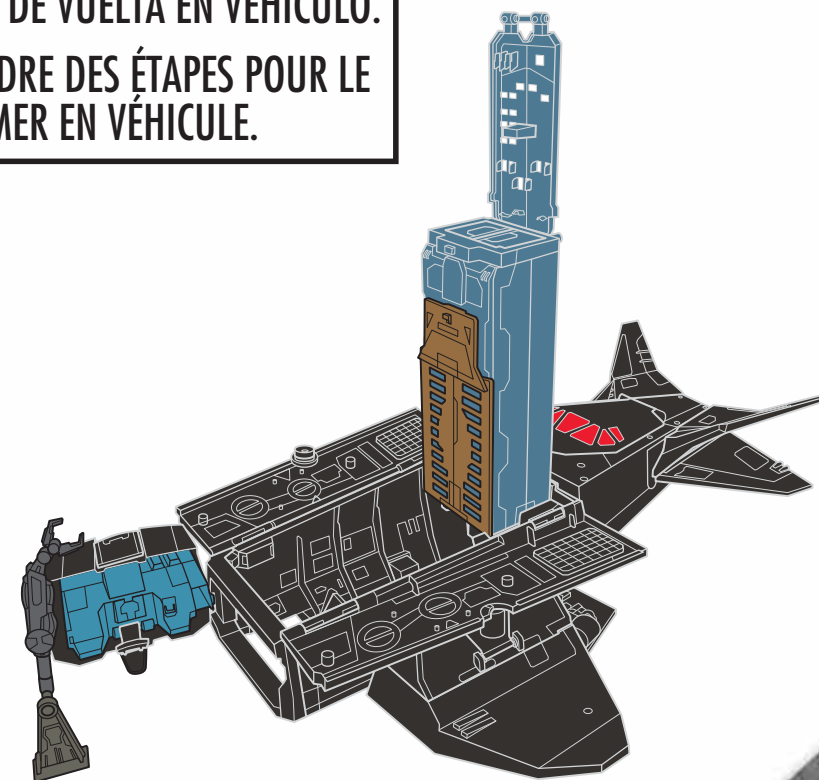

ZIPLINE • TIROLESA • TYROLIENNE

1. ATTACH ZIPLINE TO HANDLE.
 CONECTA LA TIROLESA AL ASA.
 FIXE LA TYROLIENNE À LA POIGNÉE.

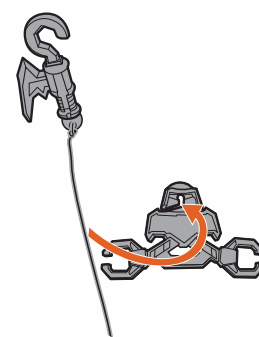

2. HOOK ONE END OF THE ZIPLINE TO THE TOP OF THE WEAPONRY.
 ENGANCH A UN EXTREMO DE LA TIROLESA A LA PARTE DE ARRIBA DE LA ESTACIÓN DE ARMAS.
 FIXE UNE EXTRÉMITÉ DE LA TYROLIENNE AU SOMMET DE L'ARMEMENT.

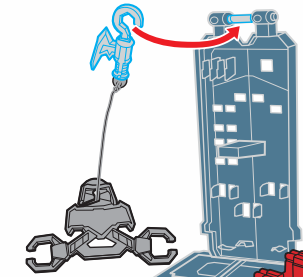

3. WRAP ZIPLINE AROUND OTHER END OF THE HOOK TO ADJUST LENGTH.
 ENROLLA LA TIROLESA ALREDEDOR DEL OTRO EXTREMO DEL GANCHO PARA AJUSTAR LA LONGITUD.
 ENROULE LA TYROLIENNE AUTOUR DE L'AUTRE EXTRÉMITÉ DU CROCHET POUR EN AJUSTER LA LONGUEUR.

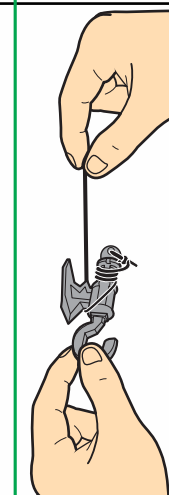

4. HOOK THE OTHER END TO THE DIAGNOSTIC CENTER.
 ENGANCH A EL OTRO EXTREMO AL CENTRO DE DIAGNÓSTICO.
 FIXE L'AUTRE EXTRÉMITÉ AU CENTRE DE DIAGNOSTIC.

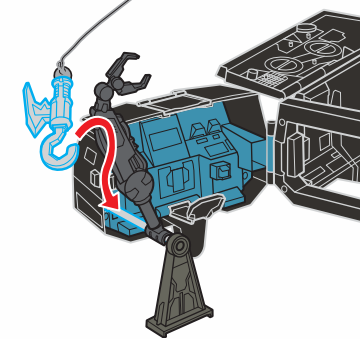

5. ATTACH FIGURE TO ZIPLINE.
 CONECTA LA FIGURA A LA TIROLESA.
 FIXE LA FIGURINE À LA TYROLIENNE.

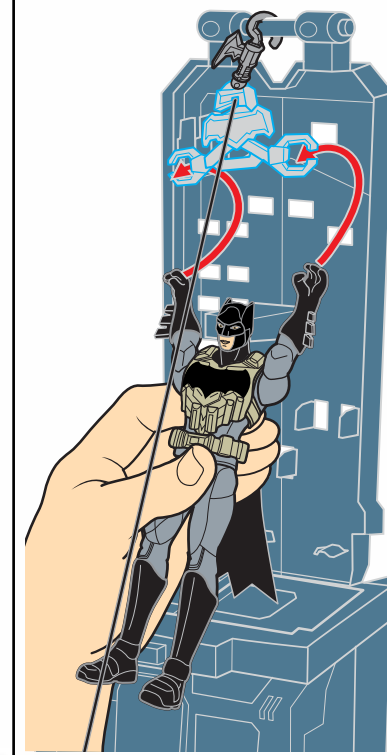

6. RACE DOWN THE ZIPLINE!
 ¡BAJA POR LA TIROLESA!
 DESCENDS LA TYROLIENNE!

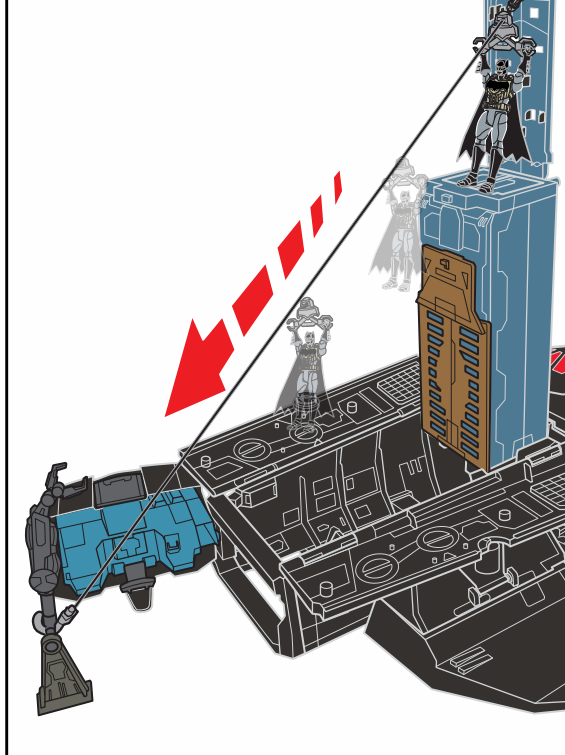

BATMAN™ SOLD SEPARATELY, SUBJECT TO AVAILABILITY.
BATMAN SE VENDE POR SEPARADO Y ESTÁ SUJETO A DISPONIBILIDAD.
BATMAN VENDU SÉPARÉMENT, SELON LA DISPONIBILITÉ.

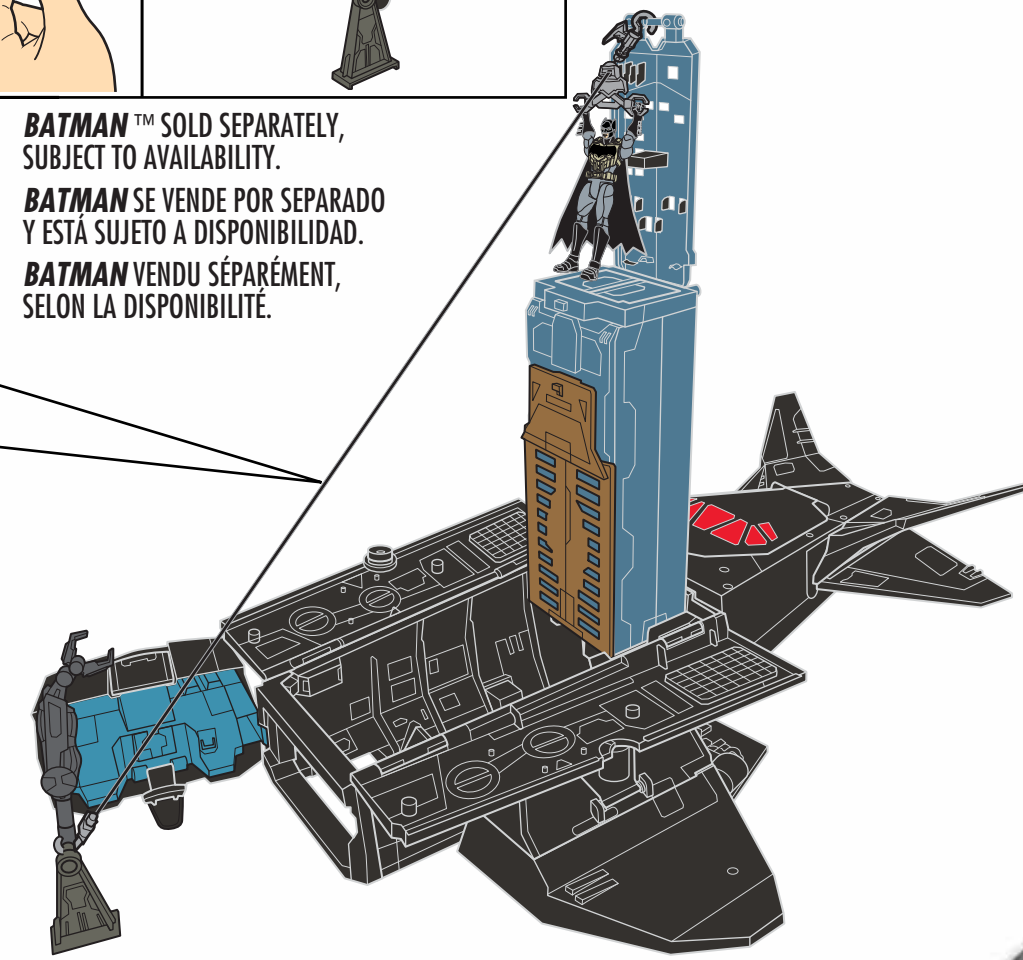

TRAP & EJECTION DOOR • TRAMPILLA Y PUERTAS DE SALIDA • TRAPPE ET PORTE D'ÉJECTION

1. PLACE FIGURE IN FRONT OF THE WEAPONRY.
PON LA FIGURA ENFRETE DE LA ESTACIÓN DE ARMAS.
PLACE LA FIGURINE DEVANT L'ARMEMENT.

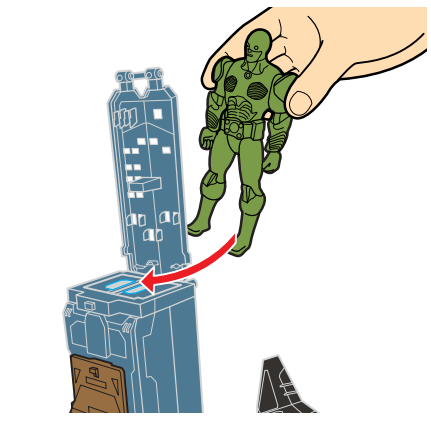

2. PUSH BUTTON TO TRAP FIGURE.
PRESIONA EL BOTÓN PARA ATRAPAR LA FIGURA.
APPUIE SUR LE BOUTON POUR PIÉGER LA FIGURINE.

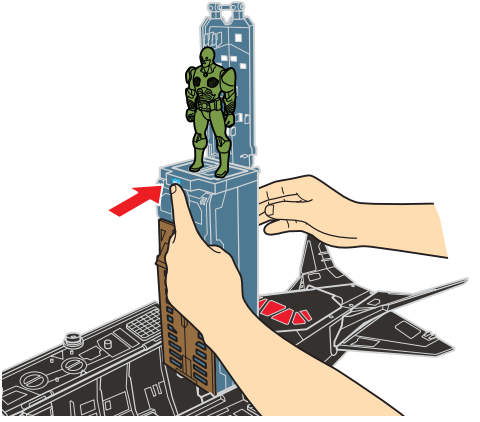

3. PRESS SWITCH AND OPEN EJECTION DOOR TO RELEASE FIGURE.
PRESIONA EL SWITCH Y ABRE LA PUERTA DE SALIDA PARA LIBERAR LA FIGURA.
APPUIE SUR LE BOUTON ET OUVRE LA PORTE D'ÉJECTION POUR LIBÉRER LA FIGURE.

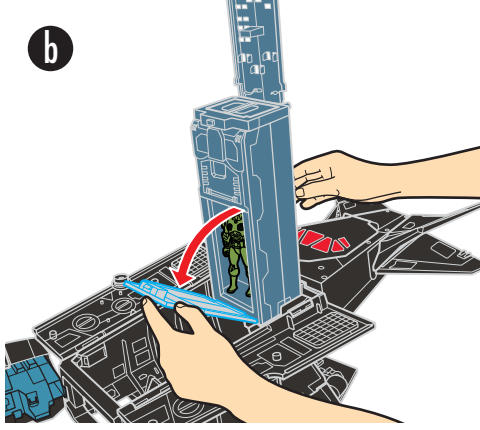
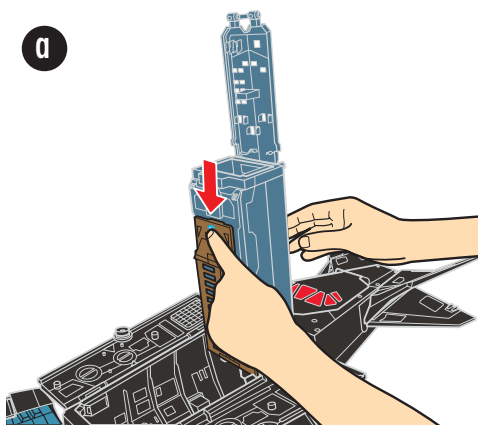

PARADEMON™ SOLD SEPARATELY, SUBJECT TO AVAILABILITY.
PARADEMON SE VENDE POR SEPARADO Y ESTÁ SUJETO A DISPONIBILIDAD.
PARADEMON VENDU SÉPARÉMENT, SELON LA DISPONIBILITÉ.

TO RESET • PARA RESTABLECER • POUR RÉENCLANCHER

1.

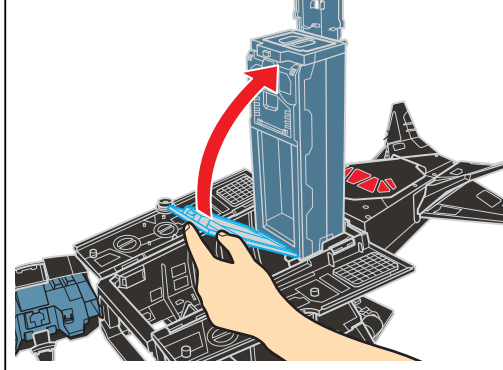

2.

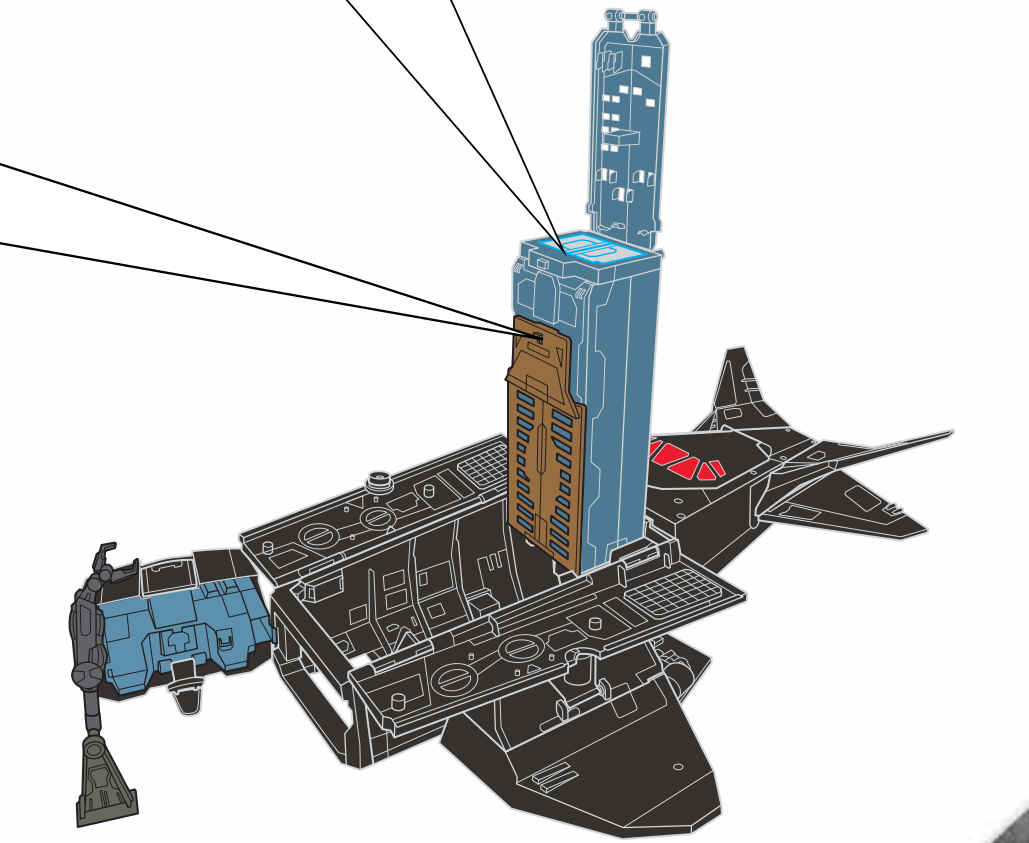
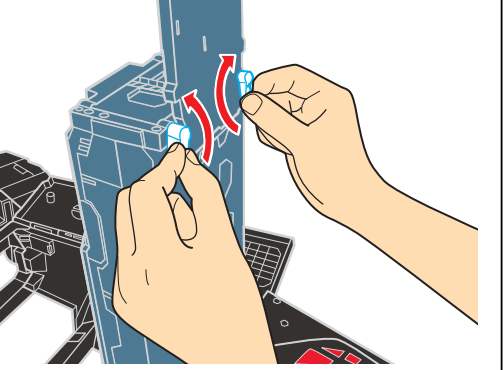

WEAPONRY STATION • ESTACIÓN DE ARMAS • STATION D'ARMEMENT

STORE WEAPONS ON THE WEAPONRY STATION.
GUARDA LAS ARMAS EN LA ESTACIÓN DE ARMAS.
RANGE DES ARMES DANS LA STATION D'ARMEMENT.

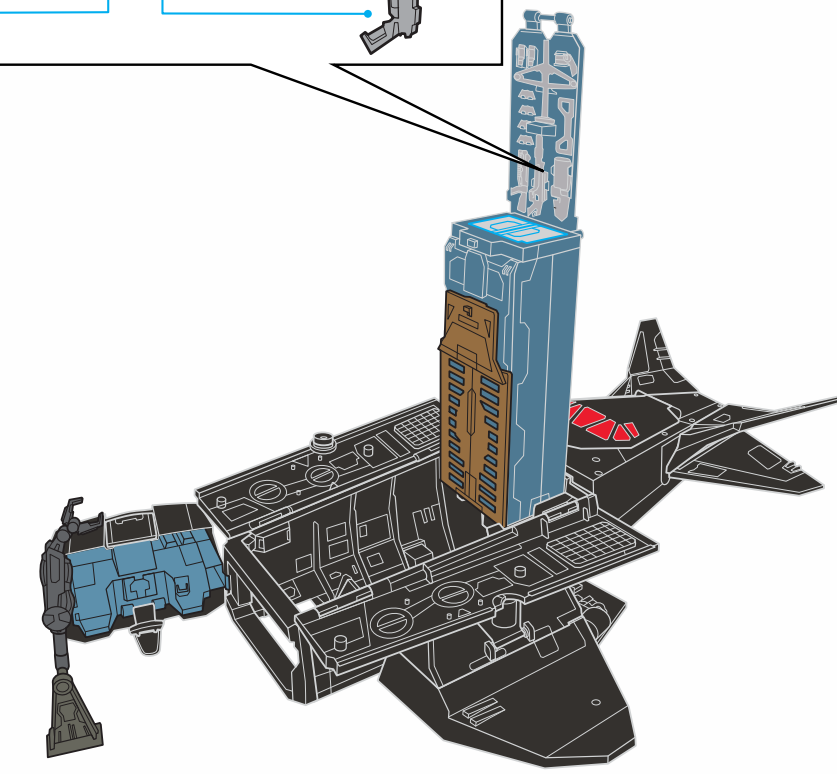
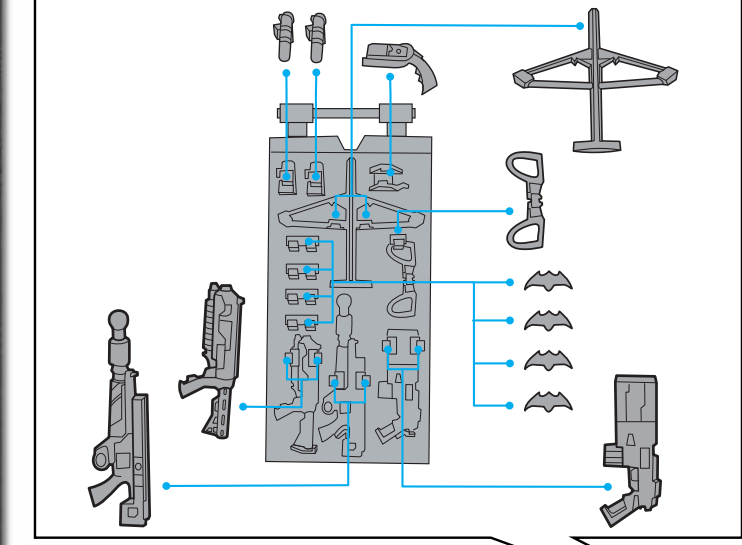

ARMORS • ARMADURAS • ARMURES

1. STORE ARMORS ON THE PLAYSET. • GUARDA LA ARMADURA EN EL SET DE JUEGO. • RANGE LES ARMURES DANS LE COFFRET DE JEU.

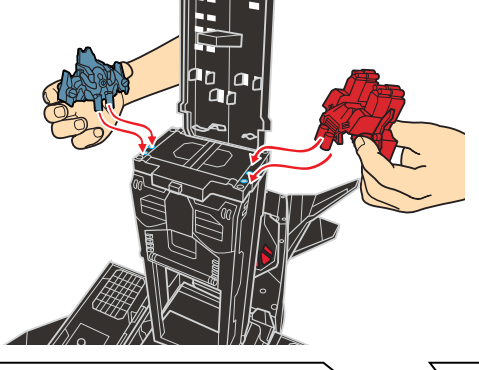

2. ARMOR UP! • ¡PONTE LA ARMADURA! • ENFILE LES ARMURES!

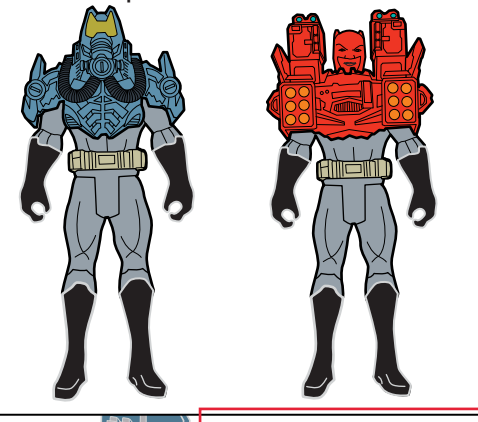

FITS MOST 6" (15cm) FIGURES.
• COMPATIBLE CON LA MAYORÍA DE FIGURAS DE 15 CENTÍMETROS.
• CONVIENT À LA PLUPART DES FIGURINES DE 15 cm (6 po).

BATMAN™ SOLD SEPARATELY, SUBJECT TO AVAILABILITY.
BATMAN SE VENDE POR SEPARADO Y ESTÁ SUJETO A DISPONIBILIDAD.
BATMAN VENDU SÉPARÉMENT, SELON LA DISPONIBILITÉ.

