

INSTRUCTIONS



WARNING:
CHOKING HAZARD - Small parts.
Not for children under 3 years.

5+

service.mattel.com
HOTWHEELS.COM



FGR76-0970
1101669863-DOM

COLORS AND DECORATIONS MAY VARY.

INCLUDES 4 VEHICLES. ADDITIONAL VEHICLES SOLD SEPARATELY.

ADULT ASSEMBLY REQUIRED

REQUIRES 4 "D" SIZE (LR20) ALKALINE BATTERIES (NOT INCLUDED).

DISPOSE OF BATTERIES SAFELY.

PLEASE KEEP THESE INSTRUCTIONS FOR FUTURE REFERENCE AS THEY CONTAIN IMPORTANT INFORMATION.

INDEX

BATTERY INSTALLATION 3

CONTENTS 4

| | | |
|----------|--------|----|
| ASSEMBLY | ZONE 1 | 5 |
| | ZONE 2 | 10 |
| | ZONE 3 | 13 |
| | ZONE 4 | 17 |

TO PLAY 20

MORE WAYS TO PLAY 27

PERFORMANCE TIPS 28

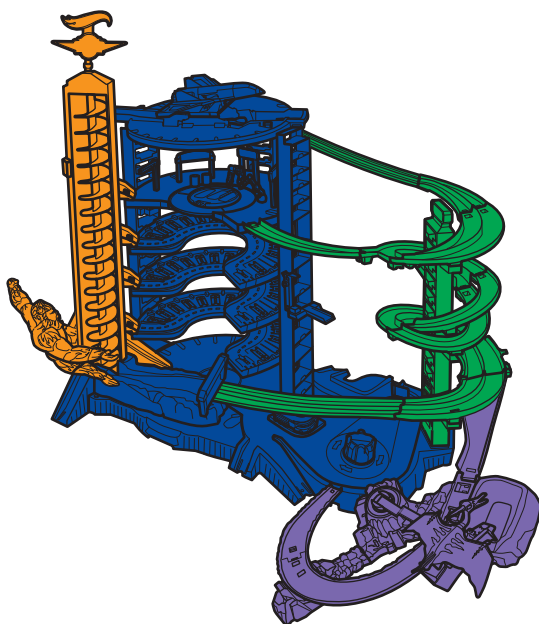

ZONE 2 ZONE 1 ZONE 3 ZONE 4

BATTERY INSTALLATION

- Unscrew the battery cover with a Phillips head screwdriver (not included).
- Install 4 "D" size (LR20) alkaline batteries (not included) in the orientation (+/-) shown.
- Replace battery cover and tighten screws.
- For longer life use alkaline batteries.
- Replace the batteries if elevator can no longer transport vehicles up.
- When exposed to an electrostatic source, the product may malfunction. To resume normal operation, remove and re-install the batteries.

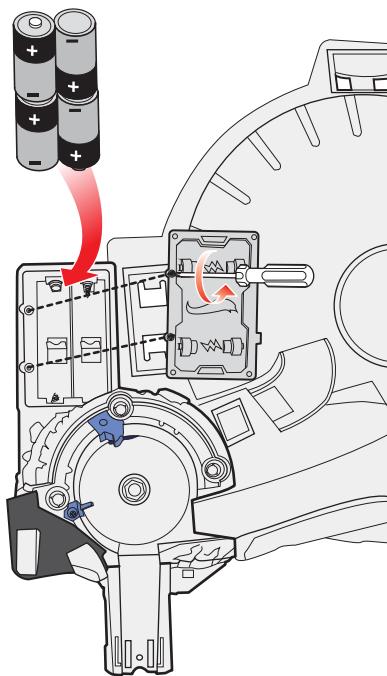

BATTERY SAFETY INFORMATION

In exceptional circumstances batteries may leak fluids that can cause a chemical burn injury or ruin your product. To avoid battery leakage:

- Non-rechargeable batteries are not to be recharged.
- Rechargeable batteries are to be removed from the product before being charged.
- Rechargeable batteries are only to be charged under adult supervision.
- Do not mix alkaline, standard (carbon-zinc), or rechargeable batteries.
- Do not mix old and new batteries.
- Only batteries of the same or equivalent type as recommended are to be used.
- Batteries are to be inserted with the correct polarity.
- Exhausted batteries are to be removed from the product.
- The supply terminals are not to be short-circuited.
- Dispose of battery(ies) safely.
- Do not dispose of this product in a fire. The batteries inside may explode or leak.



Protect the environment by not disposing of this product or any batteries with household waste. This symbol indicates that this product shall not be treated as household waste. Check your local authority for recycling advice and facilities.

CONTENTS

ZONE 1

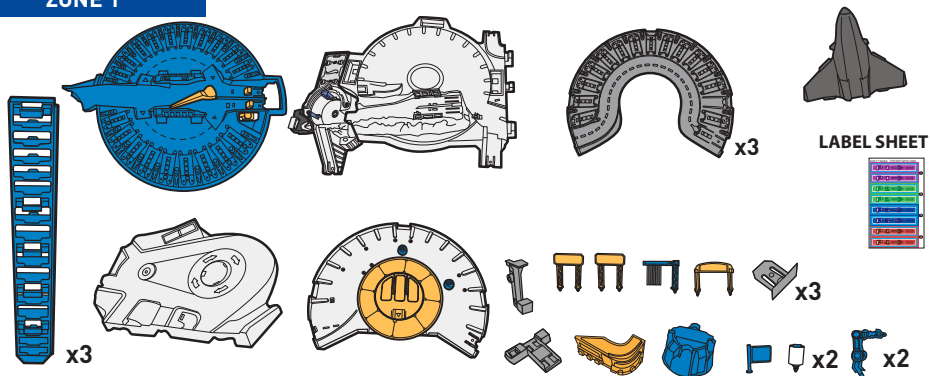

ZONE 2

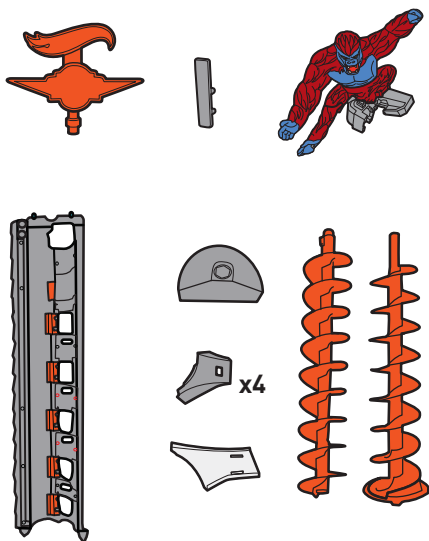

ZONE 3

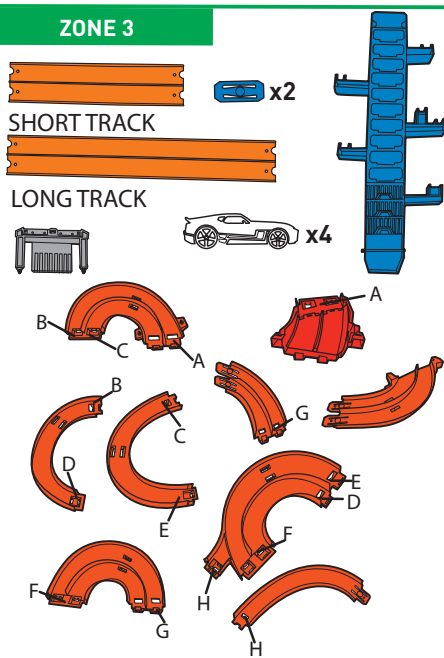

ZONE 4

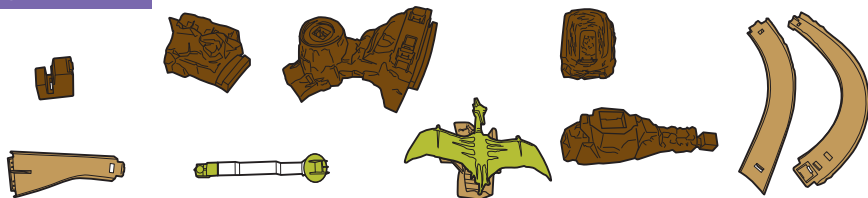

ZONE 1

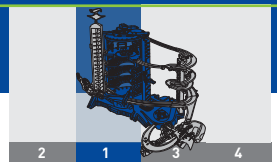

1. **INSTALL BATTERIES FIRST
(PAGE 3)**

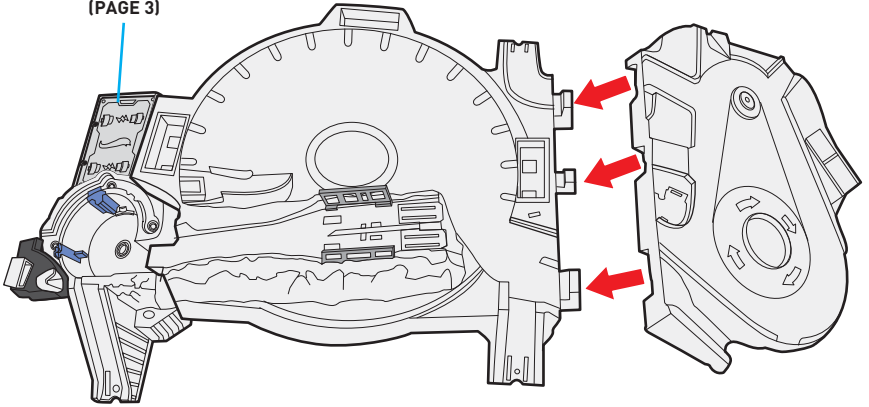

2.

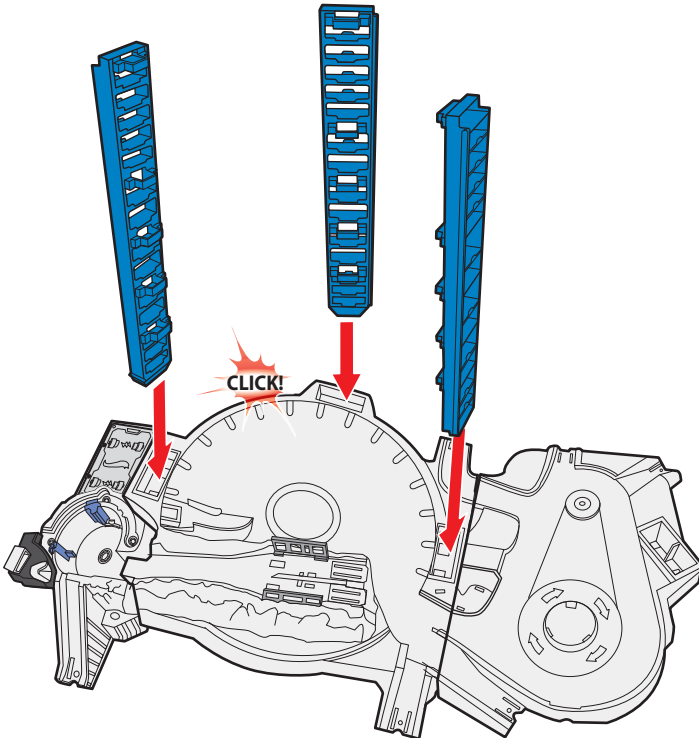

3. ATTACH PLATFORMS FROM THE BOTTOM UP.

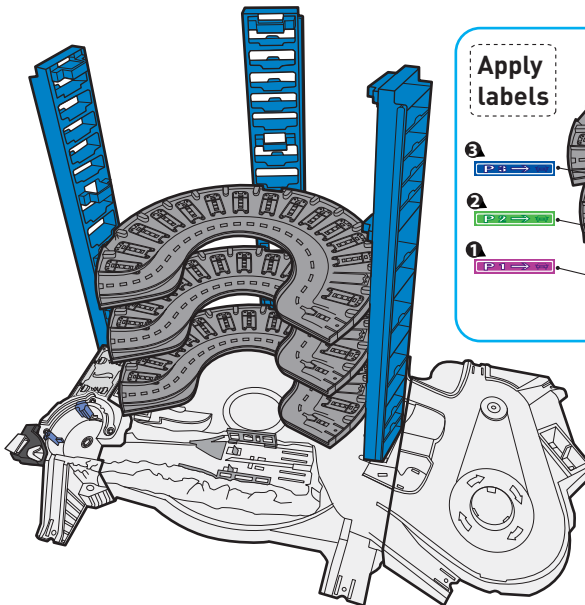
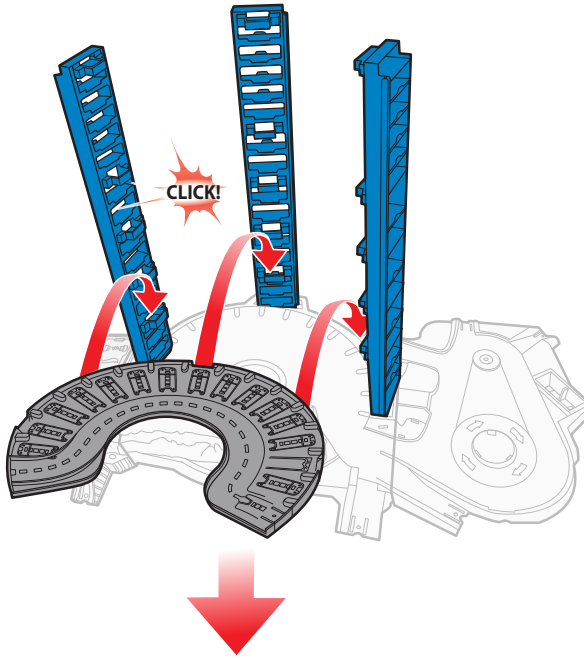

Apply labels

3
2
1

P-1
P-2
P-3

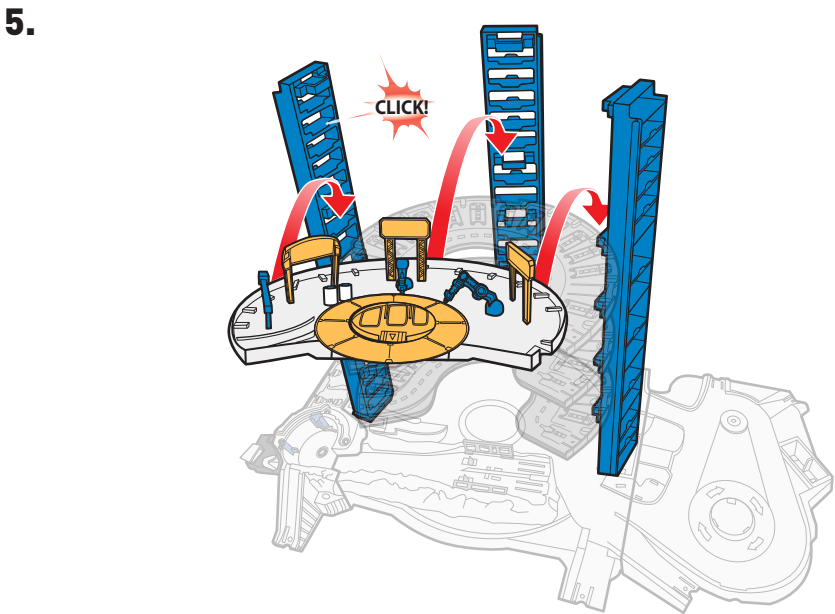
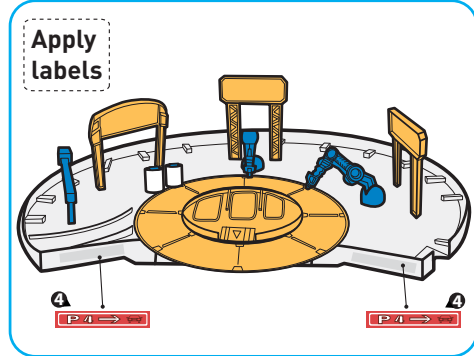
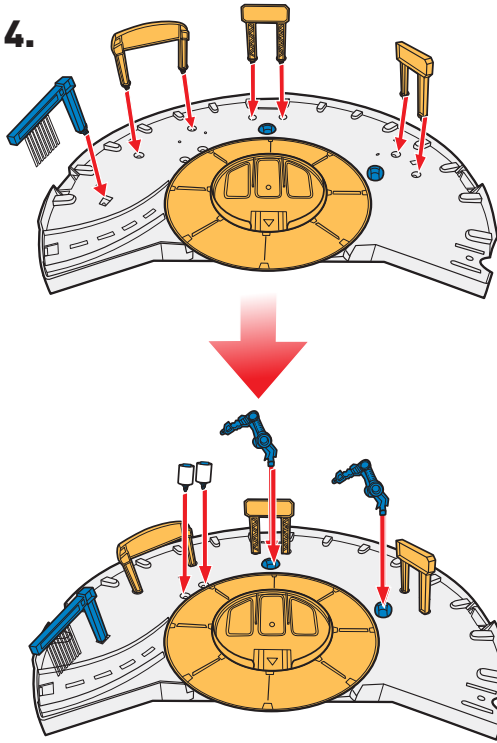

6.

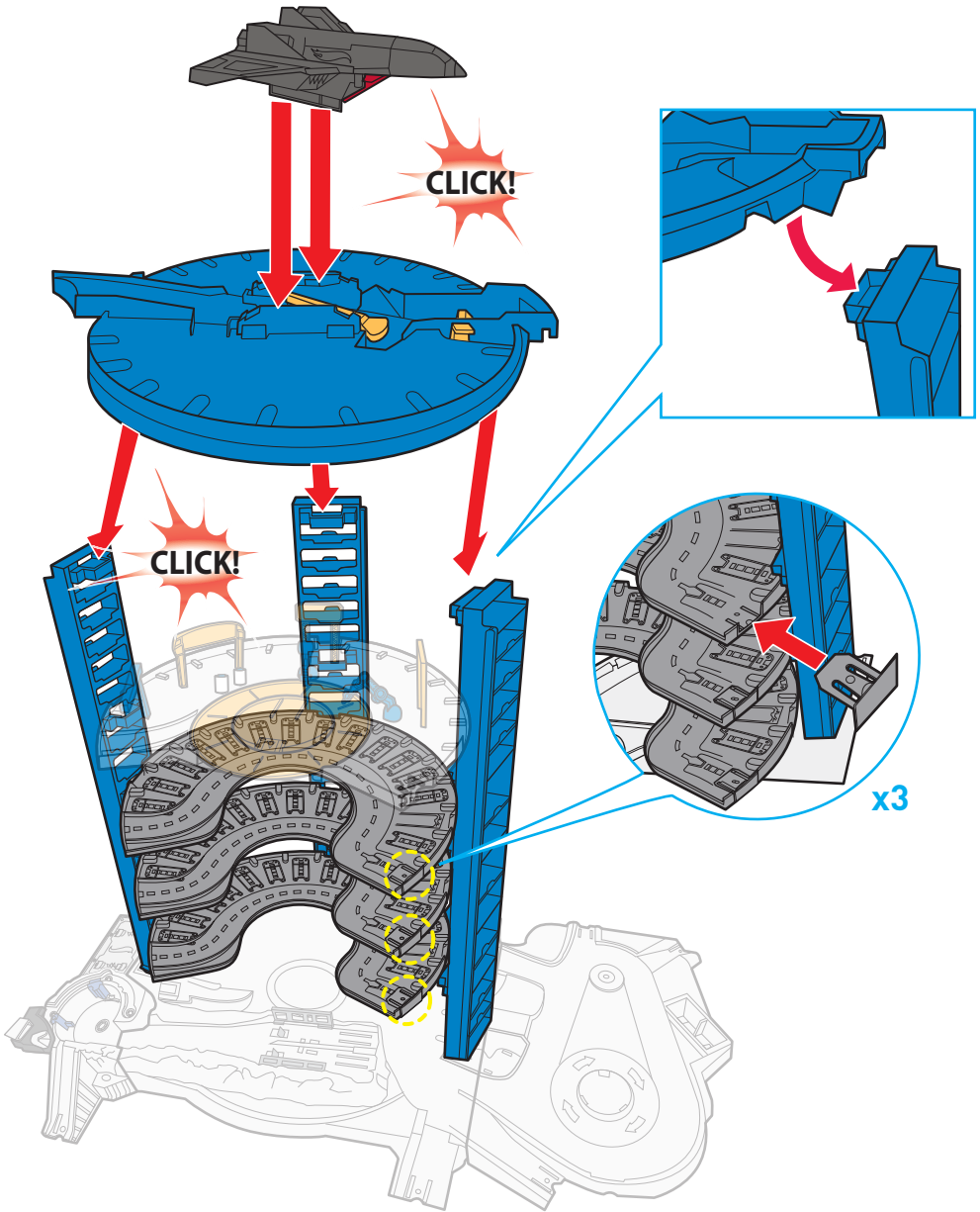

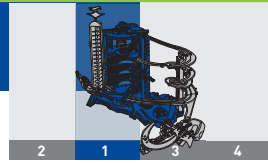

7.

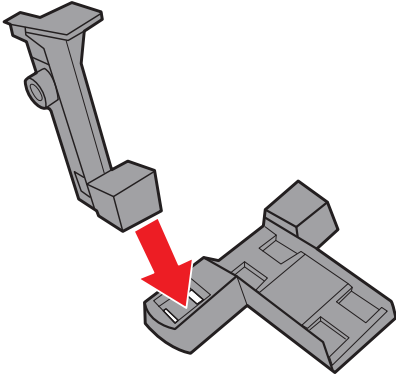

8.

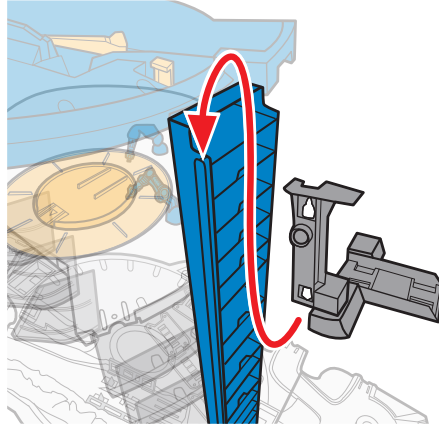

9.

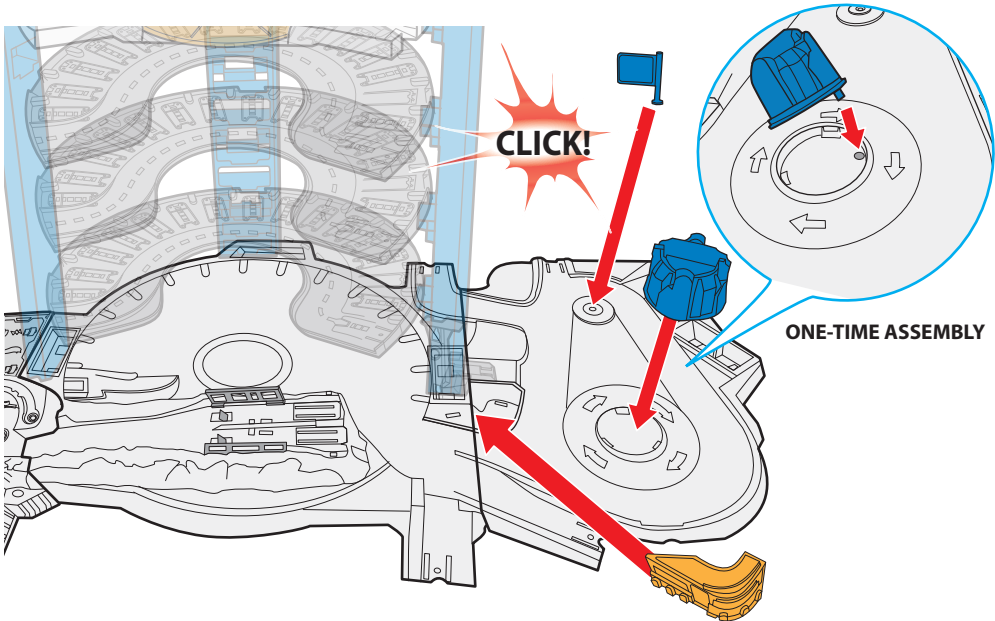

ZONE 2

1.

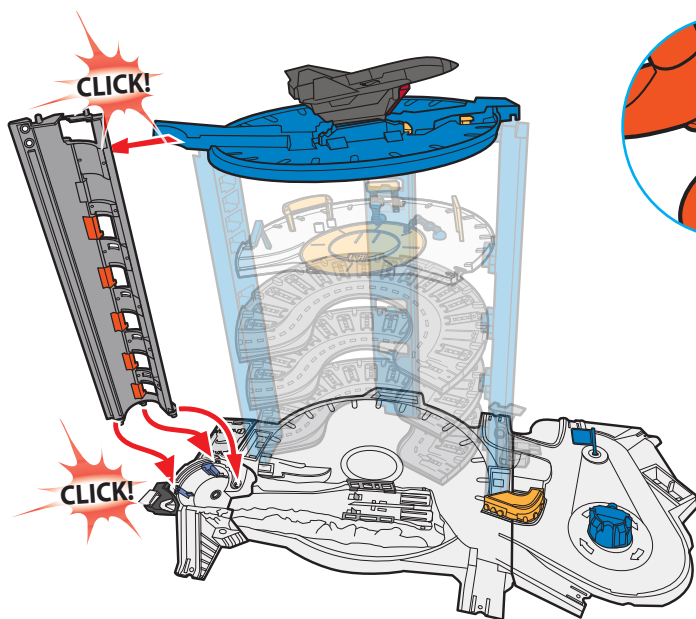

2.

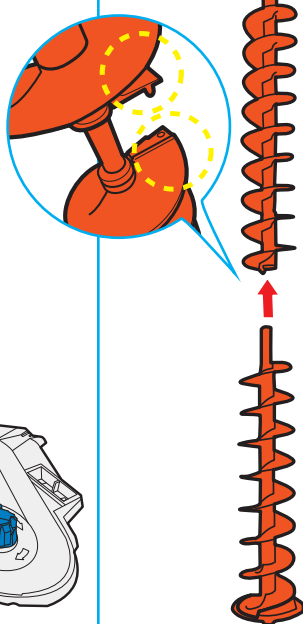

3.

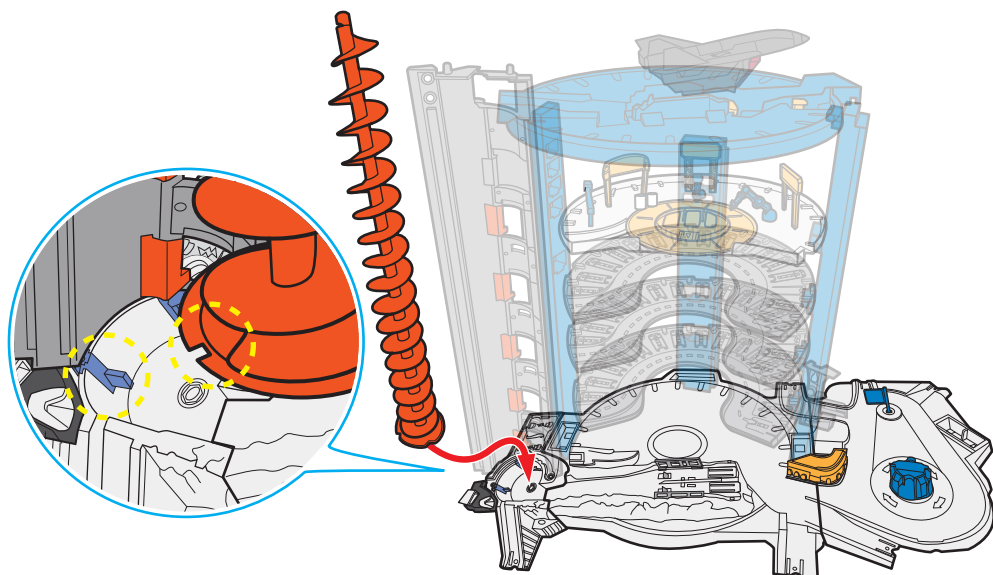

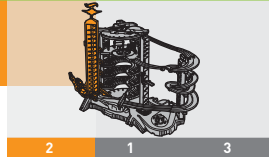

4.

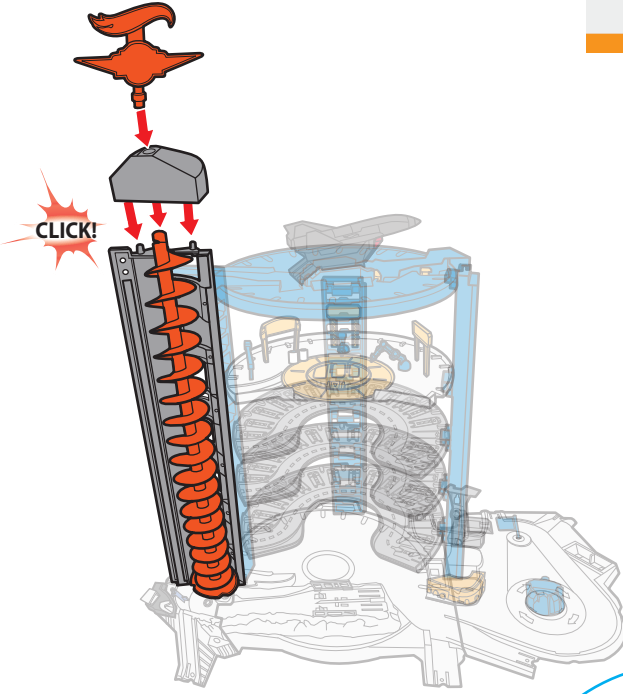

5.

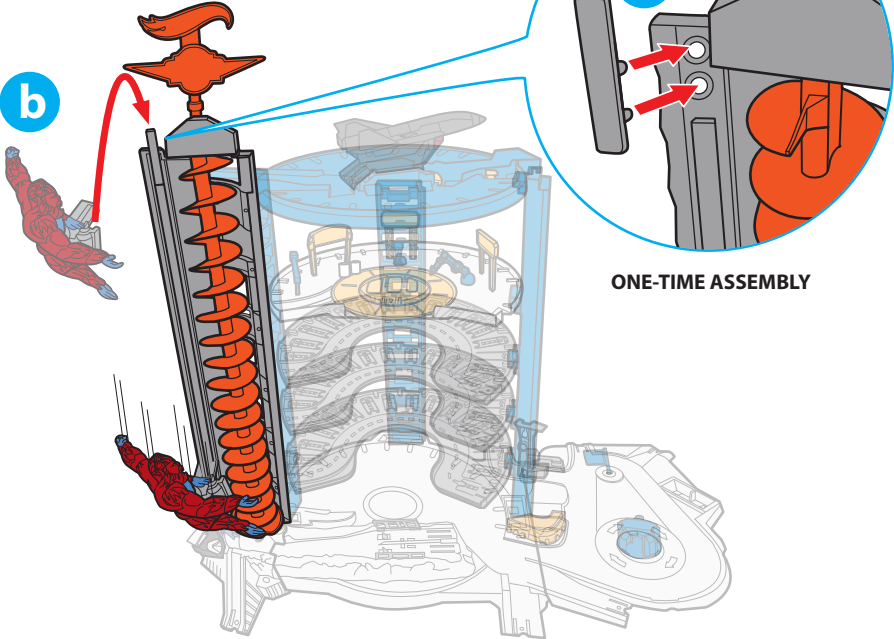

6.

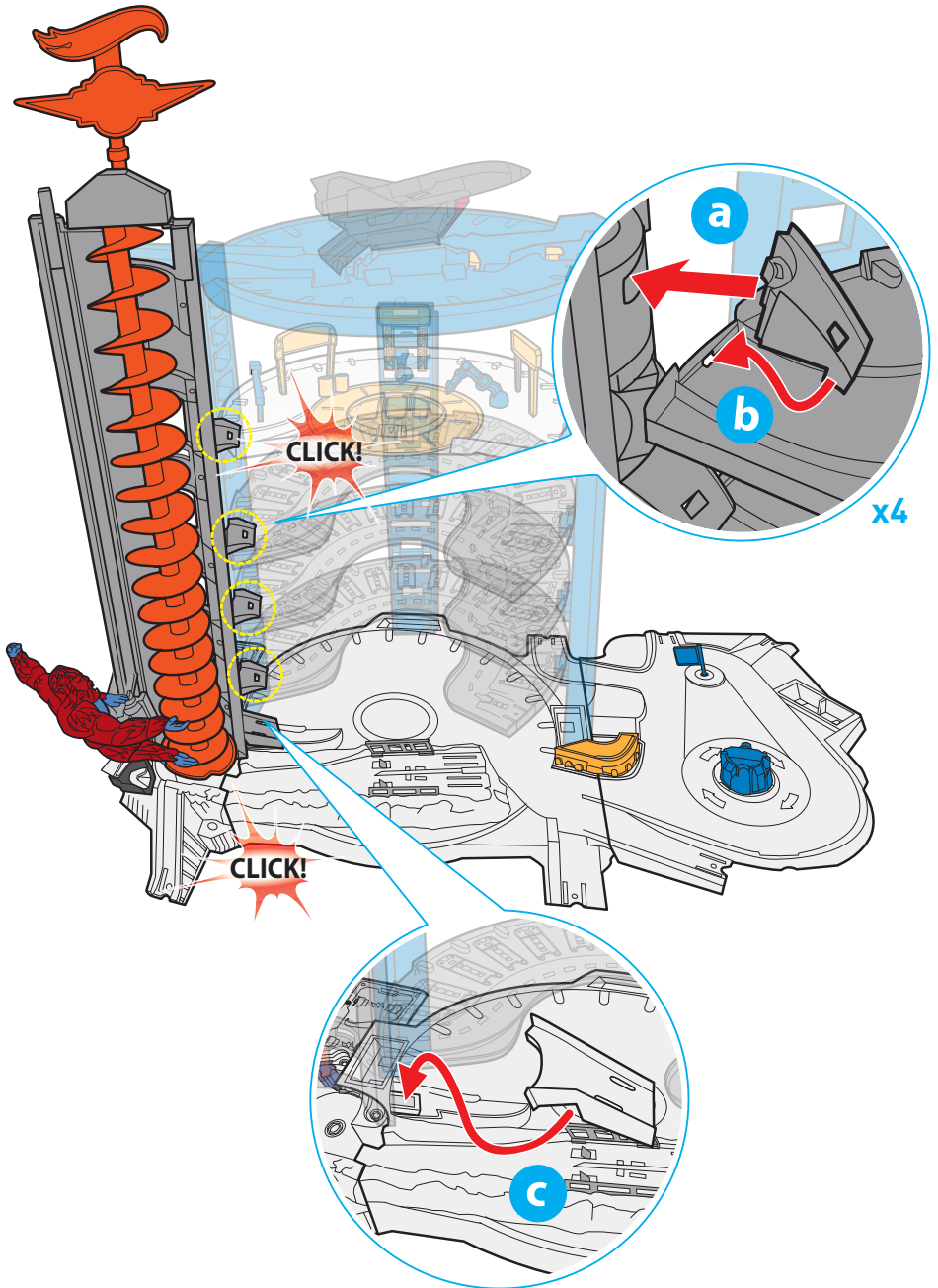

ZONE 3

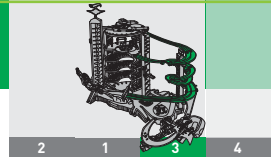

1.

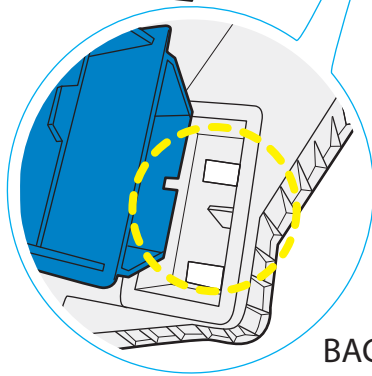
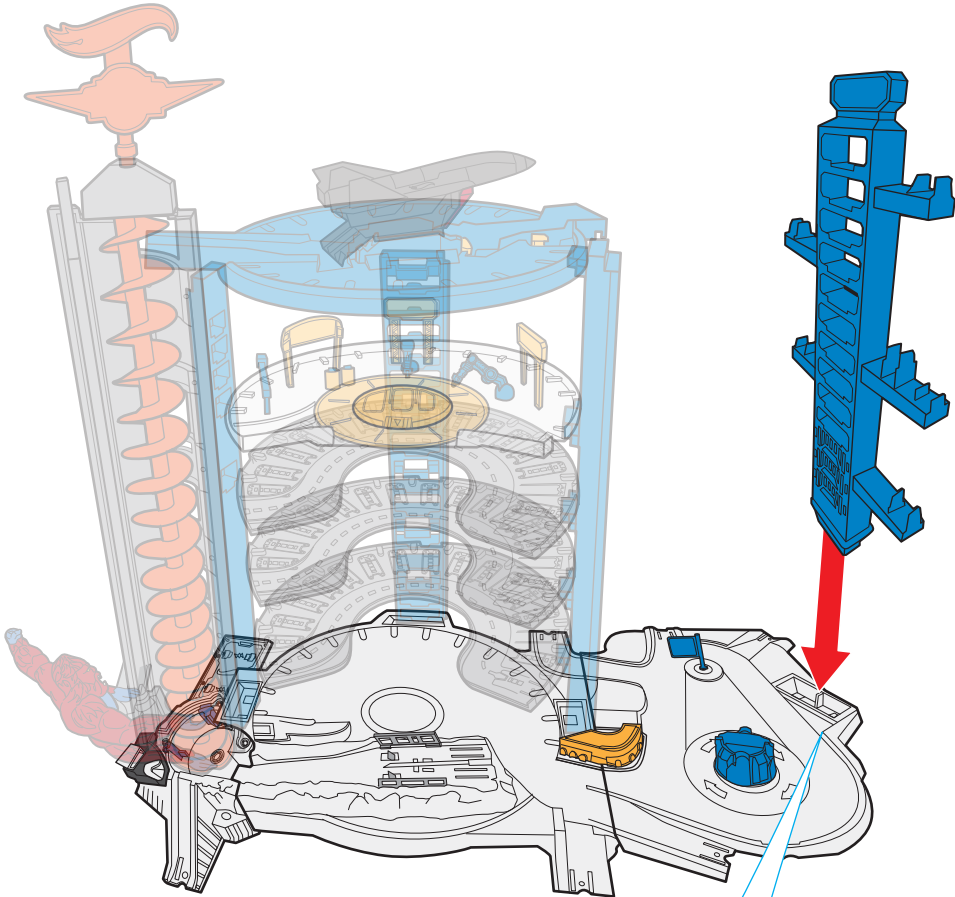

BACK VIEW

ASSEMBLY
ZONE 3

2.

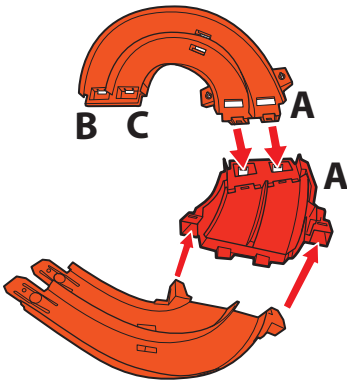

3.

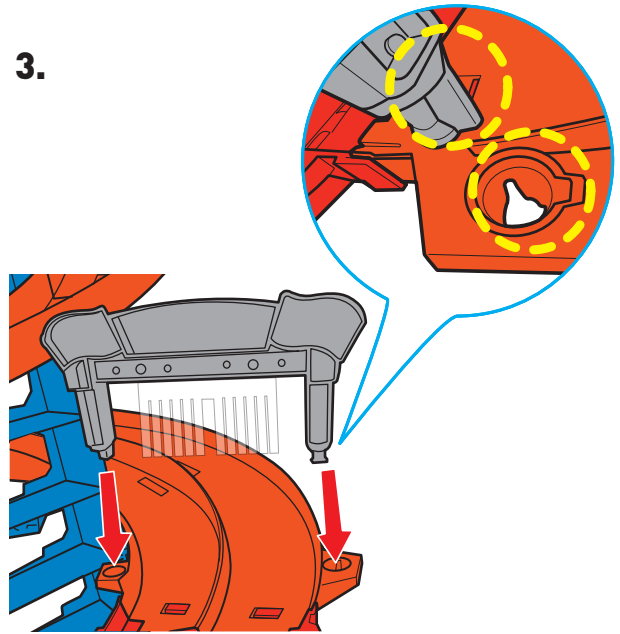

4.

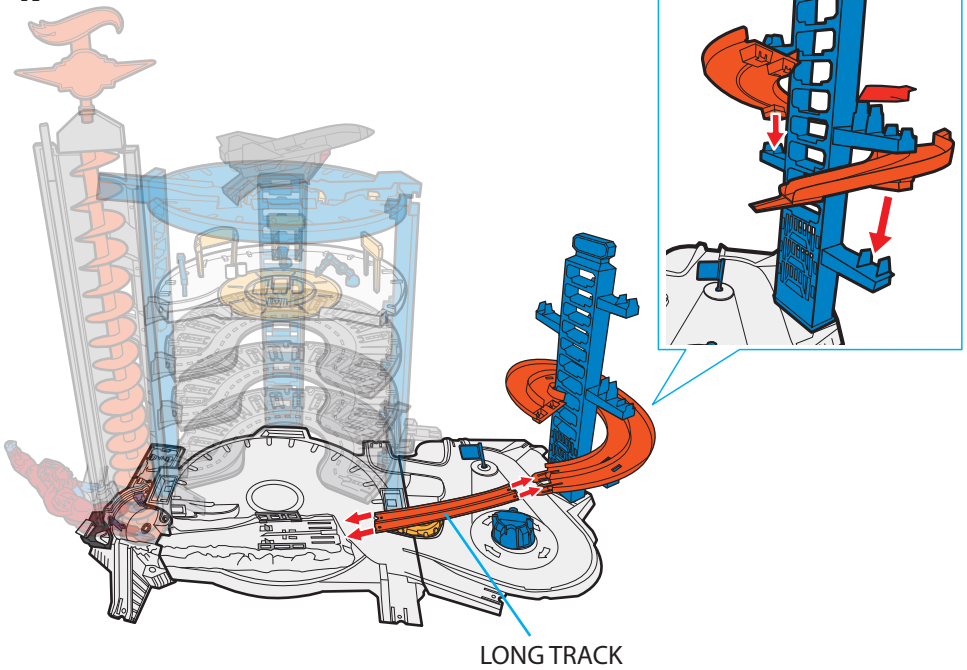



Refer to letters shown for easy assembly.

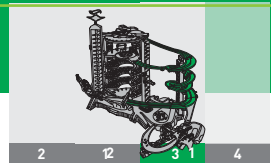

5.

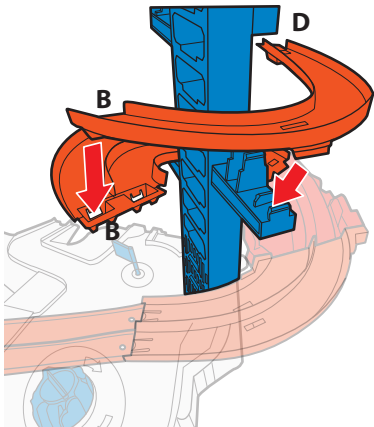

6.

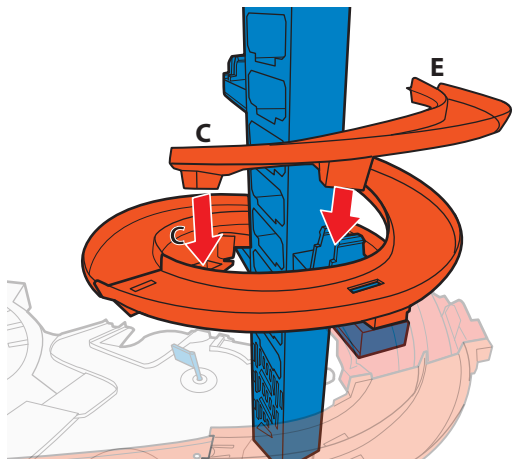

7.

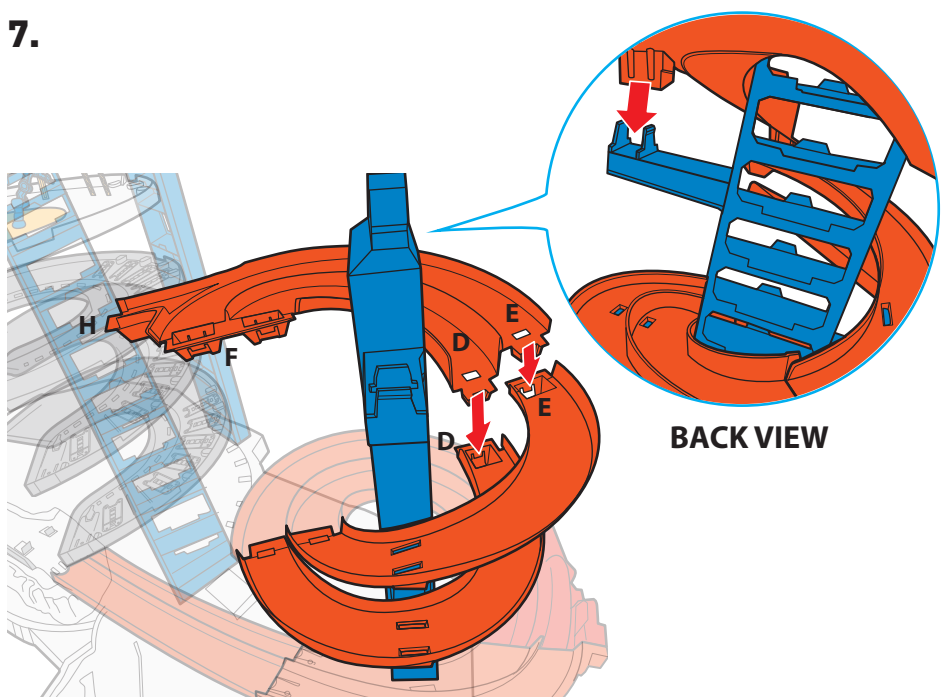

ASSEMBLY
ZONE 3

8.

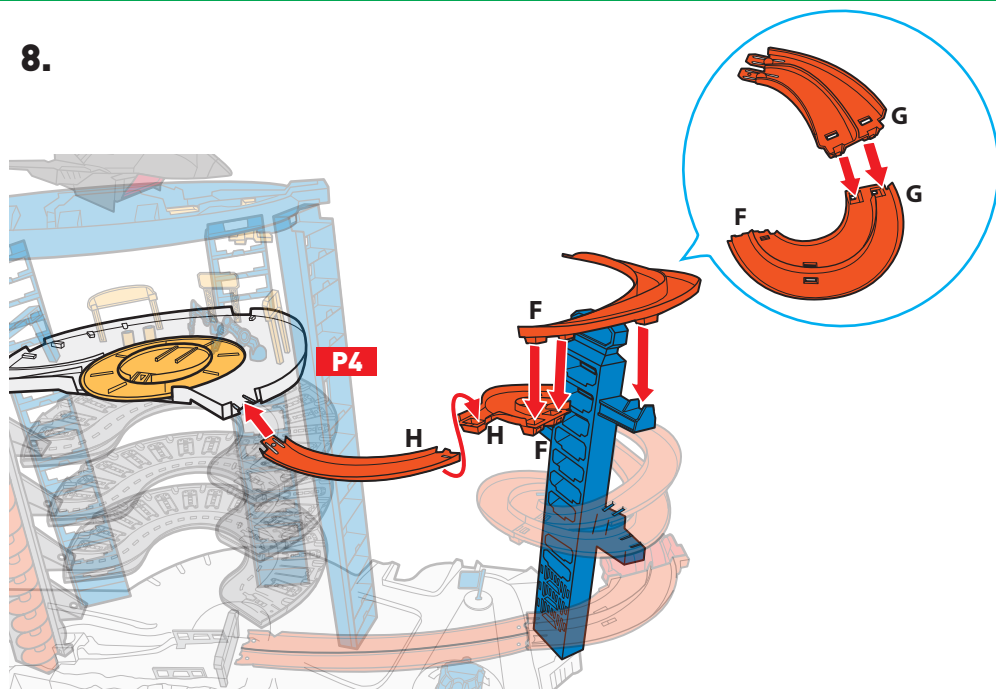

9. TOP VIEW

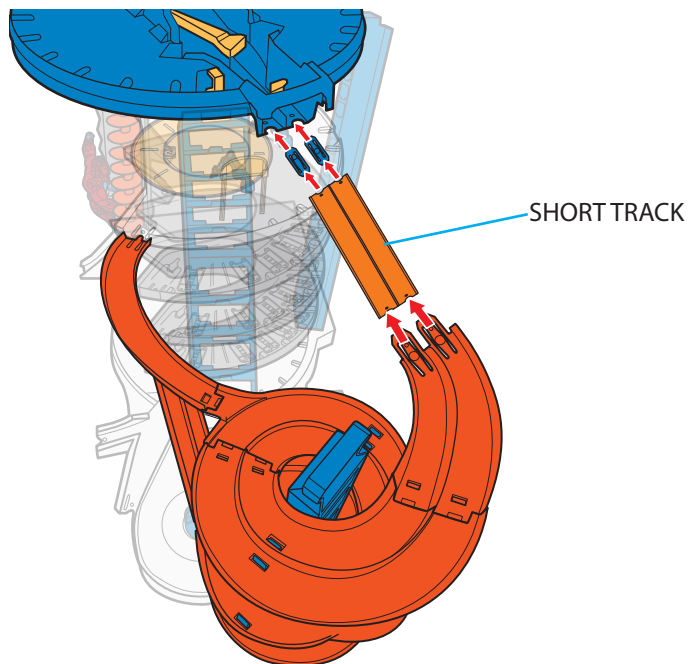

ZONE 4

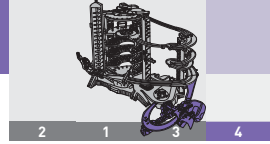

1.

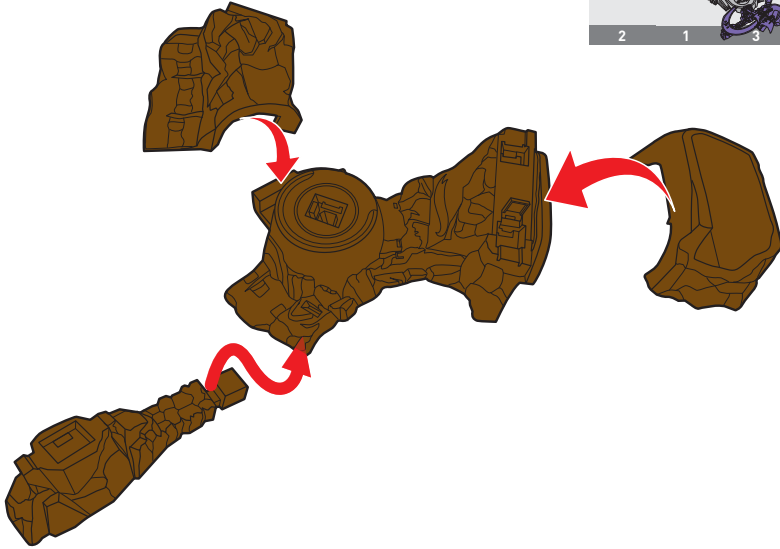

2.

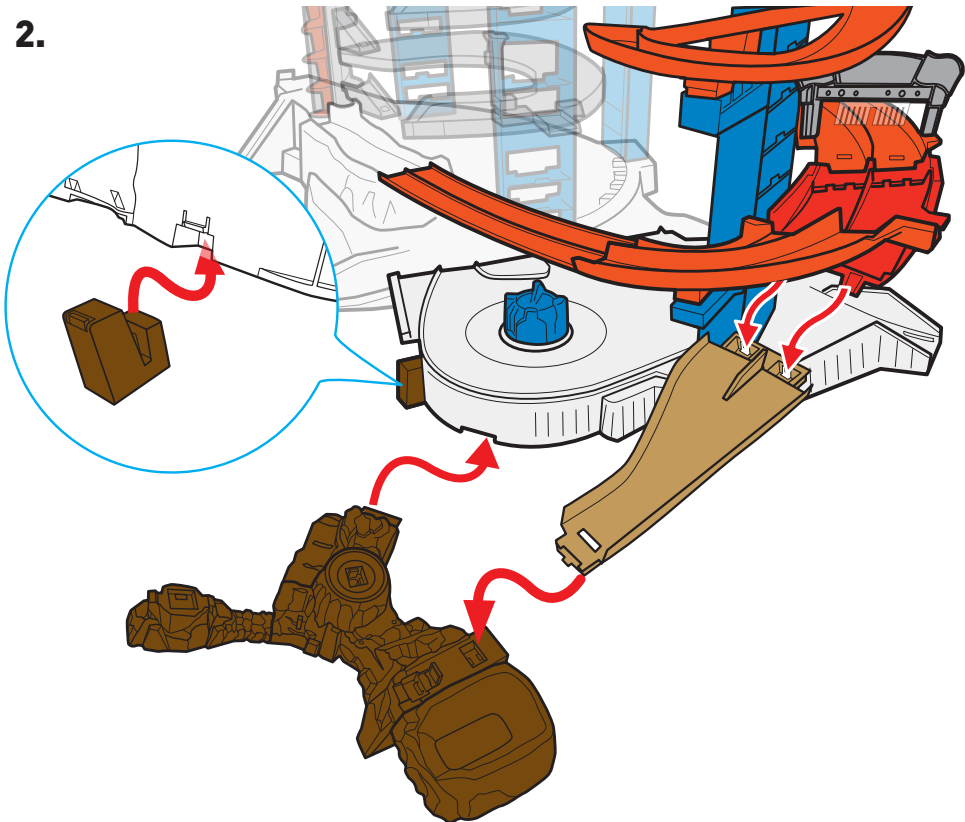

ASSEMBLY
ZONE 4

3.

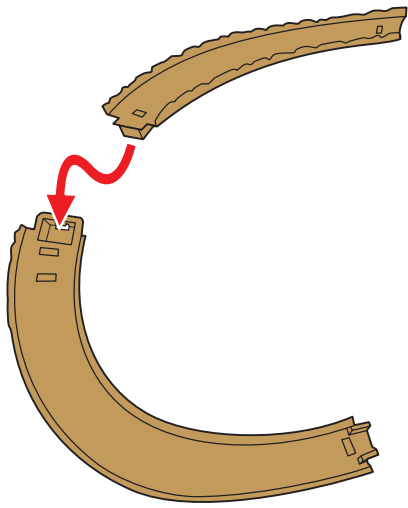

4.

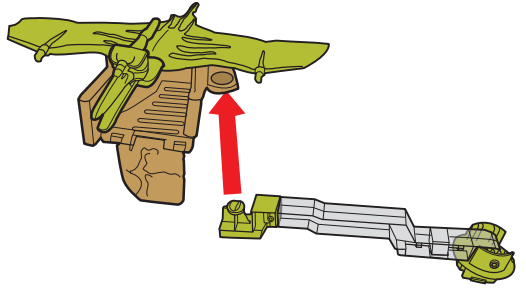

5.

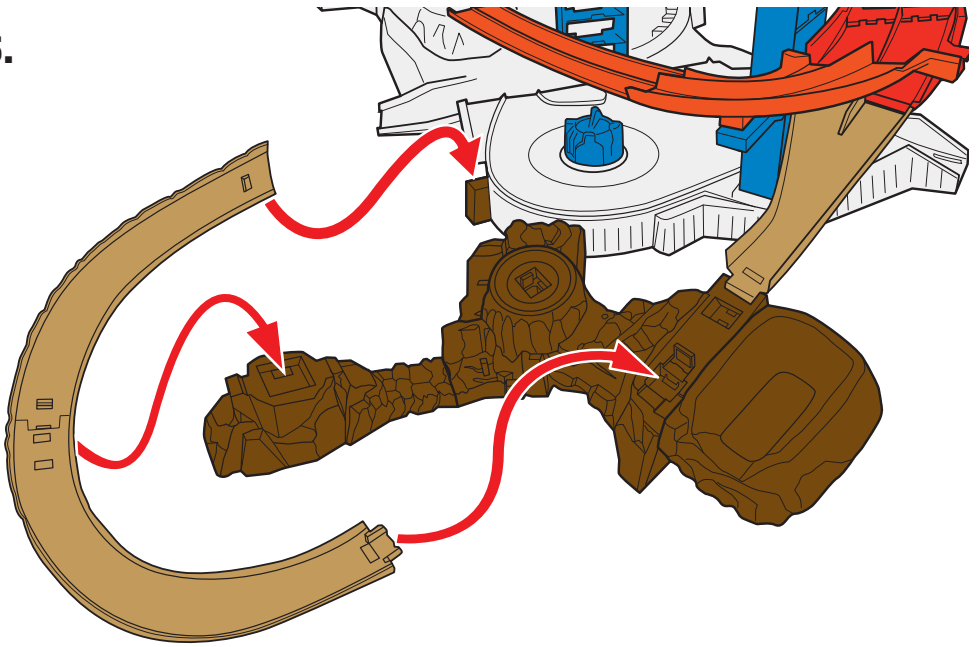

6.

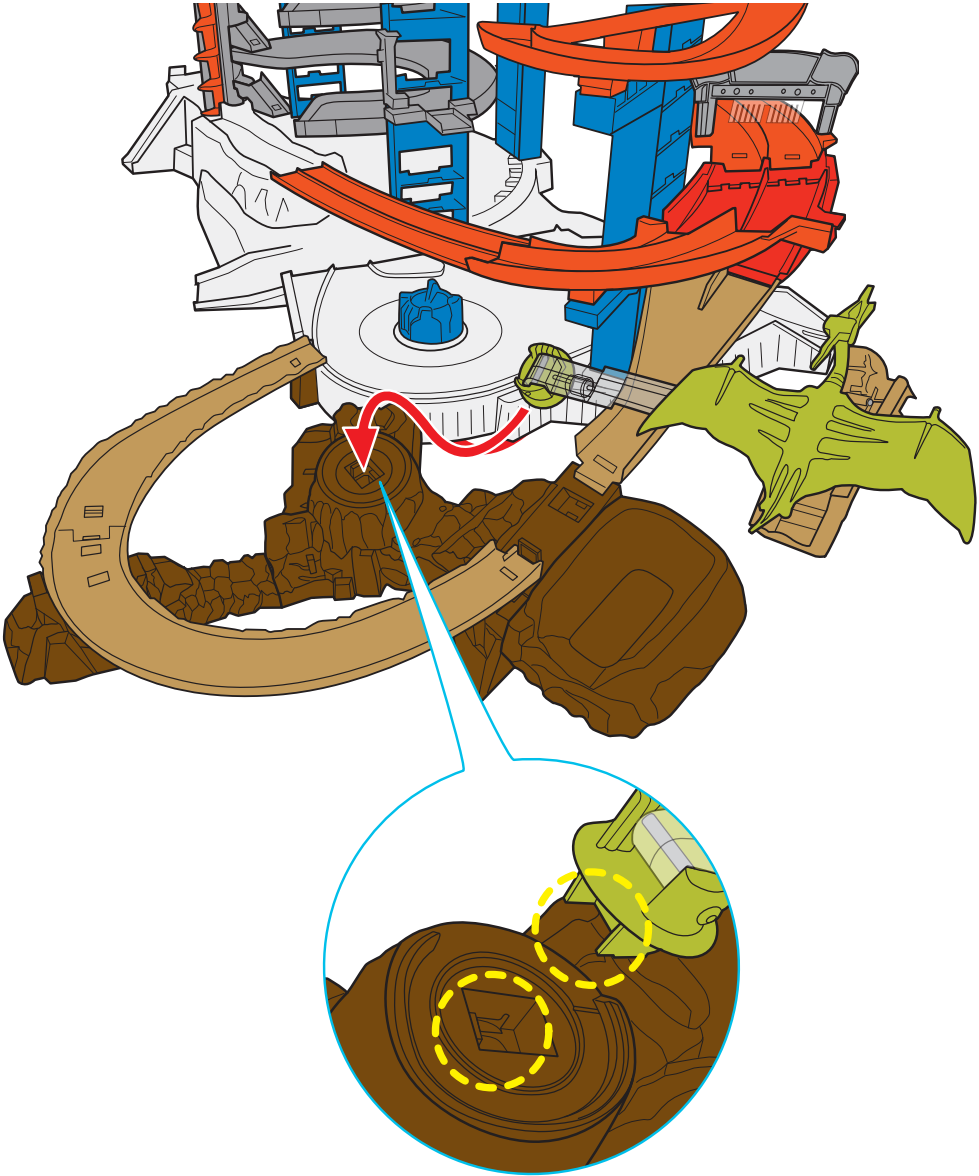
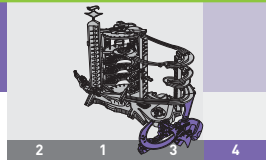

ASSEMBLY
ZONE 4

TO PLAY

GORILLA ATTACK!

1. POWER ON. LOAD VEHICLES TO RIDE UP THE ELEVATOR!

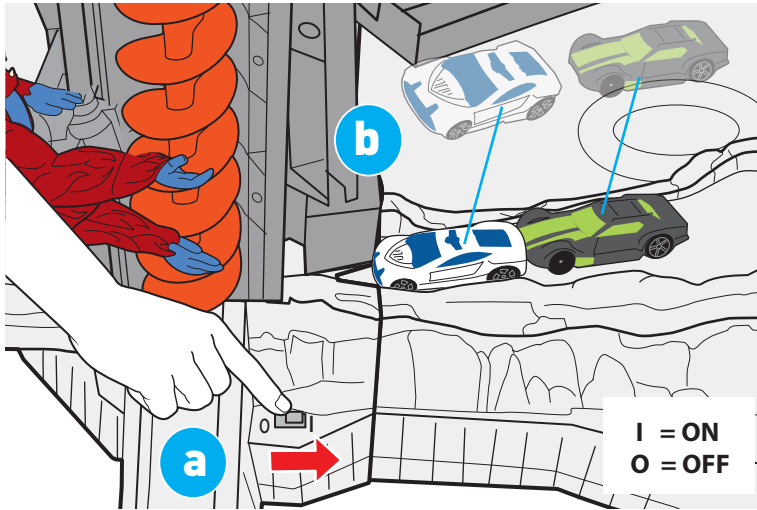

NOT FOR USE WITH SOME HOT WHEELS® VEHICLES.

2. THERE'S A GIANT GORILLA CLIMBING UP THE TOWER!
WATCH OUT! HE MIGHT KNOCK OUT YOUR VEHICLES!

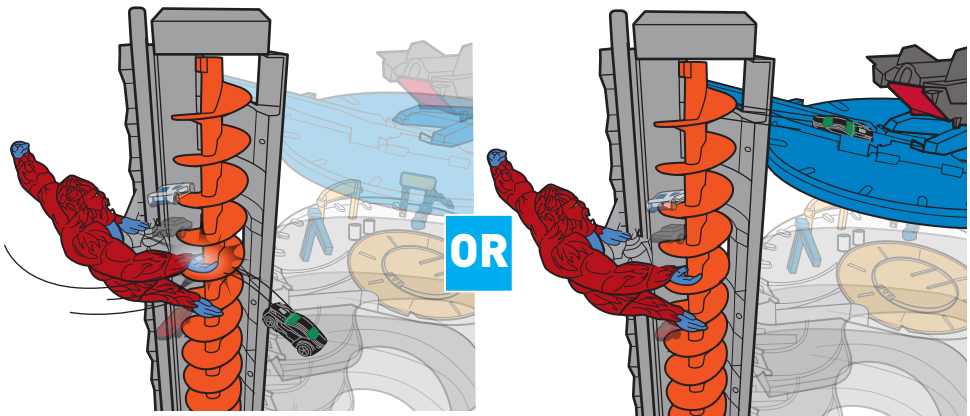

WARNING: DON'T STAY UNDER THE GORILLA BECAUSE IT WILL DROP DOWN.

RACE SIDE-BY-SIDE TWO DIFFERENT WAYS!

1. PRESS THE STARTING BAR DOWN TO LAUNCH A SIDE-BY-SIDE RACE!
2. PRESS THE BAR FARTHER DOWN AND LOCK IT INTO PLACE FOR NON-STOP CONTINUOUS RACING!
(NOTE: PULL UP TO UNLOCK THE STARTING BAR.)

SET UP

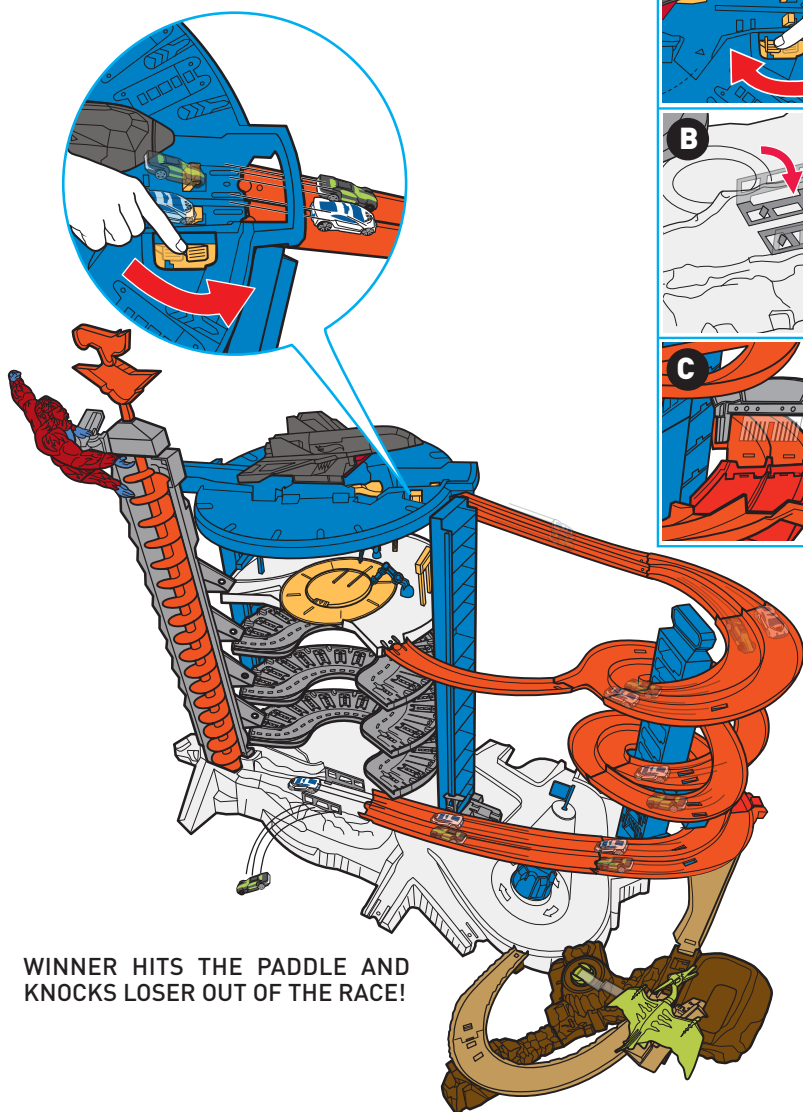
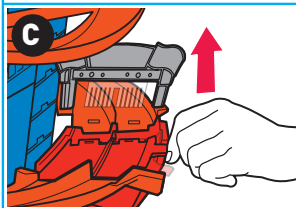
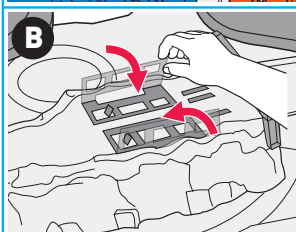
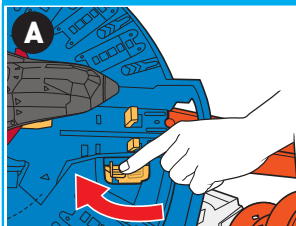

WINNER HITS THE PADDLE AND KNOCKS LOSER OUT OF THE RACE!

TO PLAY

PTERODACTYL STRIKE!

1. CHANGE LANE AND SET UP THE PTERODACTYL.

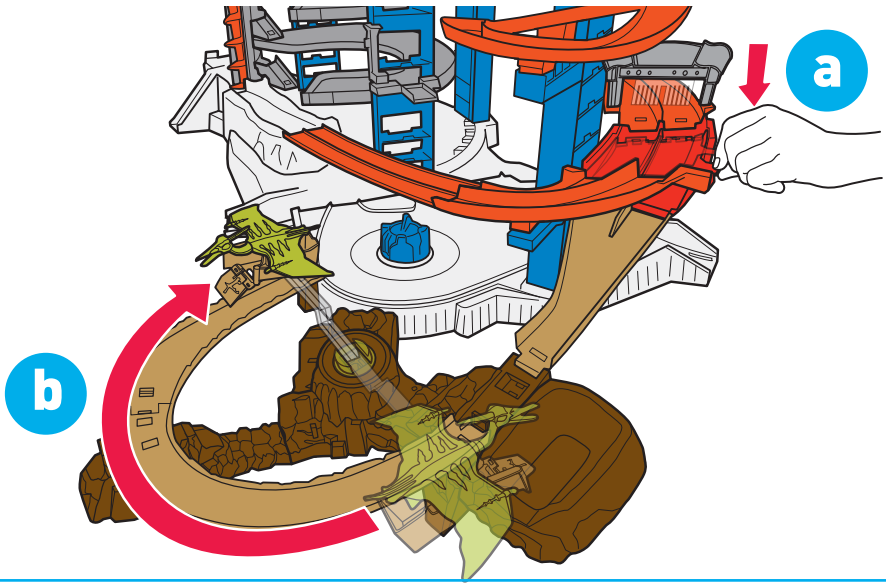

2. HEADS UP! DASH PAST THE SOARING PTERODACTYL BEFORE IT CAPTURES AND DROPS YOUR VEHICLE INTO THE NEST!

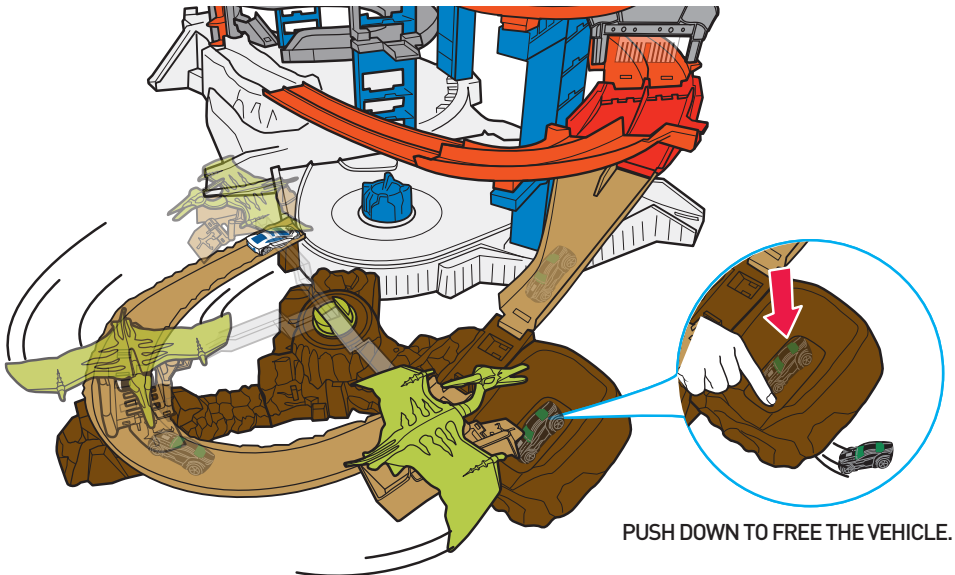

FLY THE JET!

1. LOAD & LAUNCH OR TRANSPORT TWO VEHICLES ON EACH "FLIGHT".

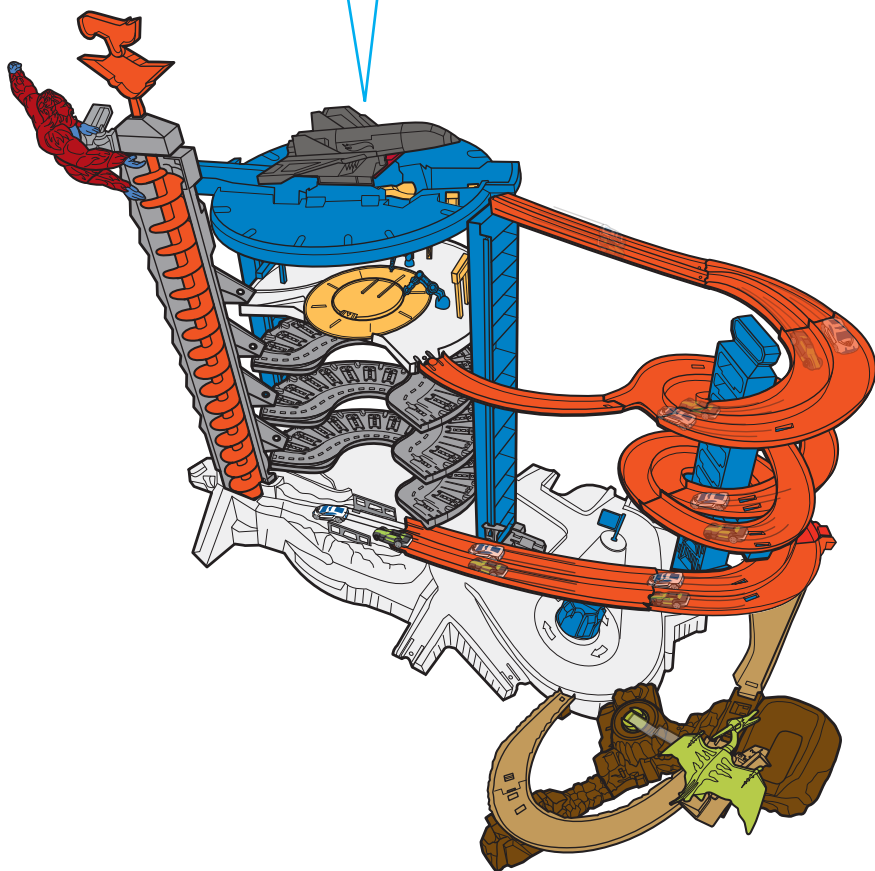
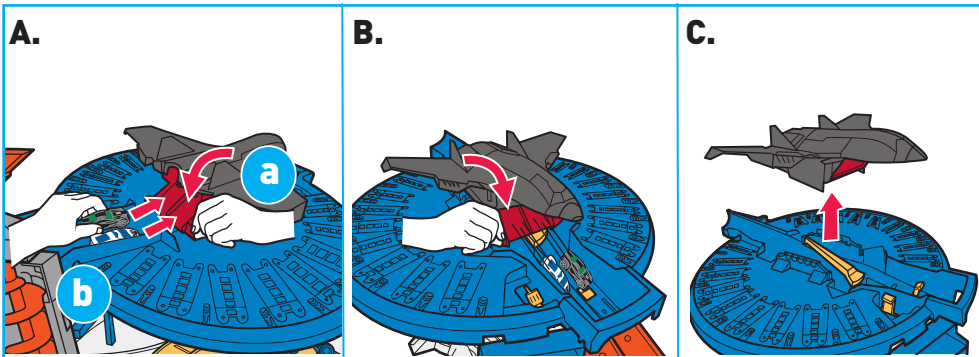

TO PLAY

WORK ON YOUR VEHICLE!

1. OPEN THE GATE AND STOP BY THE SERVICE LEVEL.

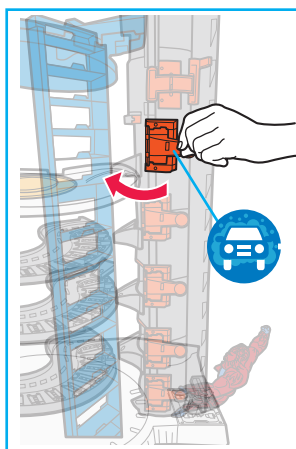

BACK VIEW

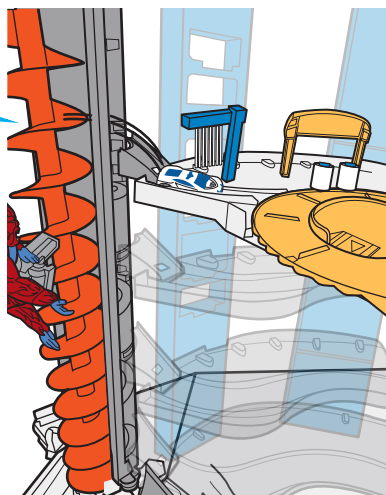

2. SPIN TURNTABLE AND MOVE ROBOTIC ARMS TO TUNE-UP YOUR VEHICLES.

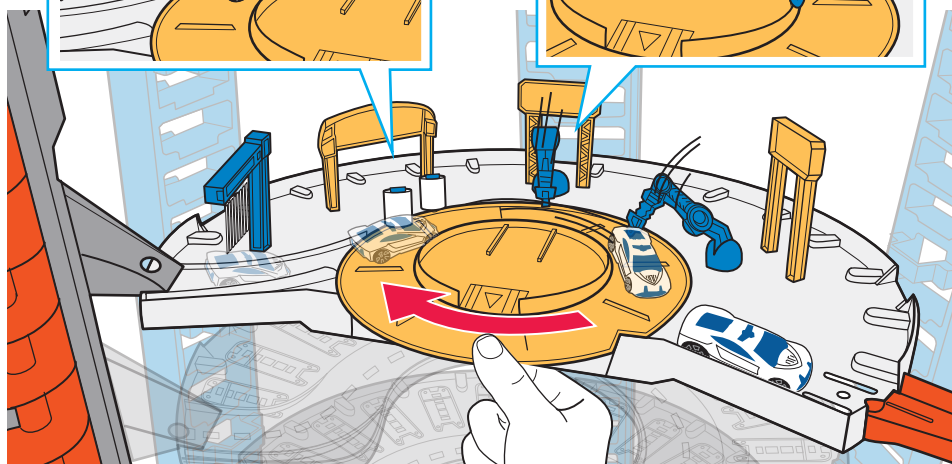
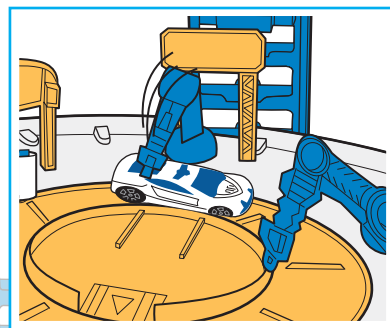
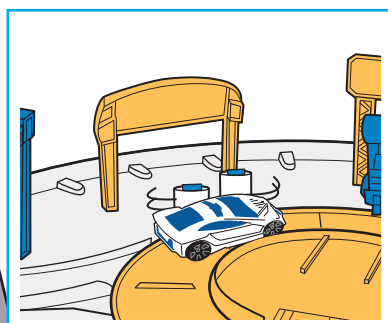

PARK YOUR VEHICLES!

1. GET ONTO DIFFERENT LEVELS BY THE MOTORIZED ELEVATOR...

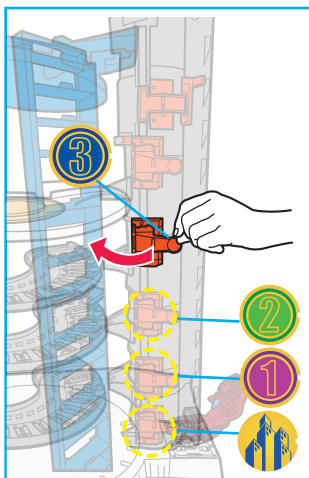

BACK VIEW

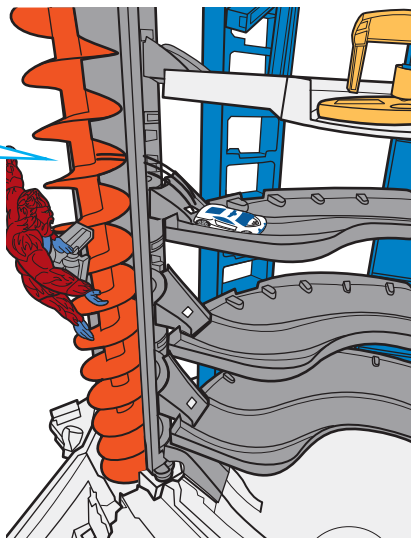

2. ...OR TAKE A RIDE ON THE CAR LIFT.

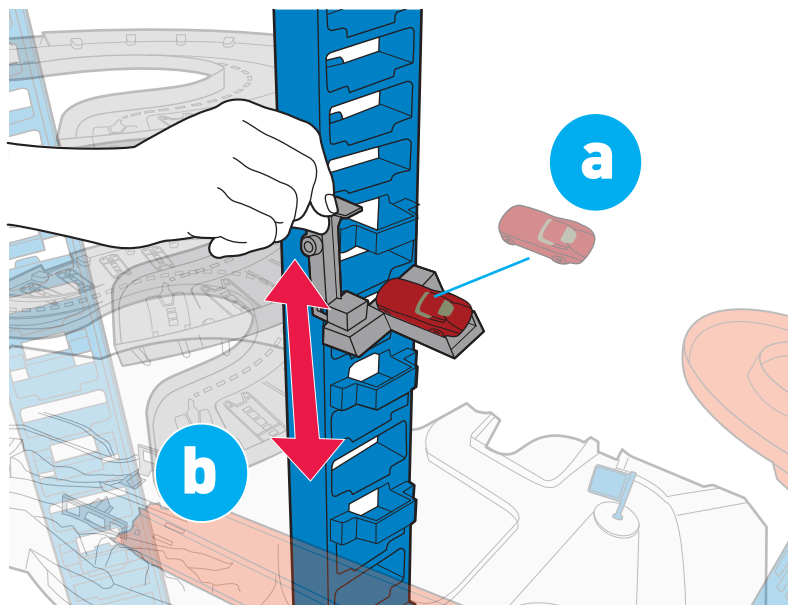

TO PLAY

- 3.** USE THE PARKING ZONES ON EACH LEVEL TO STORE YOUR VEHICLES.
YOU CAN PARK OVER 140 VEHICLES!

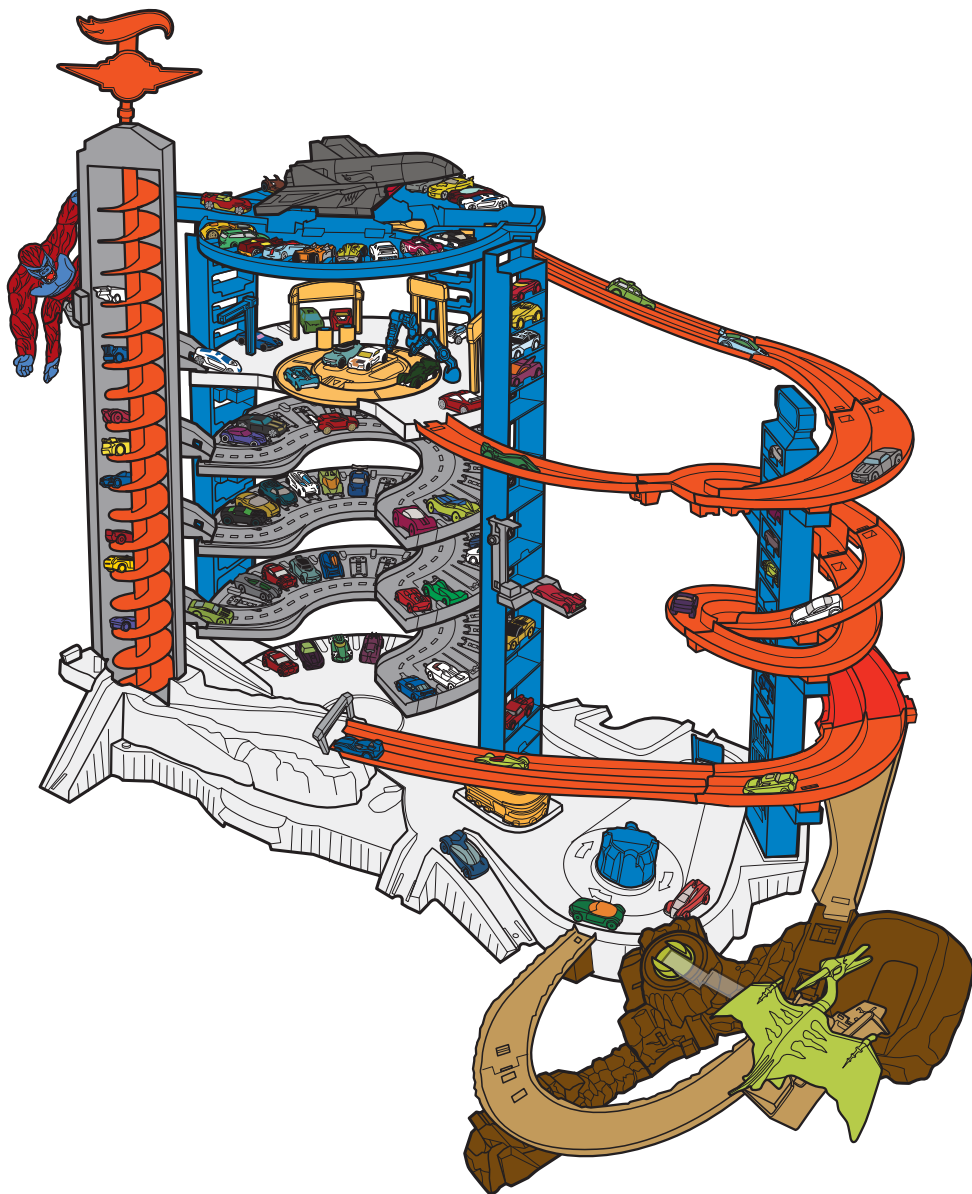

MORE WAYS TO PLAY

CONNECT TO OTHER HOT WHEELS® SETS (SOLD SEPARATELY).

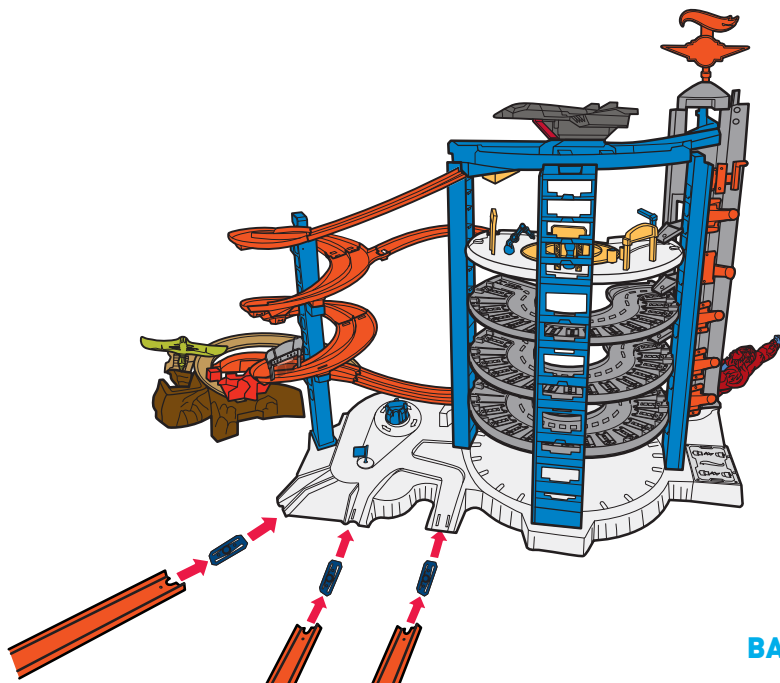
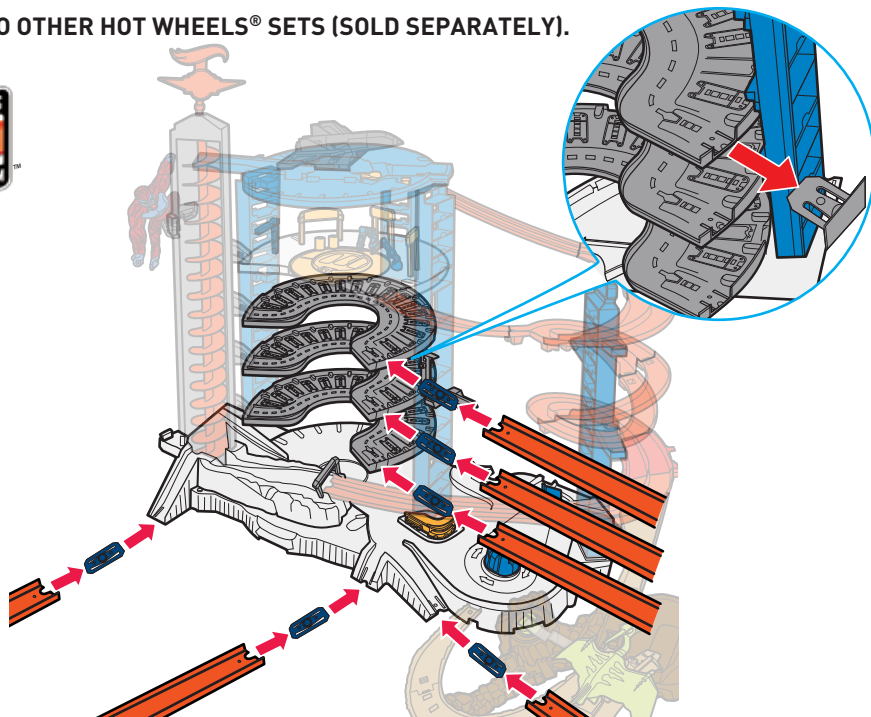

BACK VIEW

PERFORMANCE TIPS

Q. My vehicle is jammed in the elevator. What should I do?

A. Switch off the playset wherever your vehicle is jammed and take out the vehicle to resume normal operation.

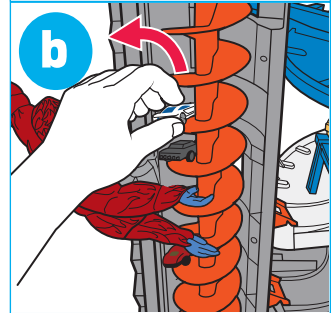
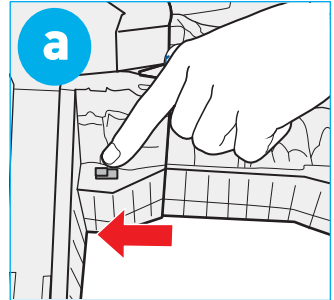

Q. My vehicle keeps crashing on the track for no reason. What is the problem?

A. Clear all obstructions on the track. Adjust track side walls at each connection point and make sure they are assembled either inside or outside of the track tabs, as described in the assembly steps.

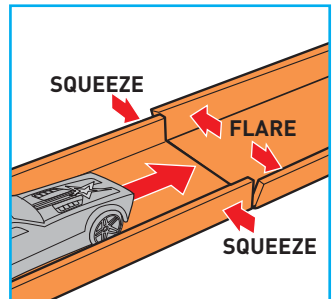

Q. My vehicle keeps slowing down by itself on the track. What is the problem?

A. Lint may collect around your vehicle's axles. This may cause the vehicle to run slowly. Use tweezers or a toothpick to remove lint.

