

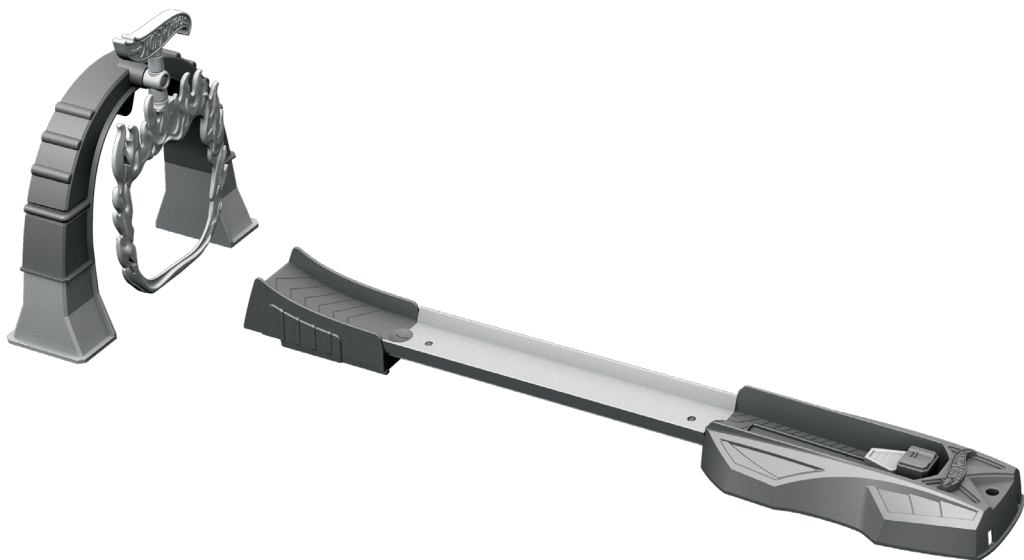

INSTRUCTIONS · INSTRUCCIONES
MODE D'EMPLOI · INSTRUÇÕES



PLEASE KEEP THESE INSTRUCTIONS FOR FUTURE REFERENCE AS THEY CONTAIN IMPORTANT INFORMATION. • LEE Y GUARDA ESTAS INSTRUCCIONES PARA FUTURA REFERENCIA, YA QUE CONTIENEN INFORMACIÓN DE IMPORTANCIA ACERCA DE ESTE PRODUCTO. • CONSERVER CE MODE D'EMPLOI POUR S'Y RÉFÉRER EN CAS DE BESOIN CAR IL CONTIENT DES INFORMATIONS IMPORTANTES. • POR FAVOR, GUARDE ESTAS INSTRUÇÕES PARA FUTURA REFERÊNCIA, POIS CONTÉM INFORMAÇÕES IMPORTANTES.

4-10

service.mattel.com

HOTWHEELS.COM



ASST. FTH79

FTH81-4B70

1101529475-4LB

ASST.FWM85

FWM87-4B70

1101913598-4LB

CONTENTS · CONTENIDO
CONTENU · CONTEÚDO

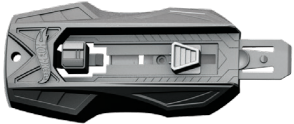

ASSEMBLY · MONTAJE
ASSEMBLAGE · MONTAGEM

1.

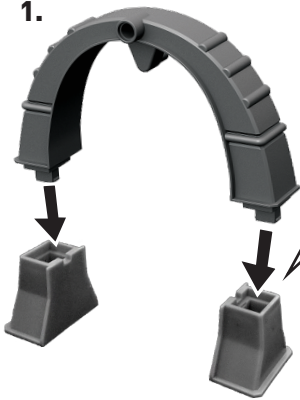

2.

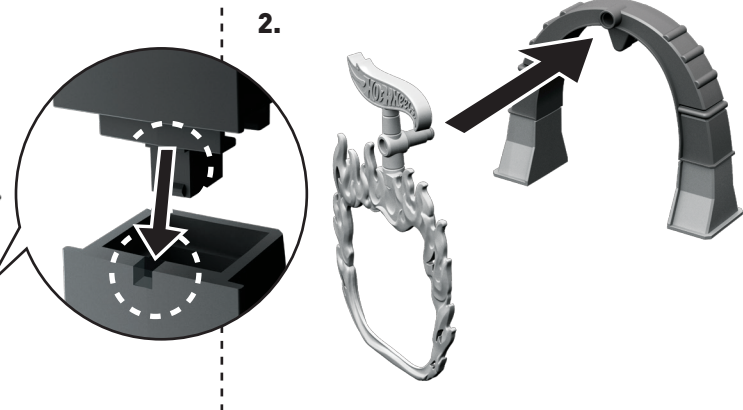

3.



**TO PLAY · PARA JUGAR
POUR JOUER · COMO BRINCAR**

- 1. LOCK LAUNCHER AND LOAD VEHICLE.
AJUSTA EL LANZADOR Y COLOCA EL VEHÍCULO.
ENCLANCHER LE LANCEUR ET METTRE LE VÉHICULE EN PLACE.
TRAVE O LANÇADOR E COLOQUE O VEÍCULO.**

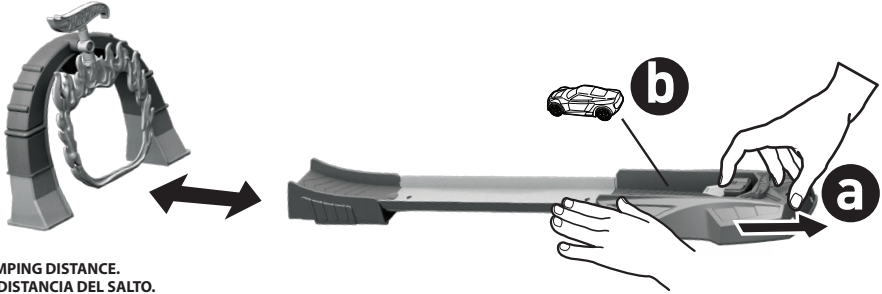

ADJUST JUMPING DISTANCE.
AJUSTA LA DISTANCIA DEL SALTO.
AJUSTER LA DISTANCE DE SAUT.
AJUSTE A DISTÂNCIA DO SALTO.

- 2. SWING THE FLAME AND PRESS THE CAR LAUNCHER!
¡MUEVE LAS LLAMAS Y PRESIONA EL LANZADOR!
FAIRE BALANCER LES FLAMMES ET APPUYER SUR LE LANCEUR.
BALANCE A CHAMA E APERTE O LANÇADOR DE CARRO!**

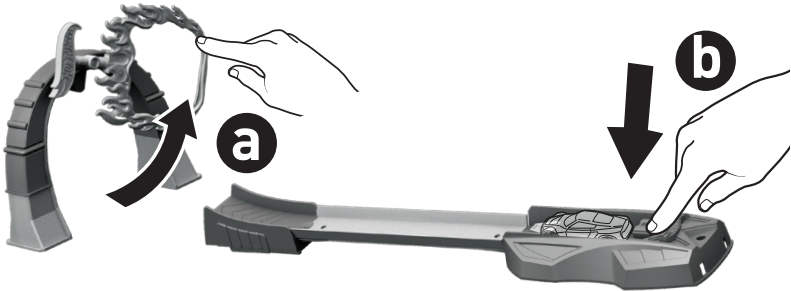

- A. WILL YOU CRASH INTO "FIRE"? · ¿CHOCARÁS CONTRA LAS LLAMAS?
LA VOITURE PERCUTERA-T-ELLE LES FLAMMES? · SERÁ QUE VOCÉ V-
AI BATER NO FOGO?**

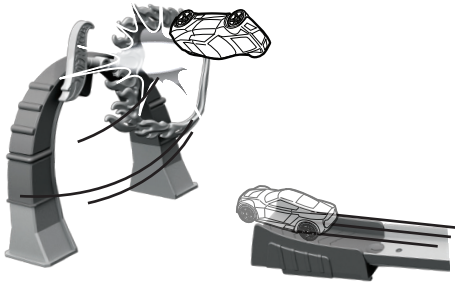

- B. OR CAN YOU JUMP THROUGH THE FLAME?
¿O SALTARÁS Y ATRAVESARÁS EL ARO EN LLAMAS?
OU VA-T-ELLE TRAVERSER LES FLAMMES?
OU SERÁ QUE CONSEGUE PULAR O FOGO?**

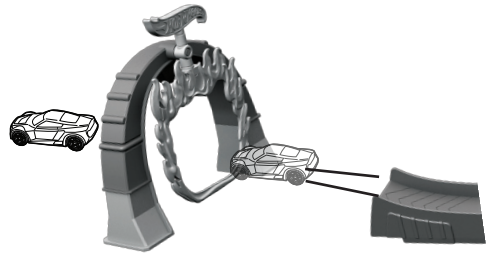

NOT FOR USE WITH SOME HOT WHEELS® VEHICLES.
NO COMPATIBLE CON ALGUNOS VEHÍCULOS HOT WHEELS.
NON COMPATIBLE AVEC CERTAINS VÉHICULES HOT WHEELS.
NÃO É COMPATÍVEL COM ALGUNS VEÍCULOS HOT WHEELS.

STORAGE · ALMACENAMIENTO RANGEMENT · PARA GUARDAR

- 1. DETACH RAMP. · QUITA LA RAMPA.
ENLEVER LA RAMPE. · REMOVA A RAMPA.**



- 2. FLIP OVER RAMP TO STORE VEHICLE.
VOLTEA LA RAMPA PARA GUARDAR EL VEHÍCULO.
RETOURNER LA RAMPE POUR RANGER LE VÉHICULE.
VIRE A RAMPA PARA GUARDAR O VEÍCULO.**

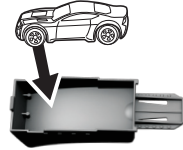

- 3. ATTACH RAMP UNDER LAUNCHER.
CONECTA LA RAMPA DEBAJO DEL LANZADOR.
FIXER LE RAMPE SOUS LE LANCEUR.
ENCAIXE A RAMPA SOB O LANÇADOR.**



**BOTTOM VIEW
VISTA DE ABAJO
VUE DE DESSOUS
VISÃO DA BASE**

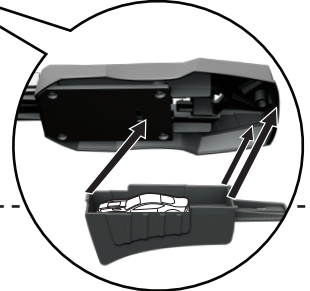

- 4. FLIP OVER LAUNCHER TO ATTACH STAND.
VOLTEA EL LANZADOR PARA CONECTAR LA BASE.
RETOURNER LE LANCEUR POUR FIXER LE SOCLE.
VIRE O LANÇADOR PARA ENCAIXAR O SUPORTE.**

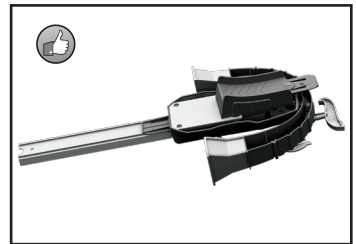
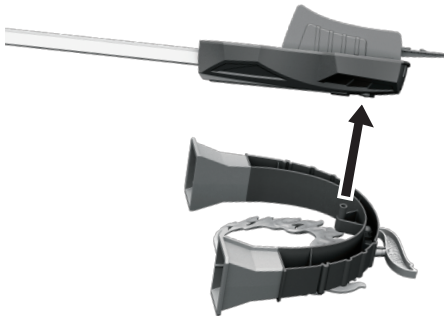

©2018 Mattel, Mattel, Inc., 636 Girard Avenue, East Aurora, NY 14052, U.S.A. Consumer Services 1-800-524-8697. Mattel Canada Inc., Mississauga, Ontario L5R 3W2. You may call us free at / Composez sans frais le 1-800-524-8697. Mattel Australia Pty., Ltd., Richmond, Victoria. 3121. Consumer Advisory Service - 1300 135 312. Mattel East Asia Ltd., Room 503-09, North Tower, World Finance Centre, Harbour City, Tsimshatsui, HK, China. Tel.: (852) 3185-6500. Diimport & Diedarkan Oleh: Mattel Southeast Asia Pte. Ltd., No 19-1, Tower 3 Avenue 7, Bangsar South City, No 8, Jalan Kerinchi, 59200 Kuala Lumpur, Malaysia. Tel: 03-33419052. Mattel U.K. Ltd., Vanwall Business Park, Maidenhead SL6 4UB. Importado y distribuido por Mattel de México, S.A. de C.V., Miguel de Cervantes Saavedra No. 193, Pisos 10 y 11, Col. Granada, Delegación Miguel Hidalgo, C.P. 11520, México, Ciudad de México. R.F.C. MME-920701-NB3. Tels.: 59-05-51-00 Ext. 5206 ó 01-800-463-59-89. Mattel Chile, S.A., Avenida Américo Vespucio 501-B, Quilicura, Santiago, Tel.: 1230-020-6213. Servicio al consumidor Venezuela: Tel.: 0-800-100-9123. Mattel Argentina, S.A., Curupaytí 1186, (1607) - Villa Adelina, Buenos Aires. Tel.: 0800-666-3373. Mattel Colombia, S.A., Calle 123#7-07 P.5, Bogotá. Tel.: 01800-710-2069. Mattel Perú, S.A., Av. Juan de Arona # 151, Centro Empresarial Juan de Arona, Torre C, Piso 7, Oficina 704, San Isidro, Lima 27, Perú. RUC: 20425853865. Reg. Importador: 02350-12-JUE-DIGESA. Tel.: 0800-54744. E-mail Latinoamérica: Servicio.Clientes@Mattel.com. Distribuido por : Mattel do Brasil Ltda. - CNPJ : 54.558.002/0001-20 - Rua Verbo Divino, 1488 - 2º. Andar - 04719-904 - Chácara Santo Antônio - São Paulo - SP - Brasil. Serviço de Atendimento ao Consumidor: fone 0800-550780. E-mail: sac@mattel.com. Mattel France, Parc de la Cerisaie, 1/3/5 allée des Fleurs, 94263 Fresnes Cedex. N° Cristal 0969 36 99 99 (Numéro non surtaxé) ou www.lesjouetsmattel.fr. Mattel España, S.A., Aribau 200. 08036 Barcelona. cservice.spain@mattel.com. Tel: 902203010. http://www.service.mattel.com/es. Mattel Portugal Lda., Edifício Amoreiras Square, Rua Carlos Alberto da Mota Pinto nº 17 - 3º A, 1070-313 Lisboa. Tel. Número Verde: 800 10 10 71 - consumidor@mattel.com. Mattel South Africa (PTY) LTD, Office 102 13, 30 Melrose Boulevard, Johannesburg 2196.