

# IMAGINE WHAT YOU COULD DO WITH THE TRACK BUILDER SYSTEM!

ADVERTISEMENT



**CONNECT  
TO OTHER  
SETS!**



FOR MORE EPIC TRACK IDEAS VISIT

[WWW.HOTWHEELS.COM/TRACKBUILDER](http://WWW.HOTWHEELS.COM/TRACKBUILDER)

EACH SOLD SEPARATELY. SUBJECT TO AVAILABILITY.  
COLORS AND DECORATIONS MAY VARY.

©2018 Mattel. Mattel, Inc., 636 Girard Avenue, East Aurora, NY 14052, U.S.A. Consumer Services 1-800-524-8697. Mattel U.K. Ltd., Vanwall Business Park, Maidenhead SL6 4UB. Helpline 01628 500303. Mattel Australia Pty., Ltd., Richmond, Victoria. 3121. Consumer Advisory Service - 1300 135 312. Mattel South Africa (PTY) LTD, Office 102 13, 30 Melrose Boulevard, Johannesburg 2196. Mattel East Asia Ltd., Room 503-09, North Tower, World Finance Centre, Harbour City, Tsimshatsui, HK, China. Tel.: (852) 3185-6500. Diimport & Diedarkan Oleh: Mattel Southeast Asia Pte. Ltd., No 19-1, Tower 3 Avenue 7, Bangsar South City, No 8, Jalan Kerinchi, 59200 Kuala Lumpur, Malaysia. Tel: 03-33419052.



# BUILDER'S GUIDE

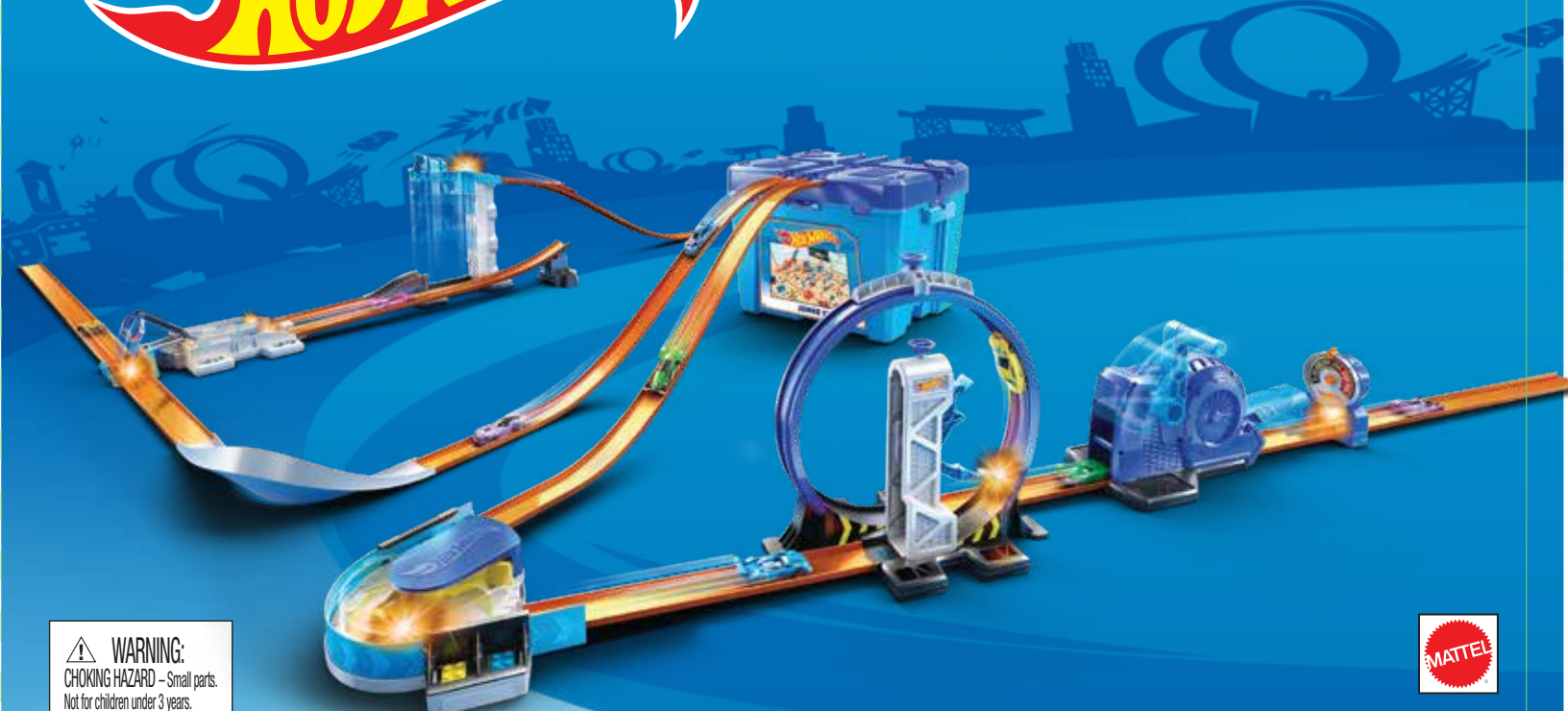

**WARNING:**  
CHOKING HAZARD - Small parts.  
Not for children under 3 years.

FVF18-0970  
1101417039-D0MG1

[service.mattel.com](http://service.mattel.com)

**HOTWHEELS.COM**

PLEASE KEEP THESE INSTRUCTION FOR FUTURE REFERENCE  
AS THEY CONTAIN IMPORTANT INFORMATION.



AGES

**6-12**

# JUMBO STUNT BOX

# HERE'S WHAT YOU GET

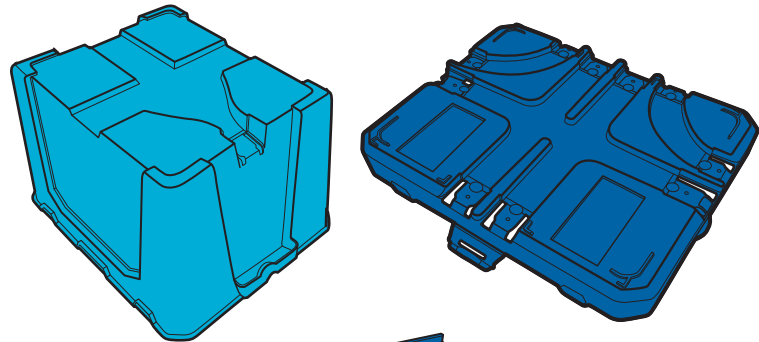

2x LOW WALL TRACKS

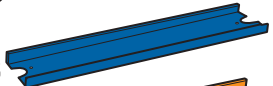

16x LOW WALL TRACKS



2x HIGH WALL TRACKS



12x



5x



2x

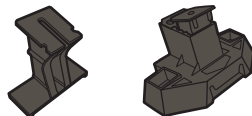

F

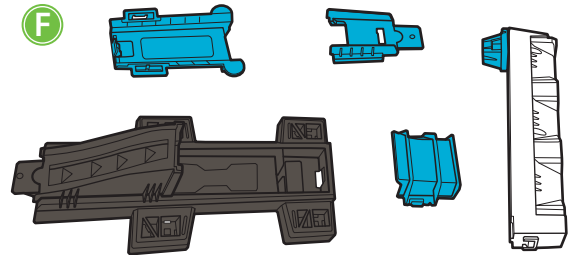

A

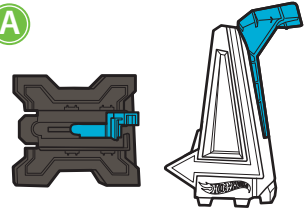

B

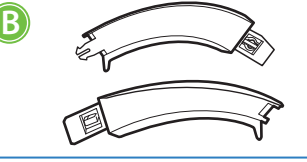

C

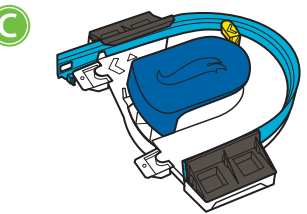

G

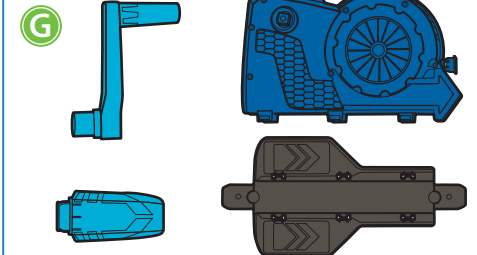

D

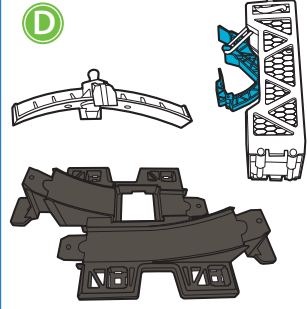

E

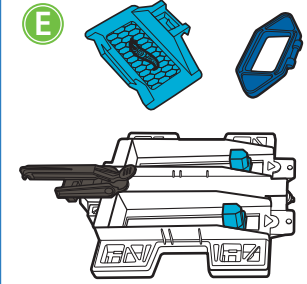

LABELS

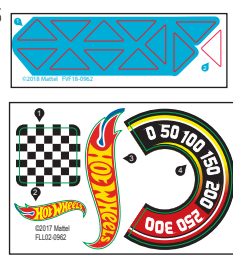

# APPLY LABELS

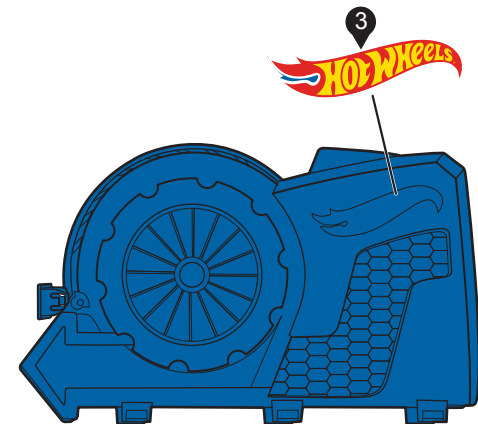
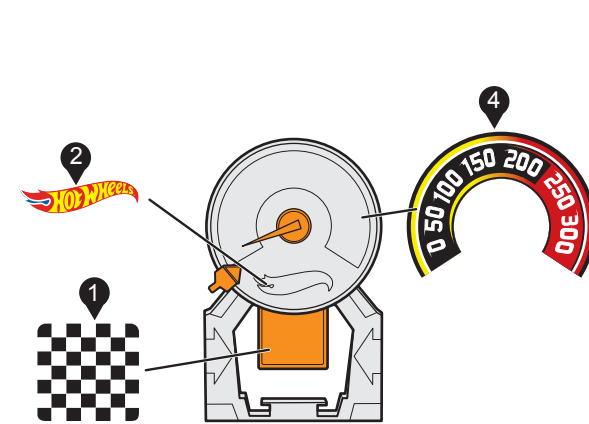
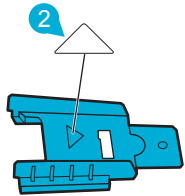
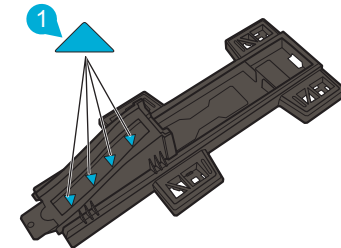
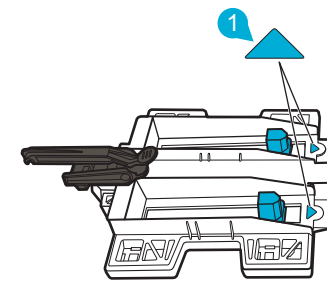
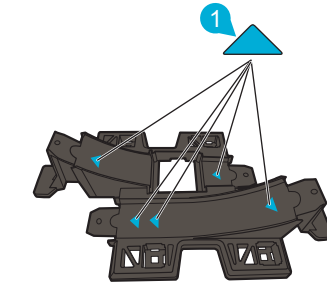
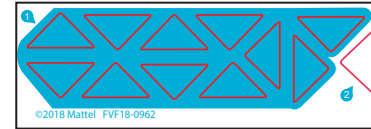

## BASIC PARTS **A** & **B**

HERE'S WHAT YOU NEED: 4 PIECES

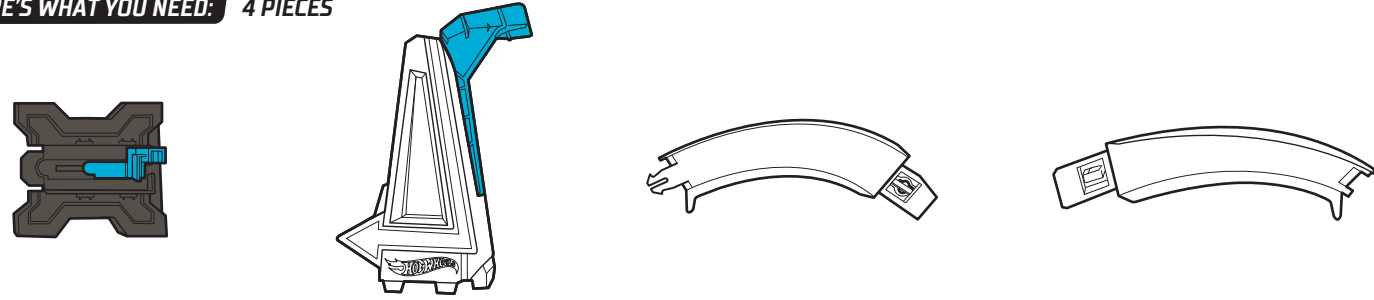

ASSEMBLY:

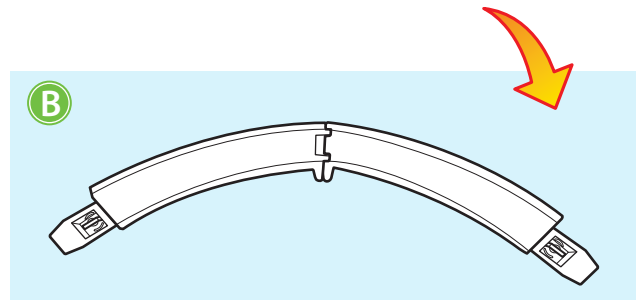
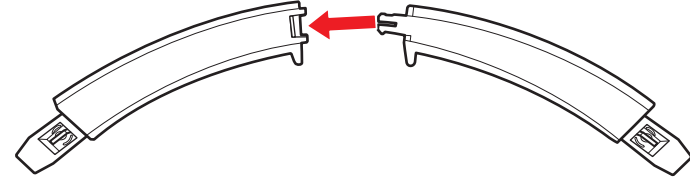
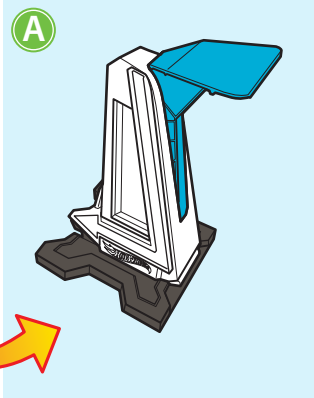
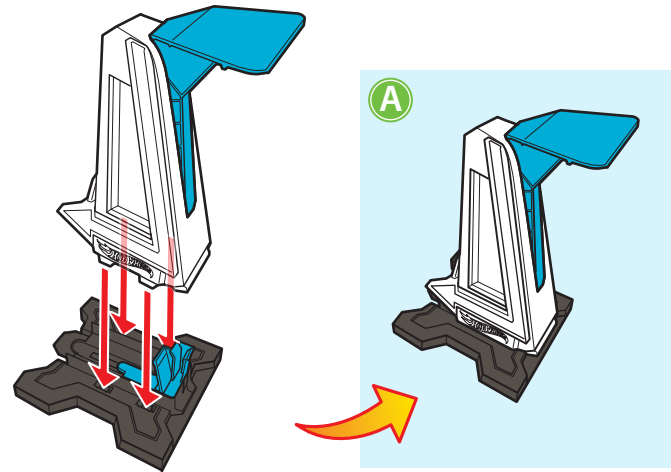

## BASIC PART **C**

HERE'S WHAT YOU NEED: 3 PIECES

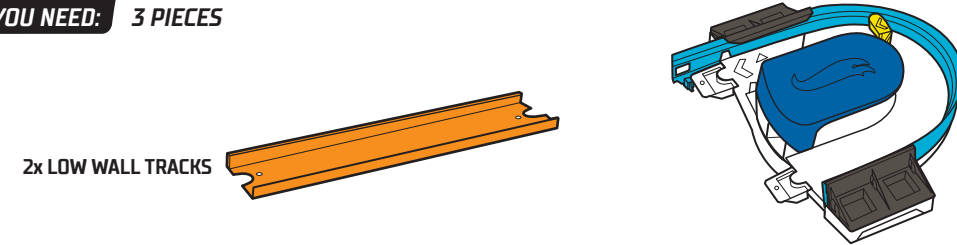

ASSEMBLY:

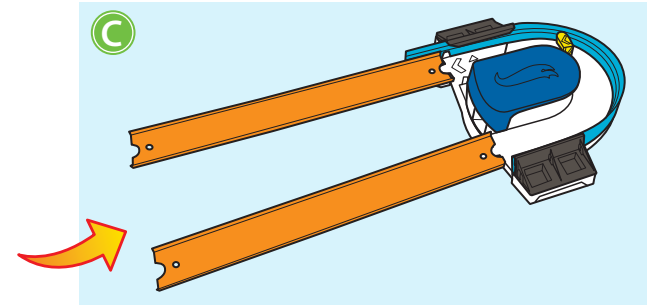
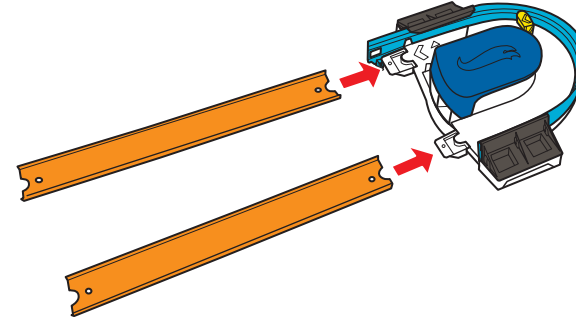

HERE'S HOW IT WORKS:

**1A.** PUSH BACK AND LOCK THE KICKER BEFORE PLAY.

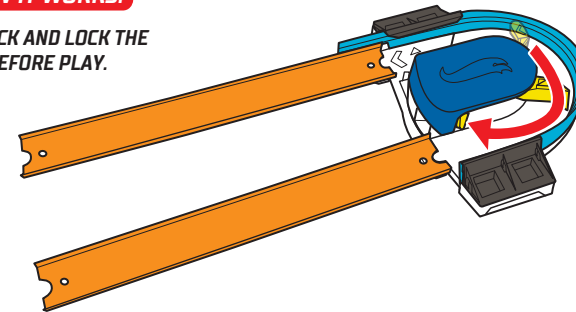

**1B.** KICK YOUR CAR AROUND THE TURN!

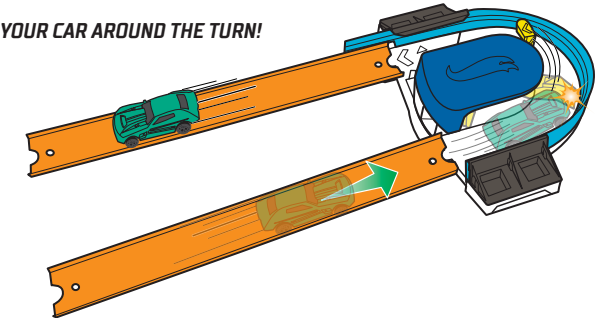



## BASIC PART C (CONTD.)

**2A.** MOVE THE TRACK TO ADJUST YOUR ANGLE.

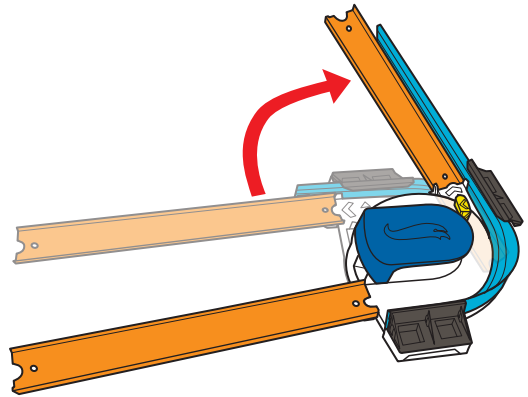

**2B.** RESET THE KICKER AND SPEED THROUGH THE TURN!

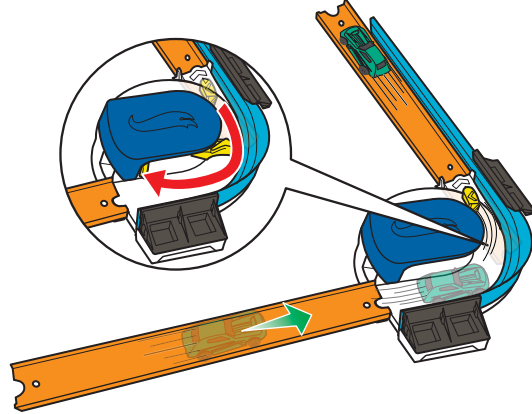

**3A.** RESET THE KICKER AND ADJUST THE ANGLE FOR STRAIGHT LAUNCH!

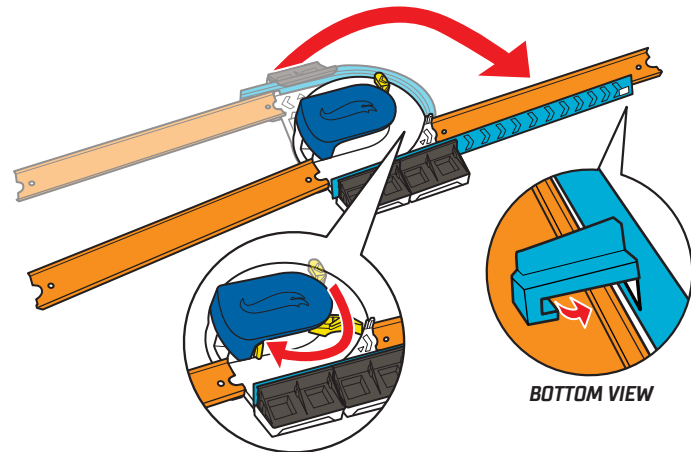

**3B.** RACE THROUGH THE KICKER AND OFF THE TRACK!

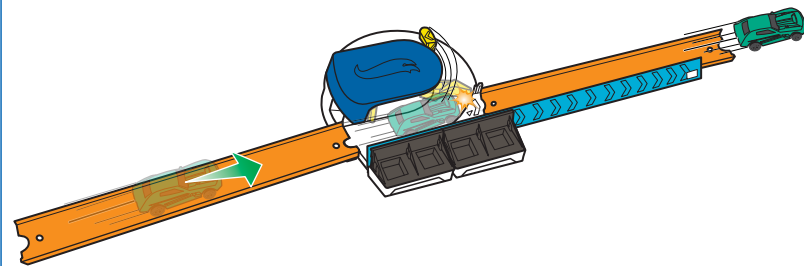

## BASIC PART D

**HERE'S WHAT YOU NEED:** 5 PIECES

2x LOW WALL TRACKS

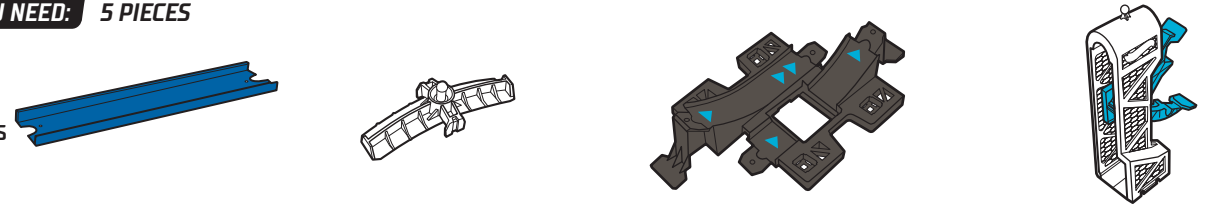

**ASSEMBLY:**

**1.**

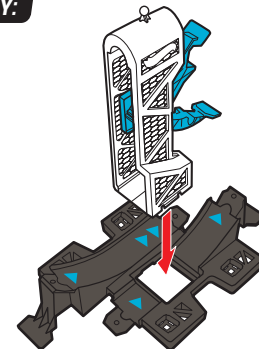

**2.**

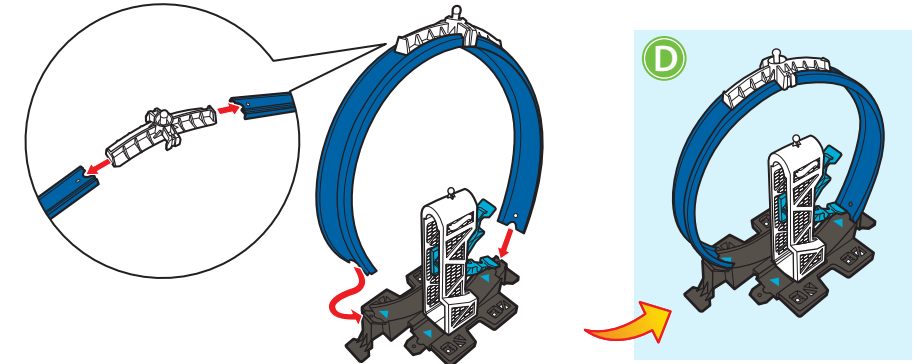

**HERE'S HOW IT WORKS:**

**1.** PULL BACK AND LOCK KICKER.

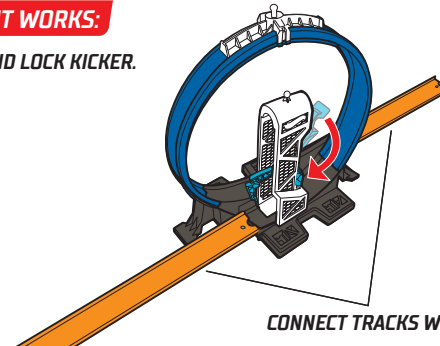

CONNECT TRACKS WHEN NECESSARY.

**2.** RACE INTO THE LOOP FOR A SPEED BOOST!

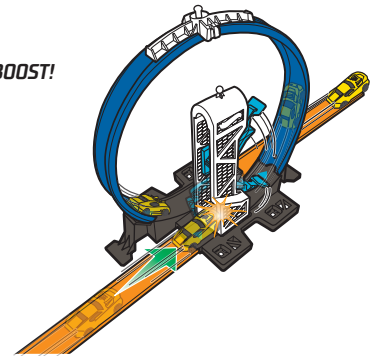

## BASIC PART E

HERE'S WHAT YOU NEED: 8 PIECES

4x LOW WALL TRACKS

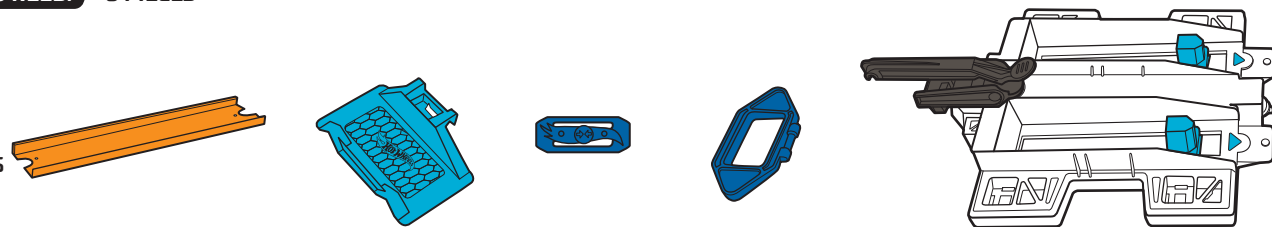

ASSEMBLY:

1.

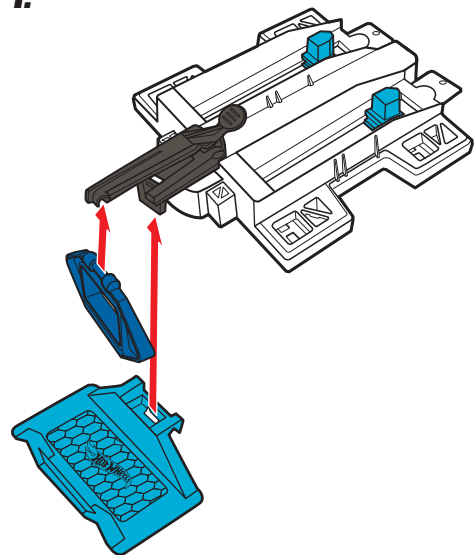

2.

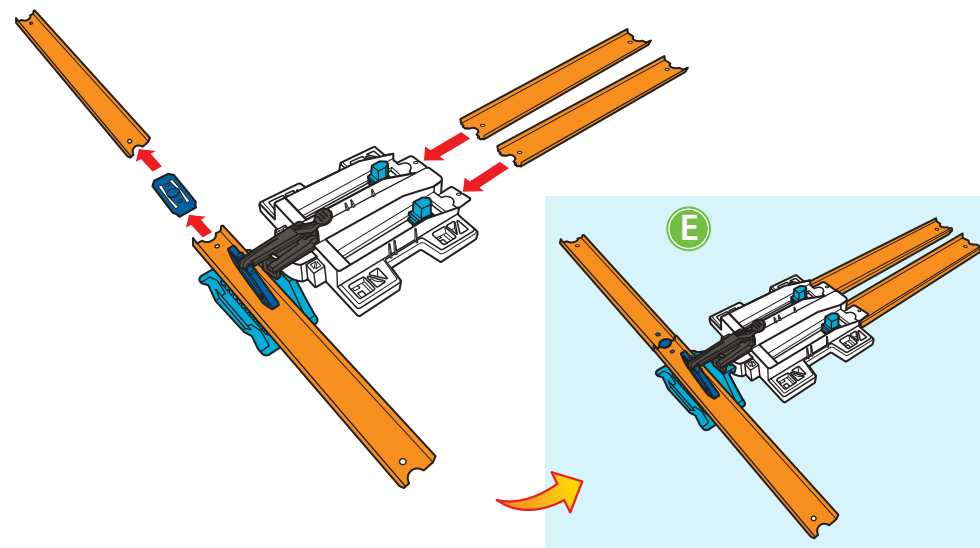

8

HERE'S HOW IT WORKS:

1. LOCK LAUNCHER BACK AND LOAD CARS.

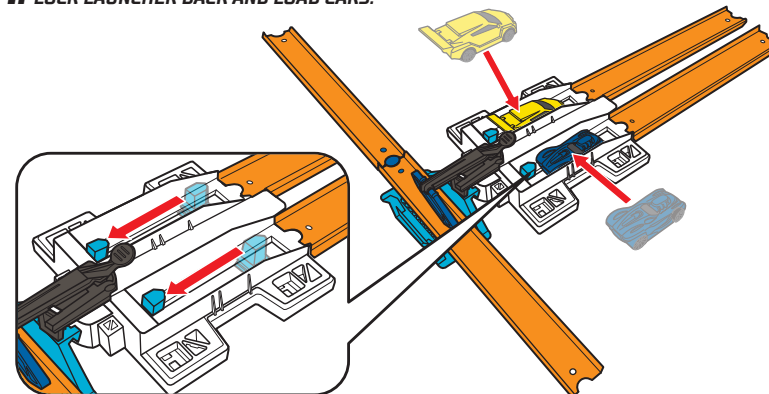

2A. PRESS BUTTON FOR A HEAD-TO-HEAD RACE!

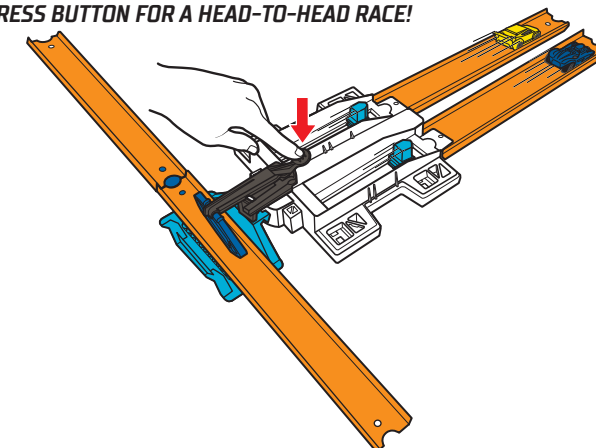

2B. OR ACTIVATE THE LAUNCHER BY A PASSING CAR!

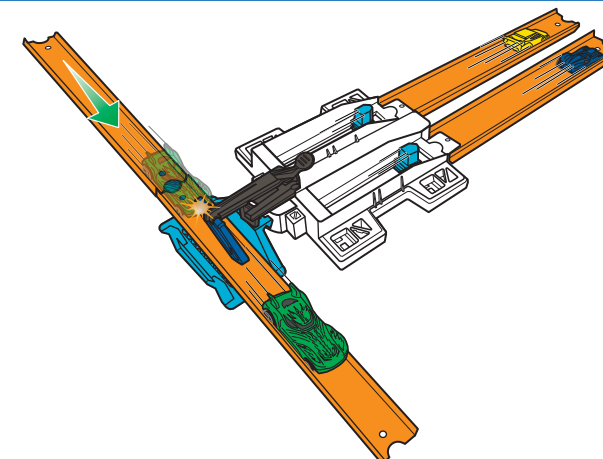

9

## BASIC PART F

HERE'S WHAT YOU NEED: 5 PIECES

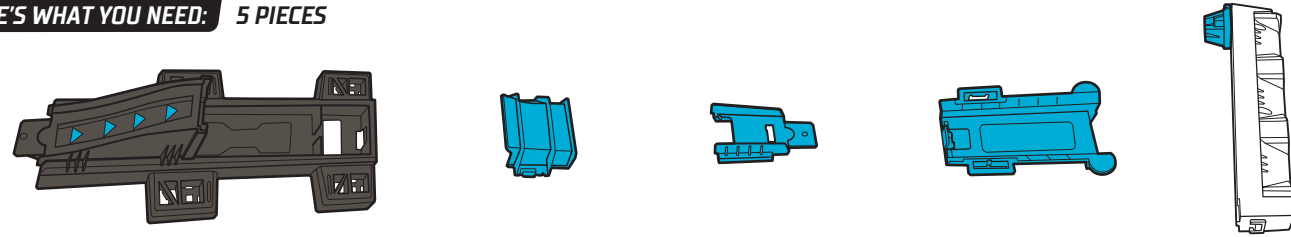

ASSEMBLY:

1.

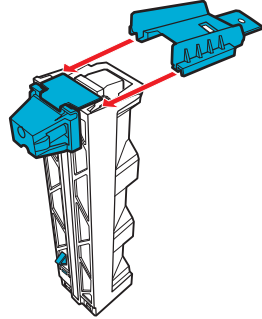

2.

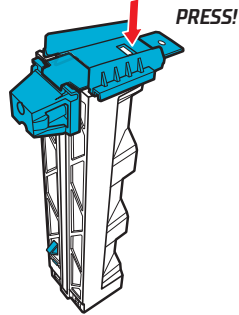

3.

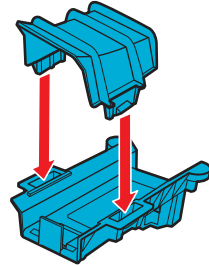

4.

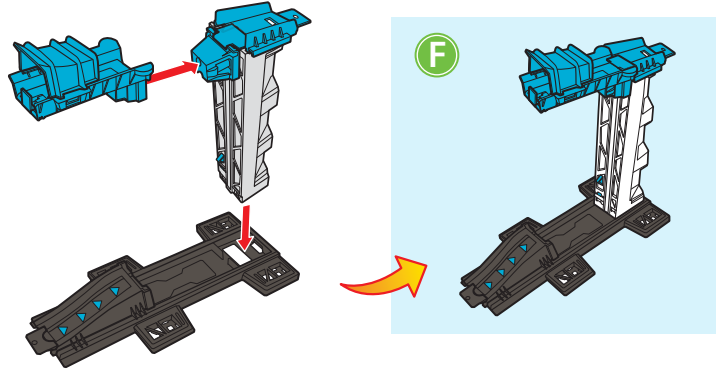

5.

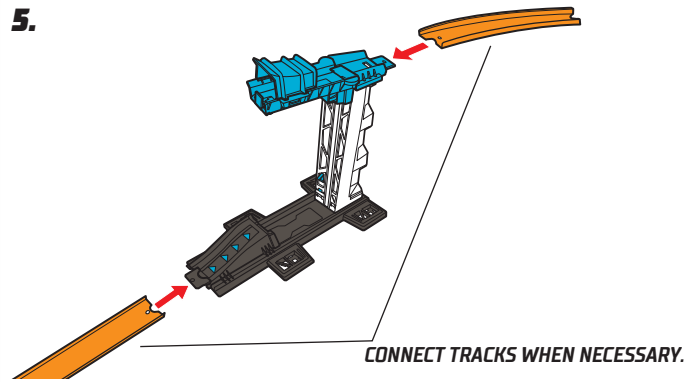

HERE'S HOW IT WORKS:

1. PUSH LIFT DOWN AND LOCK IN PLACE.

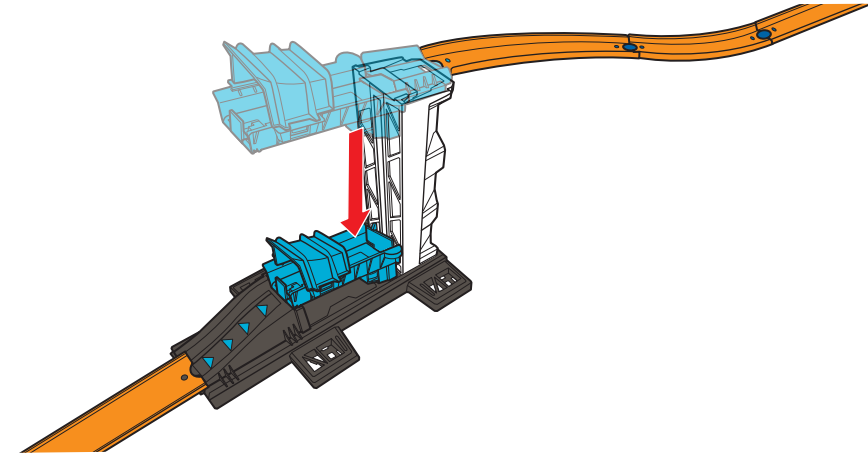

2. DRIVE YOUR CAR IN, THEN LIFT AND LAUNCH!

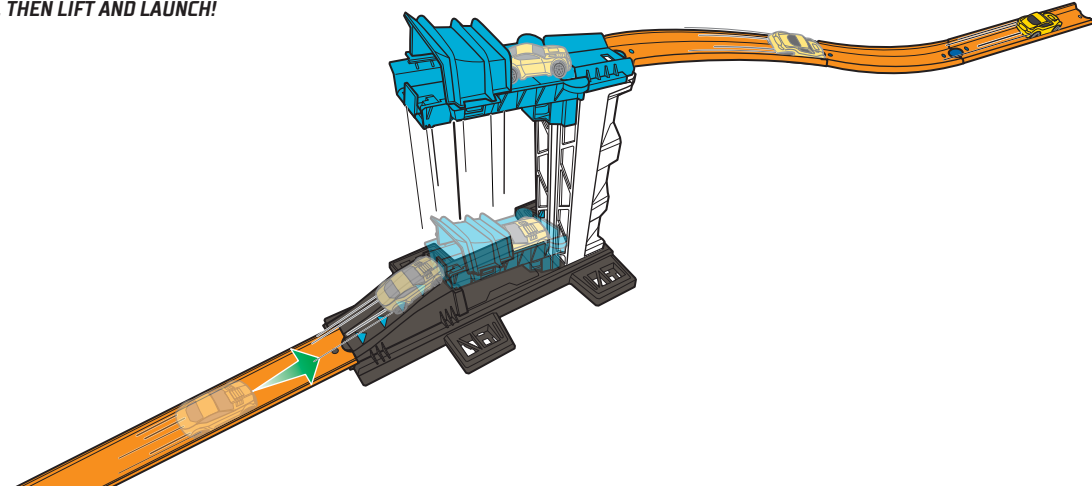

## BASIC PART G

**HERE'S WHAT YOU NEED:** 5 PIECES

1x LOW WALL TRACK

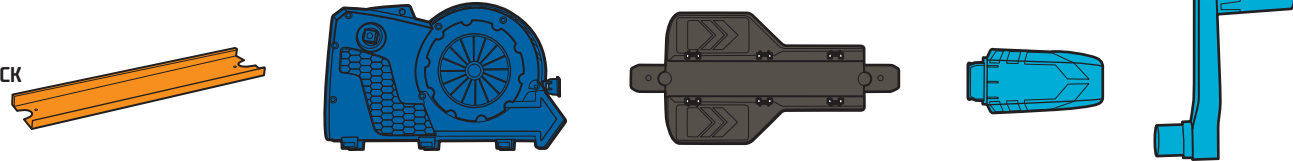

### ASSEMBLY:

**1. ATTACH HANDLE WITH A PHILLIPS HEAD SCREWDRIVER (NOT INCLUDED).**

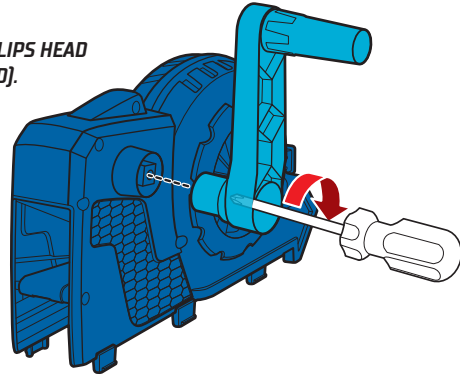

**2.**

ONE-TIME ASSEMBLY.

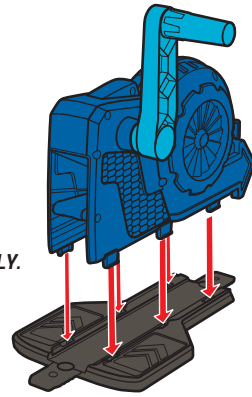

**3.**

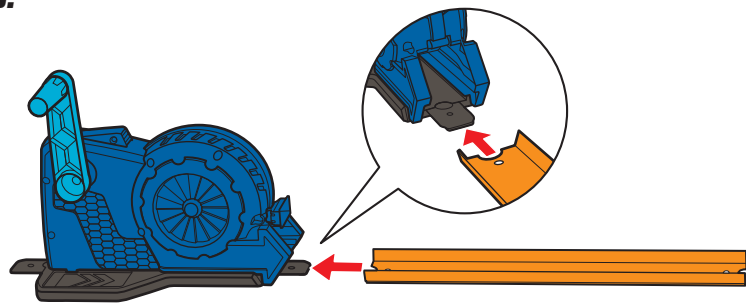

**4.**

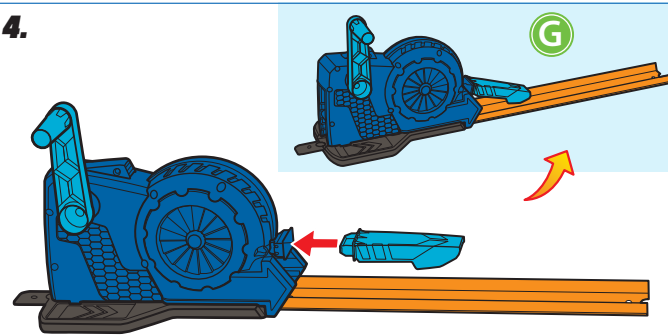

### HERE'S HOW IT WORKS:

**1. CRANK HANDLE TO REV BOOSTER.**

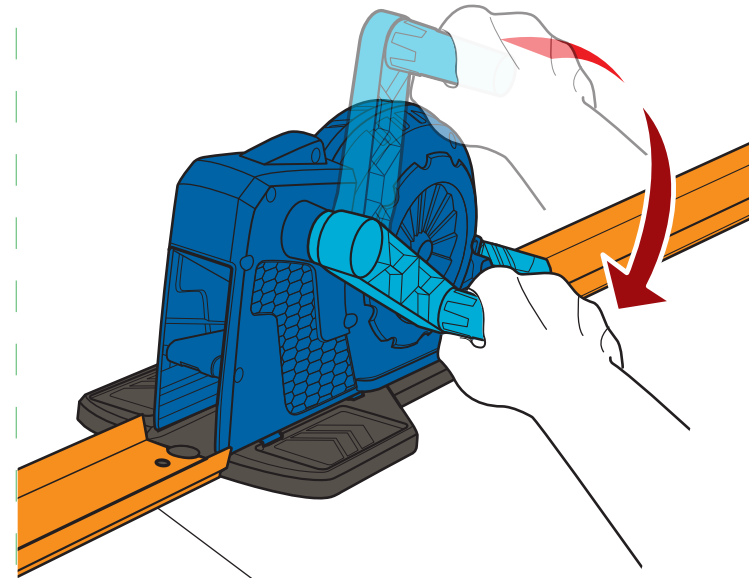

CONNECT TRACK WHEN NECESSARY.

**2. LAUNCH WHEN BOOSTER IS STILL REVVING!**

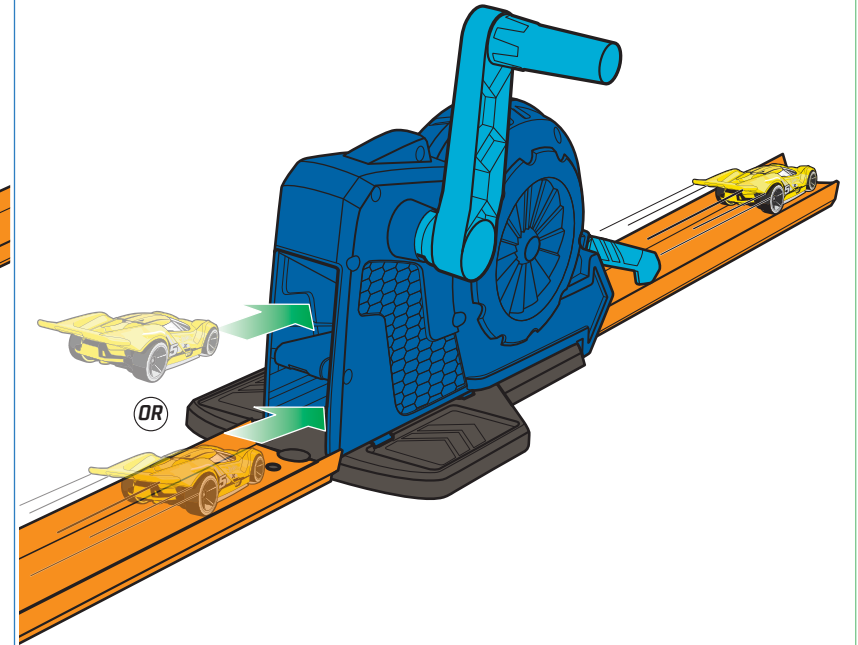

# WHAT WILL YOU BUILD FIRST?

TIP: ASSEMBLE ALL BASIC PARTS BEFORE CONSTRUCTING THE BUILDS.

## BUILD 1

PAGE 16

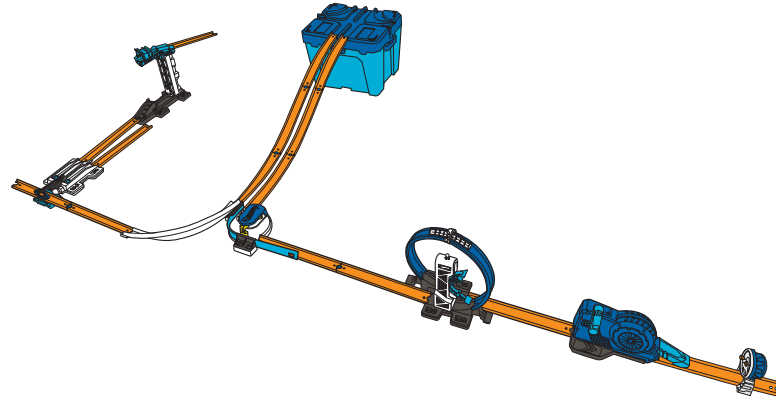

## BUILD 3

PAGE 20

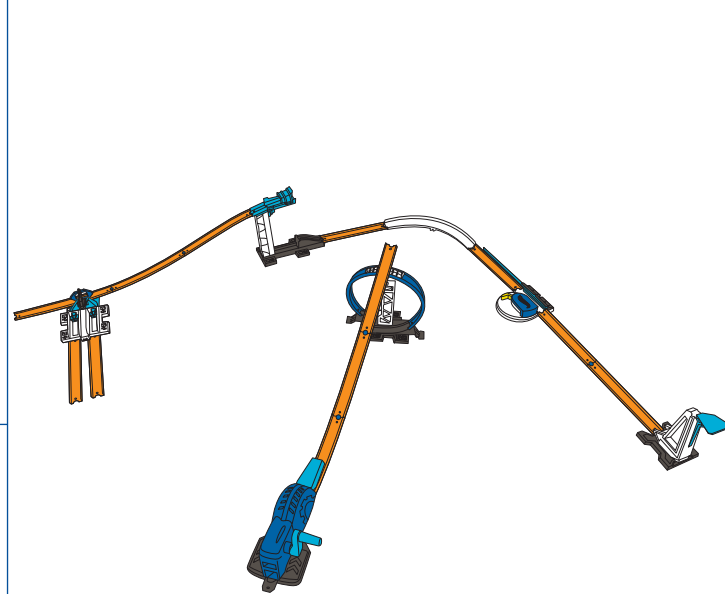

## BUILD 2

PAGE 18

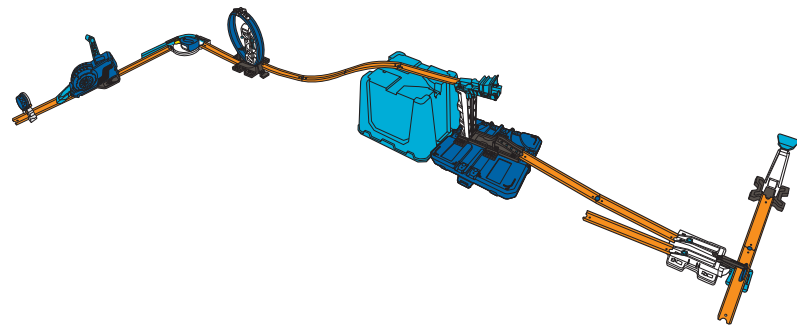

## BUILD 4

PAGE 22

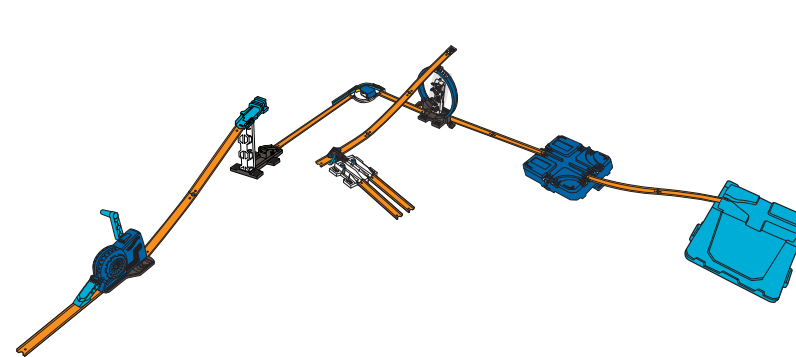

## BUILD 5

PAGE 24

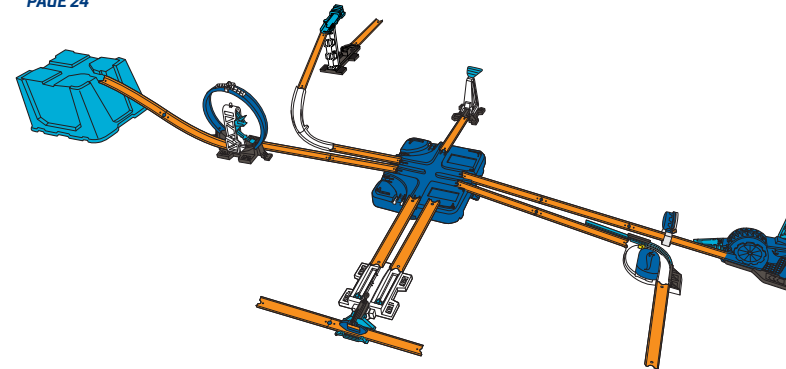

## BUILD 6

PAGE 26

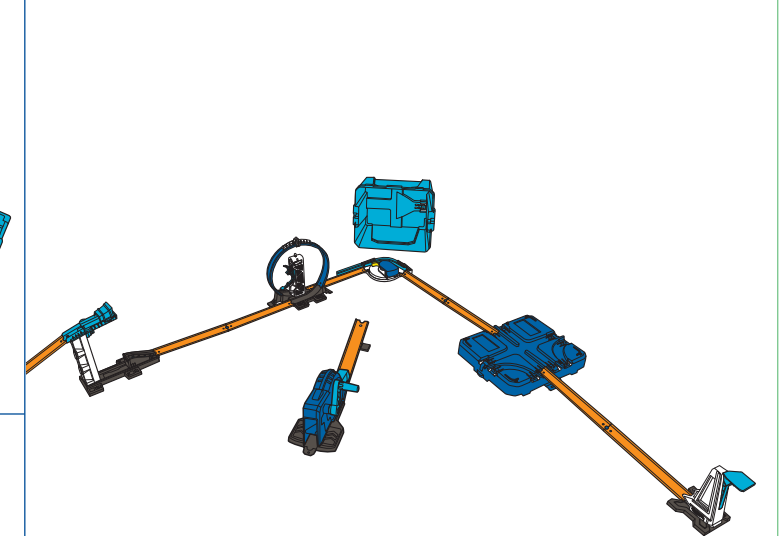

NOT FOR USE WITH SOME HOT WHEELS® VEHICLES.  
5 VEHICLES INCLUDED. ADDITIONAL VEHICLES SOLD SEPARATELY.

**NOTE: FOR BEST PERFORMANCE, PLAY ON LOW PILE CARPET OR HARD SURFACES.**



# BUILD 1

## HERE'S WHAT YOU NEED:

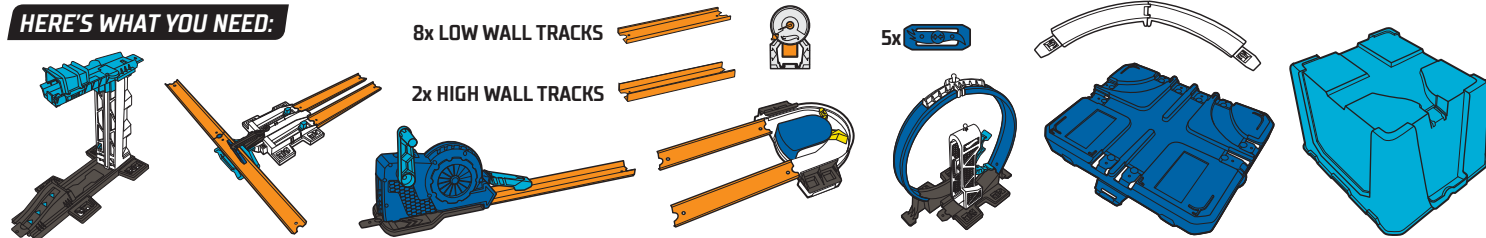

## ASSEMBLY:

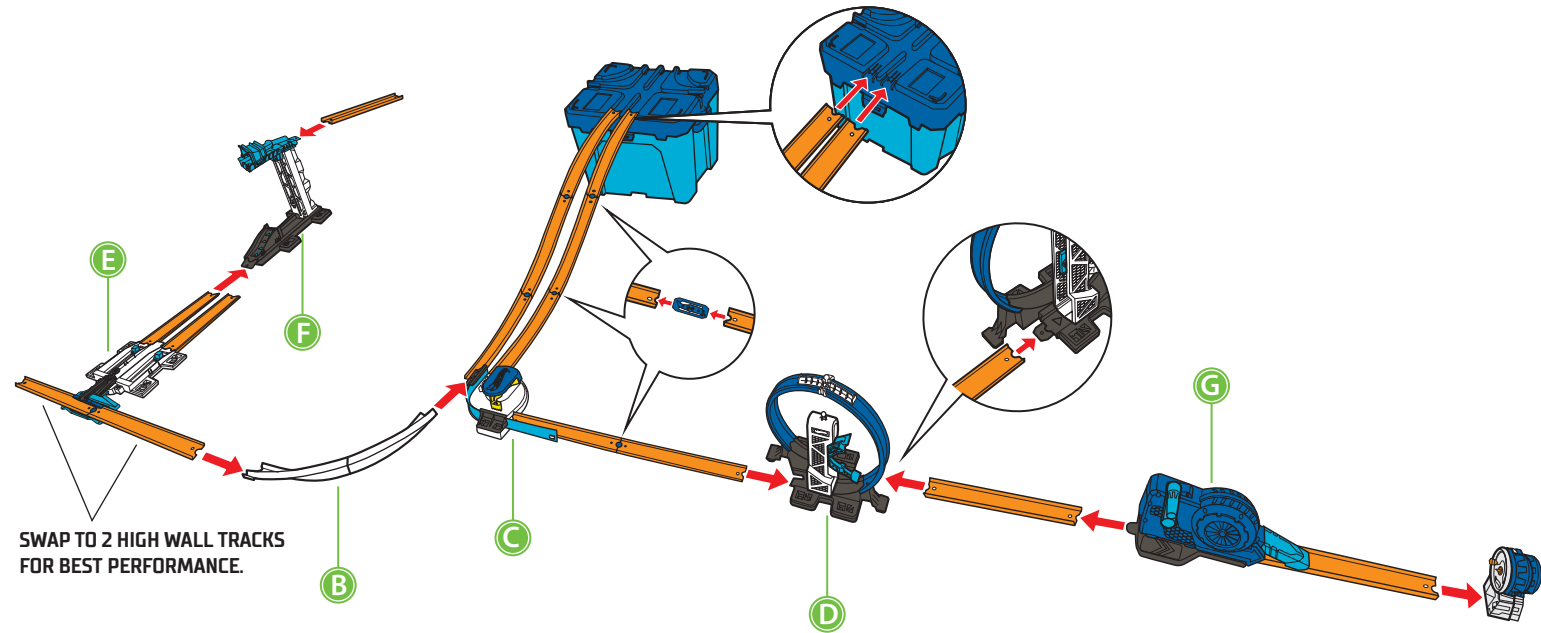

# NOW GRAB YOUR CAR AND GO!

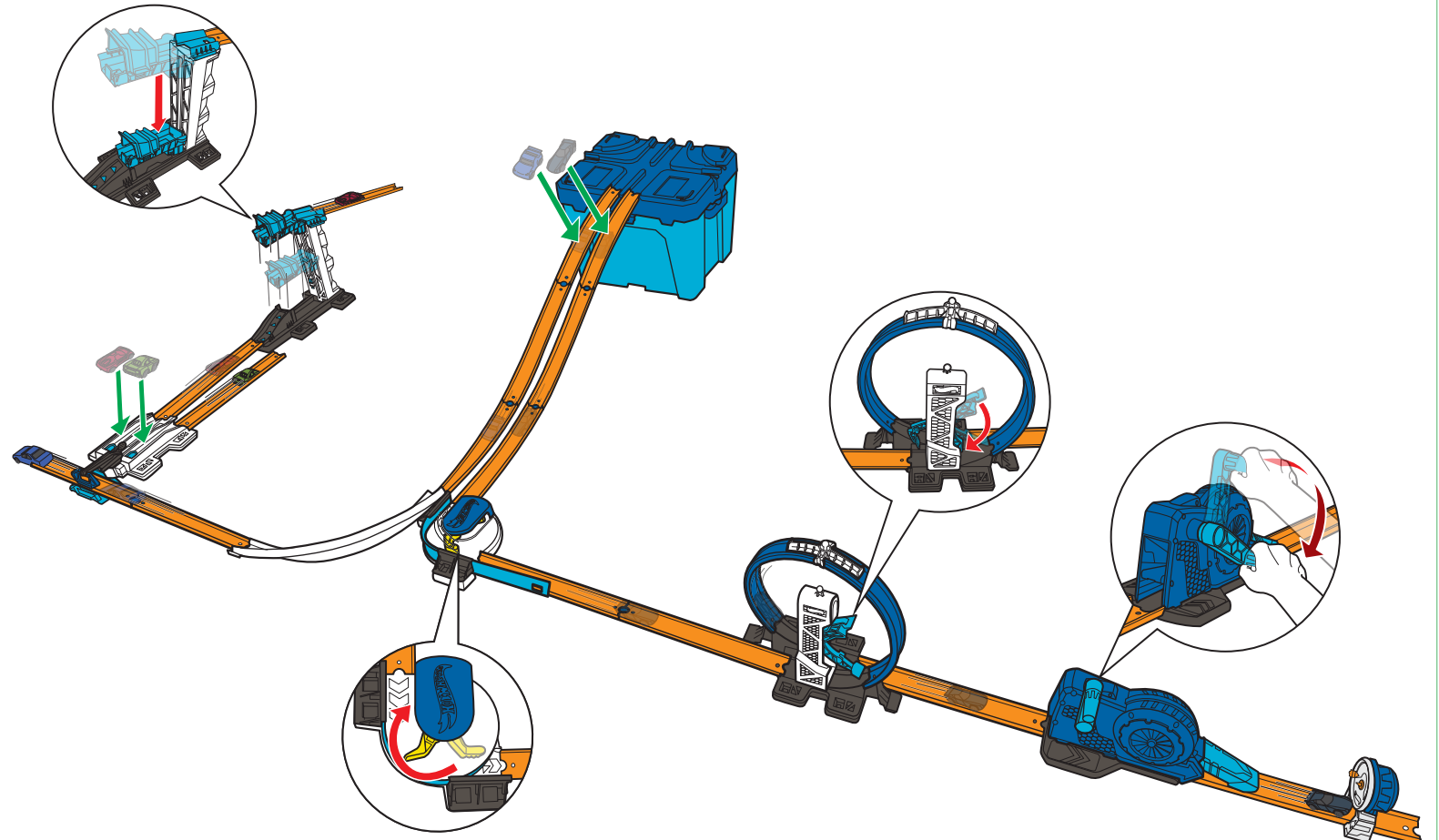



# BUILD 3

## HERE'S WHAT YOU NEED:

6x LOW WALL TRACKS

5x

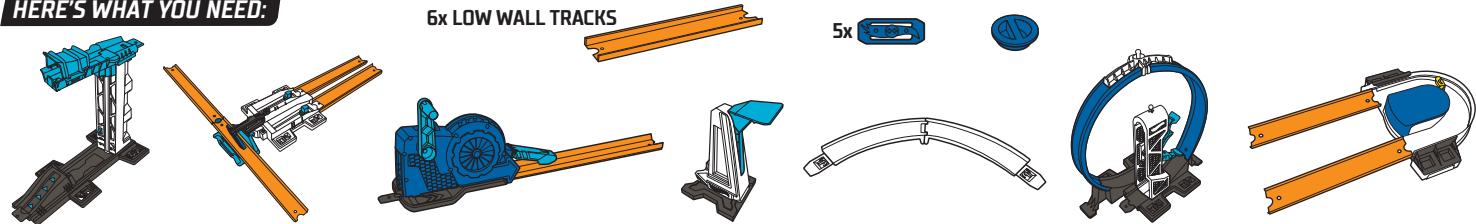

## ASSEMBLY:

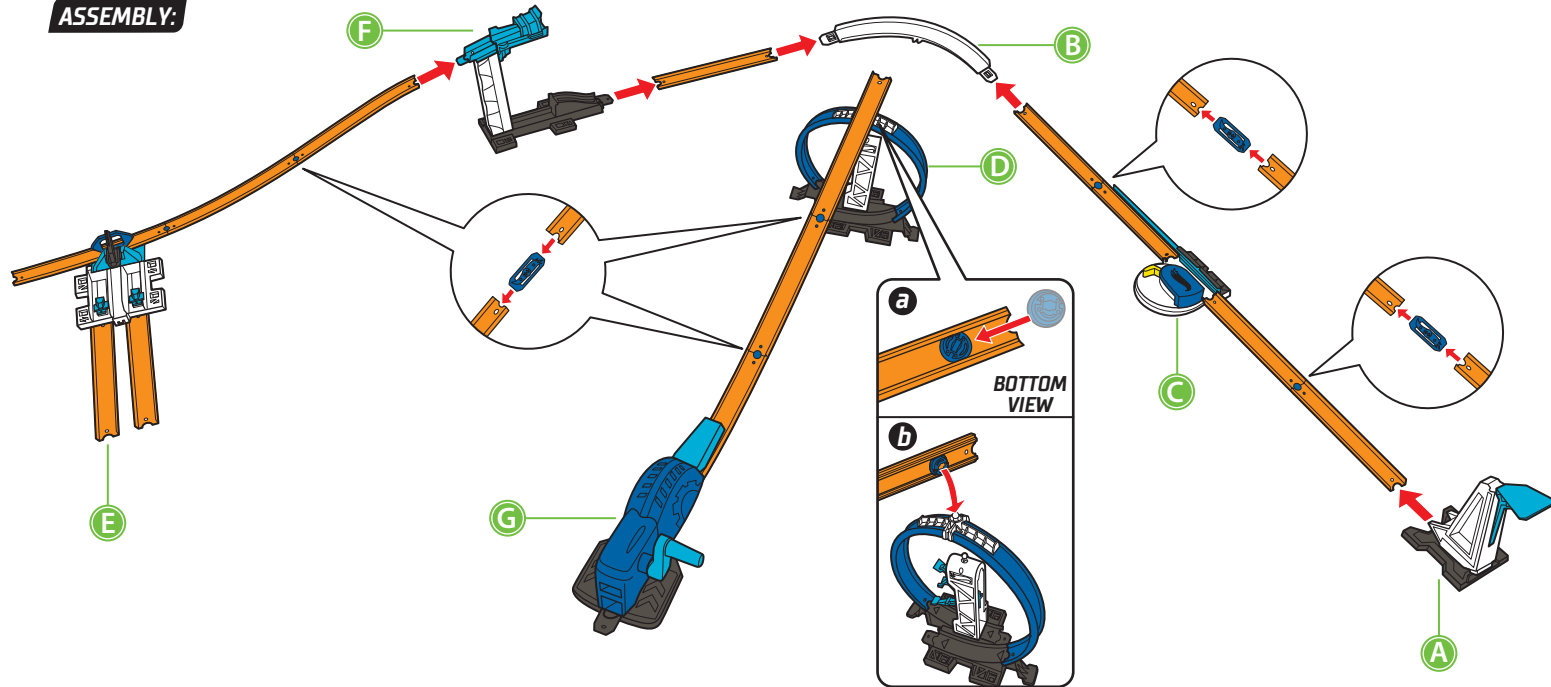

# NOW GRAB YOUR CAR AND GO!

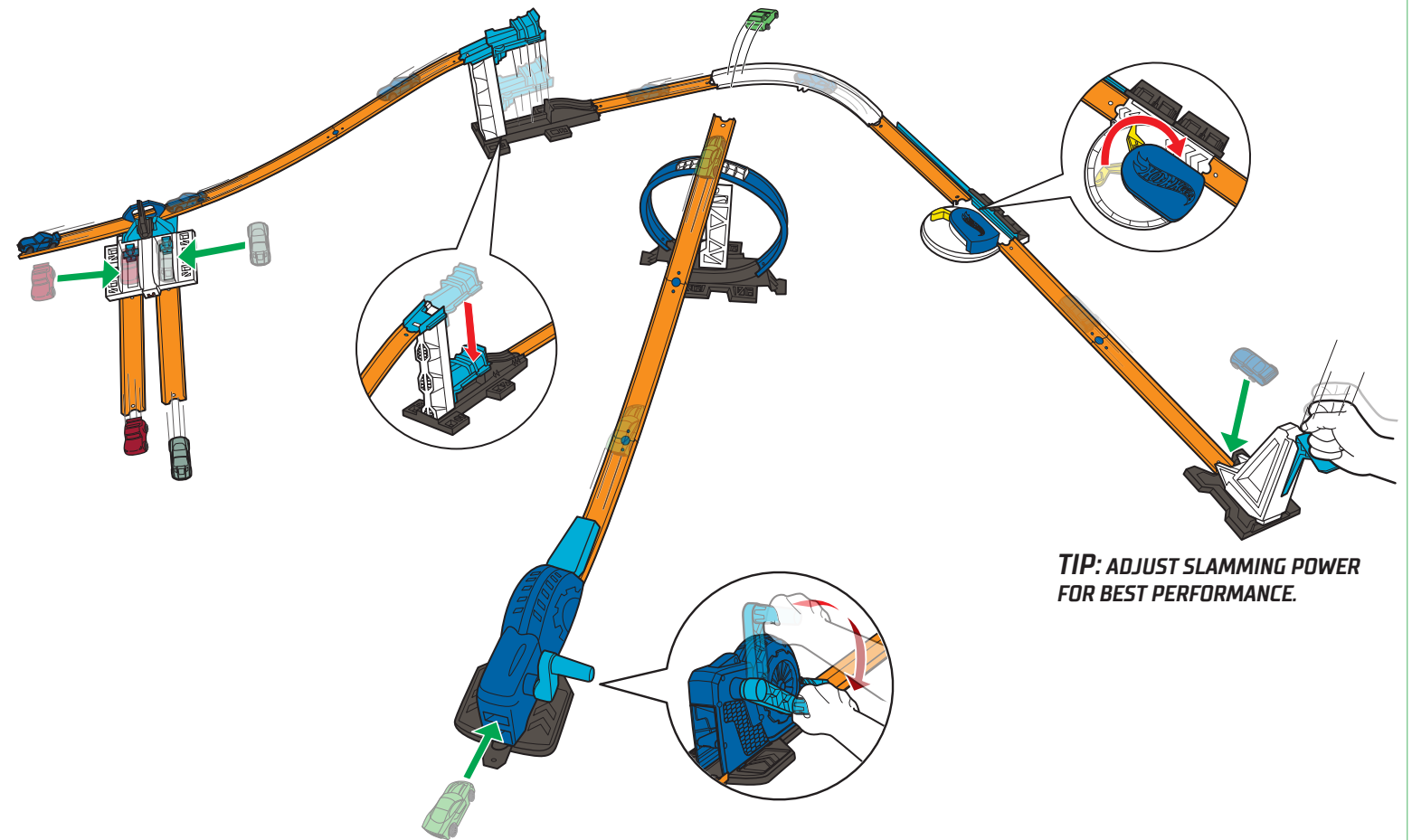

**TIP: ADJUST SLAMMING POWER FOR BEST PERFORMANCE.**

## BUILD 4

### HERE'S WHAT YOU NEED:

8x LOW WALL TRACKS

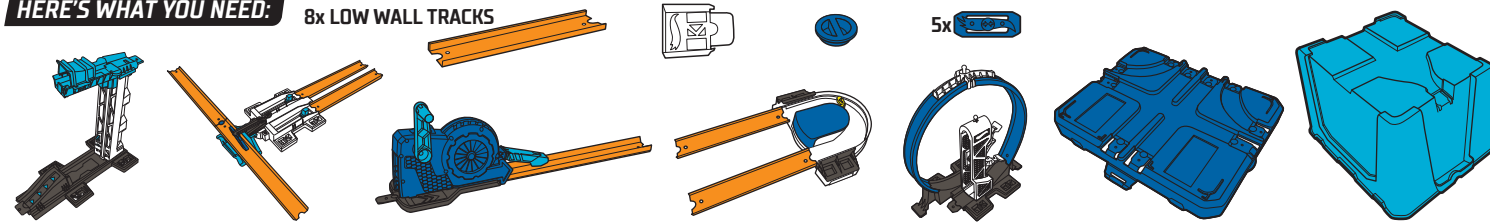

### ASSEMBLY:

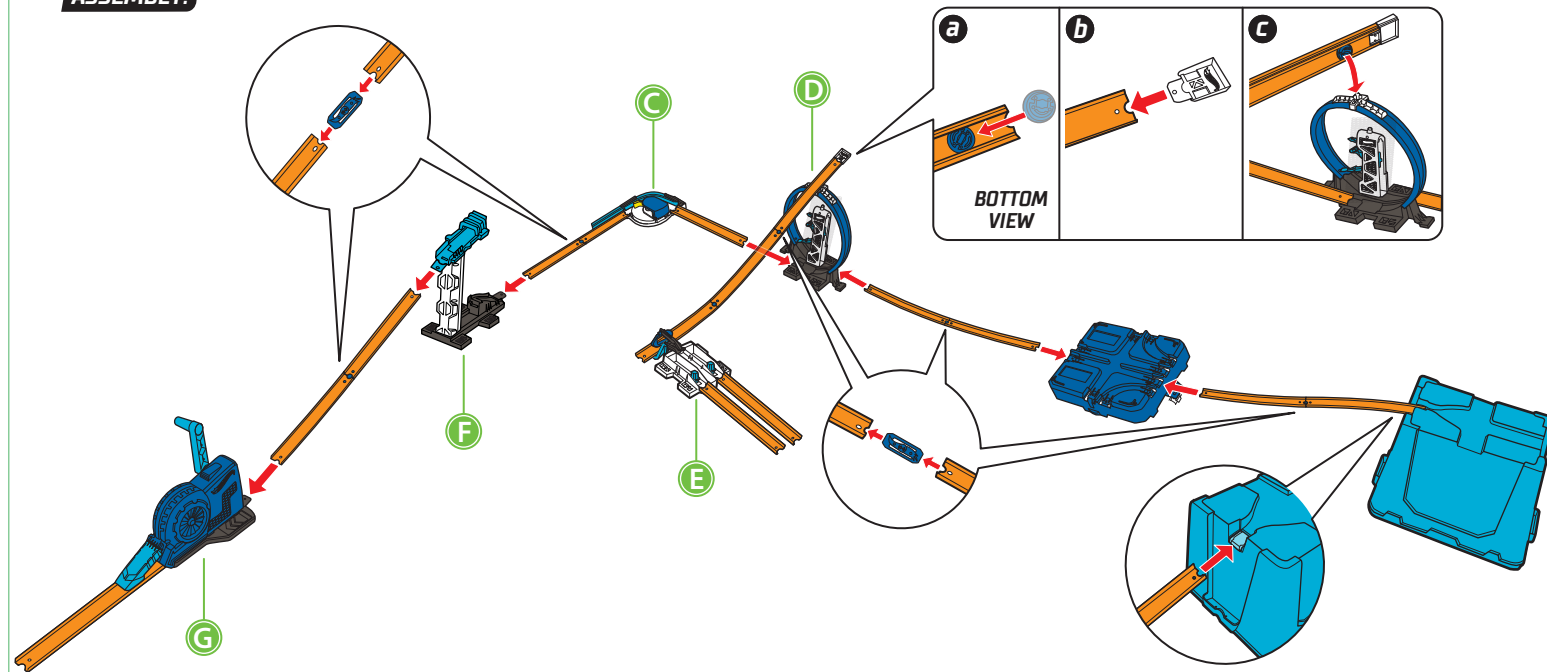

## NOW GRAB YOUR CAR AND GO!

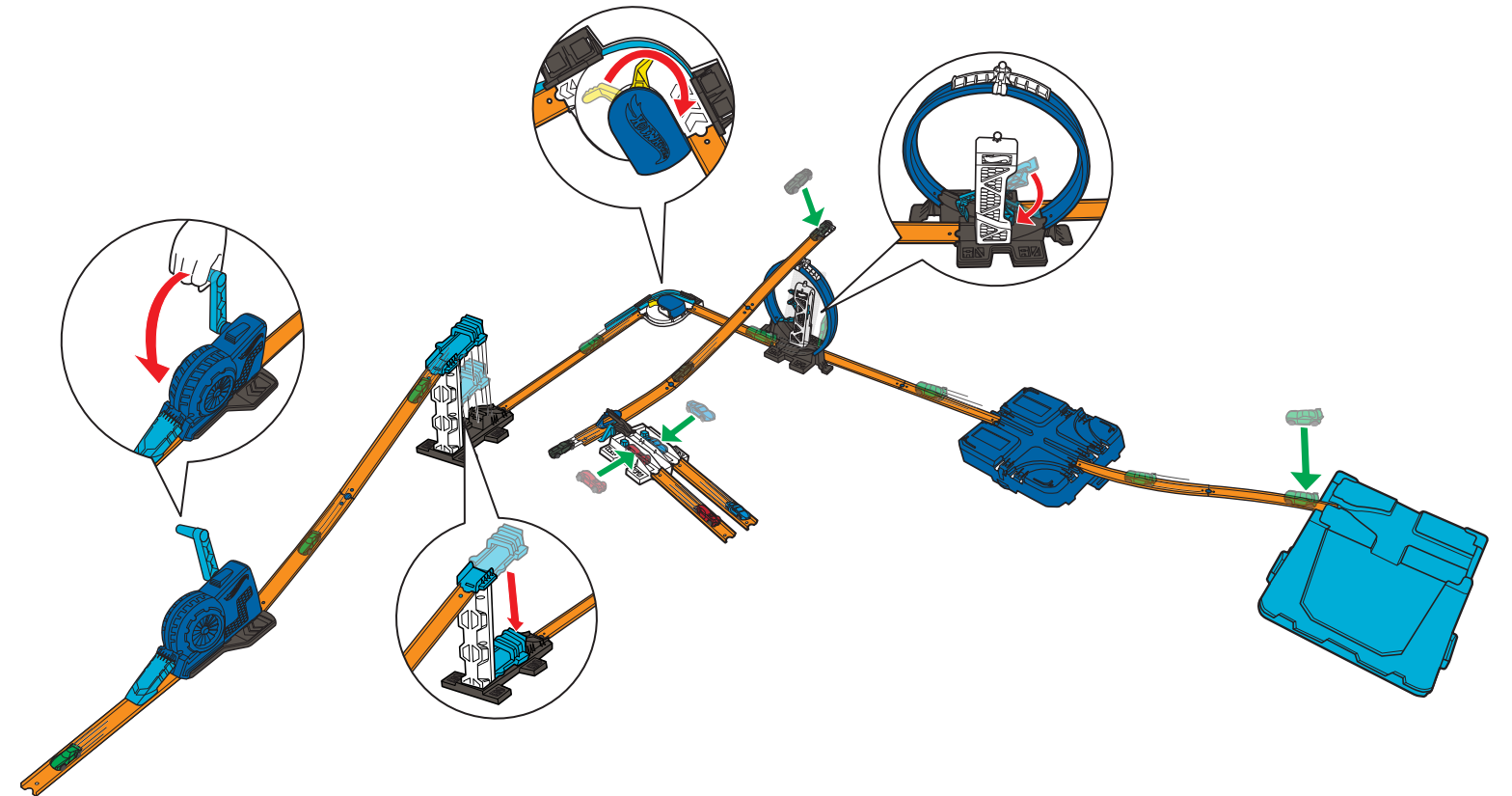



## BUILD 5

### HERE'S WHAT YOU NEED:

11x LOW WALL TRACKS

5x

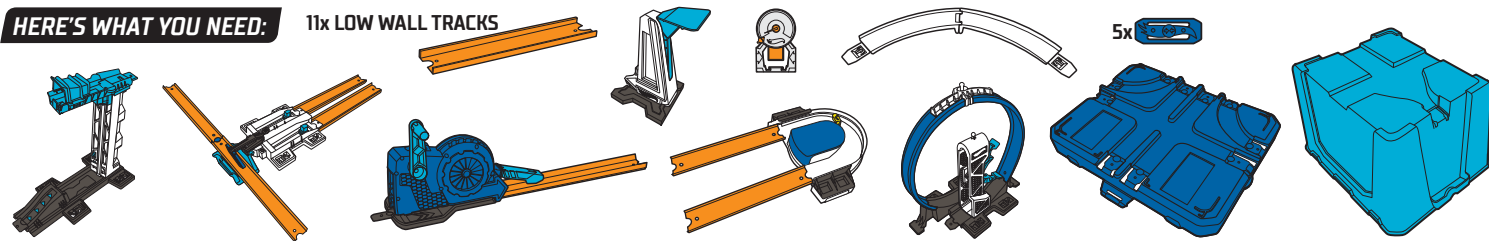

### ASSEMBLY:

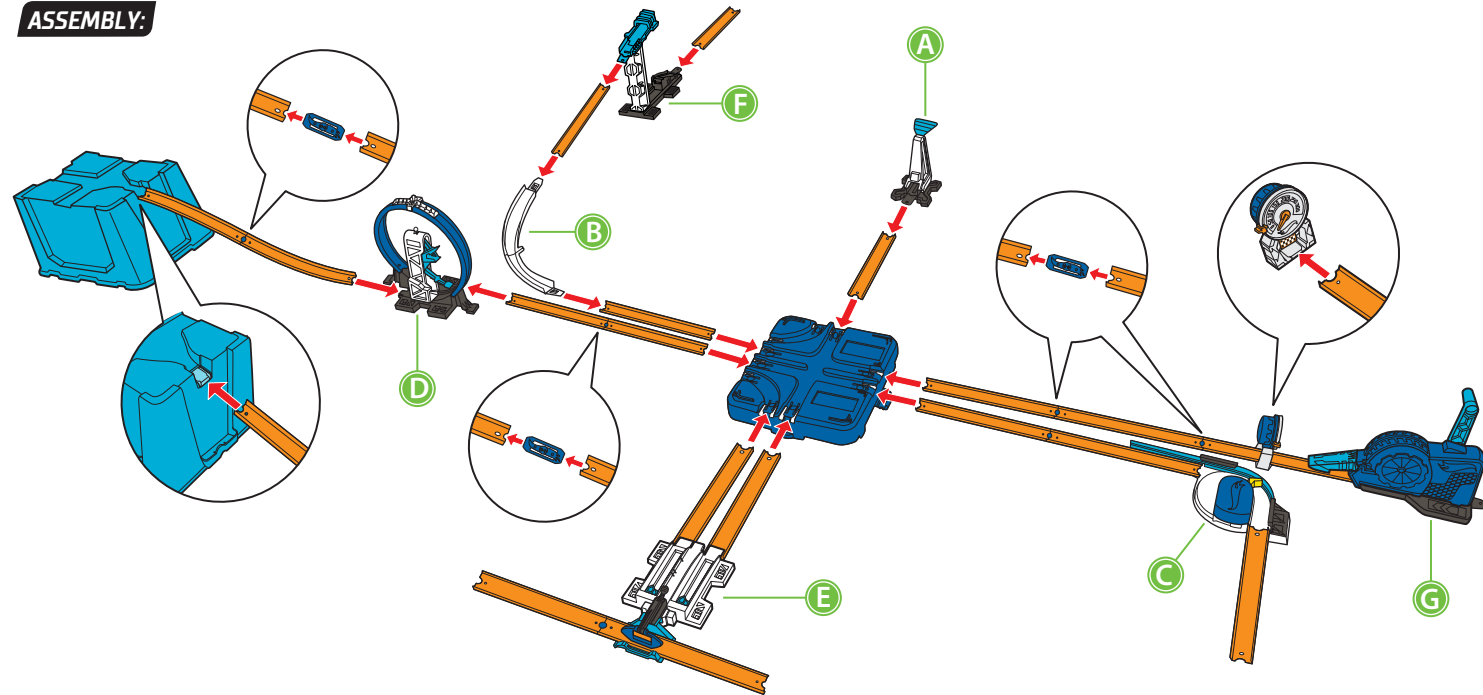

## NOW GRAB YOUR CAR AND GO!

**TIP: ADJUST SLAMMING POWER FOR BEST PERFORMANCE.**

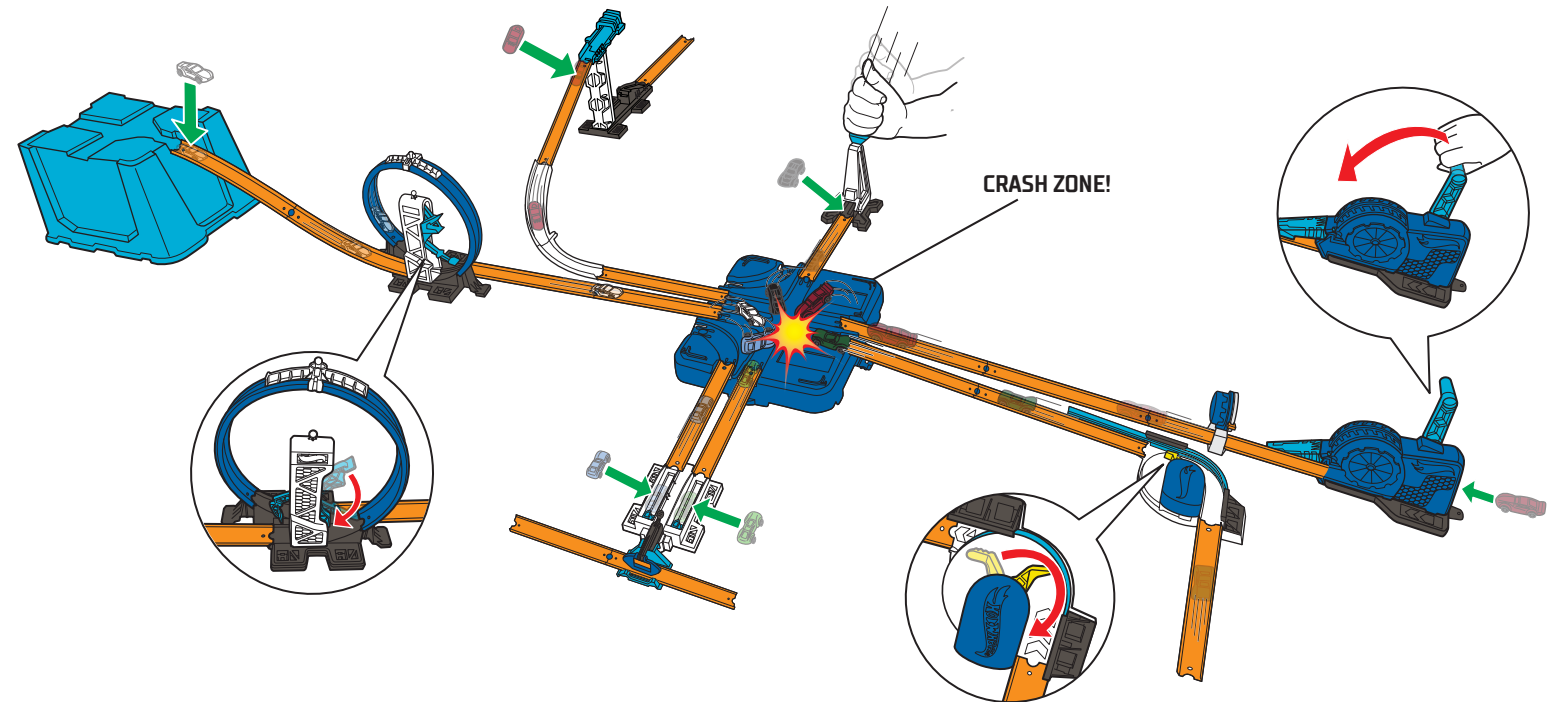

## BUILD 6

### HERE'S WHAT YOU NEED:

7x LOW WALL TRACKS

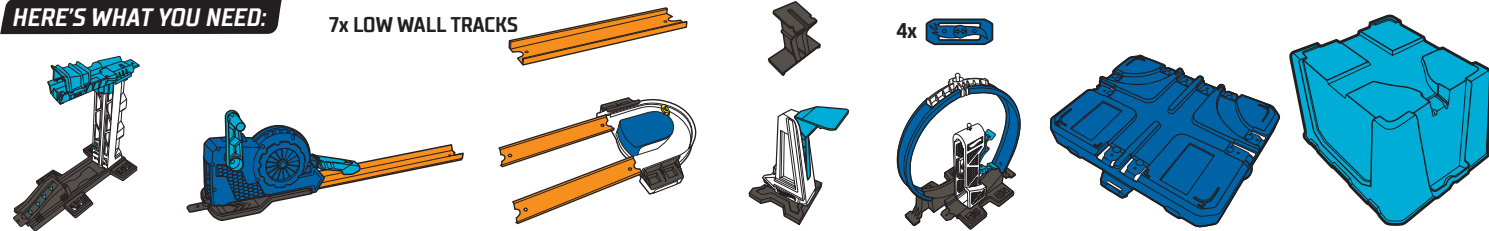

### ASSEMBLY:

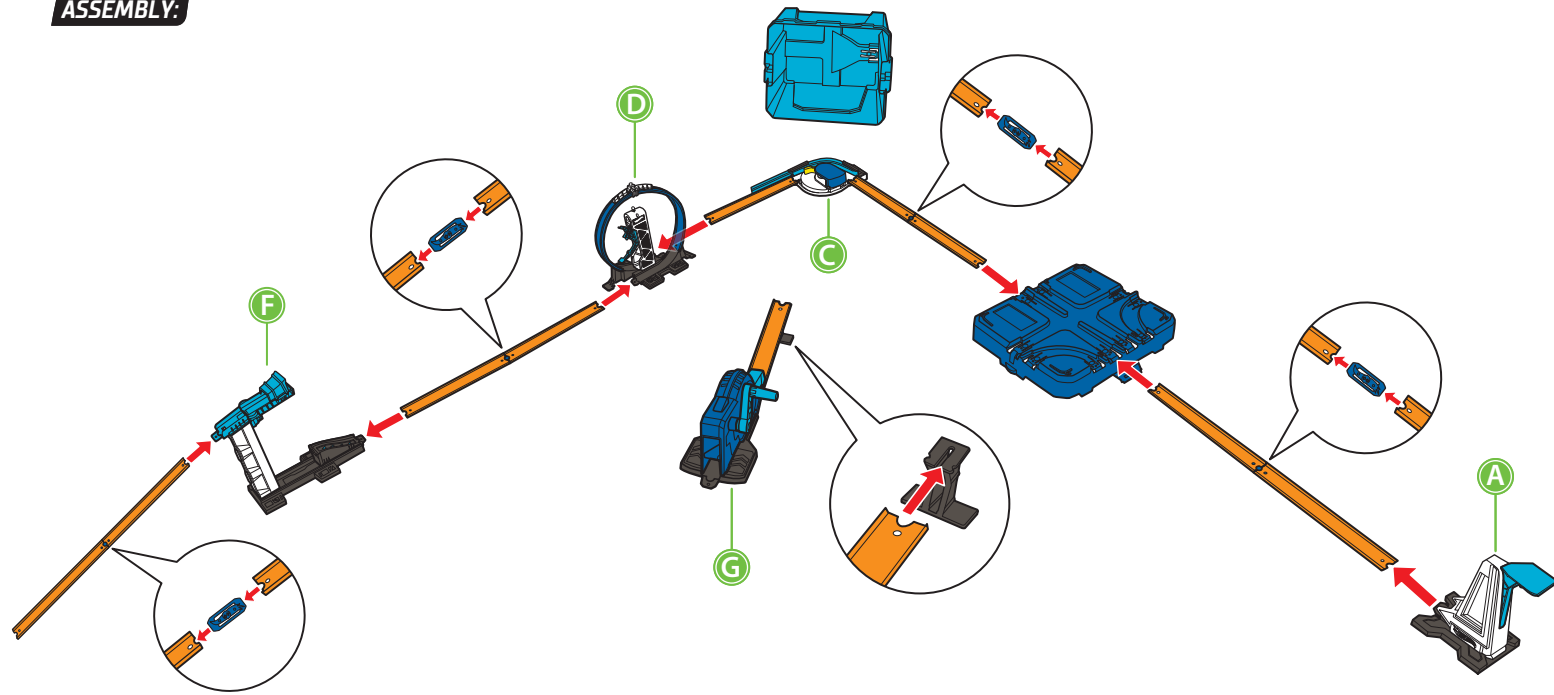

26

## NOW GRAB YOUR CAR AND GO!

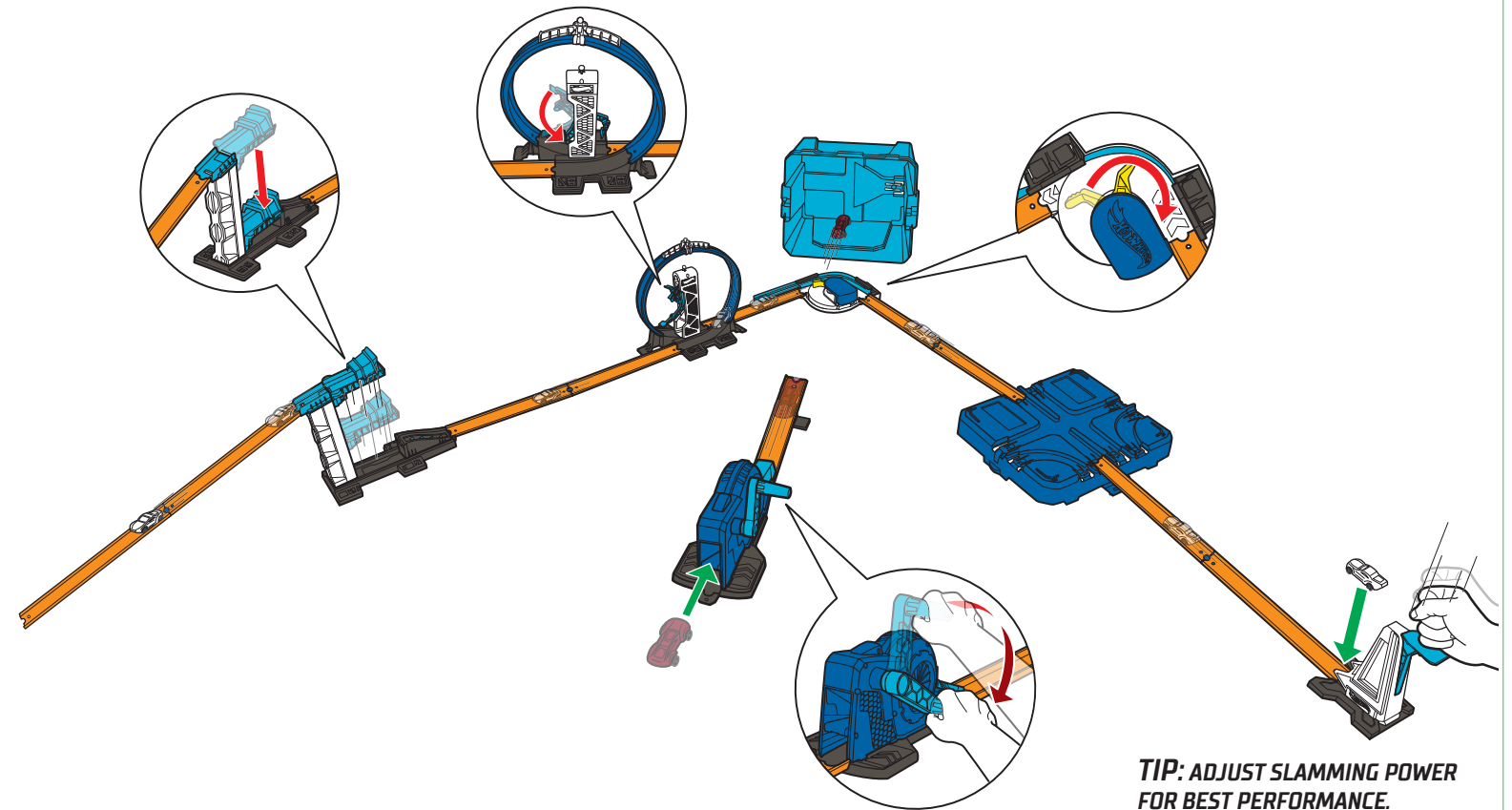

**TIP: ADJUST SLAMMING POWER FOR BEST PERFORMANCE.**

27