

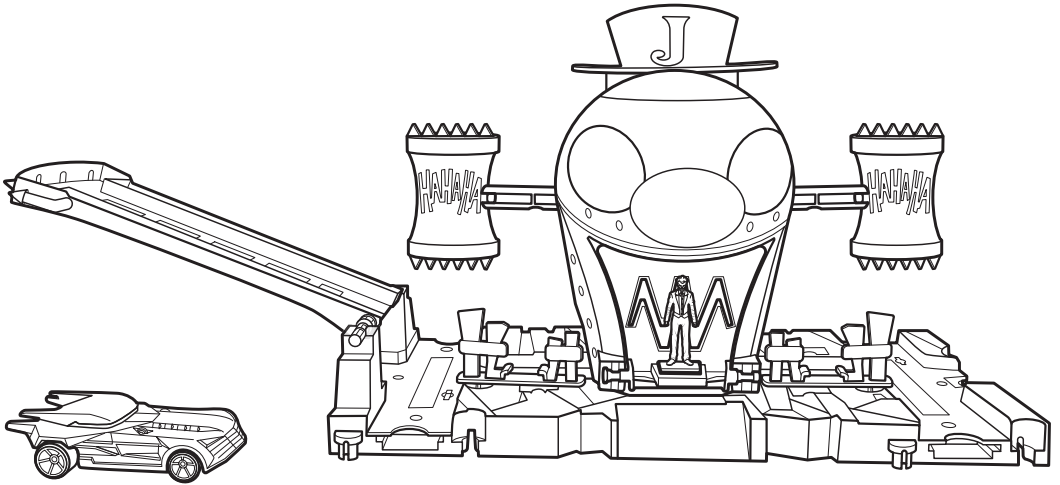

INSTRUCTIONS



THE JOKER™ FUNHOUSE



WARNING:
CHOKING HAZARD – Small parts.
Not for children under 3 years.

4-8



BATMAN and all related characters and elements © &™ DC Comics.
(s18)



ASST.GBW50
GBW51-0970

service.mattel.com

HOTWHEELS.COM

PLEASE KEEP THESE INSTRUCTIONS FOR FUTURE REFERENCE AS THEY CONTAIN IMPORTANT INFORMATION.

CONTENTS

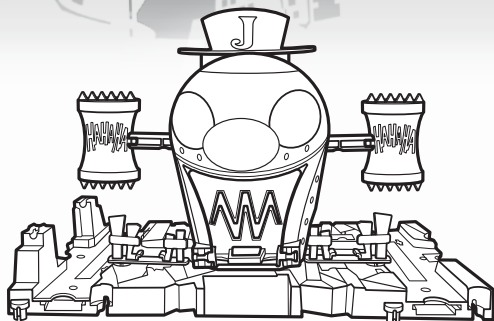
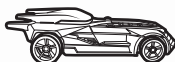
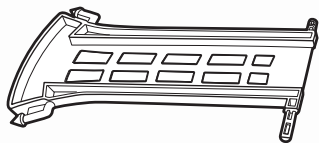

ASSEMBLY

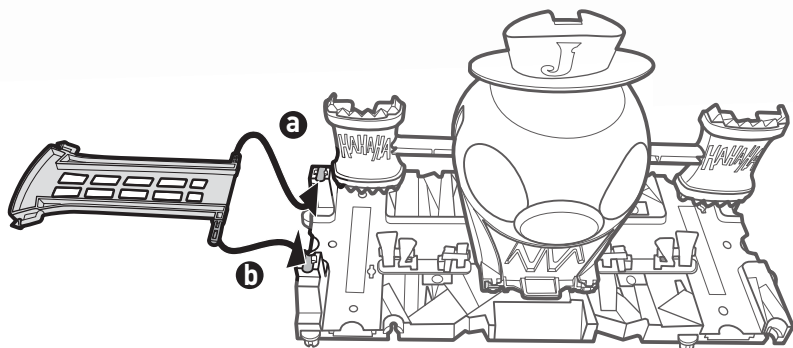

TO PLAY

1. OPEN THE JOKER™ FUNHOUSE GATE.

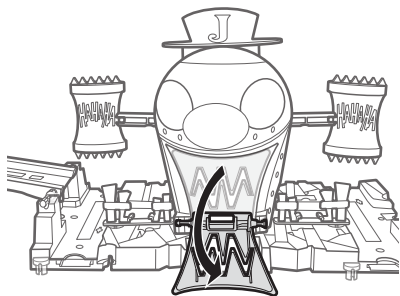

2. PRESS SWITCH TO ACTIVATE PRISON RAMP AND PLACE CAPTURED VEHICLE INSIDE.

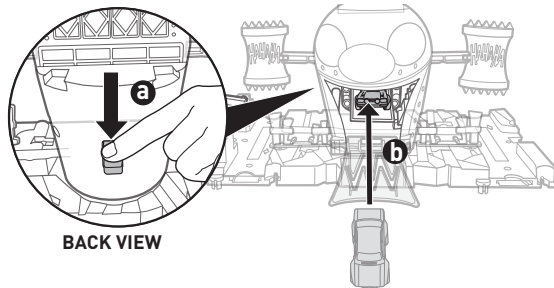

ONE VEHICLE INCLUDED. ADDITIONAL VEHICLES SOLD SEPARATELY.

TO PLAY (CONTD.)

3. CLOSE THE JOKER™ FUNHOUSE GATE.

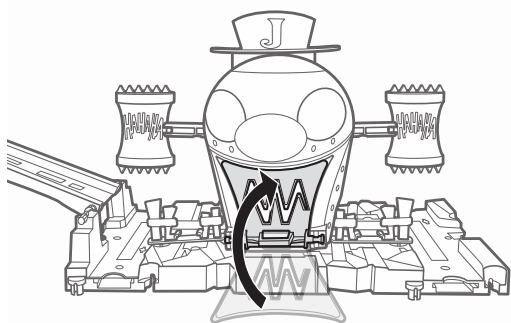

4. PLACE THE JOKER™ IN FRONT OF THE GATE.

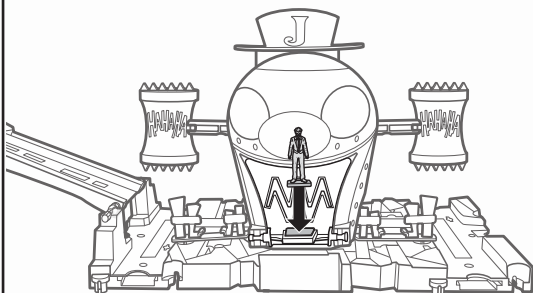

5. SWING THE JOKER'S MALLET.

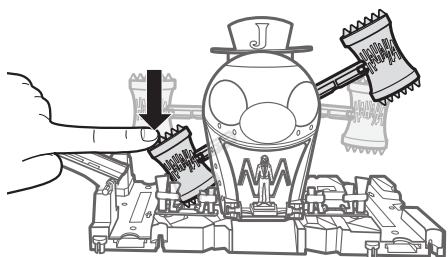

6. ROLL DOWN THE RAMP AND ENTER THE JOKER™ FUNHOUSE!

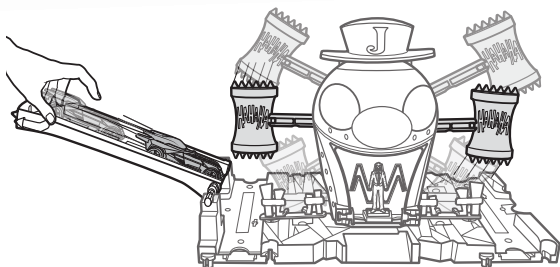

NOT FOR USE WITH SOME HOT WHEELS® VEHICLES.

7.

a. DON'T GET CRUSHED BY THE JOKER'S MALLET!

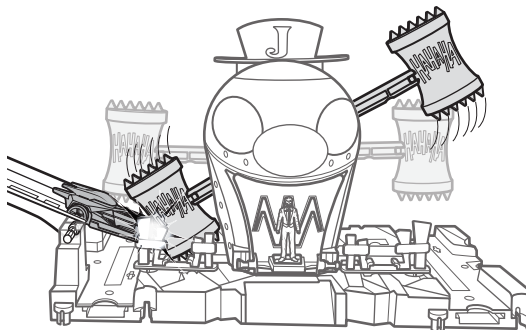

b. COMPLETE THE JOKER™ FUNHOUSE TO FREE YOUR FRIENDS!

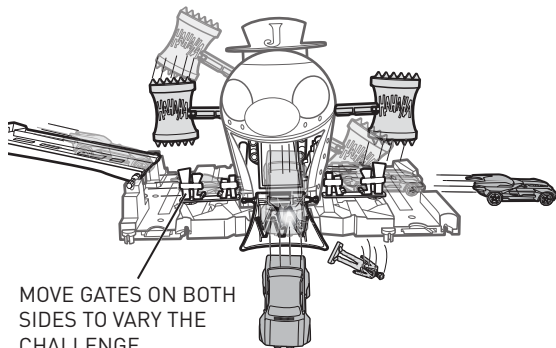

MOVE GATES ON BOTH SIDES TO VARY THE CHALLENGE.

MORE WAYS TO PLAY

1. FIGURE CAN ALSO BE ATTACHED TO ANY OF THESE SLOTS.

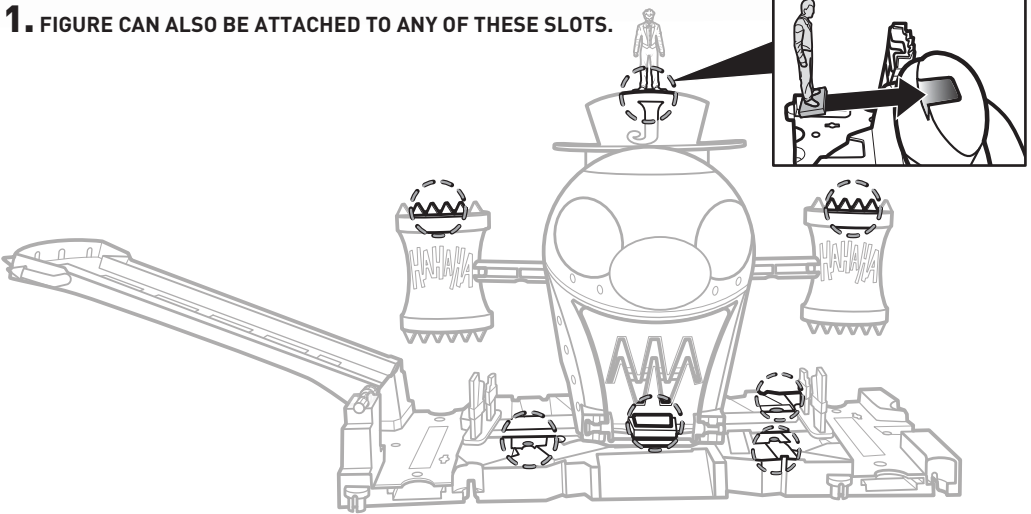

2. COLLECT OTHER SETS TO BUILD YOUR OWN HOT WHEELS™ CITY!

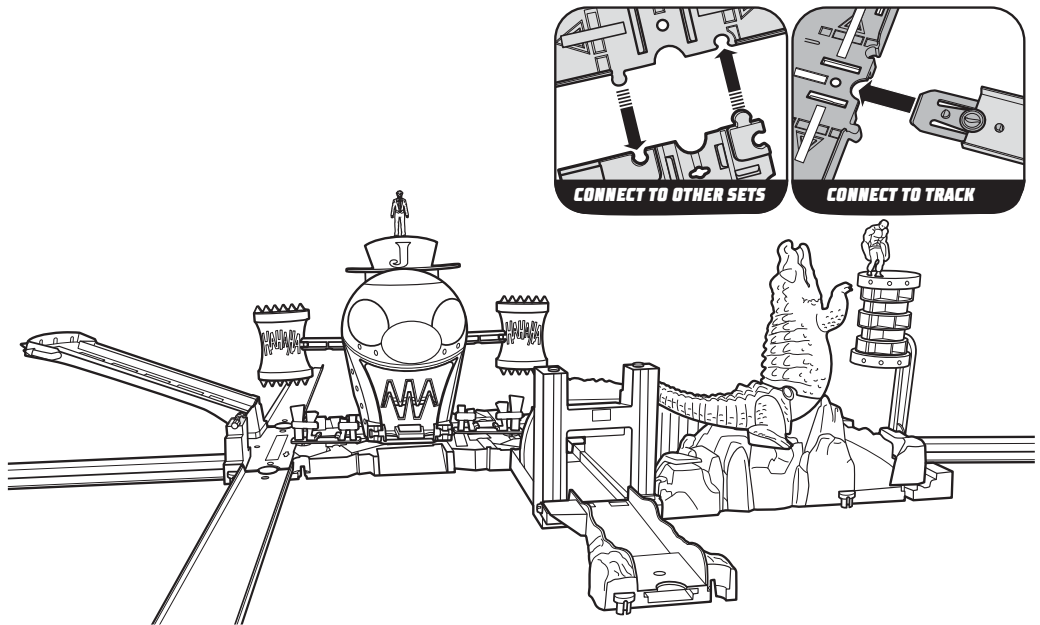

OTHER HOT WHEELS® TRACKS AND SETS SOLD SEPARATELY.

©2018 Mattel. ® and ™ designate U.S. trademarks of Mattel, except as noted. Mattel, Inc., 636 Girard Avenue, East Aurora, NY 14052, U.S.A. Consumer Services 1-800-524-8697. Mattel U.K. Ltd., Vanwall Business Park, Maidenhead SL6 4UB. Helpline 01628 500303. Mattel Australia Pty., Ltd., Richmond, Victoria. 3121. Consumer Advisory Service - 1300 135 312. Mattel South Africa (PTY) LTD, Office 102 I3, 30 Melrose Boulevard, Johannesburg 2196. Mattel East Asia Ltd., Room 503-09, North Tower, World Finance Centre, Harbour City, Tsimshatsui, HK, China. Tel.: (852) 3185-6500. Diimport & Diedarkan Oleh: Mattel Southeast Asia Pte. Ltd., No 19-1, Tower 3 Avenue 7, Bangsar South City, No 8, Jalan Kerinchi, 59200 Kuala Lumpur, Malaysia. Tel: 03-33419052.