

ADVERTISEMENT · PUBLICIDAD · INFORMATION PUBLICITAIRE · PUBLICIDADE



WWW.HOTWHEELS.COM/TRACKBUILDER

EACH SOLD SEPARATELY, SUBJECT TO AVAILABILITY. COLORS AND DECORATIONS MAY VARY. • SE VENDEN POR SEPARADO Y ESTÁN SUJETOS A DISPONIBILIDAD. LOS COLORES Y DECORACIÓN PUEDEN VARIAR DE LOS MOSTRADOS. • TOUS VENDUS SÉPARÉMENT, SELON LA DISPONIBILITÉ. LES COULEURS ET LES MOTIFS PEUVENT VARIER. • VENDIDOS SEPARADAMENTE, SUJETOS A DISPONIBILIDADE. AS CORES E AS DECORAÇÕES PODEM VARIAR.

©2018 Mattel, Mattel, Inc., 636 Girard Avenue, East Aurora, NY 14052, U.S.A. Consumer Services 1-800-524-8697. Mattel Canada Inc., Mississauga, Ontario L5R 3W2. You may call us free at / Composez sans frais le 1-800-524-8697. Mattel Australia Pty., Ltd., Richmond, Victoria, 3121 Consumer Advisory Service - 1300 135 312. Mattel East Asia Ltd., Room 503-09, North Tower, World Finance Centre, Harbour City, Tsimshatsui, HK, China. Tel.: (852) 3185-6500. Diimport & Diedarkan Oleh: Mattel Southeast Asia Pte. Ltd., No 19-1, Tower 3 Avenue 7, Bangsar South City, No 8, Jalan Kerinchi, 59200 Kuala Lumpur, Malaysia. Tel: 03-33419052. Mattel U.K. Ltd., Vanwall Business Park, Maidenhead SL6 4UB. Importado y distribuido por Mattel de México, S.A. de C.V., Miguel de Cervantes Saavedra No. 193, Pisos 10 y 11, Col. Granada, Delegación Miguel Hidalgo, C.P. 11520, México, Ciudad de México. R.F.C. MME-920701-NB3. Tels.: 59-05-51-00 Ext. 5206 ó 01-800-463-59-89. Mattel Chile, S.A., Avenida Américo Vespucio 501-B, Quilicura, Santiago, Tel.: 1230-020-6213. Servicio al consumidor Venezuela: Tel.: 0-800-100-9123. Mattel Argentina, S.A., Av. Libertador 1000, Piso 11 - Oficinas 109 y 111, Vicente López - Prov. Buenos Aires. Tel.: 0800-666-3373. Mattel Colombia, S.A., Calle 123#7-07 P.5, Bogotá, Tel.: 01800-710-2069. Mattel Perú, S.A., Av. Juan de Arona # 151, Centro Empresarial Juan de Arona, Torre C, Piso 7, Oficina 704, San Isidro, Lima 27, Perú. RUC: 20425853865. Reg. Importador: 02350-12-JUE-DIGESA, Tel.: 0800-54744. E-mail Latinoamérica: Servicio.Clientes@Mattel.com. Distribuido por: Mattel do Brasil Ltda - CNPJ: 54.558.002/0001-20 - Rua Verbo Divino, 1488 - 2º Andar - 04719-904 - Chácara Santo Antônio - São Paulo - SP - Brasil. Serviço de Atendimento ao Consumidor: fone 0800-550780. E-mail: sac@mattel.com. Mattel France, Parc de la Cerisaie, 1/3/5 allée des Fleurs, 94260 Fresnes Cedex. N° Cristal 0969 36 99 99 (Numéro non surtaxé) ou www.lesjouetsmattel.fr. Mattel España, S.A., Aribau 200, 08036 Barcelona. cservice.spain@mattel.com Tel: 902203010 http://www.service.mattel.com/es. Mattel Portugal Lda., Edifício Amoreiras Square, Rua Carlos Alberto da Mota Pinto nº 17 - 3º A, 1070-313 Lisboa. Tel. Número Verde: 800 10 10 71 - consumidor@mattel.com. Mattel South Africa (PTY) LTD, Office 102 13, 30 Melrose Boulevard, Johannesburg 2196.

HOT WHEELS
TRACK BUILDER
SYSTEM™

BUILDER'S GUIDE
GUÍA DEL CREADOR DE PISTAS
GUIDE DE CONSTRUCTION
GUIA DE MONTAGEM

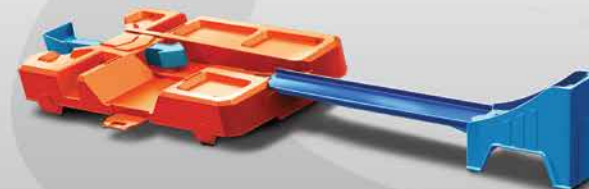

ASST.FLK89
GCF91-4B71
1101516965-4LB

service.mattel.com
HOTWHEELS.COM

PLEASE KEEP THESE INSTRUCTIONS FOR FUTURE REFERENCE AS THEY CONTAIN IMPORTANT INFORMATION. • LEE Y GUARDA ESTAS INSTRUCCIONES PARA FUTURA REFERENCIA, YA QUE CONTIENEN INFORMACIÓN DE IMPORTANCIA DE ESTE PRODUCTO. • CONSERVER CE MODE D'EMPLOI POUR S'Y RÉFÉRER AU BESOIN CAR IL CONTIENT DES INFORMATIONS IMPORTANTES. • POR FAVOR, GUARDE ESTAS INSTRUÇÕES PARA FUTURA REFERÊNCIA, POIS CONTÉM INFORMAÇÕES IMPORTANTES.

6-12

The world of Track Builder offers endless possibilities and hours of fun where the formula is: **CREATE + EXPERIMENT + REPEAT.**
 Sigue esta fórmula para posibilidades ilimitadas y horas de diversión con el mundo de Track Builder: **CREA + EXPERIMENTA + REPITE.**
 Suivez cette formule pour des possibilités de jeu infinies et des heures de plaisir dans l'univers Track Builder : **CRÉER + ESSAYER + RECOMMENCER.**
 O mundo de Track Builder traz infinitas possibilidades e horas de diversão onde a fórmula é: **CRIAR + EXPERIMENTAR + REPETIR.**

HERE'S WHAT YOU GET: • CONTENIDO: • VOICI LE CONTENU : • ITENS INCLUÍDOS

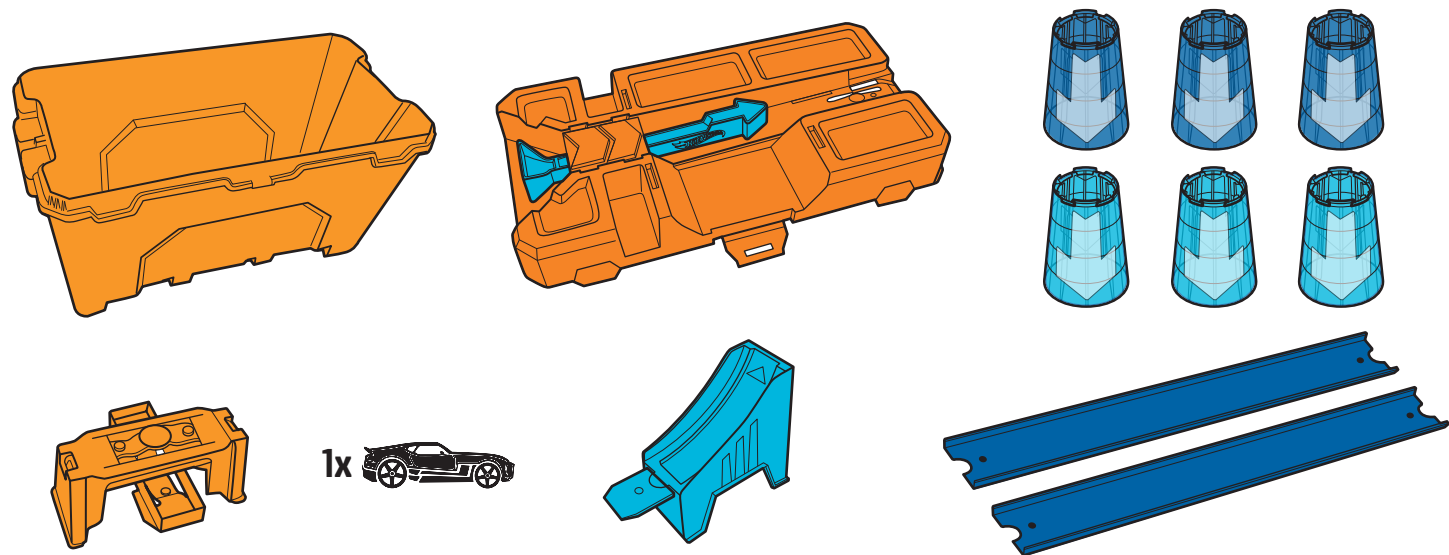

PARENTS: CHECK OUT THE HOT WHEELS® YOUTUBE CHANNEL FOR EPIC TRACK IDEAS!
 PADRES: ¡VISITA EL CANAL DE HOT WHEELS EN YOUTUBE PARA VER IDEAS INCREÍBLES DE PISTAS!
 PARENTS : POUR DES IDÉES DE PISTE, VISITEZ LA CHAÎNE HOT WHEELS SUR YOUTUBE!
 PAIS: CONFIRA O CANAL HOT WHEELS NO YOUTUBE PARA MAIS IDEIAS!

WWW.YOUTUBE.COM/HOTWHEELS



**CHOOSE ONE TO SET UP FIRST! • ¡ESCOGE LA QUE QUIERAS CONSTRUIR PRIMERO!
 COMMENCEZ PAR CHOISIR UNE CONFIGURATION! • ESCOLHA UMA PARA MONTAR PRIMEIRO!**

CONFIGURATION
 CONFIGURACIÓN
 CONFIGURAÇÃO **1**

PAGE 4 • PÁGINA 4

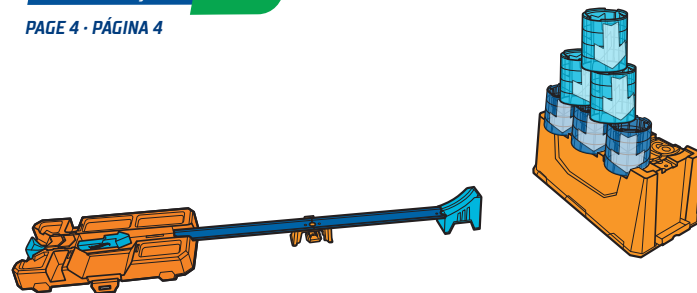

CONFIGURATION
 CONFIGURACIÓN
 CONFIGURAÇÃO **2**

PAGE 7 • PÁGINA 7

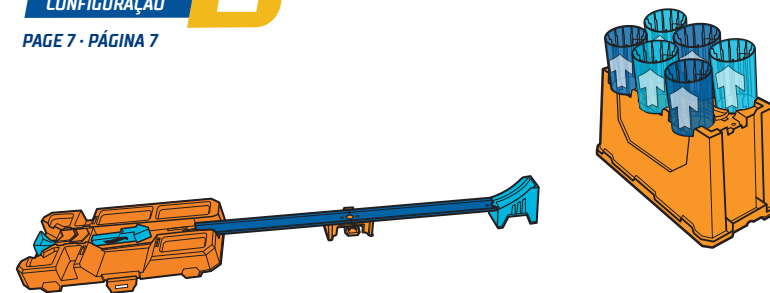

CONFIGURATION
 CONFIGURACIÓN
 CONFIGURAÇÃO **3**

PAGE 10 • PÁGINA 10

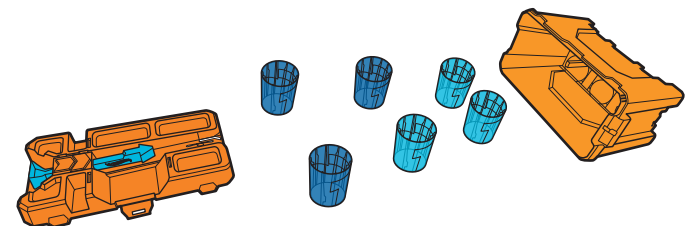

CONFIGURATION
 CONFIGURACIÓN
 CONFIGURAÇÃO **4**

PAGE 12 • PÁGINA 12

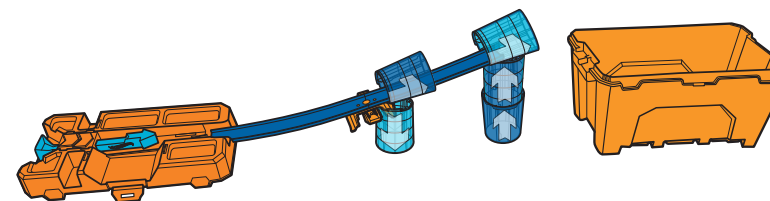

COLORS AND DECORATIONS MAY VARY. NOT FOR USE WITH SOME HOT WHEELS® VEHICLES. ONE VEHICLE INCLUDED. ADDITIONAL VEHICLES SOLD SEPARATELY. • LOS COLORES Y DECORACIÓN PUEDEN VARIAR DE LOS MOSTRADOS. NO COMPATIBLE CON ALGUNOS VEHÍCULOS HOT WHEELS. INCLUYE UN VEHÍCULO. LOS VEHÍCULOS ADICIONALES SE VENDEN POR SEPARADO. • LES COULEURS ET LES MOTIFS PEUVENT VARIER. NON COMPATIBLE AVEC CERTAINS VÉHICULES HOT WHEELS. CONTIENT UN VÉHICULE. AUTRES VÉHICULES VENDUS SÉPARÉMENT. • AS CORES E AS DECORAÇÕES PODEM VARIAR. NÃO É COMPATÍVEL COM ALGUNS VEÍCULOS HOT WHEELS. UM VEÍCULO INCLUÍDO. VEÍCULOS ADICIONAIS VENDIDOS SEPARADAMENTE.

CONFIGURATION 1 • CONFIGURACIÓN 1 • CONFIGURAÇÃO 1

PARTS YOU NEED: • PIEZAS NECESARIAS: • PIÈCES NÉCESSAIRES: • PEÇAS QUE VOCÊ PRECISA:

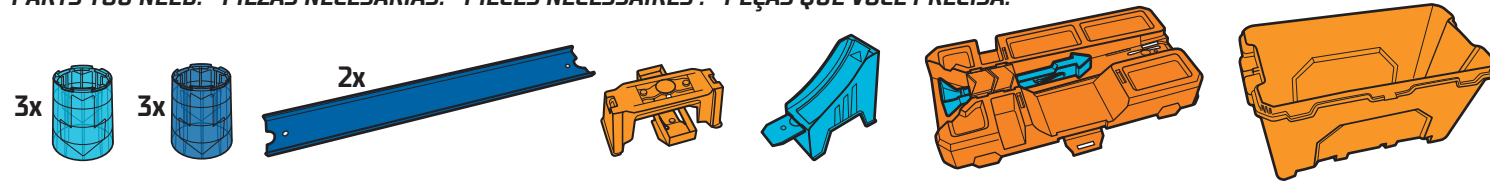

1

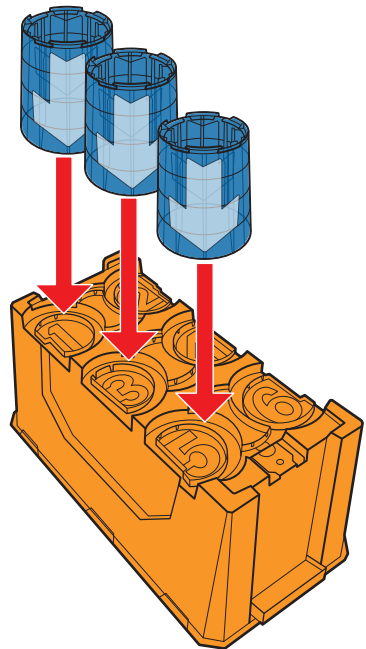

2

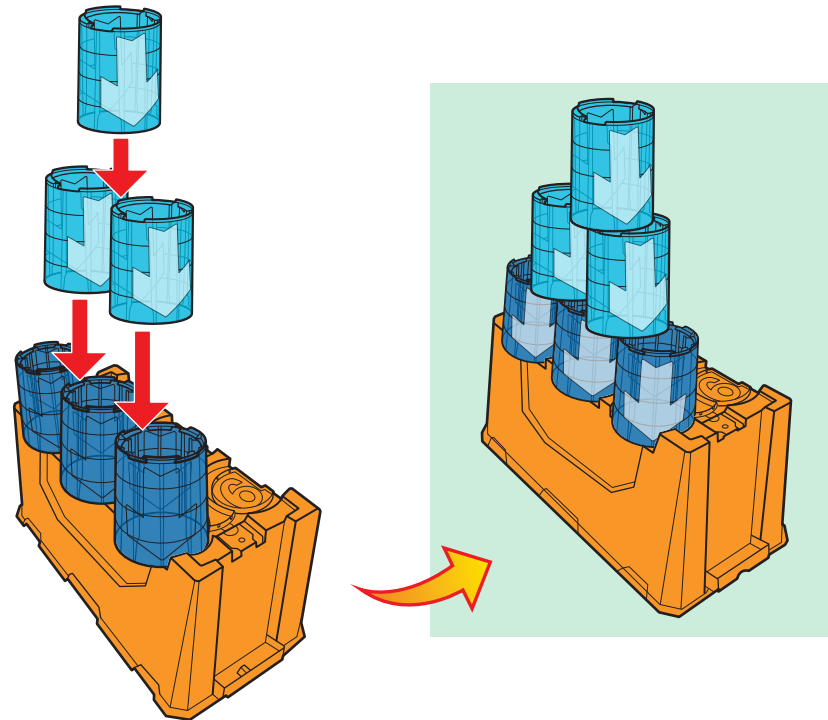

4

3

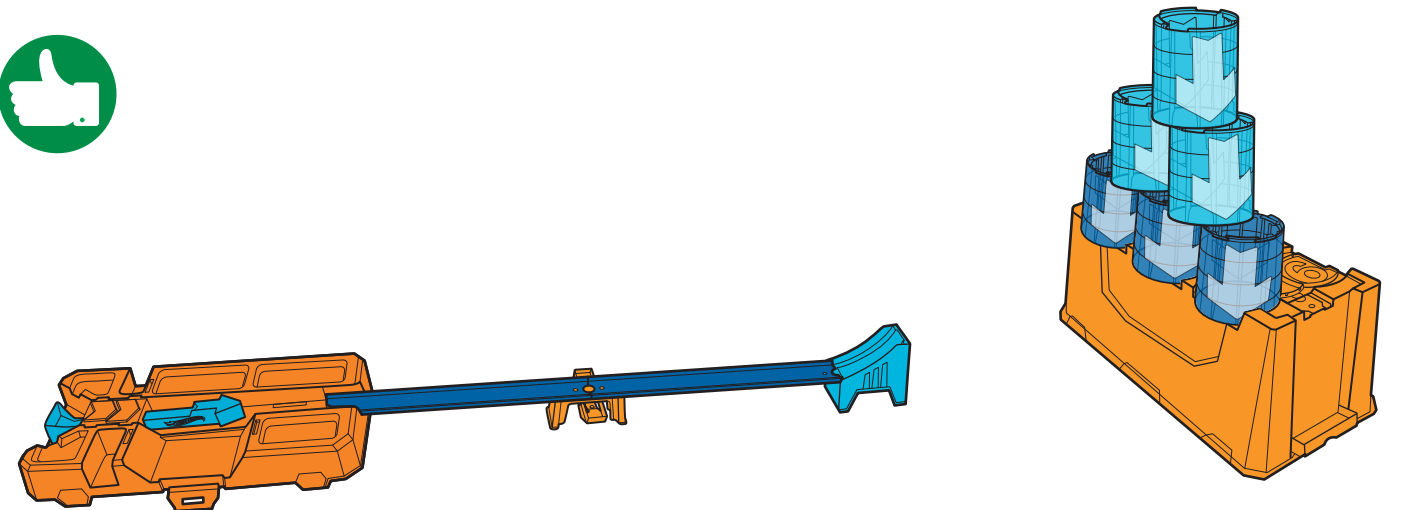
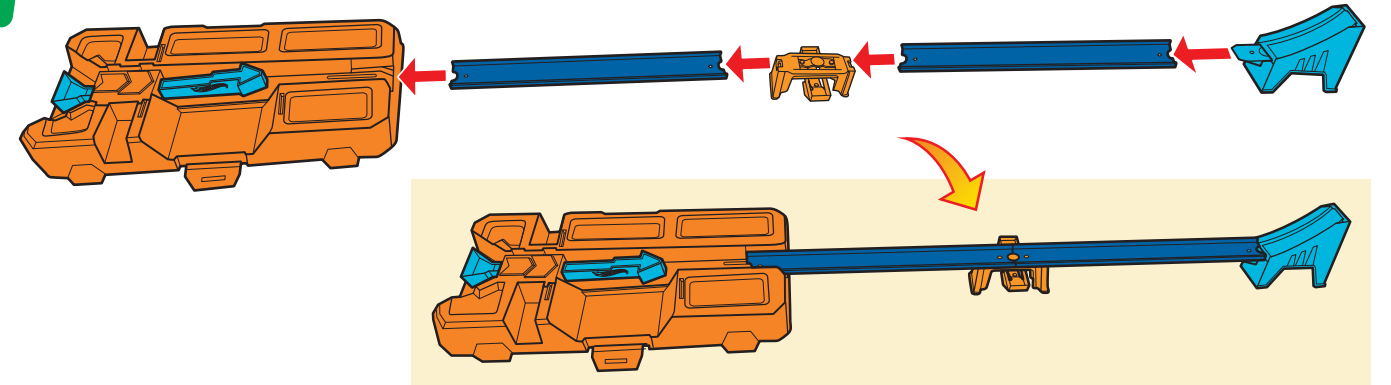

5

**NOW GRAB YOUR CAR AND GO! · ¡AGARRA TU AUTO Y ACELERA!
 ATTRAPEZ UNE VOITURE ET FONCEZ! · AGORA, PEGUE O CARRO E ACELERE!**

**LOAD YOUR CAR AND AIM. PULL BACK AND HOLD THE LAUNCHING ROD.
 COLOCA TU AUTO Y APUNTA. JALA HACIA ATRÁS LA VARILLA DE LANZAMIENTO Y SUJÉTALA.
 POSITIONNEZ VOTRE VOITURE ET VISEZ. TIREZ LA TIGE DE LANCEMENT VERS L'ARRIÈRE.
 COLOQUE O SEU CARRO E MIRE! PUXE E SEGURE A HASTE DE LANÇAMENTO.**

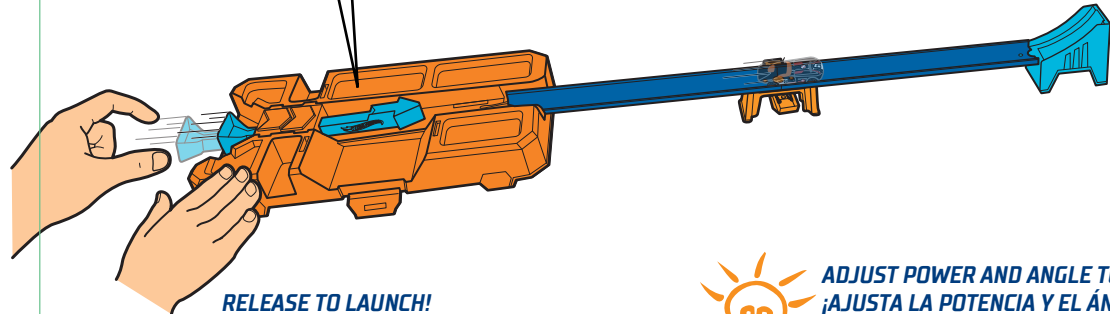
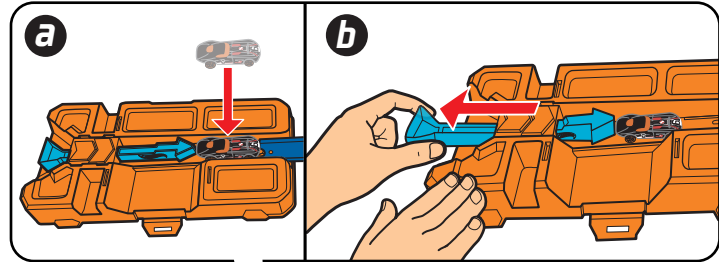

**RELEASE TO LAUNCH!
 ¡SUÉLTALA PARA LANZAR!
 RELÂCHEZ POUR LANCER!
 SOLTE PARA LANÇAR!**



**ADJUST POWER AND ANGLE TO KNOCK OVER ALL THE BARRELS!
 ¡AJUSTA LA POTENCIA Y EL ÁNGULO PARA DERRIBAR LOS BARRILES!
 AJUSTEZ L'ANGLE ET LA PUISSANCE POUR RENVERSER TOUS LES BARILS!
 AJUSTE A FORÇA DE LANÇAMENTO E O ÁNGULO PARA DERRUBAR OS BARRIS!**

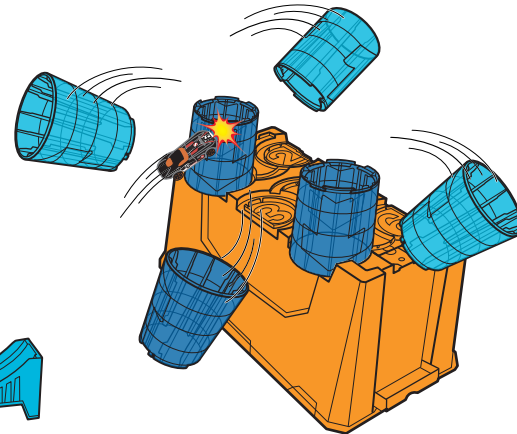

CONFIGURATION 2 · CONFIGURACIÓN 2 · CONFIGURAÇÃO 2

PARTS YOU NEED: · PIEZAS NECESARIAS: · PIÈCES NÉCESSAIRES: · PEÇAS QUE VOCÊ PRECISA:

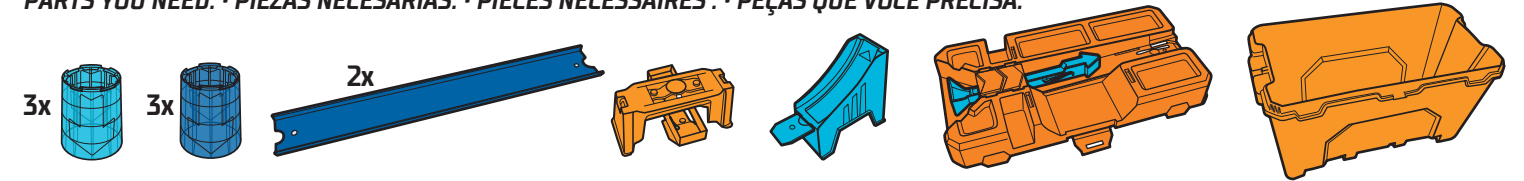

1

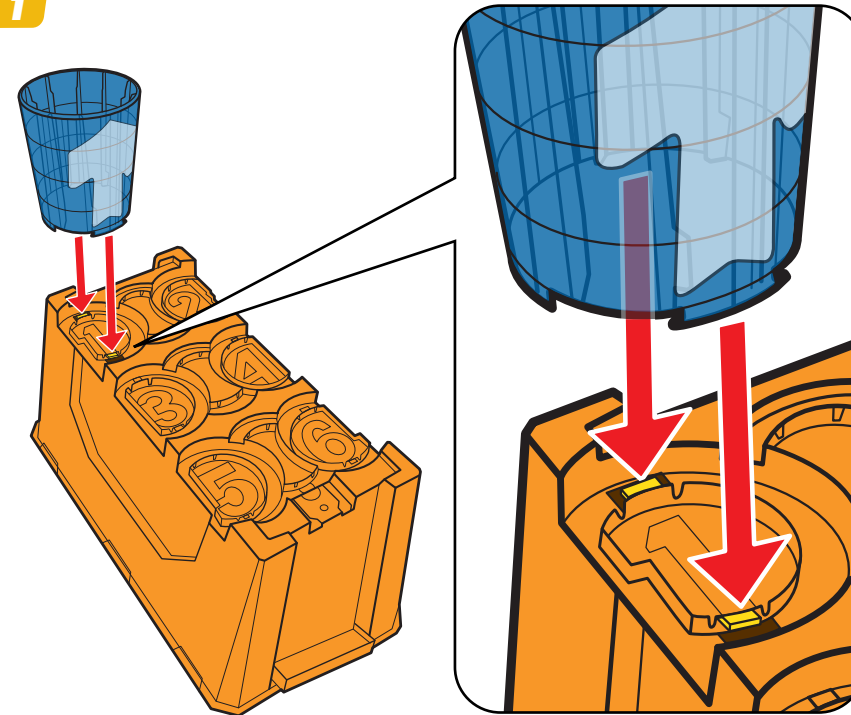

2

**TWIST CUP TO LOCK.
 GIRA EL VASO PARA TRABARLO
 TOURNER LE BARIL POUR VERROUILLER.
 GIRE O COPO PARA TRAVAR.**

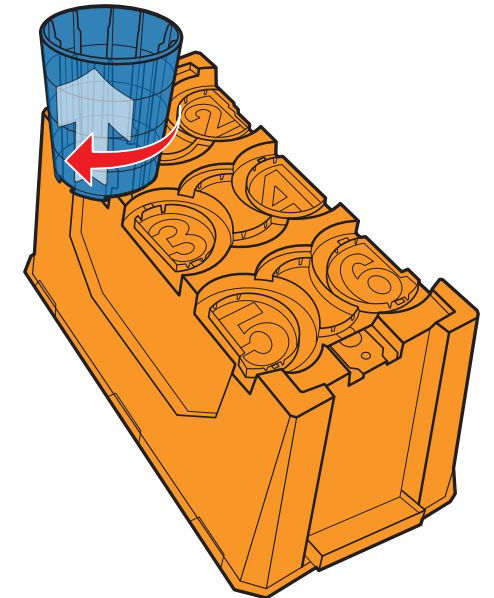

3 LOCK ALL 6 CUPS IN POSITION.
 TRABA LOS 6 VASOS EN POSICIÓN.
 VERROUILLER LES 6 BARILS EN POSITION.
 TRAVE OS 6 COPOS NA POSIÇÃO.

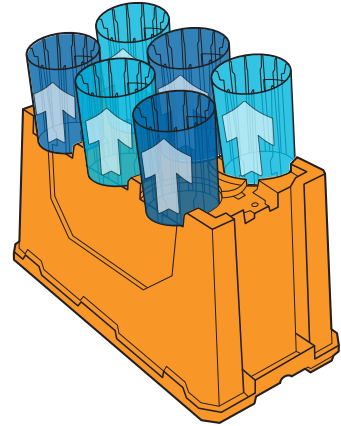

4

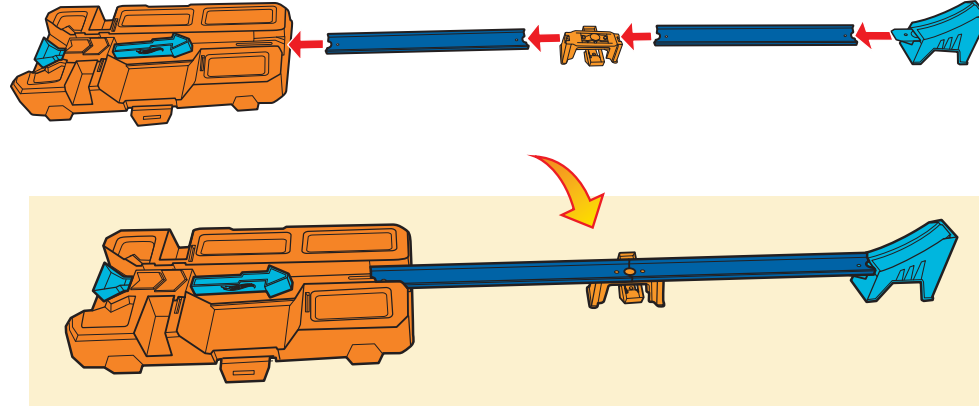

**NOW GRAB YOUR CAR AND GO! - ¡AGARRA TU AUTO Y ACELERA!
 ATTRAPEZ UNE VOITURE ET FONCEZ! - AGORA, PEGUE O CARRO E ACELERE!**

LOAD YOUR CAR AND AIM. PULL BACK AND HOLD THE LAUNCHING ROD.
 COLOCA TU AUTO Y APUNTA. JALA HACIA ATRÁS LA VARILLA DE LANZAMIENTO Y SUJÉTALA.
 POSITIONNEZ VOTRE VOITURE ET VISEZ. TIREZ LA TIGE DE LANCEMENT VERS L'ARRIÈRE.
 COLOQUE O SEU CARRO E MIRE! PUXE E SEGRE A HASTE DE LANÇAMENTO.

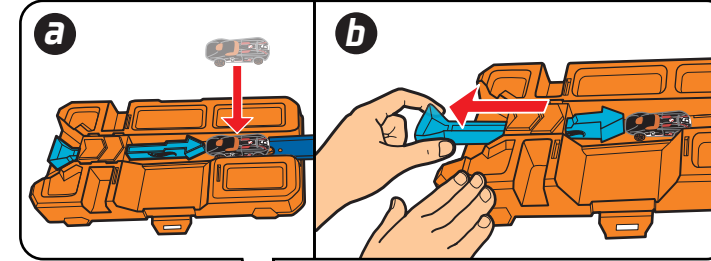

RELEASE TO LAUNCH!
 ¡SUÉLTALA PARA LANZAR!
 RELÂCHEZ POUR LANCER!
 SOLTE PARA LANÇAR!



ADJUST POWER AND ANGLE TO LAND YOUR CARS INTO THE CUPS!
 ¡AJUSTA LA POTENCIA Y EL ÁNGULO PARA QUE LOS AUTOS CAIGAN EN LAS TAZAS!
 AJUSTEZ L'ANGLE ET LA PUISSANCE POUR LANCER LES VOITURES DANS LES GOBELETS!
 AJUSTE A FORÇA DE LANÇAMENTO E O ÂNGULO PARA ACERTAR O CARRO DENTRO DOS COPOS!

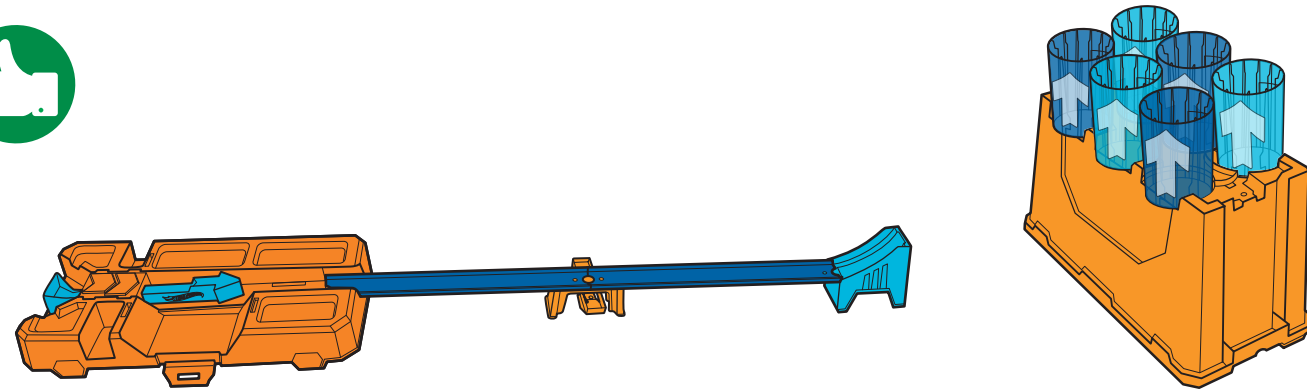

CONFIGURATION 3 · CONFIGURACIÓN 3 · CONFIGURAÇÃO 3

PARTS YOU NEED: · PIEZAS NECESARIAS: · PIÈCES NÉCESSAIRES : · PEÇAS QUE VOCÊ PRECISA:

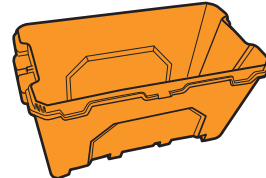
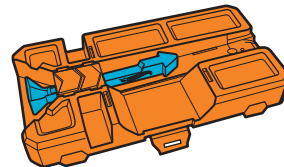
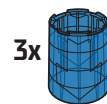
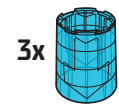

SET UP CONFIGURATION AS SHOWN.
CONFIGURA EL SET TAL COMO SE MUESTRA.
REPRODUISEZ LA CONFIGURATION ILLUSTRÉE.
MONTE DE ACORDO COM A FIGURA.

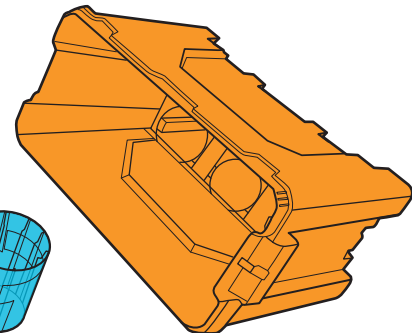
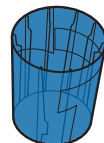
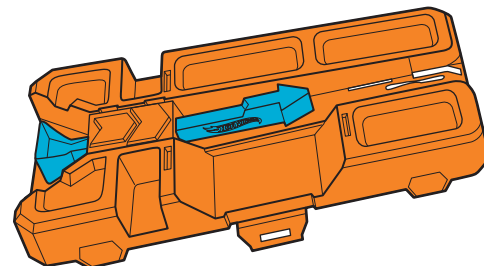

NOW GRAB YOUR CAR AND GO! · ¡AGARRA TU AUTO Y ACELERA!
ATTRAPEZ UNE VOITURE ET FONCEZ! · AGORA, PEGUE O CARRO E ACELERE!

LOAD YOUR CAR AND AIM. PULL BACK AND HOLD THE LAUNCHING ROD.
COLOCA TU AUTO Y APUNTA. JALA HACIA ATRÁS LA VARILLA DE LANZAMIENTO Y SUJÉTALA.
POSITIONNEZ VOTRE VOITURE ET VISEZ. TIREZ LA TIGE DE LANCEMENT VERS L'ARRIÈRE.
COLOQUE O SEU CARRO E MIRE! PUXE E SEGRE A HASTE DE LANÇAMENTO.

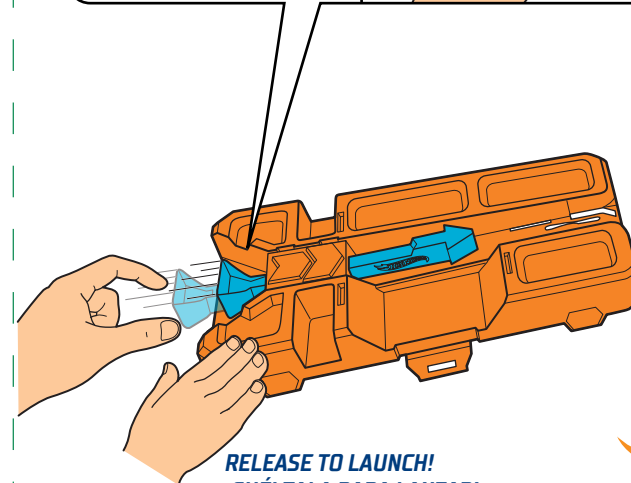
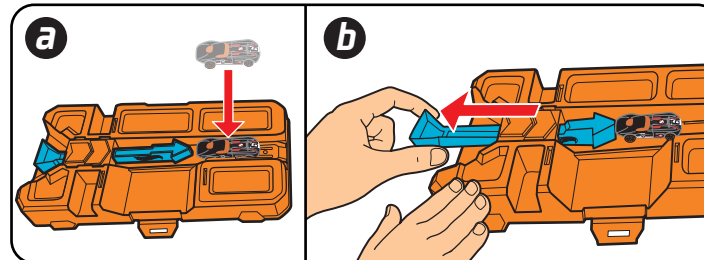

RELEASE TO LAUNCH!
¡SUÉLTALA PARA LANZAR!
RELÂCHEZ POUR LANCER!
SOLTE PARA LANÇAR!



ADJUST POWER AND ANGLE FOR BEST PERFORMANCE!
¡AJUSTA LA FUERZA DEL GOLPE Y EL ÁNGULO PARA OBTENER MEJORES RESULTADOS!
AJUSTEZ L'ANGLE ET LA PUISSANCE POUR UNE PERFORMANCE OPTIMALE!
AJUSTE A FORÇA DE LANÇAMENTO E O ÂNGULO PARA MELHOR DESEMPENHO!

CONFIGURATION 4 · CONFIGURACIÓN 4 · CONFIGURAÇÃO 4

PARTS YOU NEED: · PIEZAS NECESARIAS: · PIÈCES NÉCESSAIRES: · PEÇAS QUE VOCÊ PRECISA:

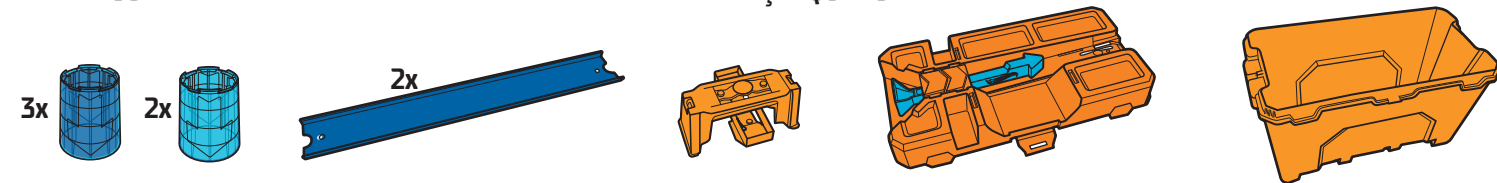

1

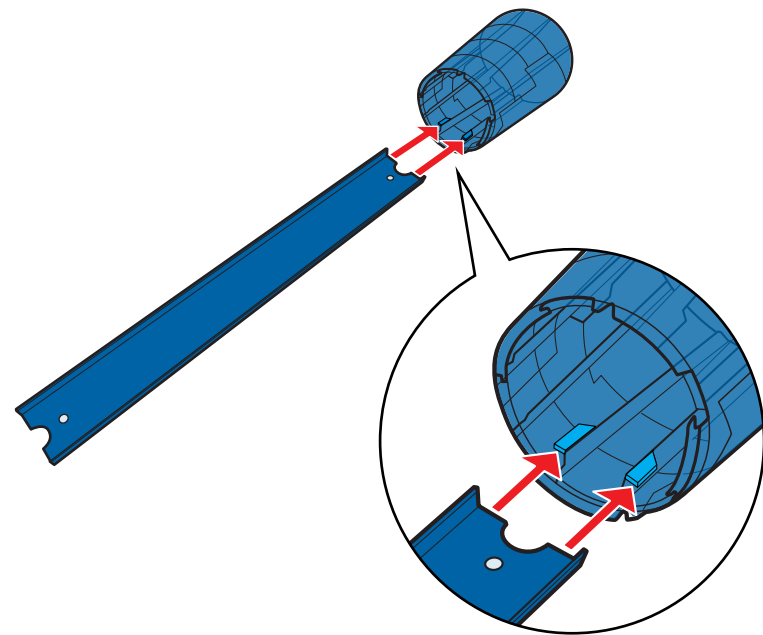

2

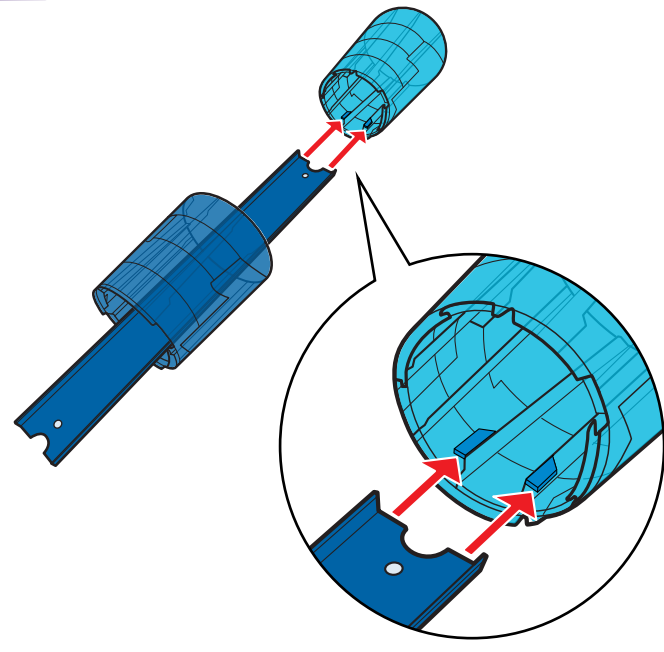

12

3

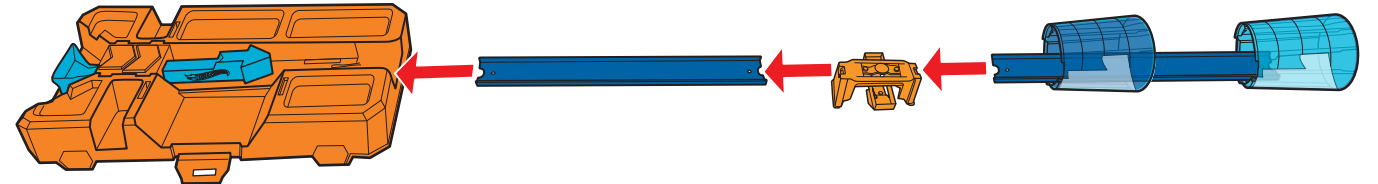

4

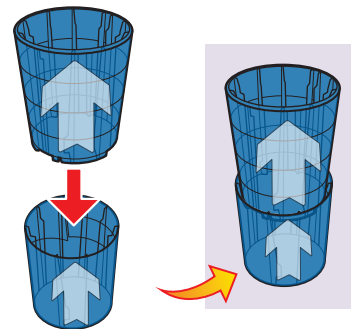

5

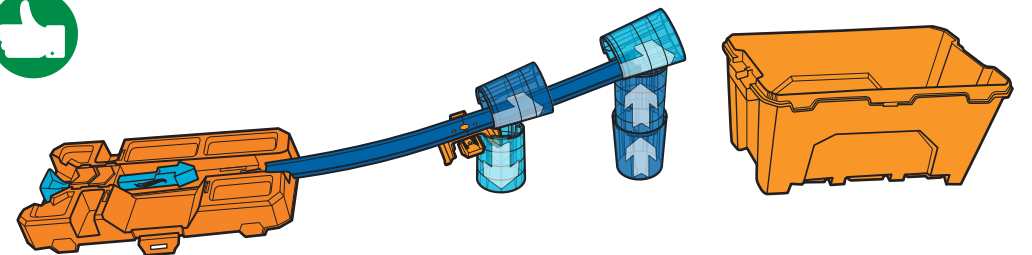
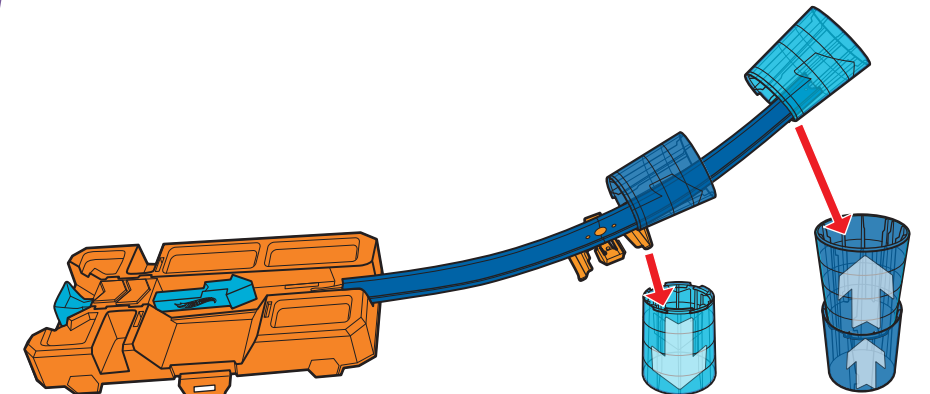

13

NOW GRAB YOUR CAR AND GO! • ¡AGARRA TU AUTO Y ACELERA!
 ATTRAPEZ UNE VOITURE ET FONCEZ! • AGORA, PEGUE O CARRO E ACELERE!

LOAD YOUR CAR AND AIM. PULL BACK AND HOLD THE LAUNCHING ROD.
 COLOCA TU AUTO Y APUNTA. JALA HACIA ATRÁS LA VARILLA DE LANZAMIENTO Y SUJÉTALA.
 POSITIONNEZ VOTRE VOITURE ET VISEZ. TIREZ LA TIGE DE LANCEMENT VERS L'ARRIÈRE.
 COLOQUE O SEU CARRO E MIRE! PUXE E SEGURE A HASTE DE LANÇAMENTO.

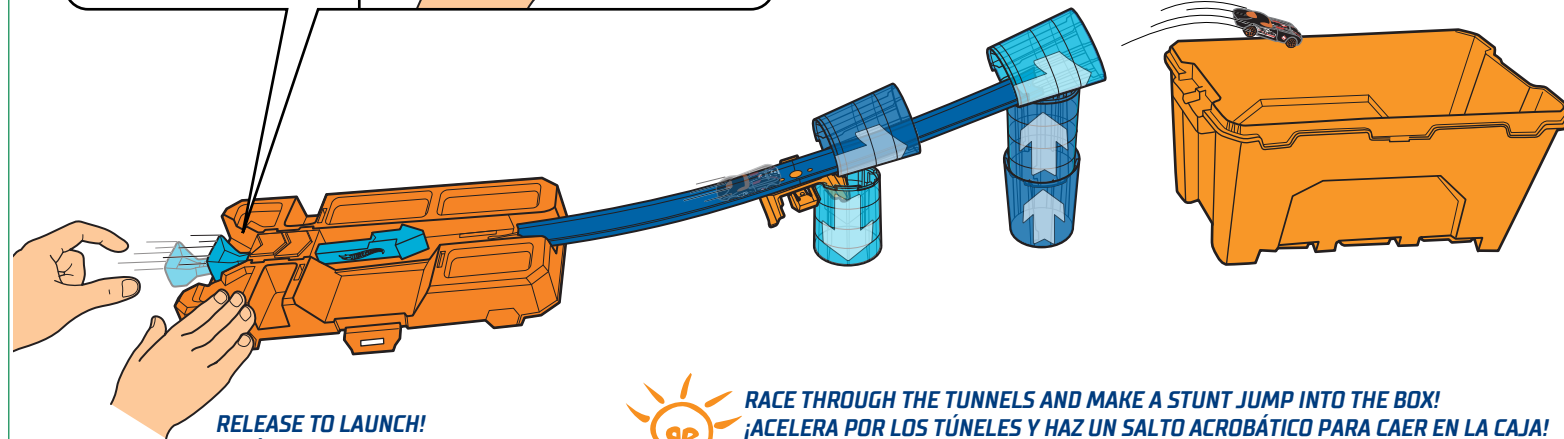
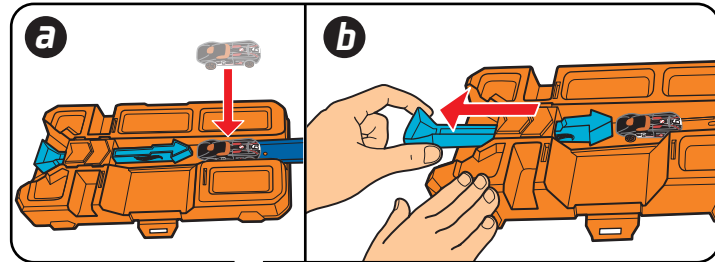

RELEASE TO LAUNCH!
 ¡SUÉLTALA PARA LANZAR!
 RELÂCHEZ POUR LANCER!
 SOLTE PARA LANÇAR!



RACE THROUGH THE TUNNELS AND MAKE A STUNT JUMP INTO THE BOX!
 ¡ACELERA POR LOS TÚNELES Y HAZ UN SALTO ACROBÁTICO PARA CAER EN LA CAJA!
 TRAVERSEZ LES TUNNELS ET RÉALISEZ UNE CASCADE DANS LE BAC!
 CORRA PELOS TÚNEIS E FAÇA UM SALTO NA CAIXA!

ALSO AVAILABLE: • TAMBIÉN DISPONIBLE: • ÉGALEMENT DISPONIBLES: • TAMBÉM DISPONÍVEL:

ADVERTISEMENT • PUBLICIDAD • INFORMATION PUBLICITAIRE • PUBLICIDADE



EACH SOLD SEPARATELY, SUBJECT TO AVAILABILITY. COLORS AND DECORATIONS MAY VARY. • SE VENDEN POR SEPARADO Y ESTÁN SUJETOS A DISPONIBILIDAD. LOS COLORES Y DECORACIÓN PUEDEN VARIAR DE LOS MOSTRADOS. • TOUS VENDUS SÉPARÉMENT, SELON LA DISPONIBILITÉ. LES COULEURS ET LES MOTIFS PEUVENT VARIER. • VENDIDOS SEPARADAMENTE, SUJETOS A DISPONIBILIDADE. AS CORES E AS DECORAÇÕES PODEM VARIAR.