

**ADULT ASSEMBLY REQUIRED**

COLORS AND DECORATIONS MAY VARY.  
2 VEHICLES INCLUDED. OTHER VEHICLES SOLD SEPARATELY.  
REQUIRES 6 D SIZE (LR20) ALKALINE BATTERIES (NOT INCLUDED). DISPOSE OF BATTERIES SAFELY.  
PLEASE KEEP THESE INSTRUCTIONS FOR FUTURE REFERENCE AS THEY CONTAIN IMPORTANT INFORMATION.

service.mattel.com  
**HOTWHEELS.COM**



GFH87\_0970\_G4  
1102147081\_DOM

**5-10**



**INSTRUCTIONS**



**COLOSSAL CRASH™**



**COLOSSAL CRASH™**  
**INSTRUCTIONS**



©2019 Mattel, Mattel, Inc., 636 Girard Avenue, East Aurora, NY 14092, U.S.A. Consumer Services  
1-800-624-6697. Mattel U.K. Ltd., Vanwall Business Park, Maidenhead SL6 4UB. Helpline 01628 500303.  
Mattel Australia Pty. Ltd., 458 Church St., Richmond, Victoria, 3121. Consumer Advisory Service - 1300 135  
312. Mattel South Africa (PTY) LTD, Office 10213, 30 Metrose Boulevard, Johannesburg 2196. Mattel East  
Asia Ltd., Room 503-09, North Tower, World Finance Centre, Harbour City, Tsimshatsui, HK, China. Tel.:  
(852) 3189-6500. Dharmport & Diederik Oeh: Mattel Southeast Asia Pte. Ltd., No 19-1, Tower 3 Avenue 7,  
Bangsar South City, No 8, Jalan Kerinci, 59200 Kuala Lumpur, Malaysia. Tel: 03-33419052.





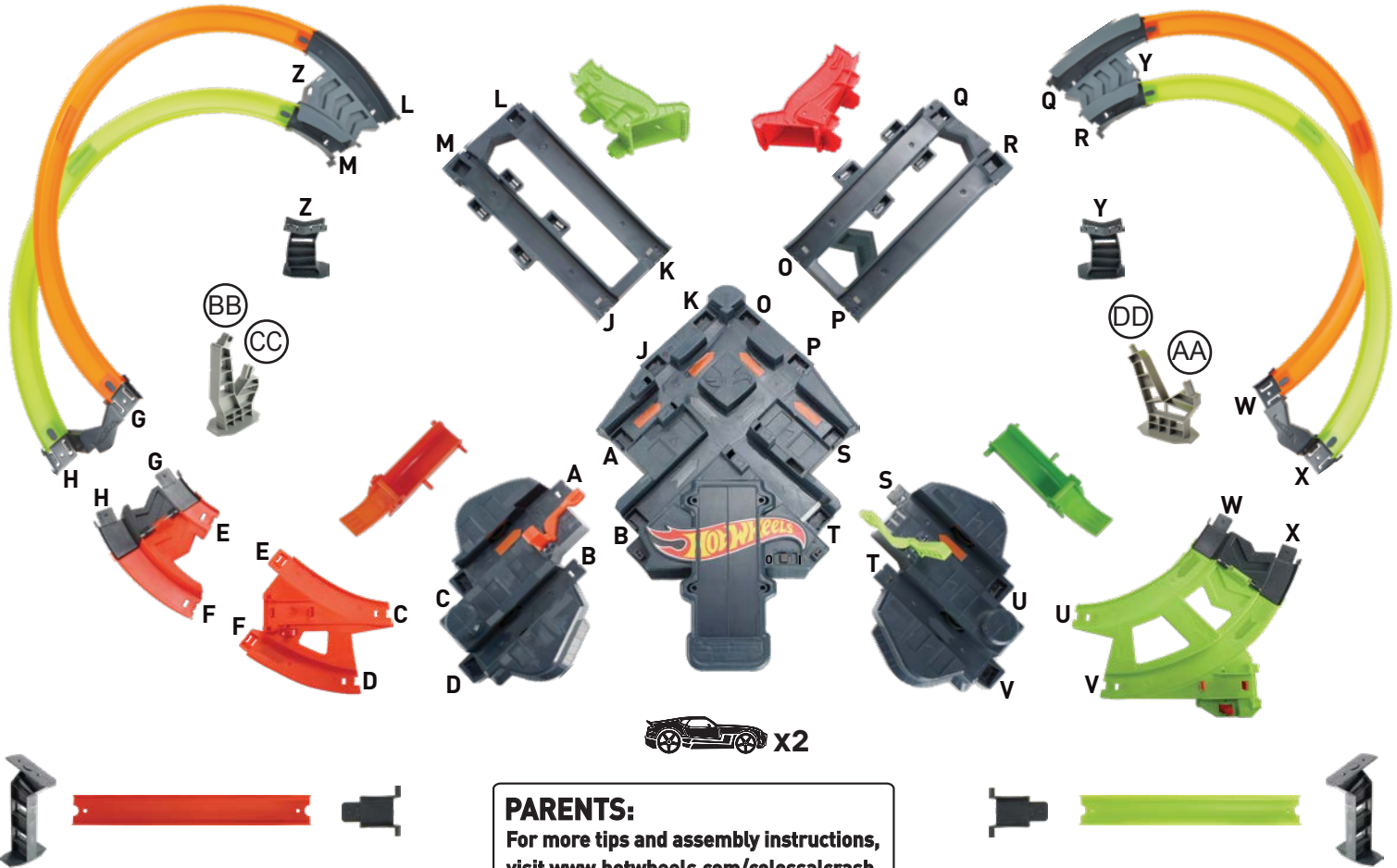

**PARENTS:**  
For more tips and assembly instructions,  
visit [www.hotwheels.com/colossalcrash](http://www.hotwheels.com/colossalcrash)

- Unscrew the battery cover with a Phillips head screwdriver (not included).
- Install 6 new D (LR20) alkaline batteries (not included) in the battery box.
- Replace the battery cover and tighten screws.
- Replace batteries if the booster can no longer propel vehicles through the track set.
- Dispose of batteries safely.
- For longer life, use alkaline batteries.
- When exposed to an electrostatic source, the product may malfunction. To resume normal operation, remove and reinstall the batteries.
- The toy is not to be connected to more than the recommended number of power supplies.



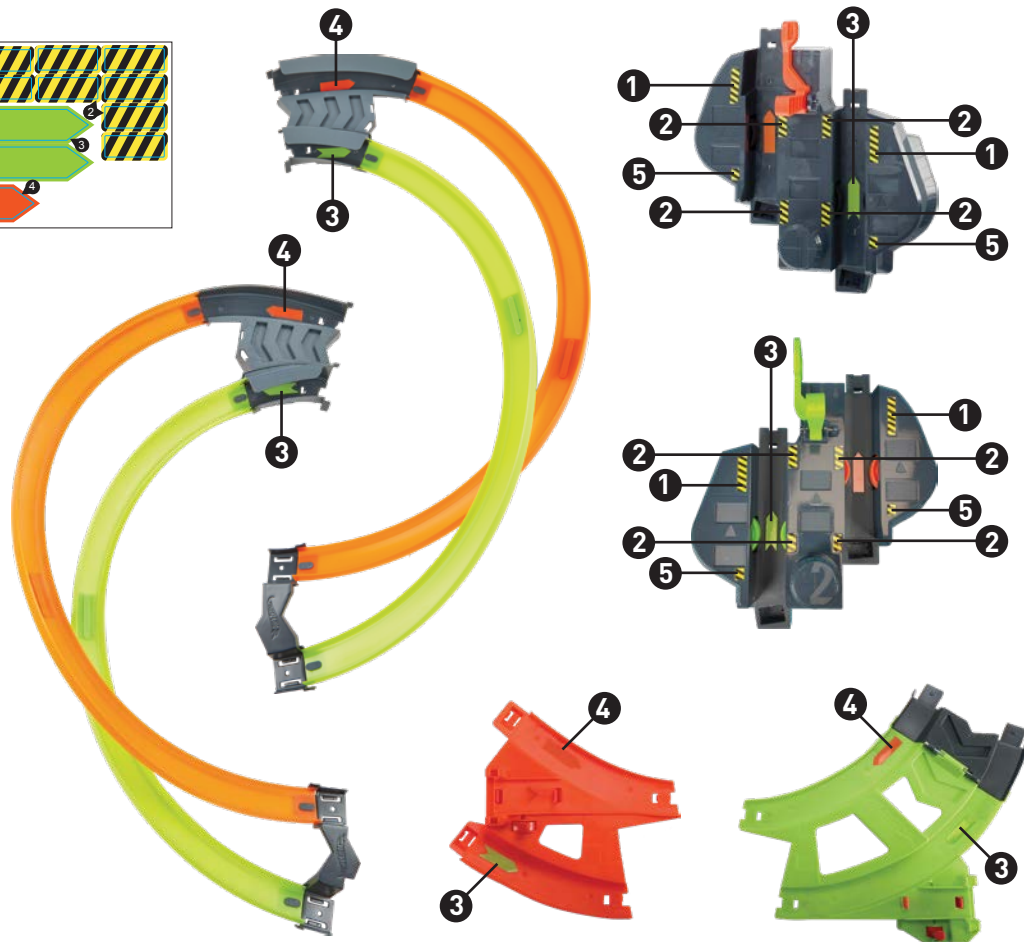
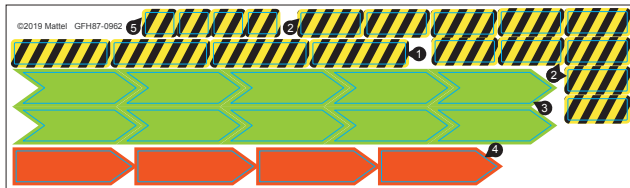

BUILD 3 DIFFERENT ZONES OF YOUR TRACK SET BEFORE THE FINAL ASSEMBLY.

## ZONE 2

PAGES 8-9



## ZONE 1

PAGES 6-7



## ZONE 3

PAGES 10-11





REFER TO IMAGE ON THE RIGHT FOR EXACT LOCATION OF EACH PART.

### PARTS YOU'LL NEED:

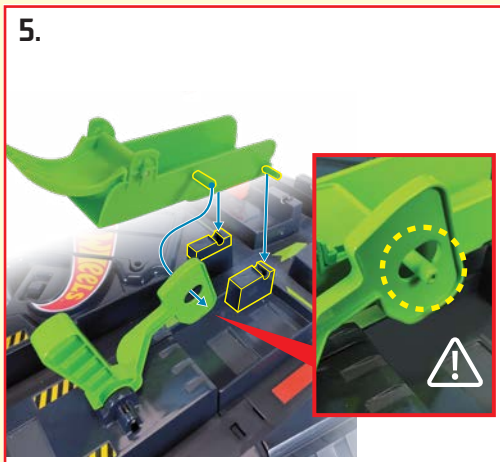
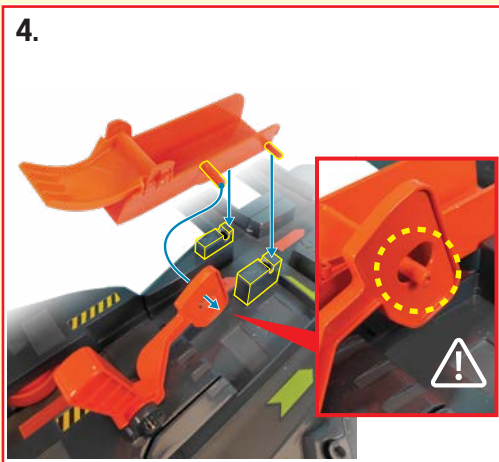
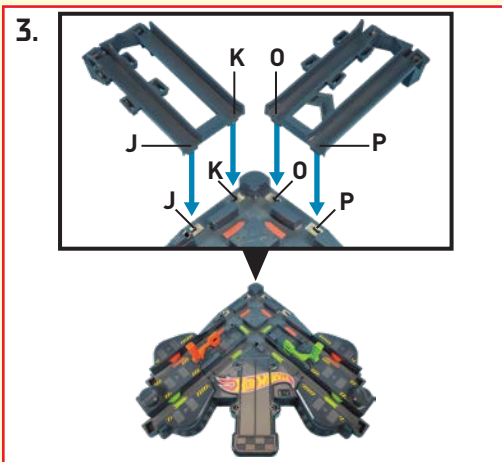
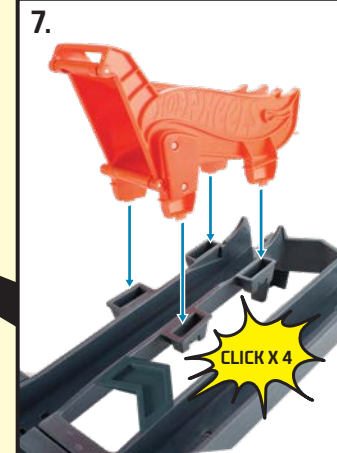
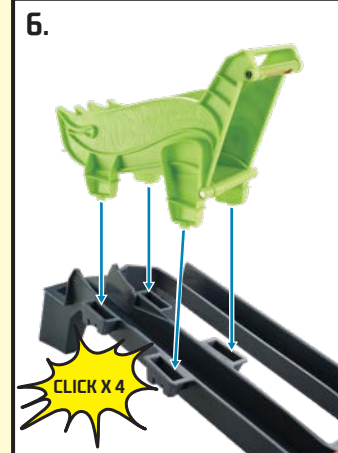
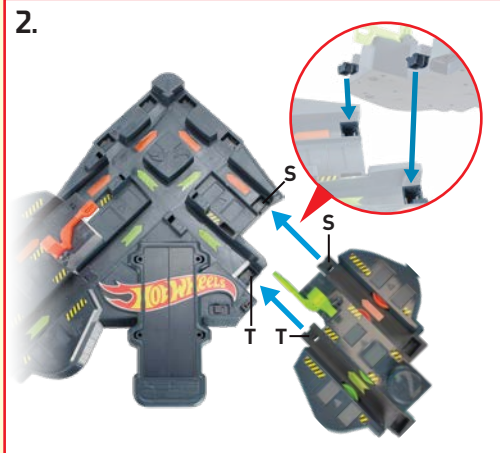
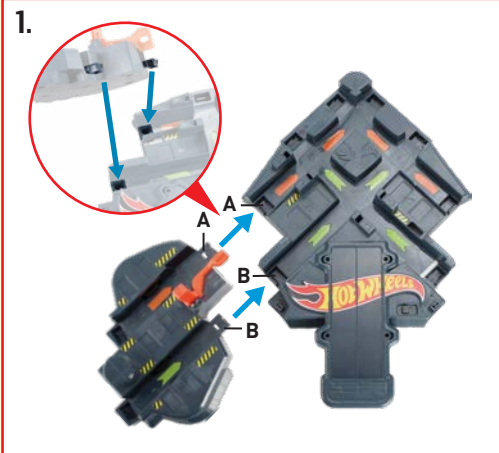

REFER TO IMAGE ON THE RIGHT FOR EXACT LOCATION OF EACH PART.

PARTS YOU'LL NEED:

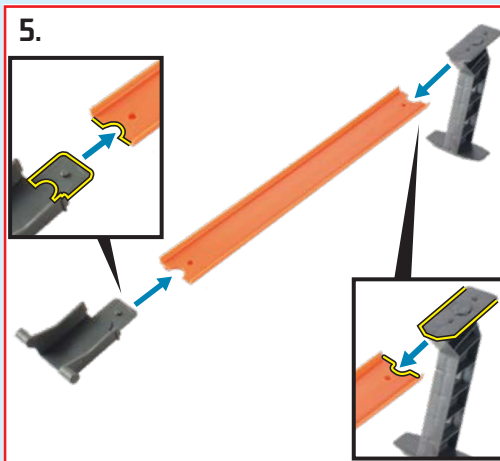
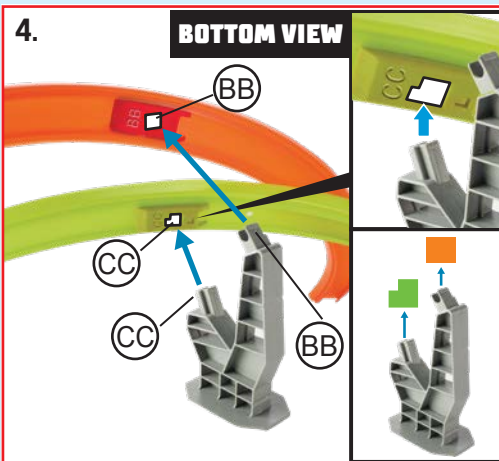
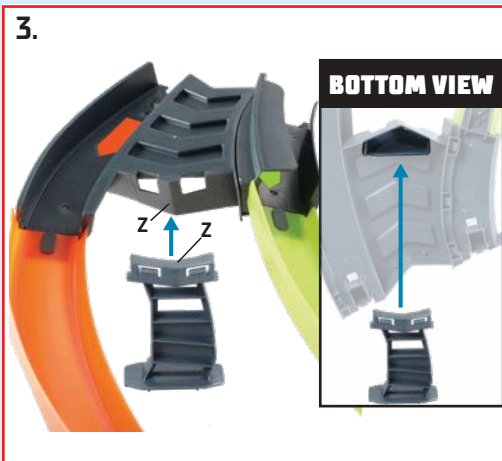
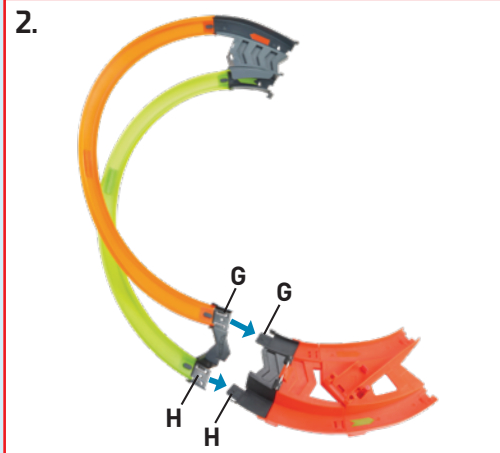
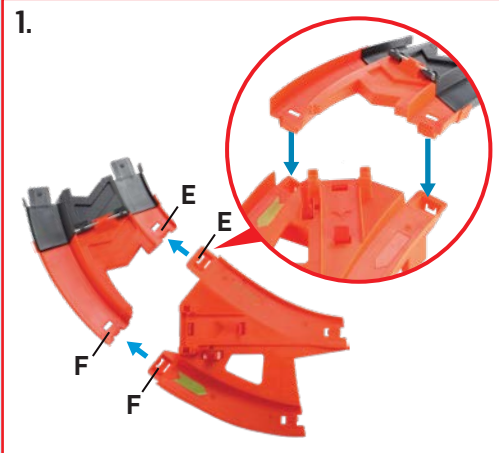
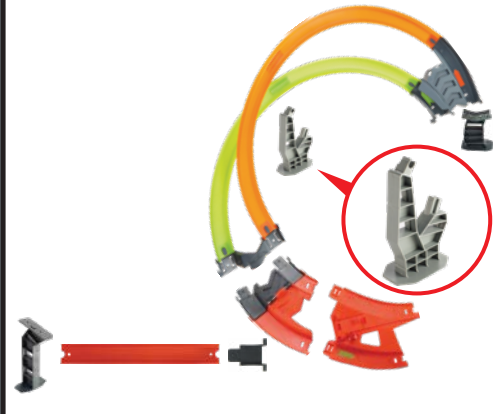



REFER TO IMAGE ON THE RIGHT FOR EXACT LOCATION OF EACH PART.

PARTS YOU'LL NEED:

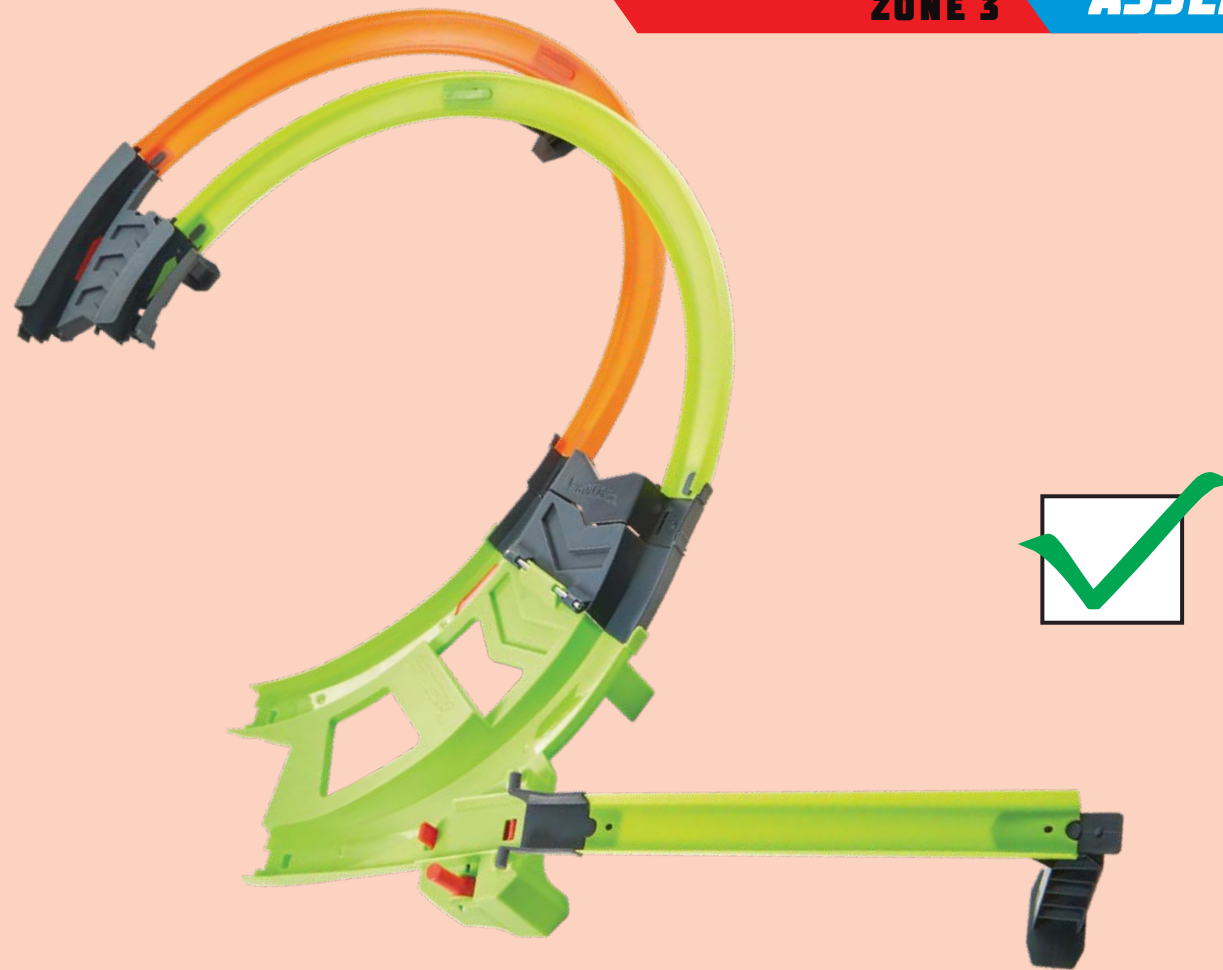
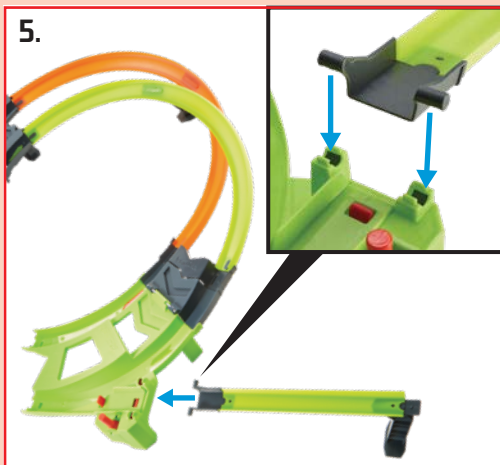
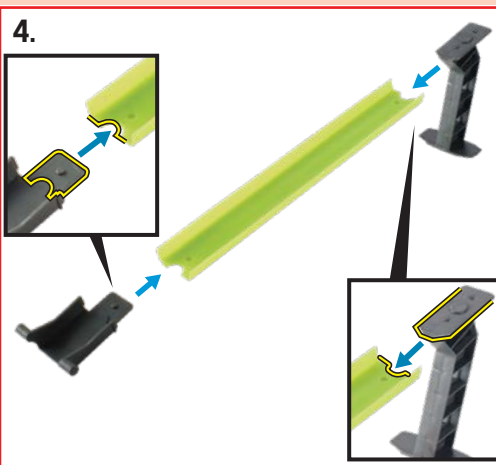
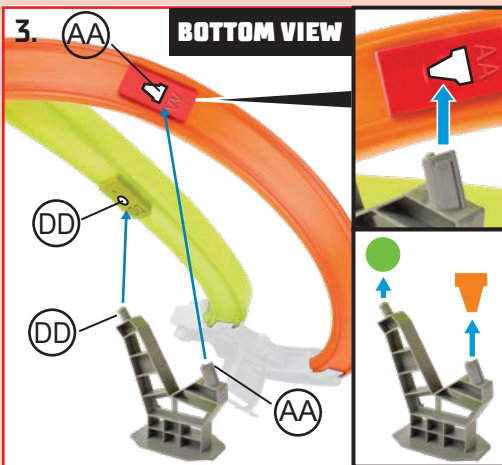
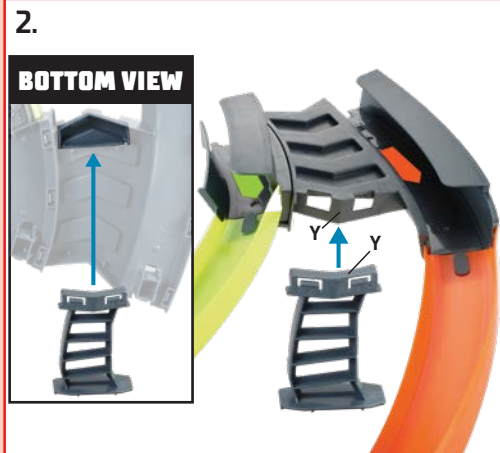
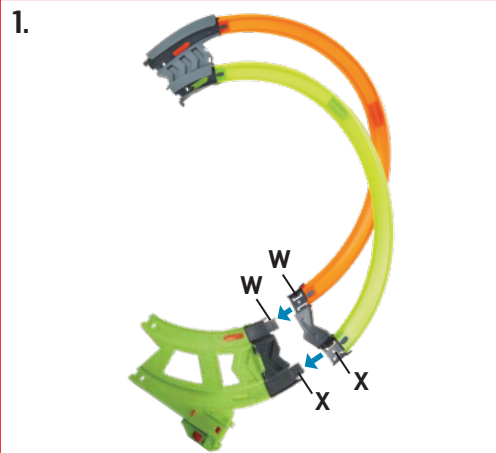
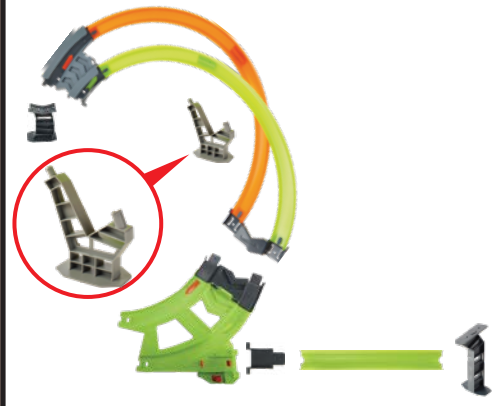

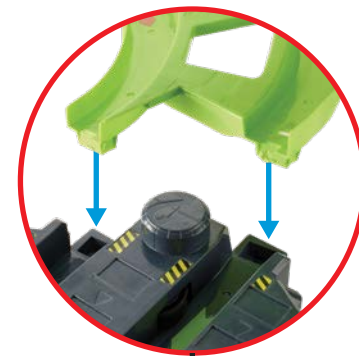
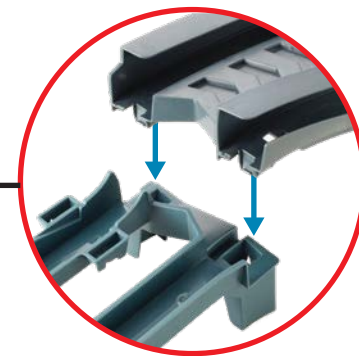
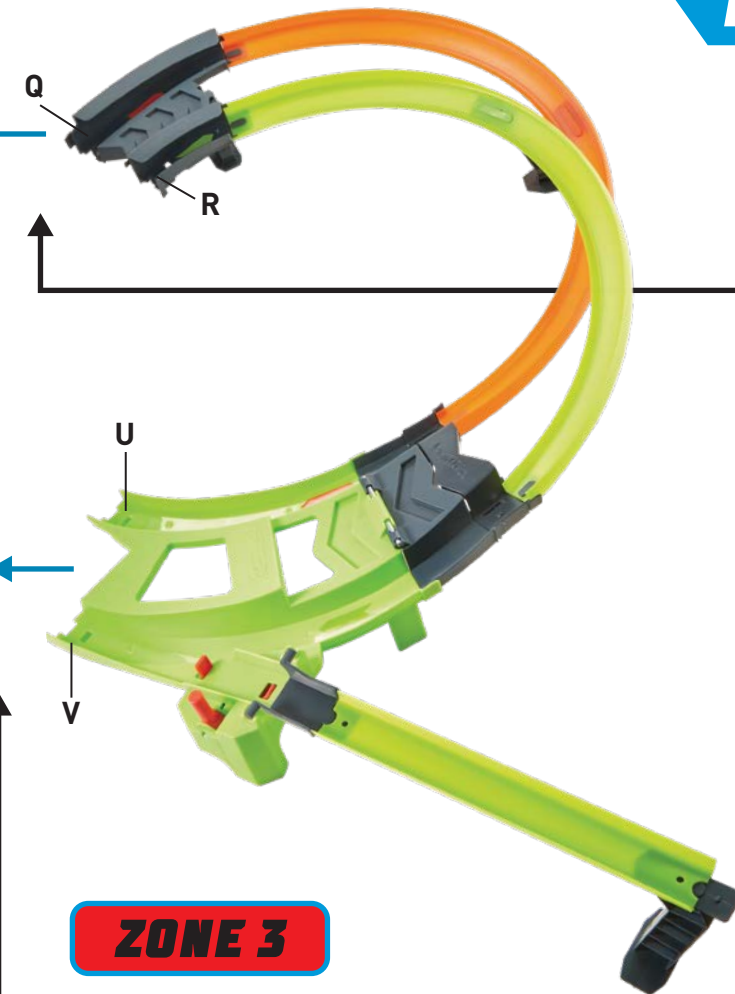
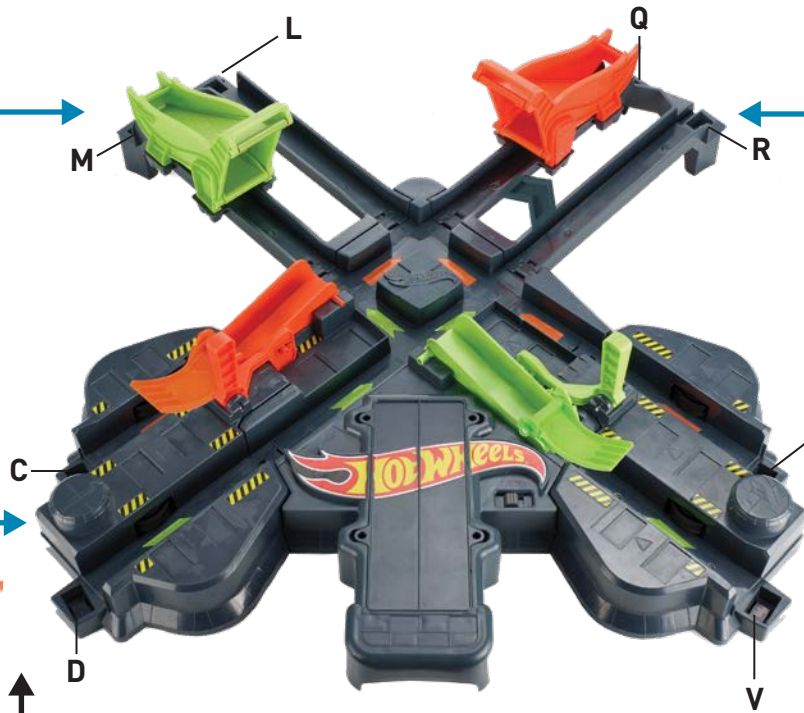
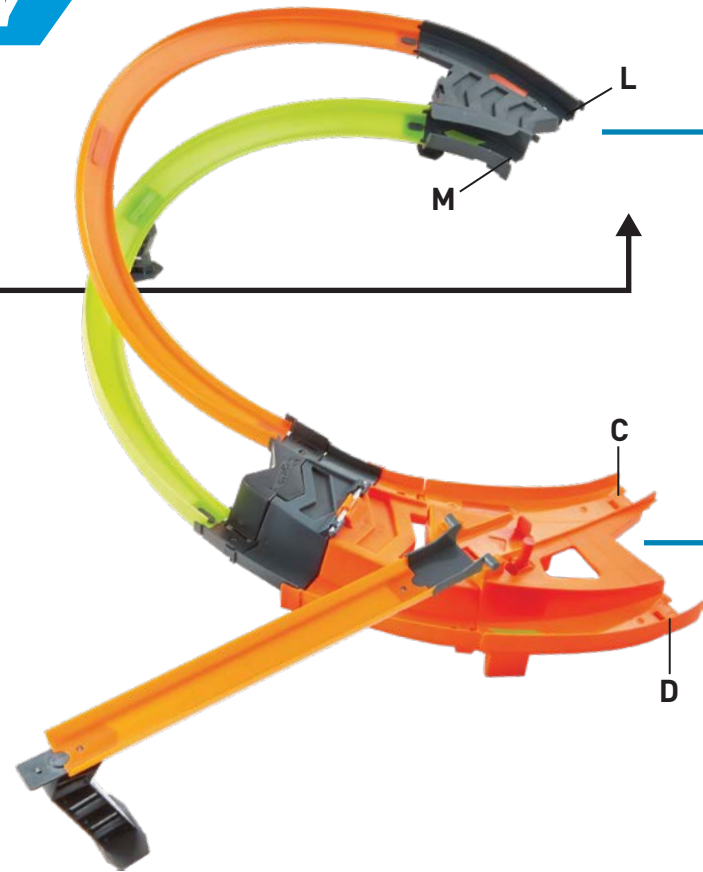
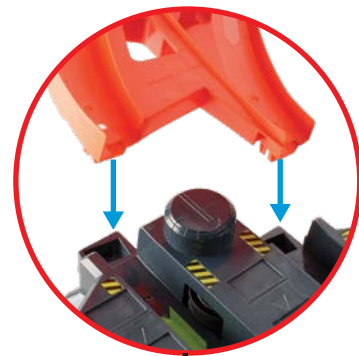
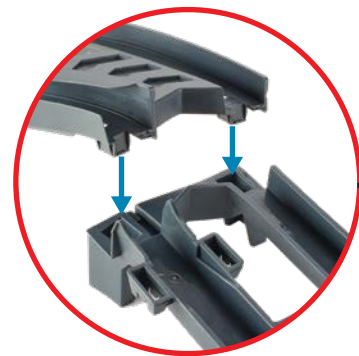



**1. SWITCH ON THE BOOSTER. LOAD CARS ON THE STARTING RAMPS TO GET READY FOR THE NON-STOP HIGH-SPEED CRASHES!**



0 = OFF 1 = ON



2.



ADJUST JUMP RAMP TO RACE STRAIGHT THROUGH OR MAKE STUNT JUMPS!



CRASH ZONE!

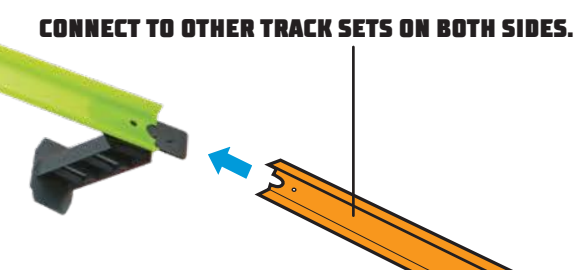
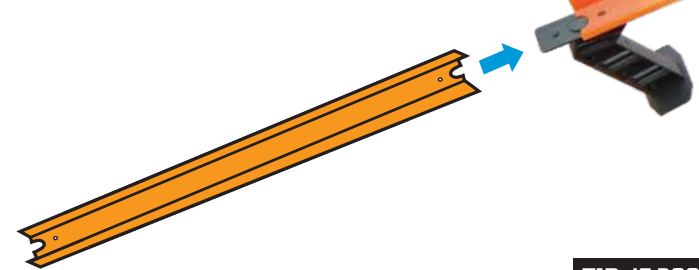

CONNECT TO OTHER TRACK SETS ON BOTH SIDES.



- 1 PUSH FORWARD TO RELEASE ONE CAR.
- 2 PULL BACK TO RELEASE MULTIPLE CARS.

NOT FOR USE WITH SOME HOT WHEELS® VEHICLES. TWO VEHICLES INCLUDED. ADDITIONAL VEHICLES SOLD SEPARATELY. OTHER HOT WHEELS® TRACKS AND SETS SOLD SEPARATELY.

**TIP:** IF BOOSTER STOPS, RESET IT BY TURNING THE POWER OFF AND ON AGAIN.

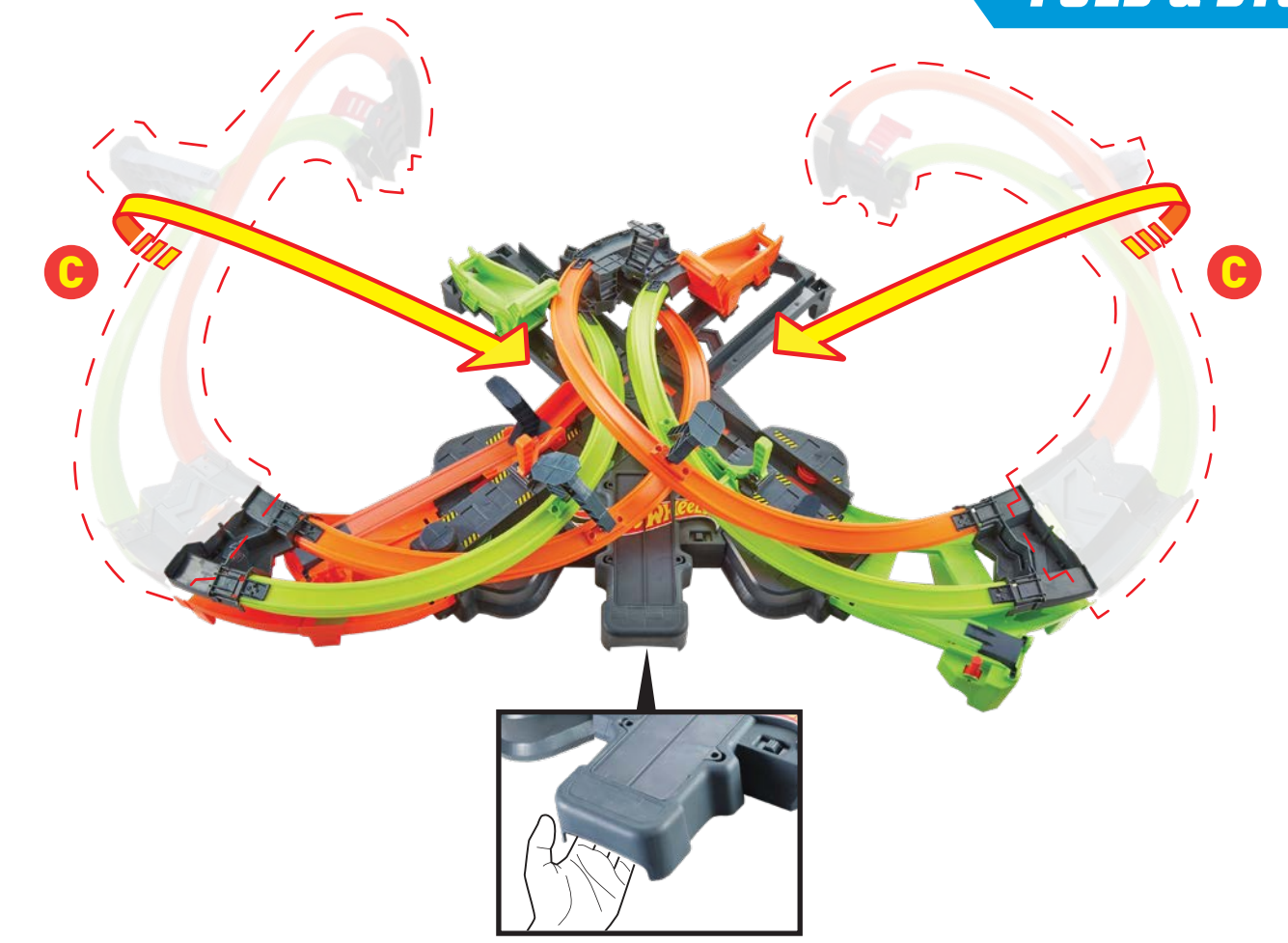

**HIDDEN HANDLE**