

RACE AROUND RADIATOR SPRINGS

INSTRUCTIONS

4+



Please keep these instructions for future reference as they contain important information.

CONTENTS

Letters shown connect to each other and are found on the bottom of track pieces.

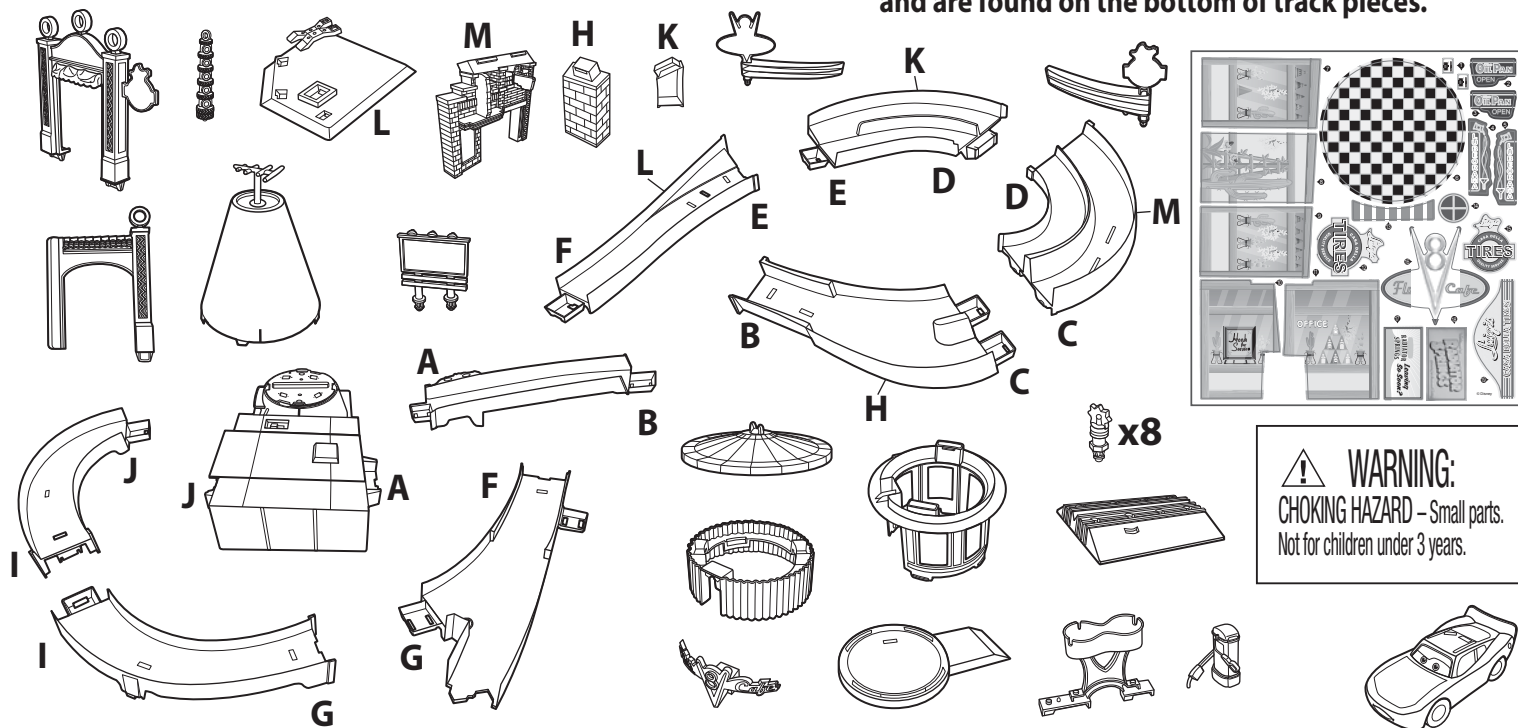

WARNING:
CHOKING HAZARD – Small parts.
Not for children under 3 years.

1 BATTERY INSTALLATION

- Requires 4 "D" size (LR20) alkaline batteries (not included).
- Unscrew the battery cover with a Phillips head screwdriver (not included).
- Install 4 new "D" size (LR20) alkaline batteries (not included) in the battery box.
- Replace battery cover and tighten screws.
- For longer life, use alkaline batteries.
- Replace batteries when booster can no longer propel car through the track set.
- Dispose of batteries safely.
- When exposed to an electrostatic source, the product may malfunction. To resume normal operation, remove and reinstall the batteries.

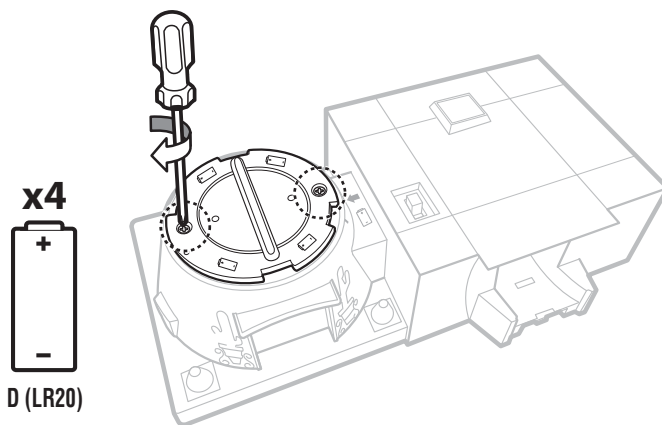

©2018 Mattel. ® and ™ designate U.S. trademarks of Mattel, except as noted. Mattel, Inc., 636 Girard Avenue, East Aurora, NY 14052, U.S.A. Consumer Services 1-800-524-8697 or 1-877-219-8335 (for products that can be controlled by smart devices). Mattel U.K. Ltd., Vanwall Business Park, Maidenhead SL6 4UB. Helpline 01628 500303. Mattel Australia Pty., Ltd., Richmond, Victoria. 3121. Consumer Advisory Service - 1300 135 312. Mattel South Africa (PTY) LTD, Office 102 I3, 30 Melrose Boulevard, Johannesburg 2196. Mattel East Asia Ltd., Room 503-09, North Tower, World Finance Centre, Harbour City, Tsimshatsui, HK, China. Tel.: (852) 3185-6500. Diimport & Diedarkan Oleh: Mattel Southeast Asia Pte. Ltd., No 19-1, Tower 3 Avenue 7, Bangsar South City, No 8, Jalan Kerinchi, 59200 Kuala Lumpur, Malaysia. Tel: 03-33419052.



2 / APPLY LABELS

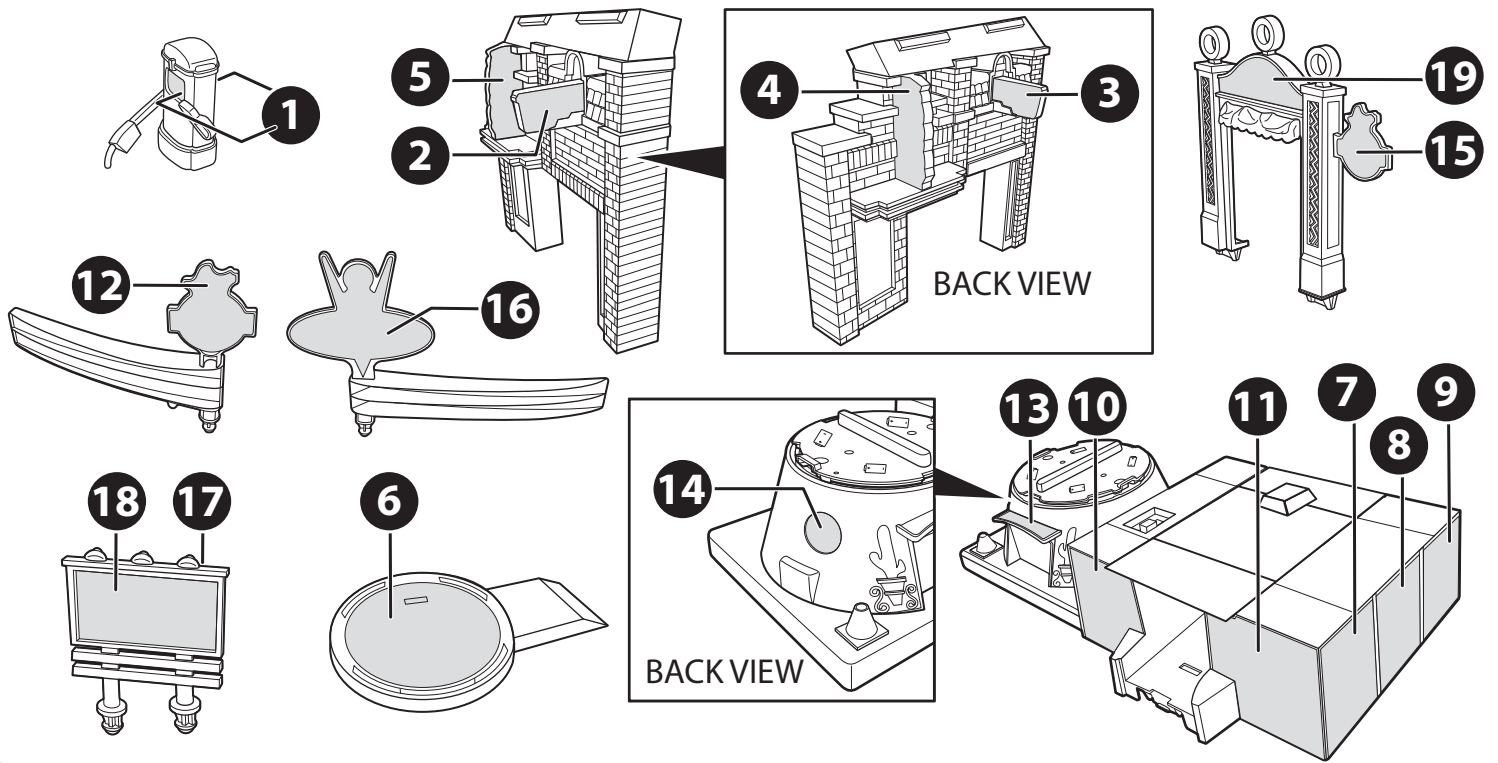

3 / ASSEMBLY

Refer to molded letters on the bottom of the pieces for easy assembly.

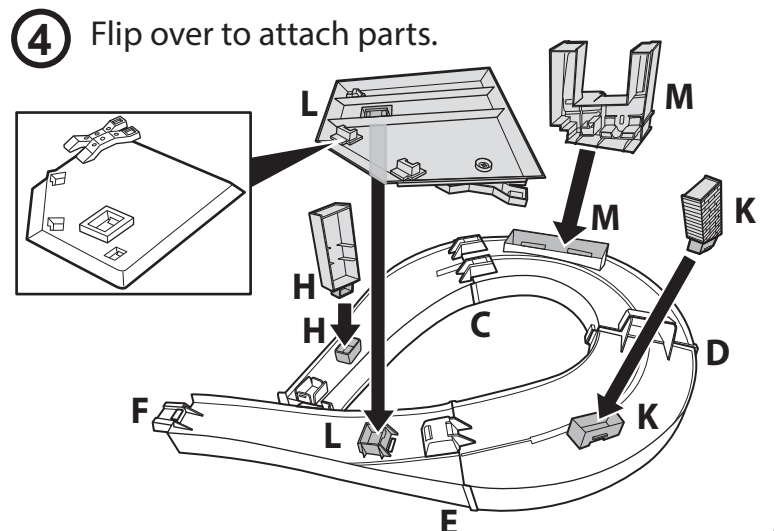
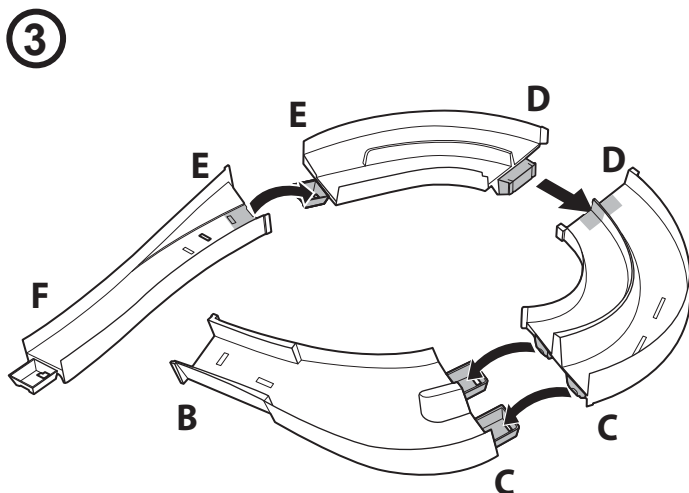
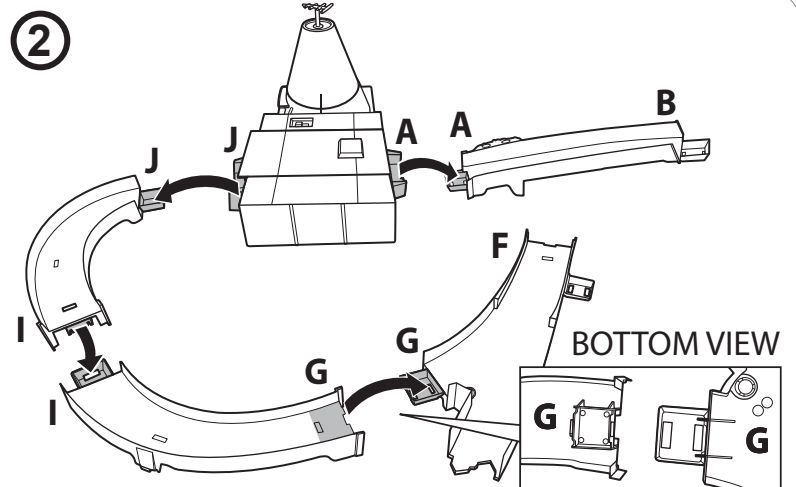
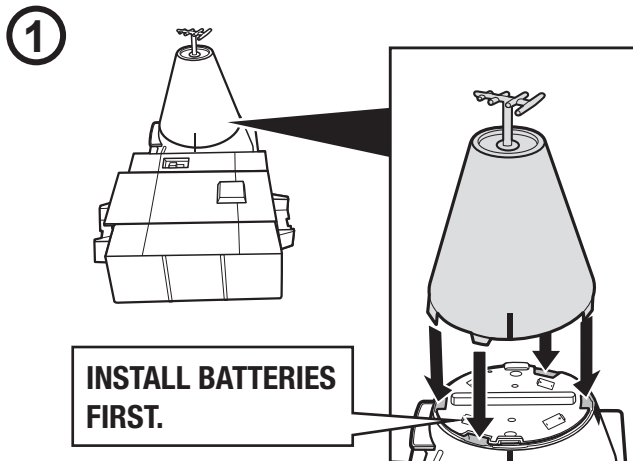

5

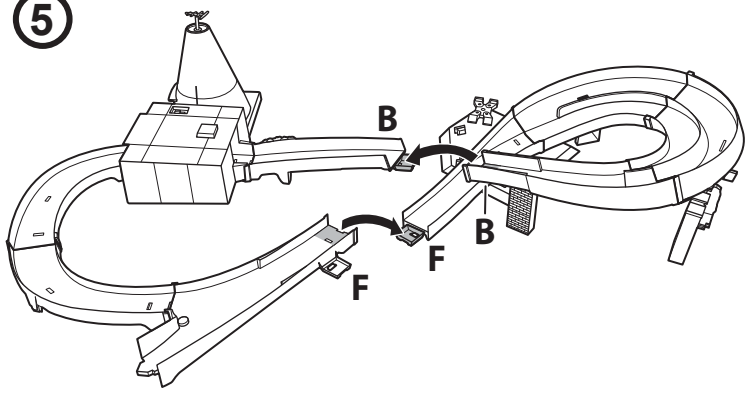

6

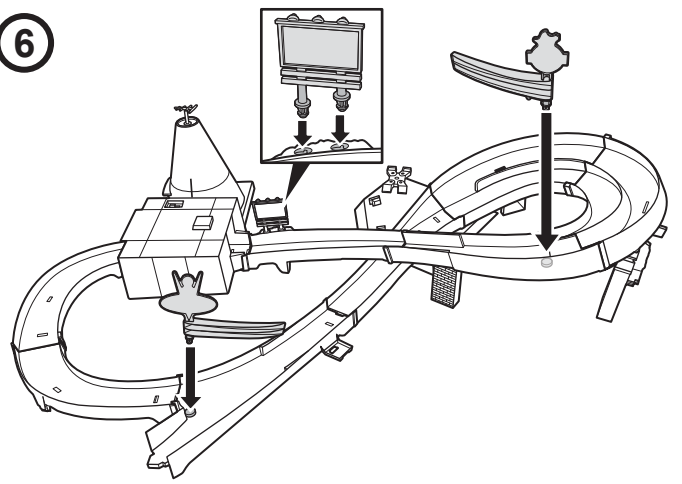

7

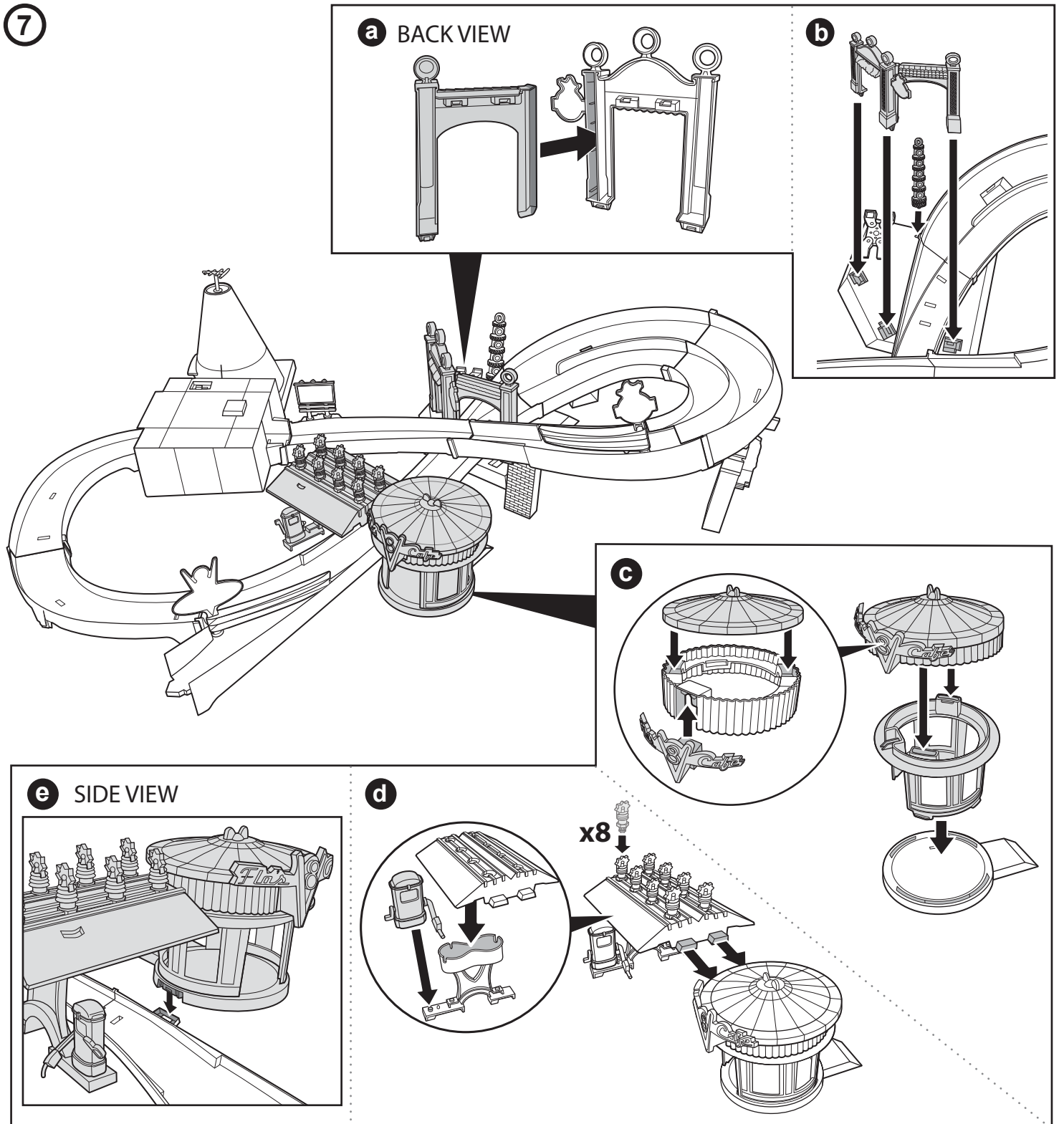

4 / TO PLAY

- ① Power on and move lane changers. Push vehicle through booster and race along the outside lane for a non-stop race!

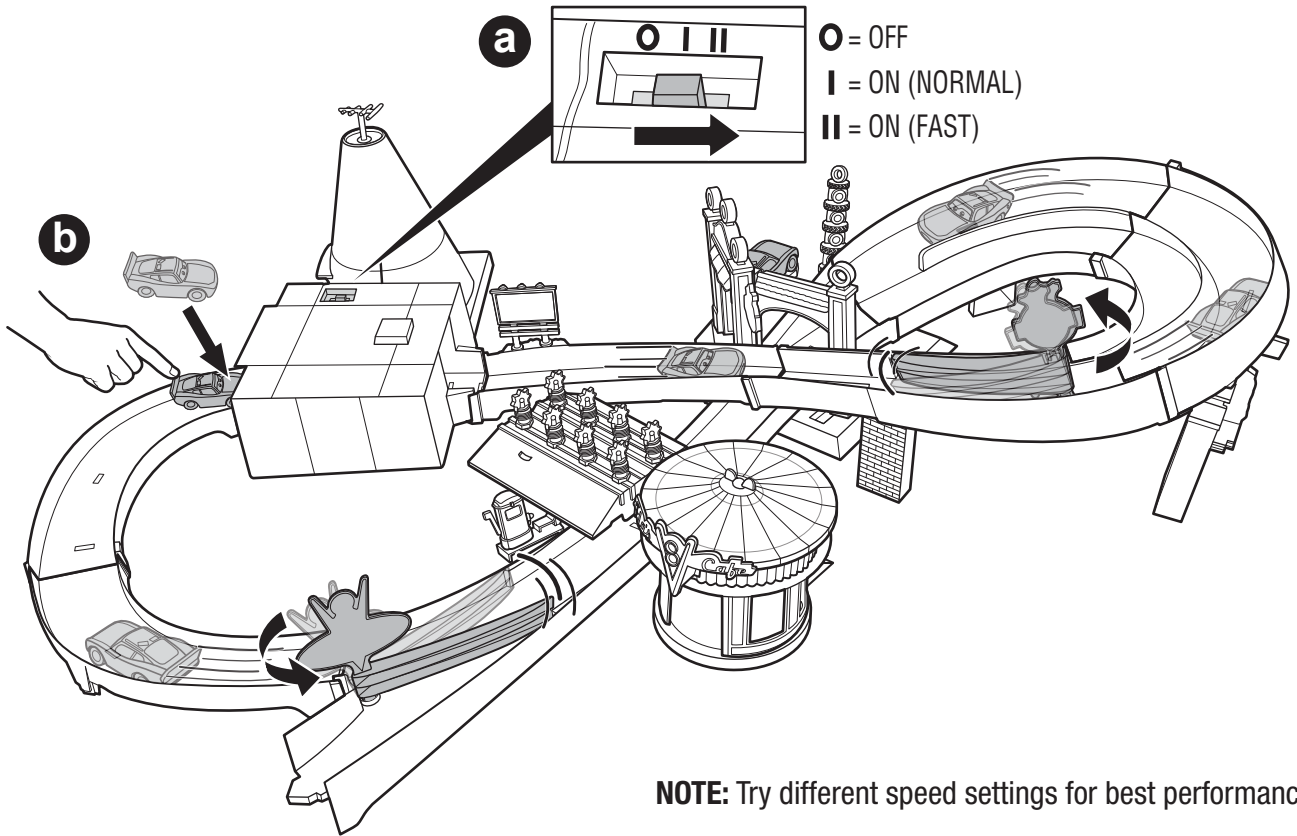

- ② Switch to the fast lane and race on! Stop by and service vehicles in town!

