

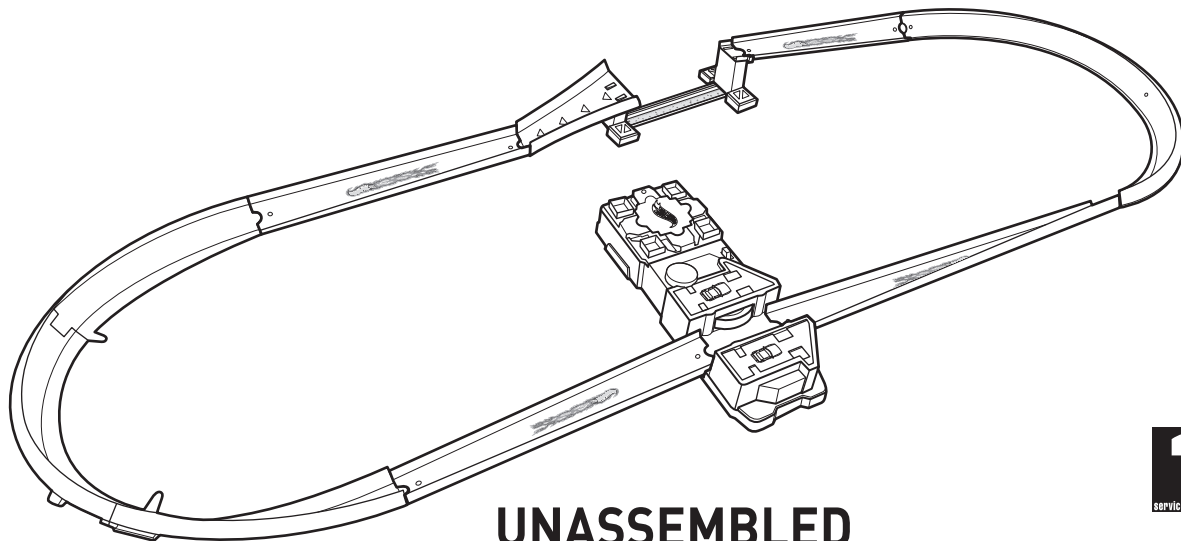

# INSTRUCTIONS

## HOT CURVES SUPER JUMP™



**5+**

[service.mattel.com](http://service.mattel.com)

**HOTWHEELS.COM**

### UNASSEMBLED

REQUIRES 2-D (LR20) ALKALINE BATTERIES (NOT INCLUDED).  
DISPOSE OF BATTERIES SAFELY.

PLEASE KEEP THESE INSTRUCTIONS FOR FUTURE  
REFERENCE AS THEY CONTAIN IMPORTANT INFORMATION.



G6R40\_0970\_G1  
1102240286\_DOM

# CONTENTS

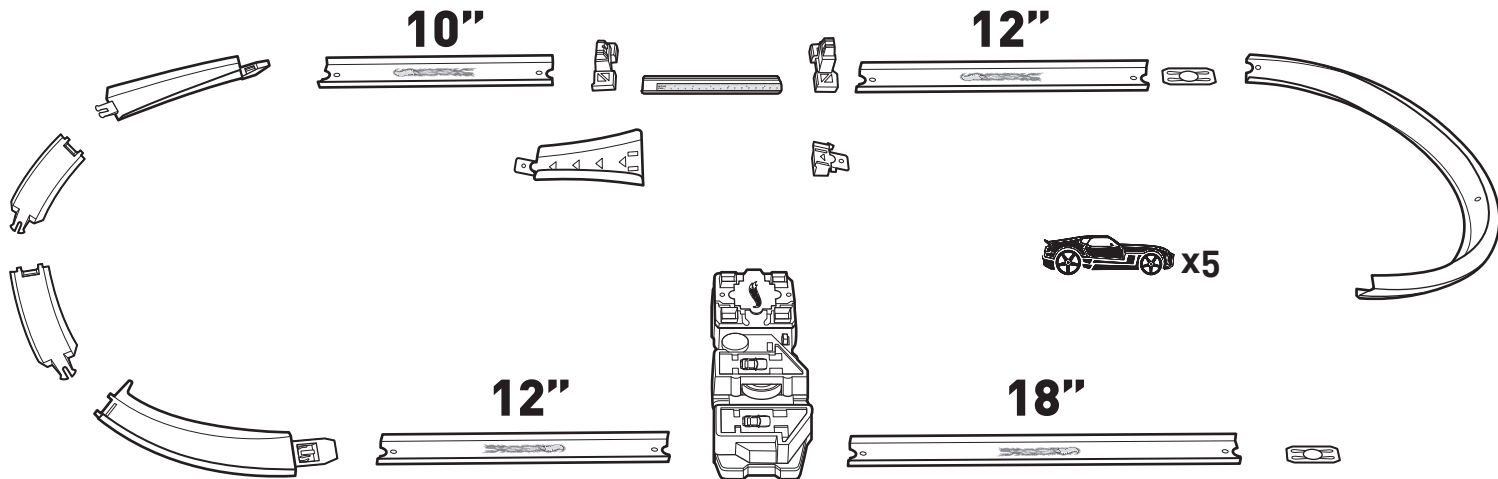

LABEL SHEET

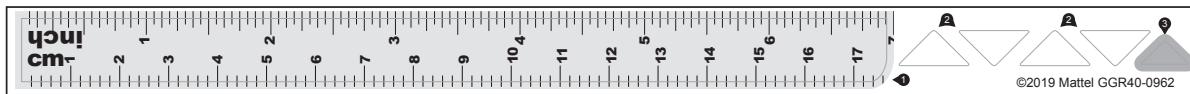



# BATTERY INSTALLATION

- Unscrew battery cover with a Phillips head screwdriver (not included).
- Install 2 new D-size (LR20) alkaline batteries (not included) in the battery box.
- Replace battery cover and tighten screws.
- For longer life, use alkaline batteries.
- Replace batteries if booster can no longer proper cars through the track set.
- Remove batteries and dispose of them safely.
- If product malfunctions, turn power OFF for a few seconds, then ON again. This should reset your product and let you resume normal operation.

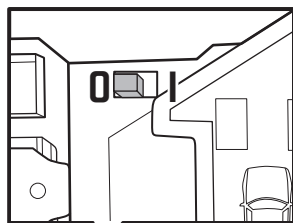
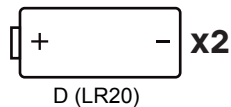

0 = OFF  
1 = ON

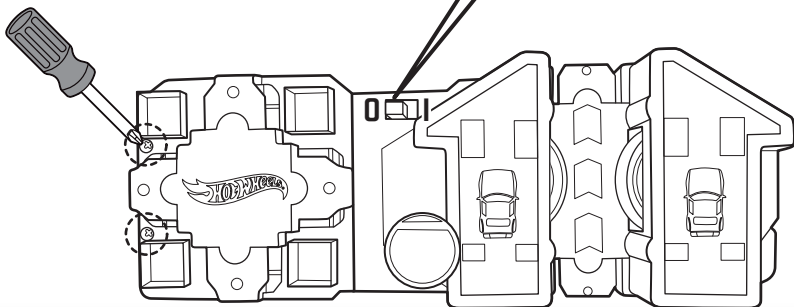

# APPLY LABELS

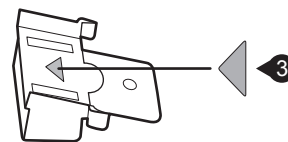
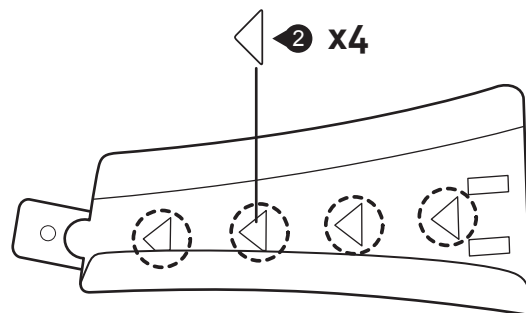
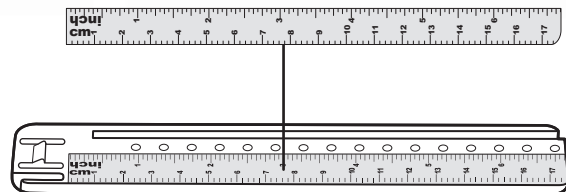

# ASSEMBLY

1a.

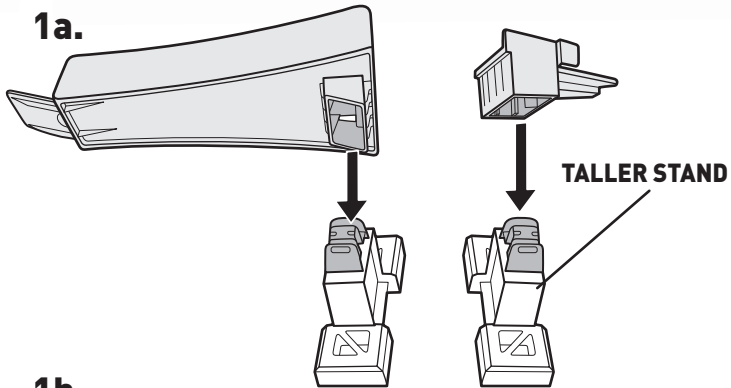

1b.

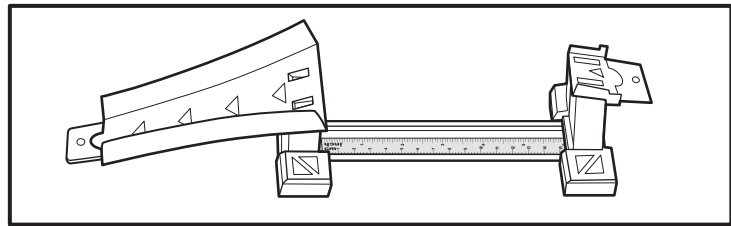
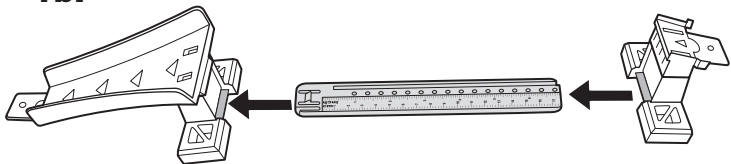

2.

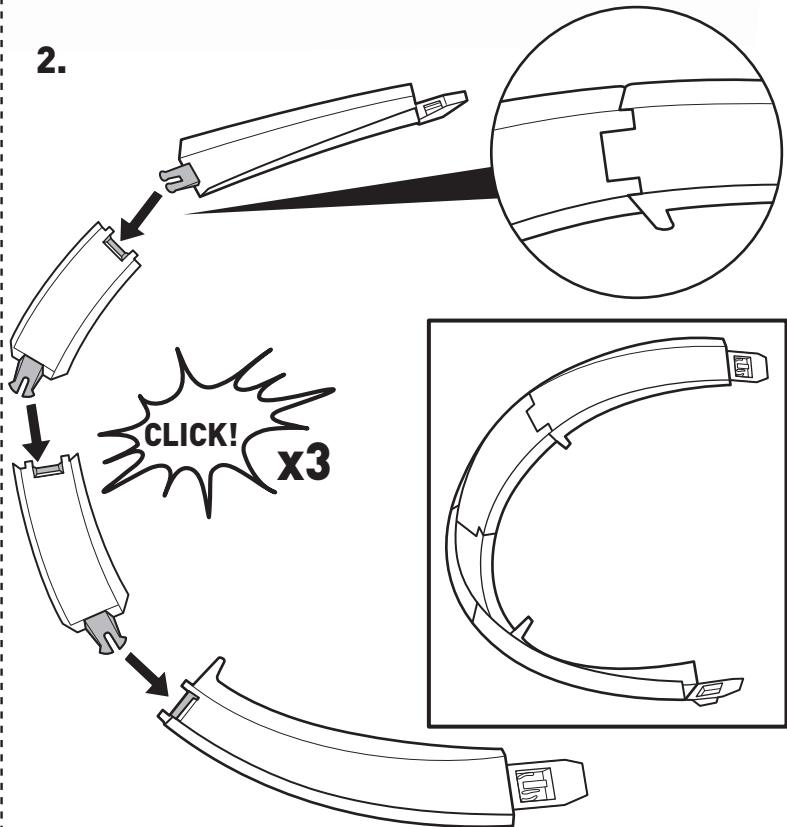

# ASSEMBLY (CONTD.)

3.

10"

12"

12"

18"

CREATE A BANKED CURVE HERE.

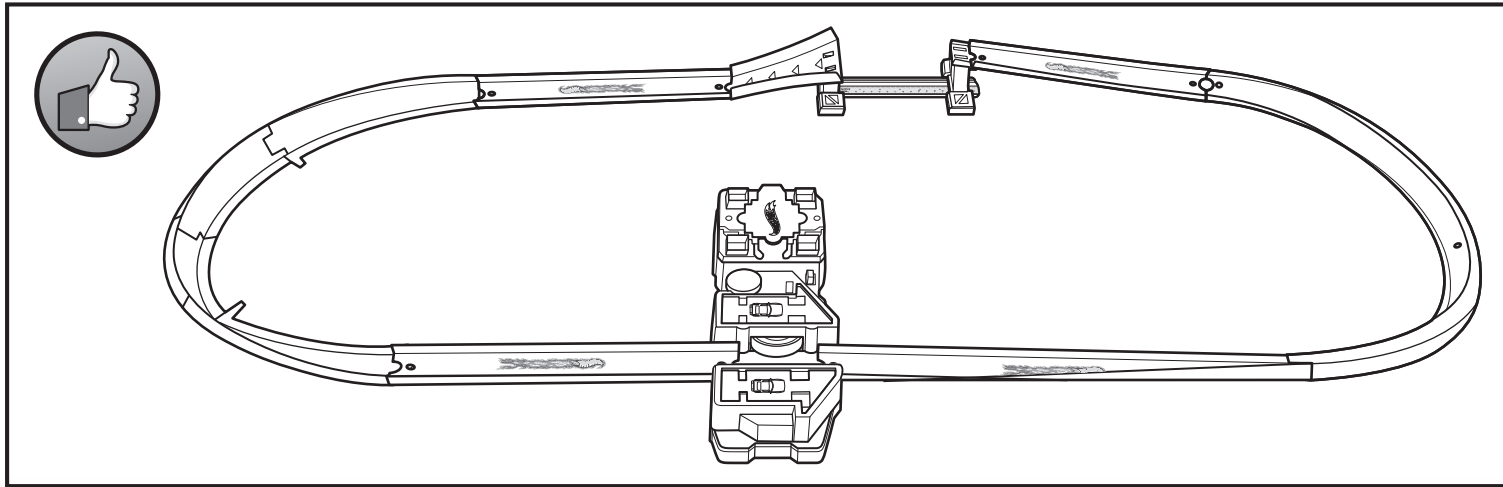

# TO PLAY

## 1. TEST YOUR LIMITS BY ADJUSTING THE JUMP DISTANCE!

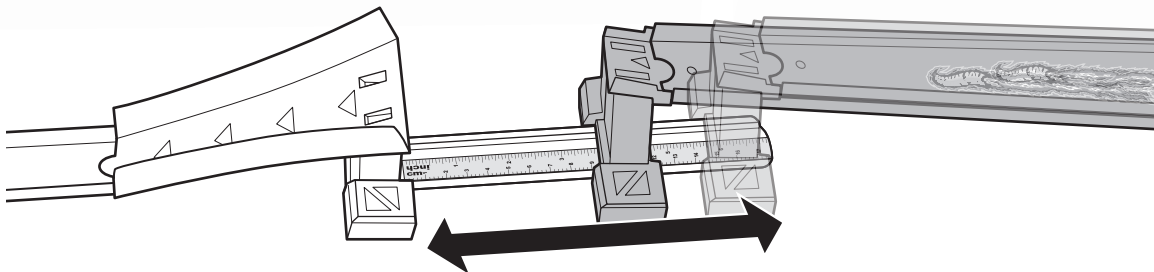

## 2. LOAD CARS IN SPECTATOR ZONES TO CHEER ON THE RACERS!

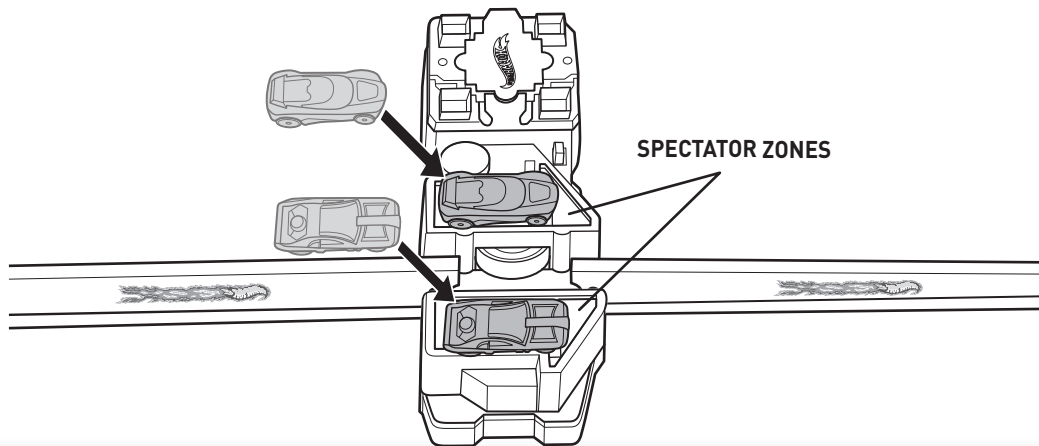

**3. SWITCH ON THE BOOSTER AND PUSH YOUR CAR THROUGH.  
SPEED AROUND THE HOT CURVES AND LAND THE SUPER JUMP!**

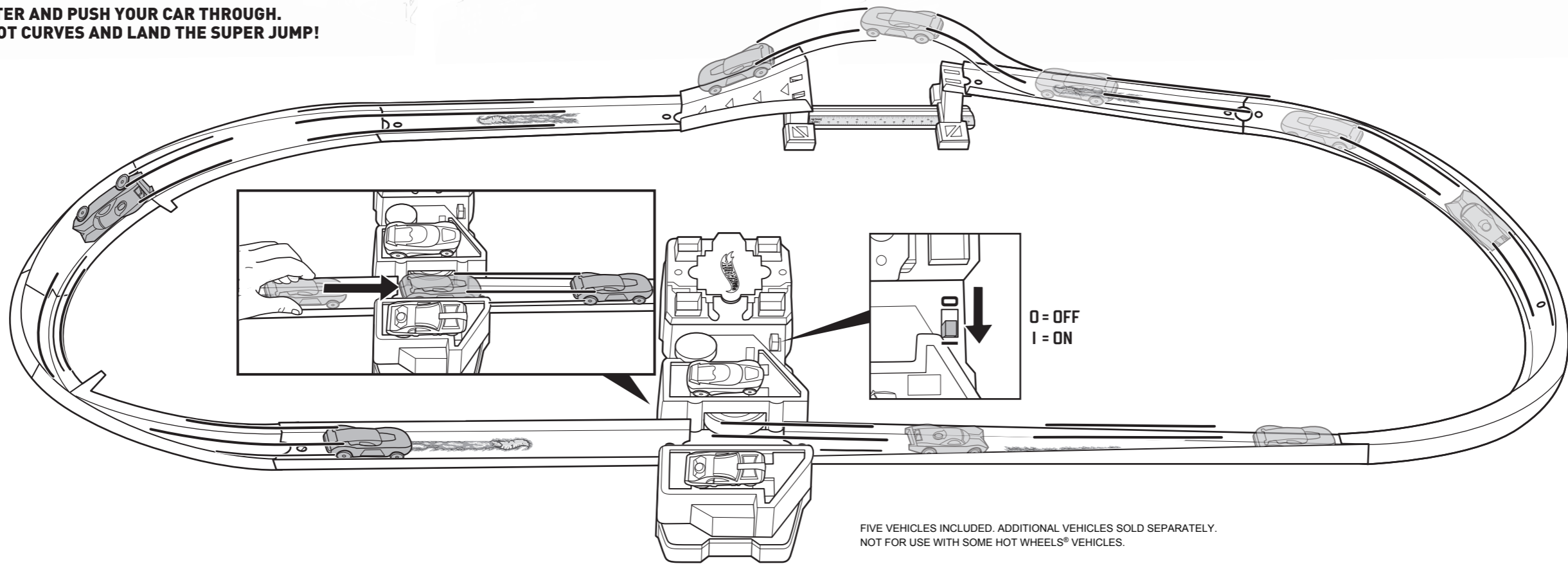

FIVE VEHICLES INCLUDED. ADDITIONAL VEHICLES SOLD SEPARATELY.  
NOT FOR USE WITH SOME HOT WHEELS® VEHICLES.