

PERFORMANCE TIPS

Q. My vehicle keeps slowing down by itself on the track. What is the problem?

A. Lint may collect around your vehicle's axles. This may cause the vehicle to run slowly. Use tweezers or a toothpick to remove lint.

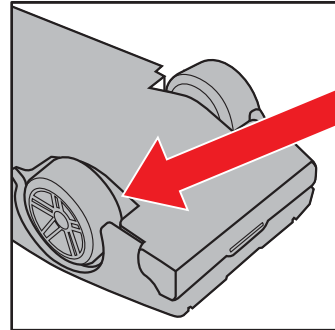

PARENTS: FOR EPIC TRACK IDEAS, HOW-TO VIDEOS AND AWESOME ENTERTAINMENT, CHECK OUT THE HOT WHEELS® YOUTUBE CHANNEL!

WWW.YOUTUBE.COM/HOTWHEELS

You Tube



©2019 Mattel. Mattel, Inc., 636 Girard Avenue, East Aurora, NY 14052, U.S.A. Consumer Services 1-800-524-8697. Mattel U.K. Ltd., Vanwall Business Park, Maidenhead SL6 4UB. Helpline 01628 500303. Mattel Australia Pty., Ltd., Richmond, Victoria. 3121. Consumer Advisory Service - 1300 135 312. Mattel South Africa (PTY) LTD, Office 102 I3, 30 Melrose Boulevard, Johannesburg 2196. Mattel East Asia Ltd., Room 503-09, North Tower, World Finance Centre, Harbour City, Tsimshatsui, HK, China. Tel.: (852) 3185-6500. Diimport & Diedarkan Oleh: Mattel Southeast Asia Pte. Ltd., No 19-1, Tower 3 Avenue 7, Bangsar South City, No 8, Jalan Kerinchi, 59200 Kuala Lumpur, Malaysia. Tel: 03-33419052.

20

HOTWHEELS

INSTRUCTIONS

AGES
6-10

service.mattel.com
HOTWHEELS.COM

PLEASE KEEP THESE INSTRUCTIONS FOR FUTURE REFERENCE AS THEY CONTAIN IMPORTANT INFORMATION.

WARNING:
CHOKING HAZARD - Small parts.
Not for children under 3 years.

GKT87-0970-61
1101951925-00M



RACE CRATE



HOW TO OPEN YOUR BOX:

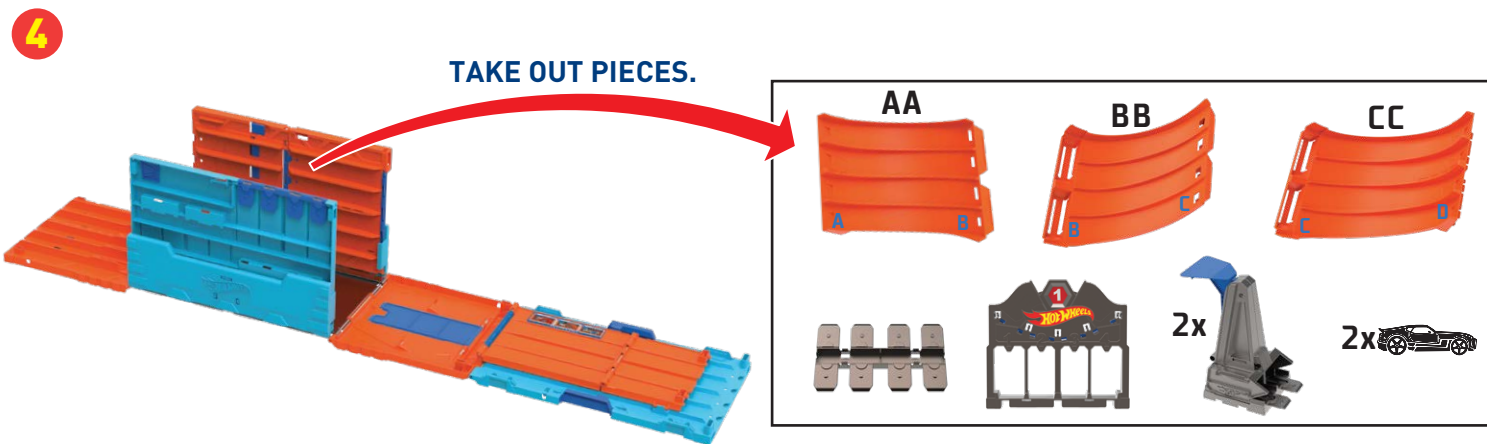
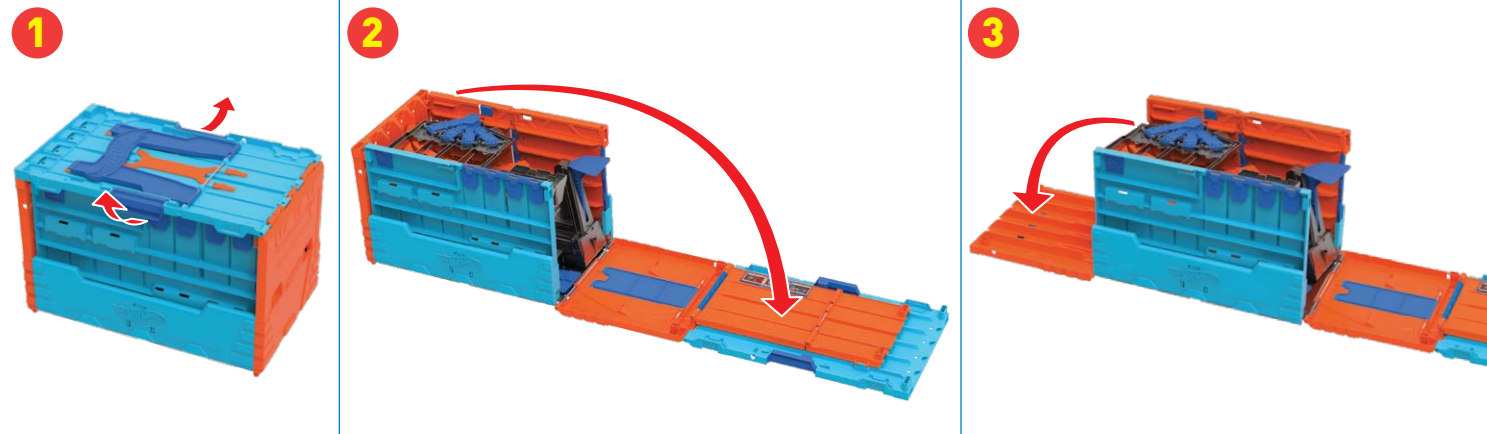

FOR VIDEO INSTRUCTIONS GO TO: www.HotWheels.com/RaceCrate

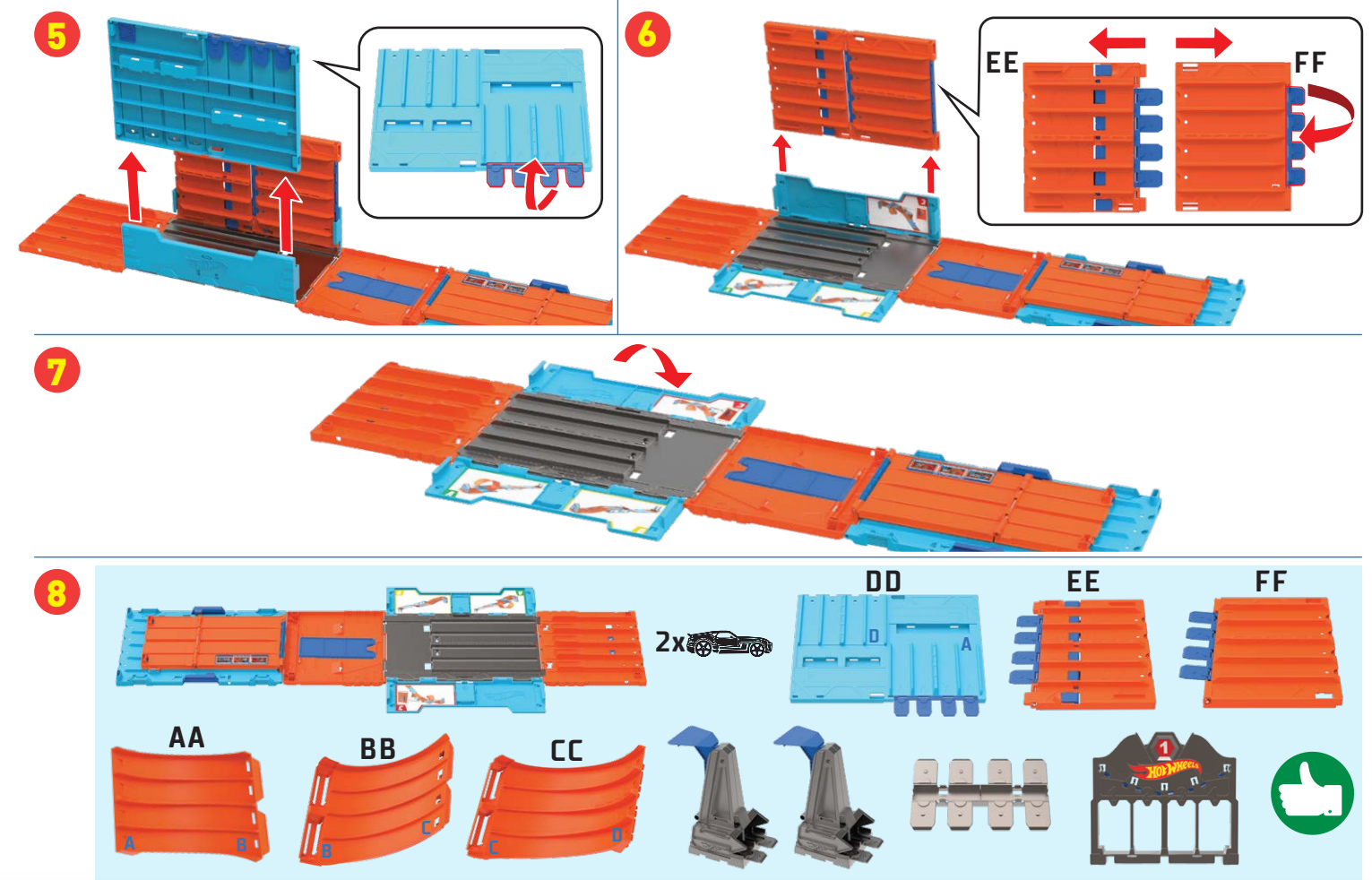

BUILD THESE FIRST:

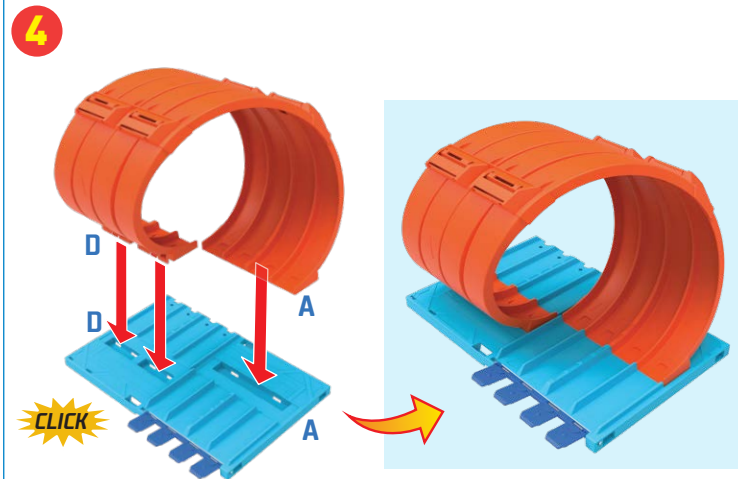
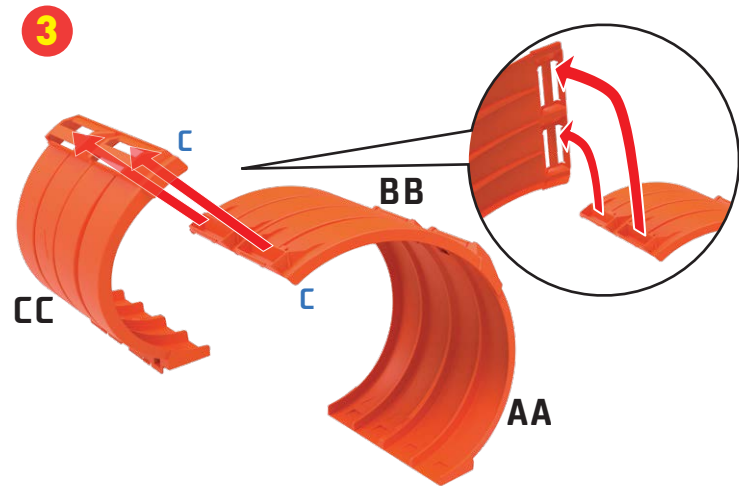
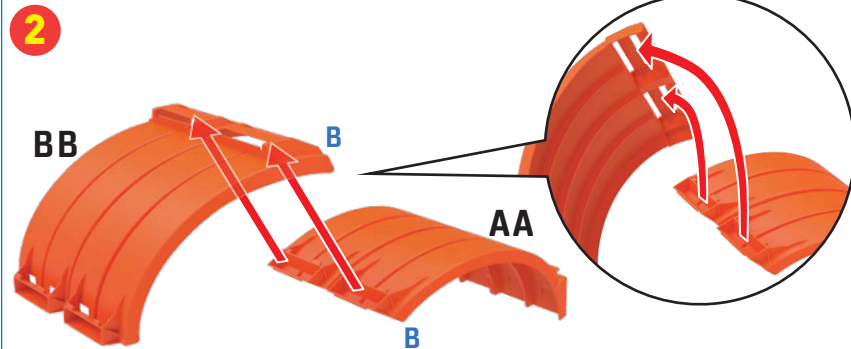
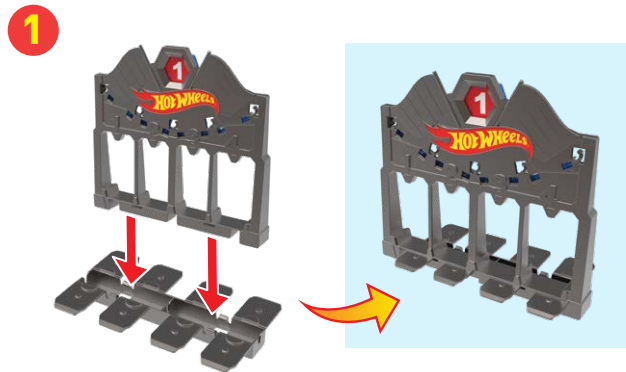

4

WHICH 4-LANE RACEWAY WILL YOU CHALLENGE FIRST?

BUILD A DRAG RACE

INSTRUCTIONS ON PAGE 6

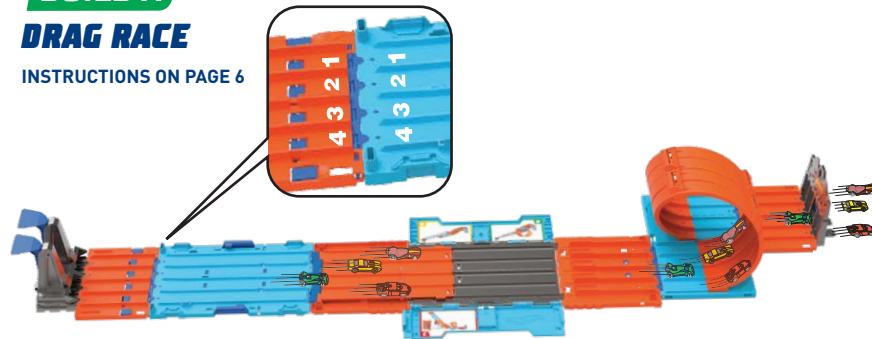

BUILD B HILL CLIMB

INSTRUCTIONS ON PAGE 9



BUILD C GRAVITY DROP

INSTRUCTIONS ON PAGE 12

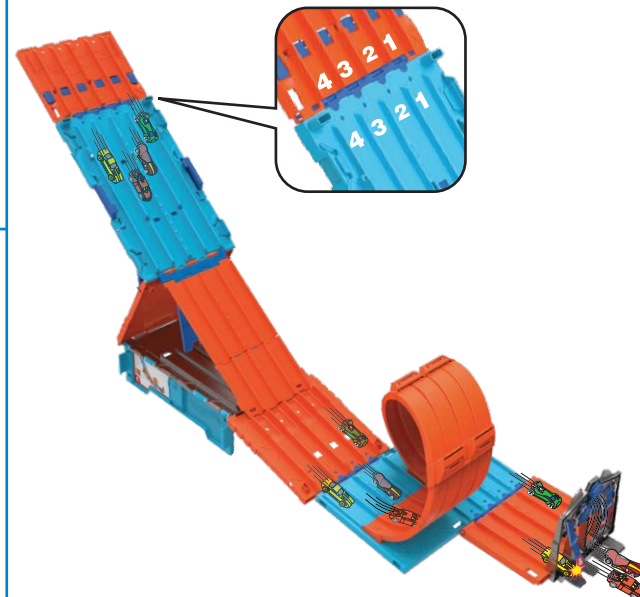

COLORS AND DECORATIONS MAY VARY.
NOT FOR USE WITH SOME HOT WHEELS® VEHICLES.
2 VEHICLES INCLUDED. ADDITIONAL VEHICLES SOLD SEPARATELY.

NOTE: FOR BEST PERFORMANCE, PLAY ON LOW PILE CARPET OR HARD SURFACES.

5

BUILD A: DRAG RACE

HERE'S WHAT YOU NEED:



1

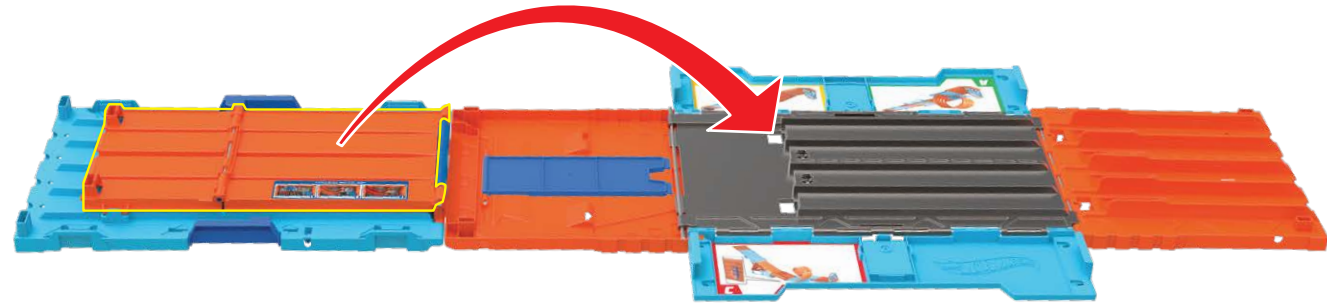

2

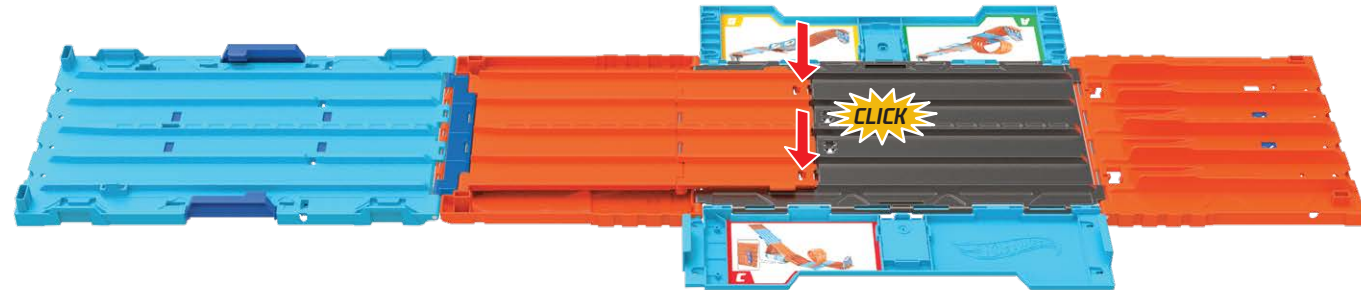

6

3

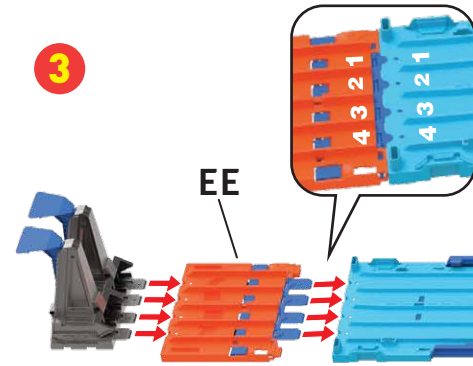

4

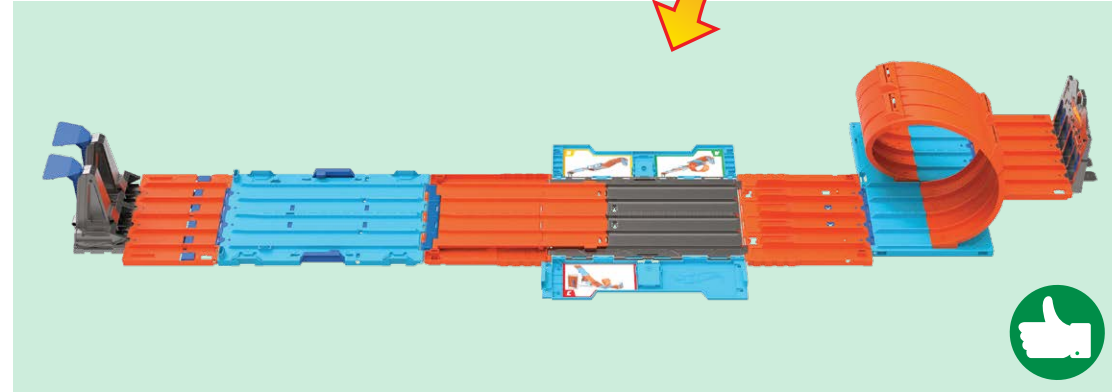
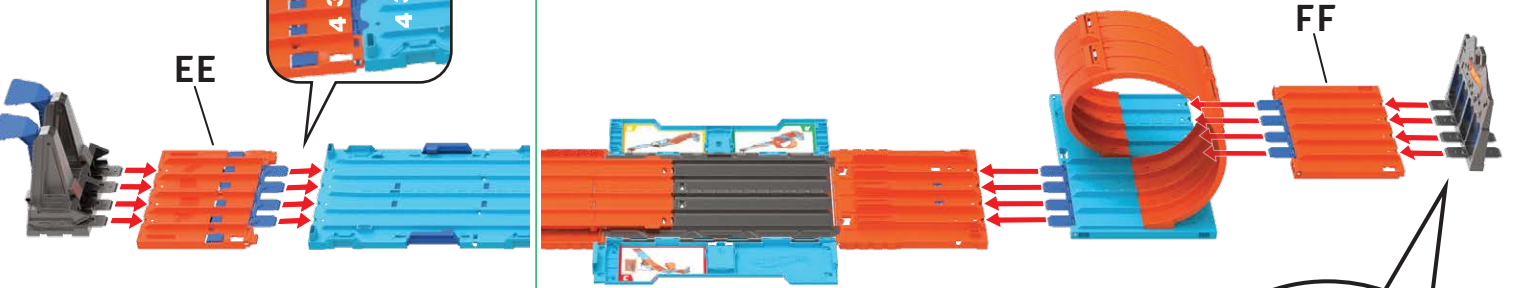

FLIP DOWN FOR EACH RACE.

7

NOW GRAB YOUR CAR AND GO!



BUILD B: HILL CLIMB

HERE'S WHAT YOU NEED:



REFER TO PAGE 4

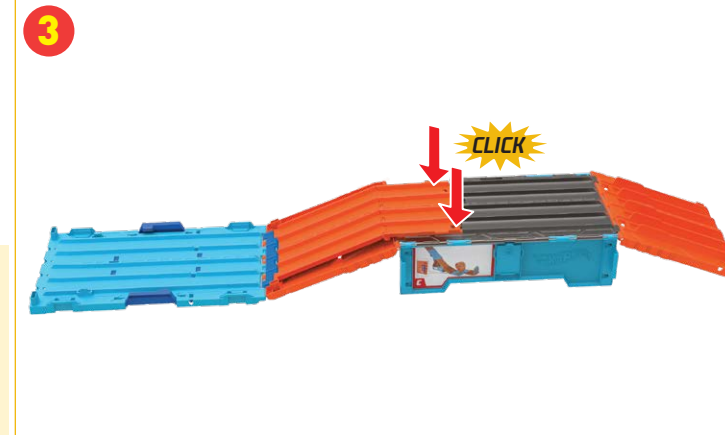
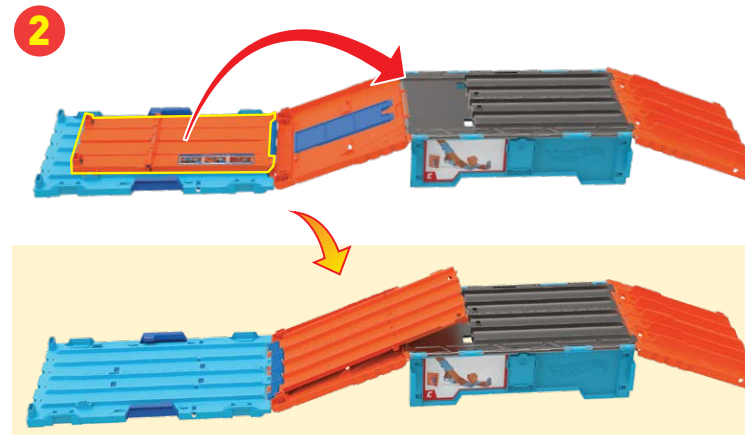
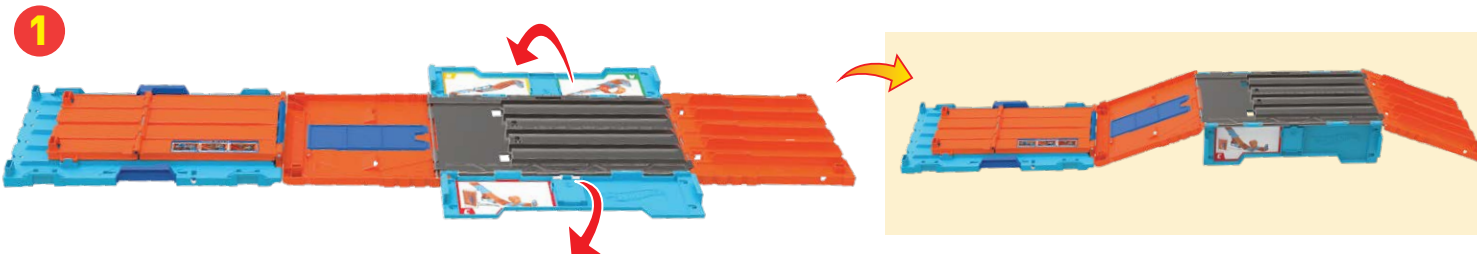

4

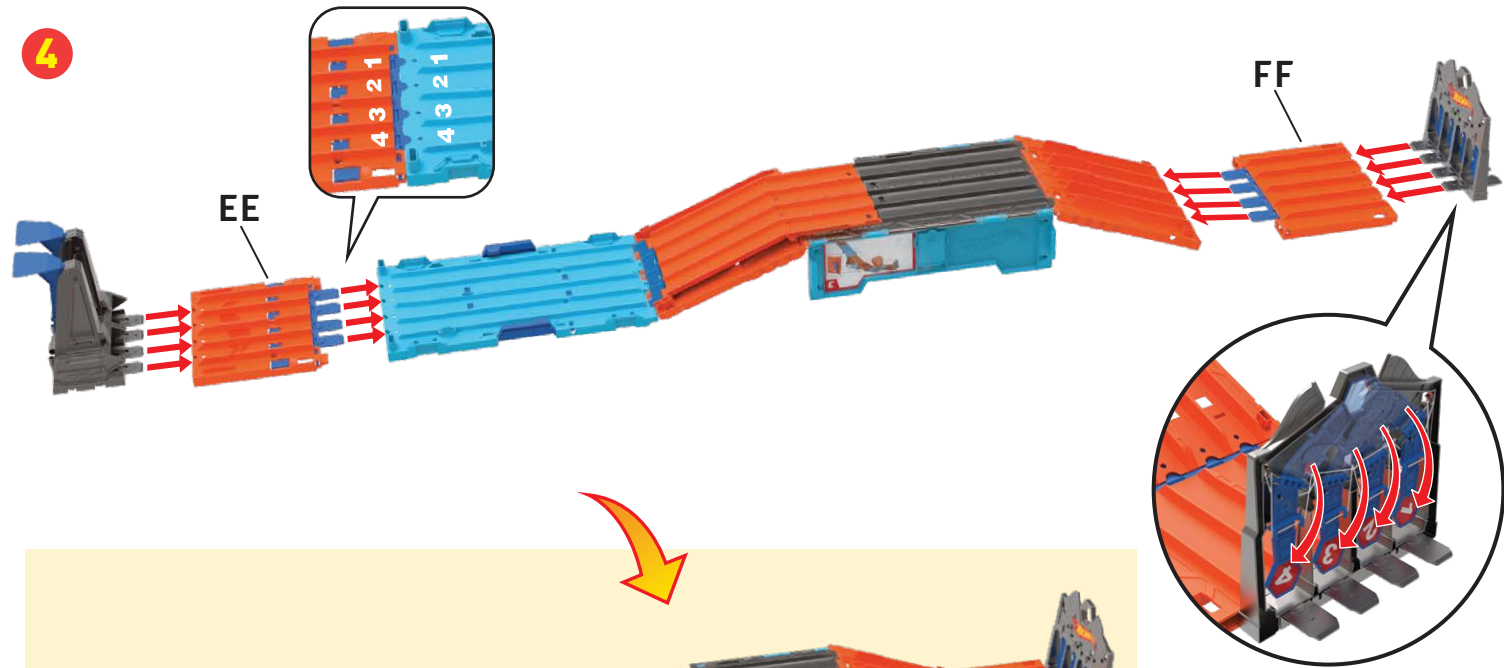

FLIP DOWN FOR EACH RACE.

NOW GRAB YOUR CAR AND GO!



LOAD YOUR CARS & POUND TO LAUNCH!

TIP: INSERT CAR ENTIRELY INTO THE LAUNCHER FOR BEST PERFORMANCE.



**RACE UP THE RAMP TO JUMP & NAIL THE LANDING!
CAN YOU ALL STAY ON TRACK TO THE FINISH LINE?**

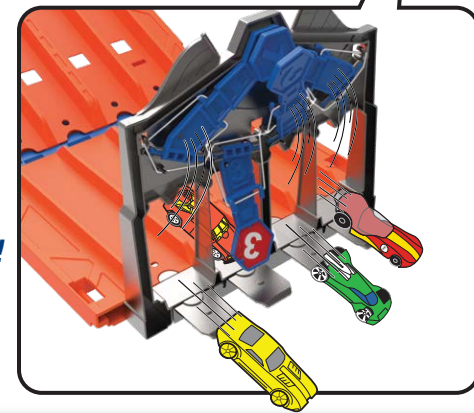

BUILD C: GRAVITY DROP

HERE'S WHAT YOU NEED:



REFER TO PAGE 4

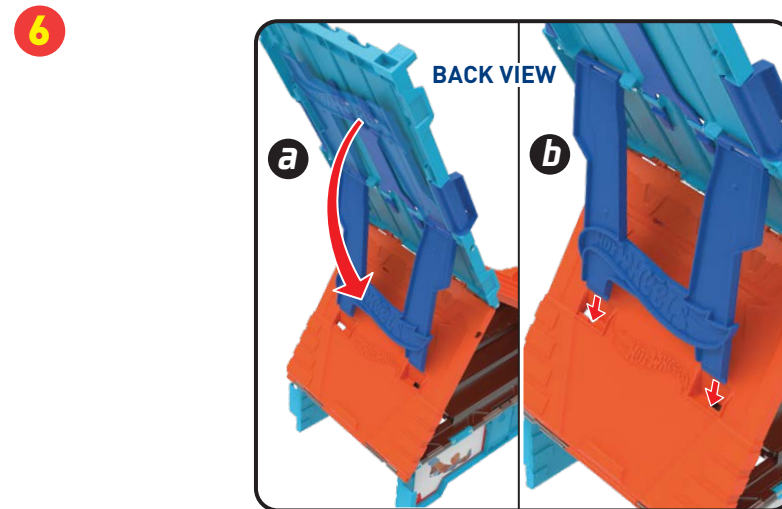
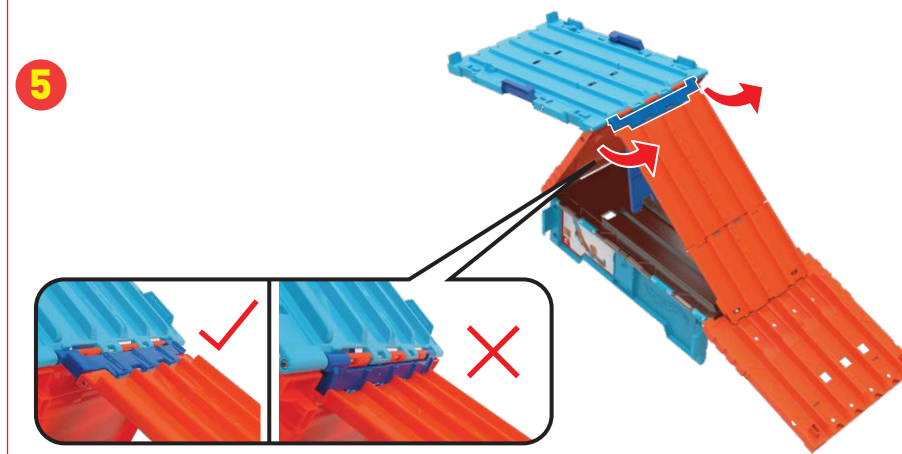
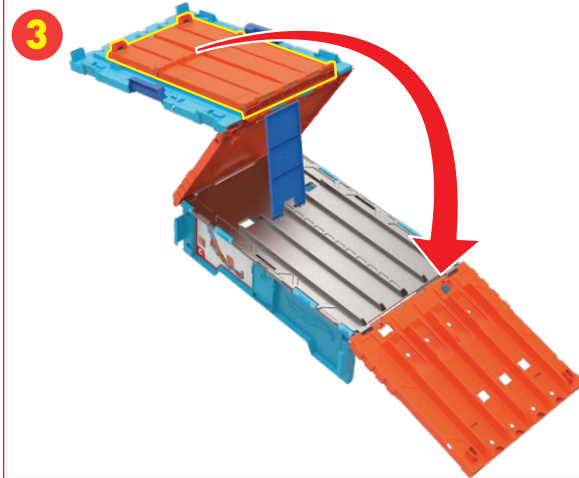
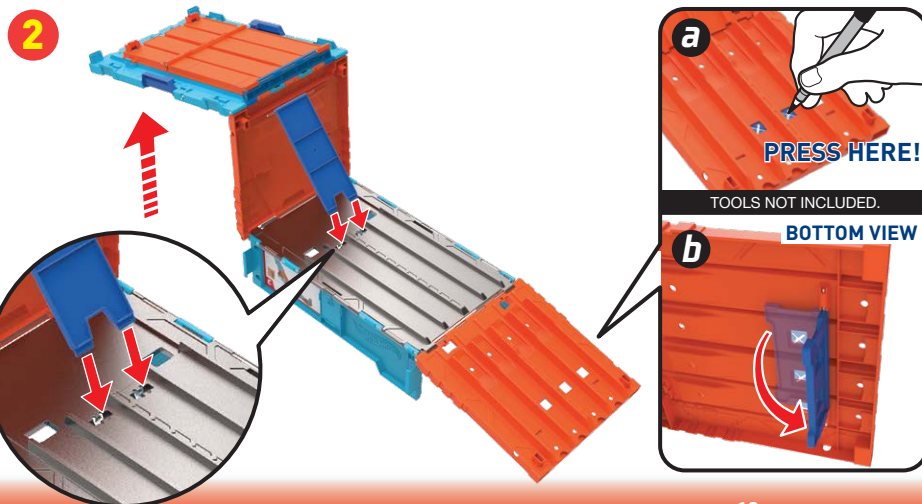
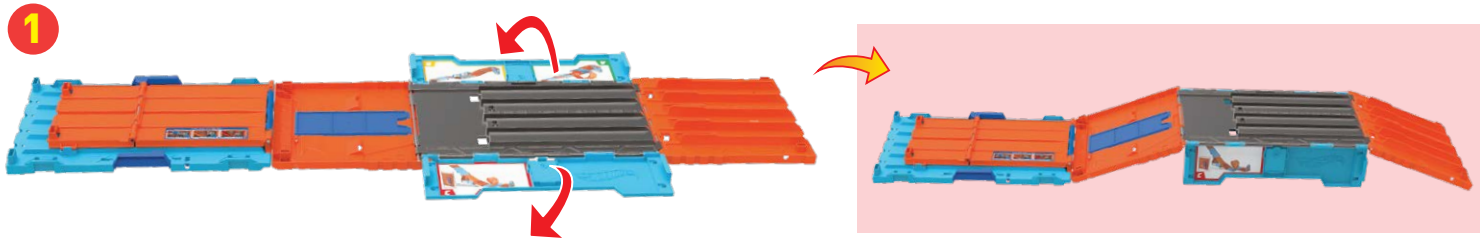
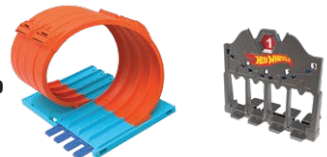

7

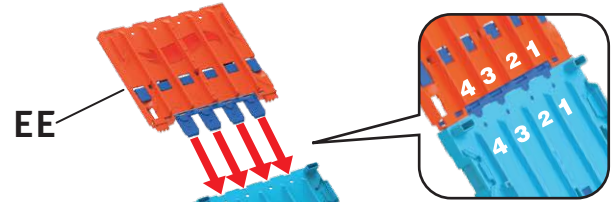

EE

FLIP DOWN FOR EACH RACE.



FF

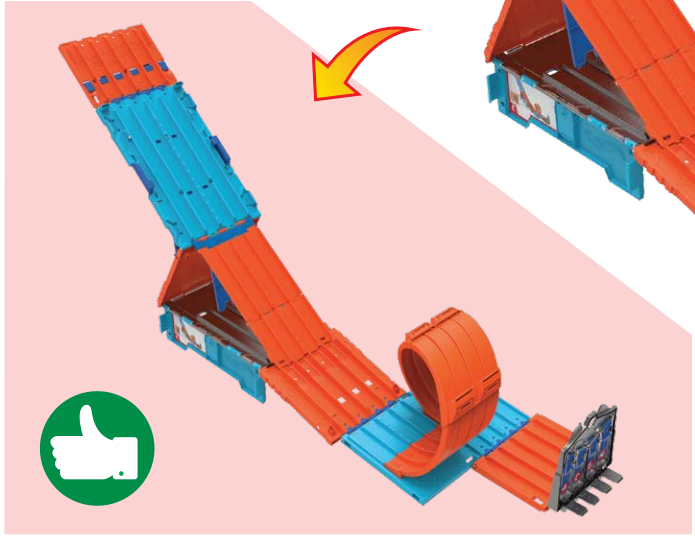

NOW GRAB YOUR CAR AND GO!

LOAD YOUR CARS & LOWER THE GATE FOR A FAIR START!

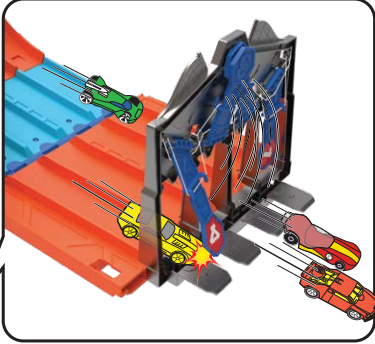

EXPERIENCE THE PULL OF GRAVITY!
WHO CAN MAKE IT THROUGH THE LOOPS & FINISH THE RACE?

HOW TO STORE YOUR PIECES:

1

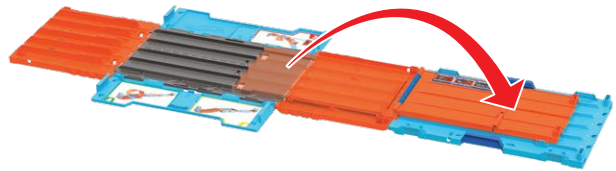

2

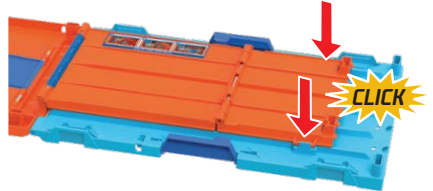

3



4

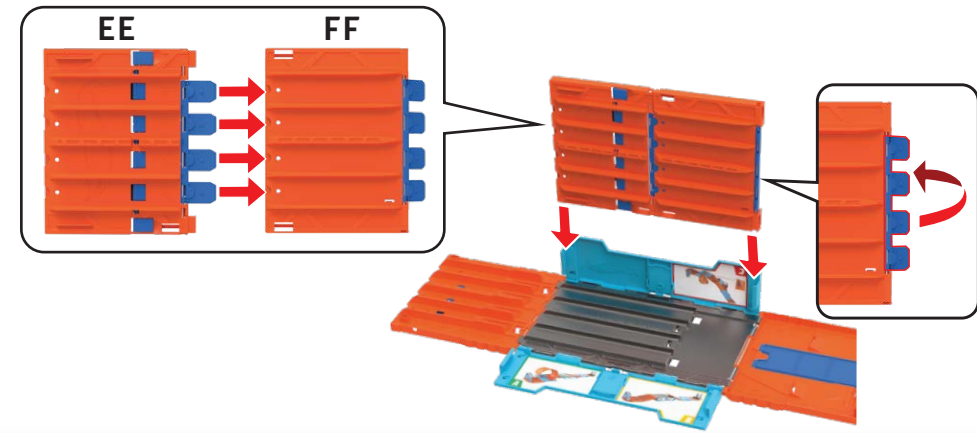

5

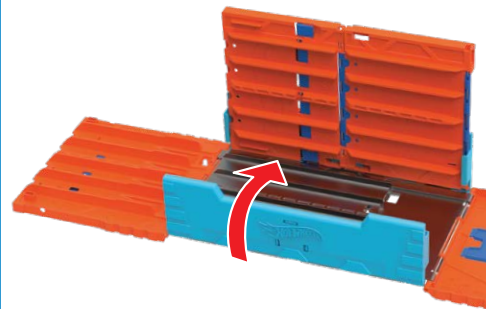

6

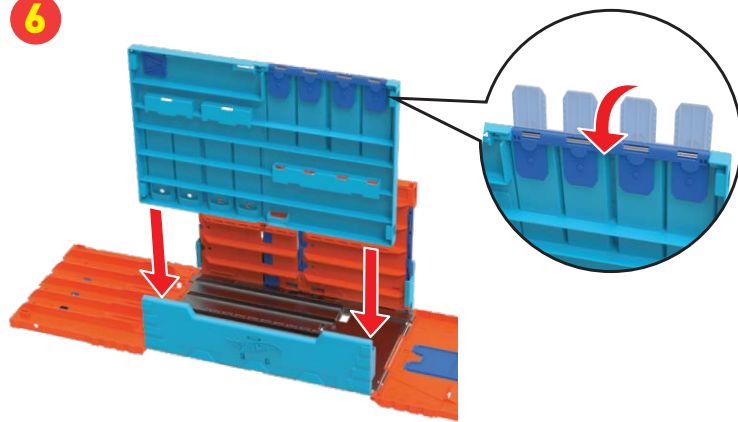

7

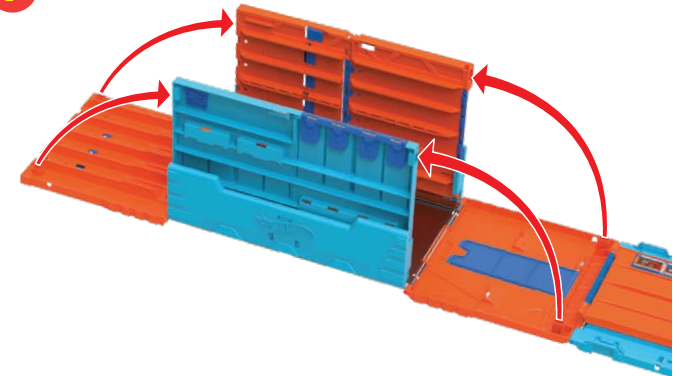

8

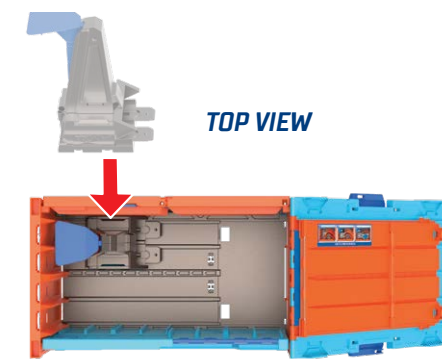

9

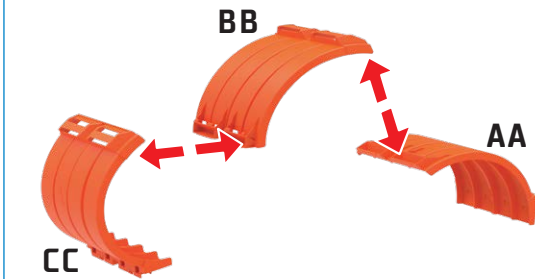

10

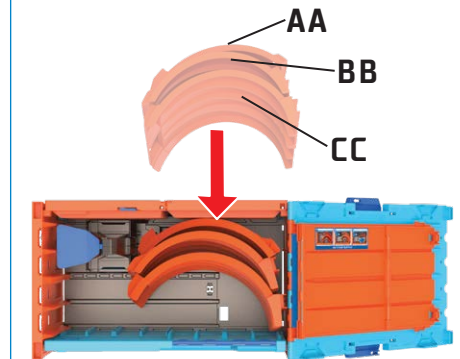

11

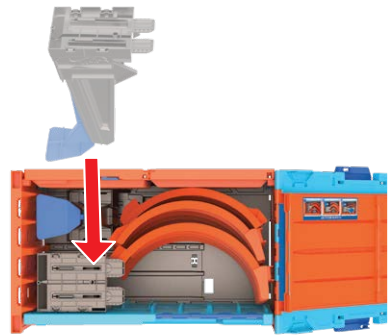

12



13

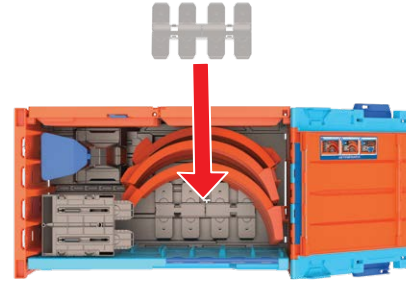

14

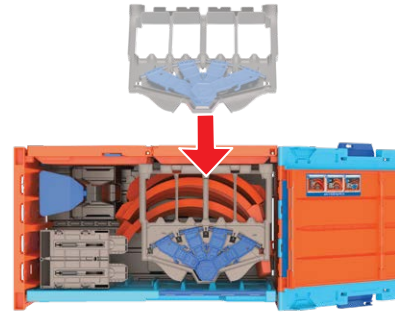

15

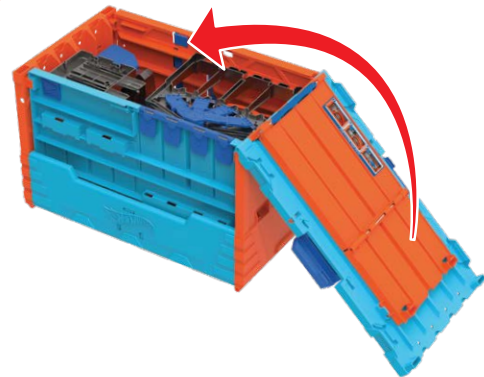

16

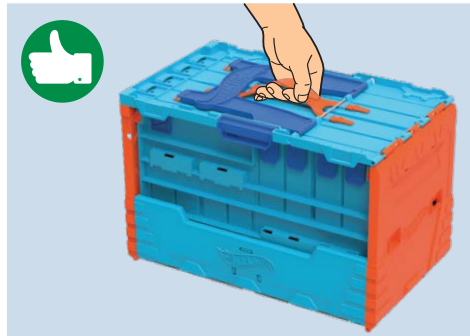
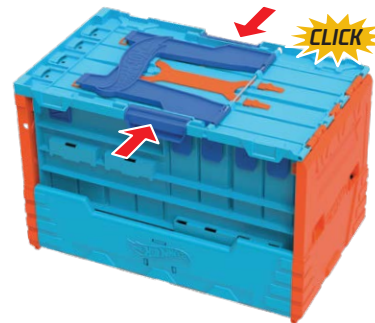

REPLACE RUBBER BAND



FOLLOW THE STEPS IF RUBBER BANDS DETACH.

1

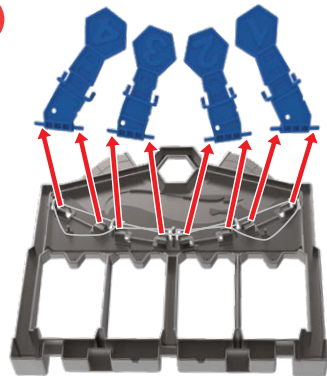

2

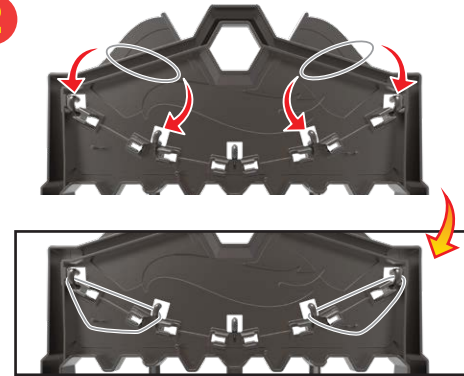

3

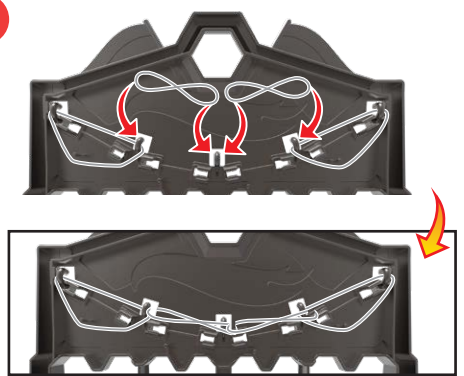

4

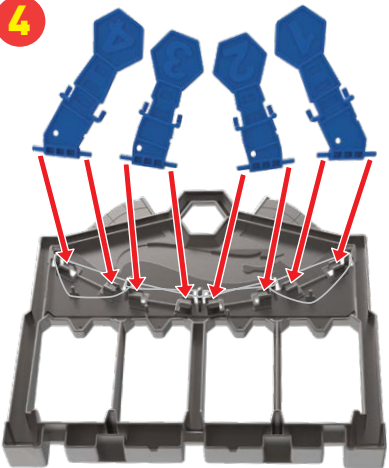

5

