

MEGA
CONSTRUX

HALO

HALO INFINITE

GNB24



2 in 1
EM / B



*Instructions included for main model only. Other build(s) can be found at megaconstrux.com / Instructions incluses pour le modèle principal uniquement.
Les instructions pour l'(les) autre(s) modèle(s) de construction se trouvent sur le site megaconstrux.com



megaconstrux.com

Scan here for instructions
Scanner ici pour obtenir
les instructions

Escanee aquí para obtener instrucciones
Digitalize aqui para instruções
Hier scannen und Anleitung aufrufen
Просканируйтездесь для
получения инструкций

Choose your Build
Choisissez votre construction

Elije tu armado • Escolha sua montagem
Wähle dein Modell • Выбери свою конструкцию

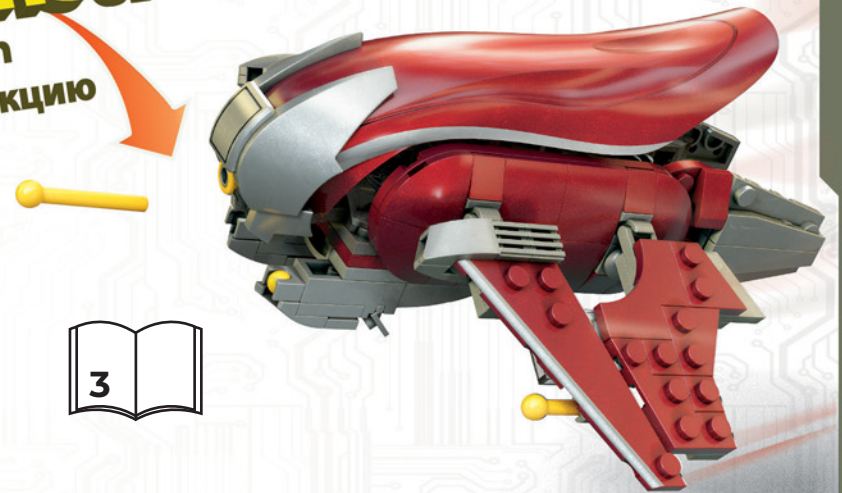

Most models can be built one at a time. / La plupart des modèles peuvent être construits un à la fois. / La mayoría de modelos se pueden construir de uno en uno. / A maioria dos modelos pode ser construída separadamente. / La maggior parte dei modelli possono essere realizzati uno per volta. / Die meisten Modelle können eines nach dem anderen gebaut werden. / Większości modeli nie da się budować jednocześnie z innymi. / De meeste modellen kunnen één voor één gebouwd worden. / Большинство моделей могут быть собраны по одной за раз. / De fleste modeller kan bygges enkeltvis. / De fleste modeller kan bygges en i taget. / De fleste modellene kan bygges en om gangen. / Useimmat mallit voidaan rakentaa yksi kerrallaan. / Τα περισσότερα μοντέλα μπορούν να κατασκευασθούν ένα ένα. / Modellerin çoğu ayrı ayrı inşa edilmeyi gerektirebilir. / Většinou lze najednou sestavit pouze jeden model. / Vážšina modelov môže byť zostavená iba raz. / A modellek többségéből egyszerre csak egy építhető. /ほとんどのモデルは、一度に一つを組み立てることができます。 / يمكن تركيب التصميم الواحد تلو الآخر.

大多數型號可一次性建構

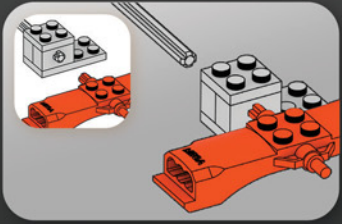
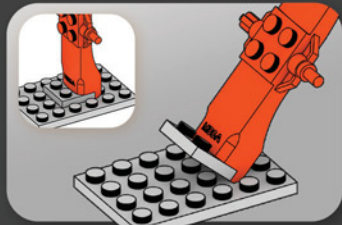

Building Tool Outil de construction

Herramienta de construcción
Bauwerkzeug
Ferramenta de montagem
Инструмент для конструирования

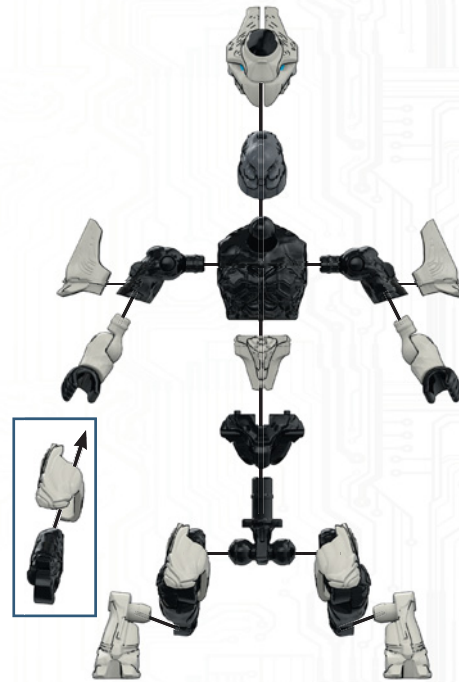
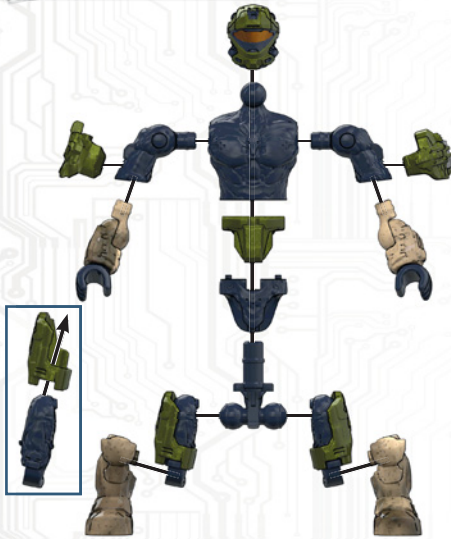
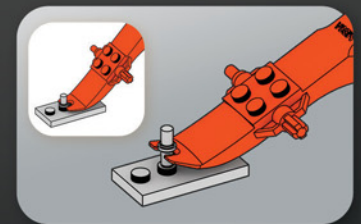
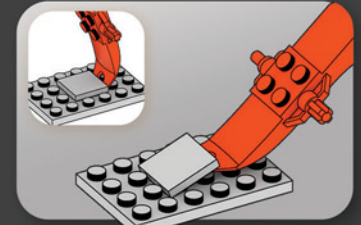

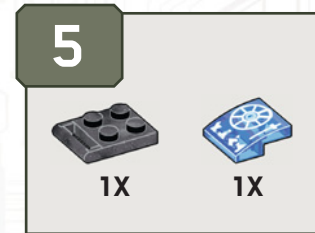
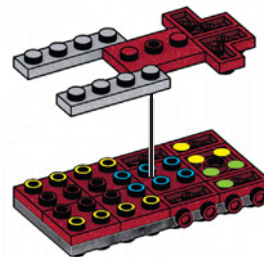
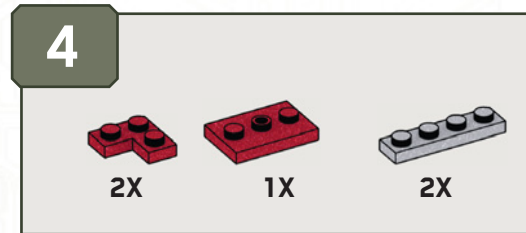
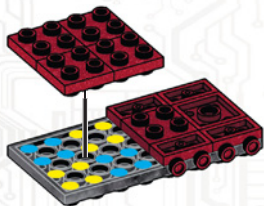
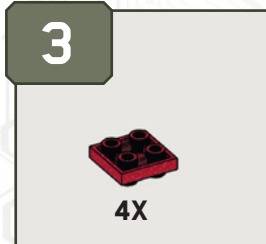
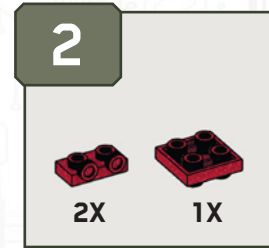
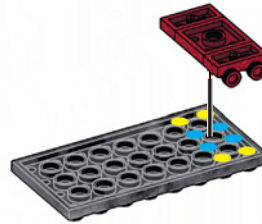
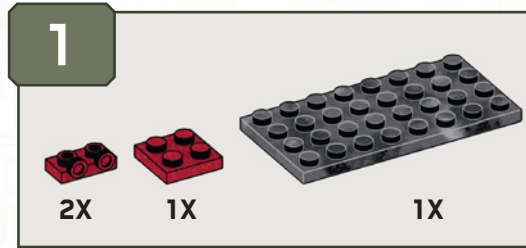

1

2

6



1X

1X



7



2X

2X



8



2X

2X

2X

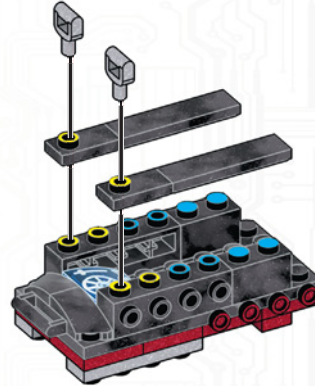

1

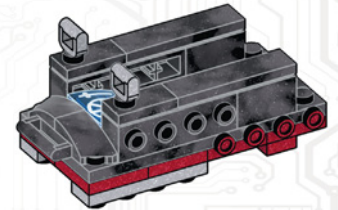

2

9



2X

2X

2X

2X



x2

10

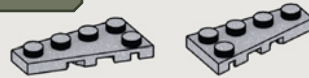

2X

2X

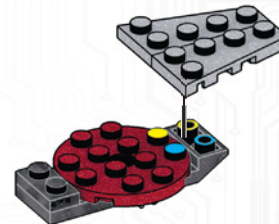

x2

11



2X

2X

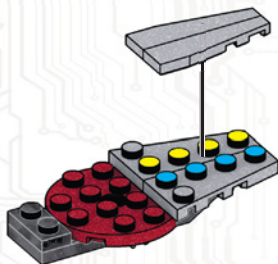

x2

12



4X

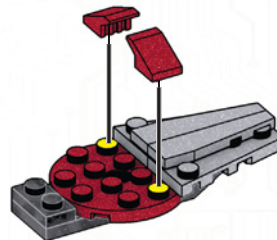

1

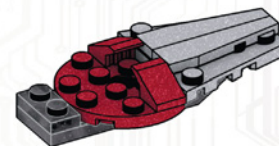

2

x2

13



2X



4X



4X



2X

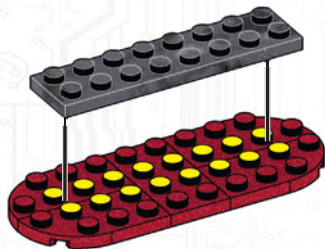

x2

14



4X



4X



4X

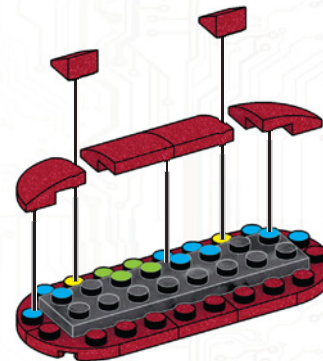

x2

15

4X 4X

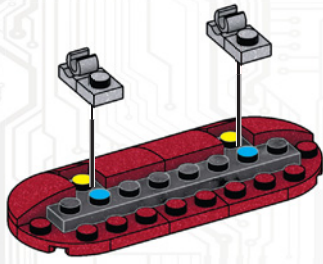

x2

16

4X 4X 4X

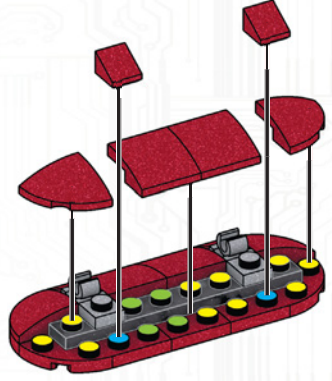

x2

17

4X

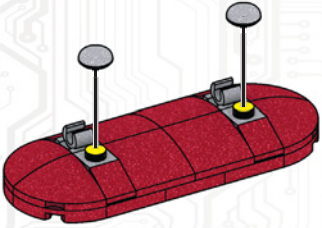

1

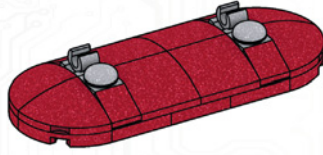

2

x2

18

1X

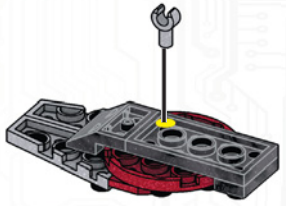

1

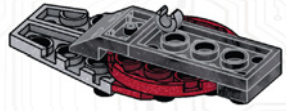

2

19

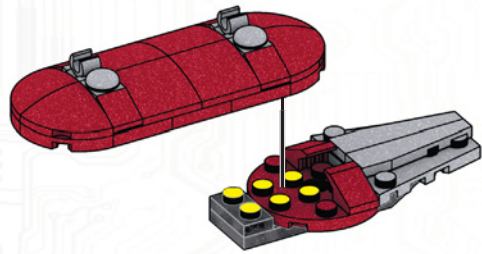

1

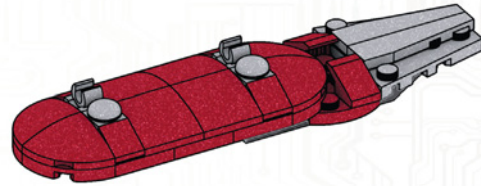

2

20

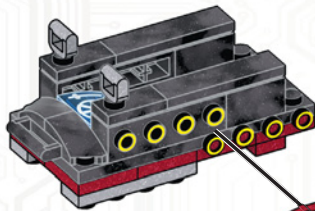

1

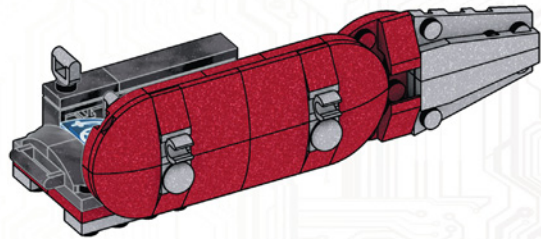
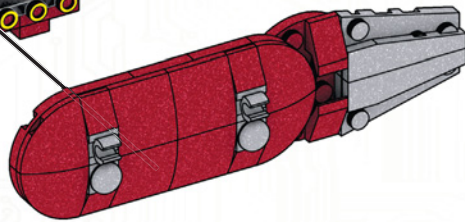

2

21



1X

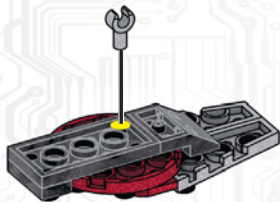

1



2

22

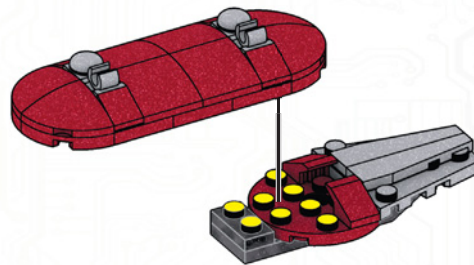

1

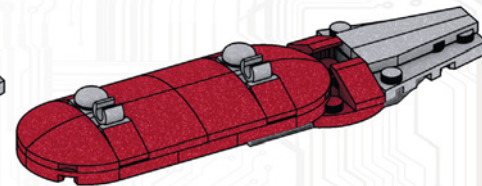

2

23



1X

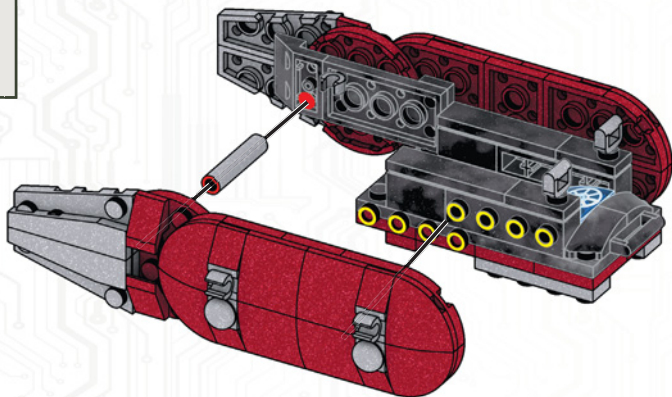

1

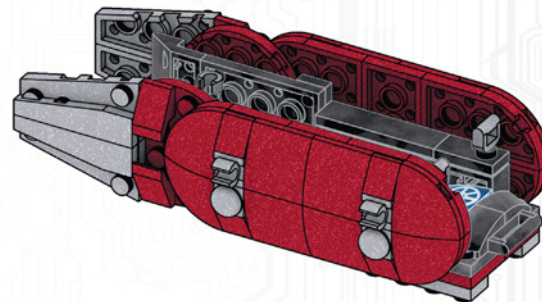

2



24

1X 1X 1X 1X

25

1X 1X

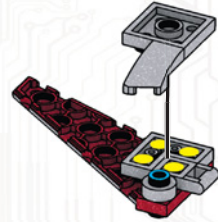
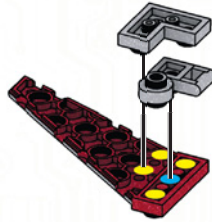

26

1X

27

2X 1X

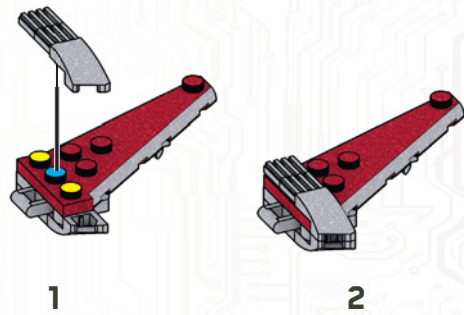
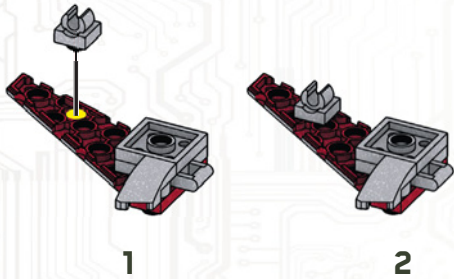

28

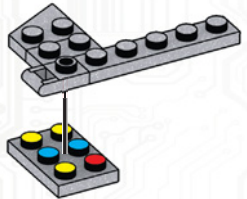

29

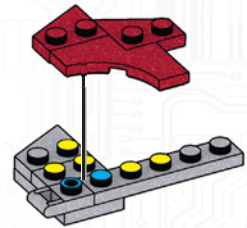

30

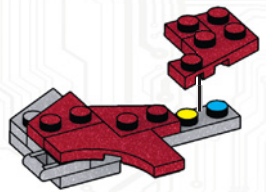
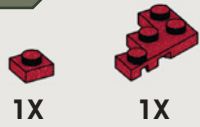

1

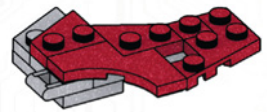

2

31

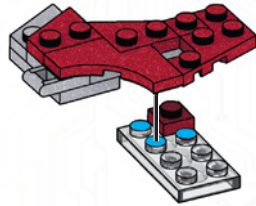
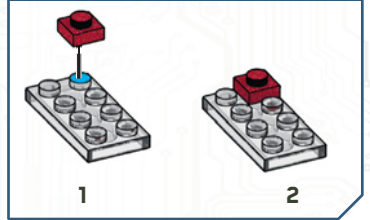

1

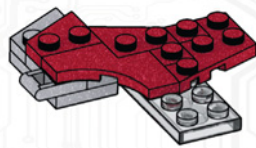

2

32

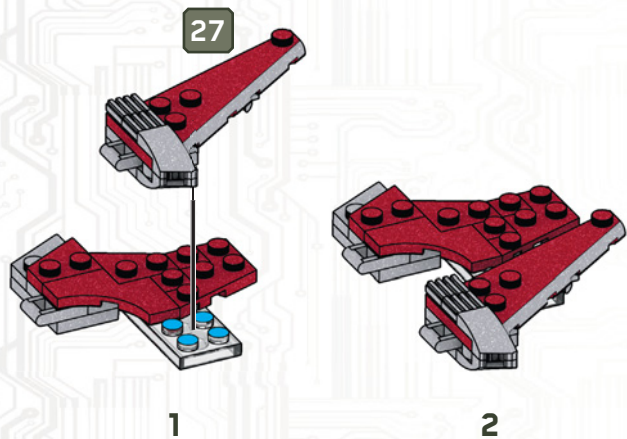

33

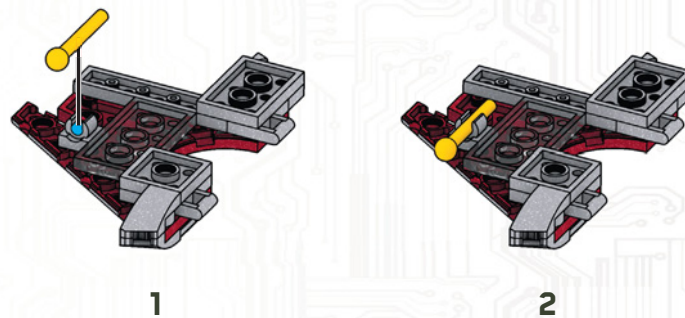

34

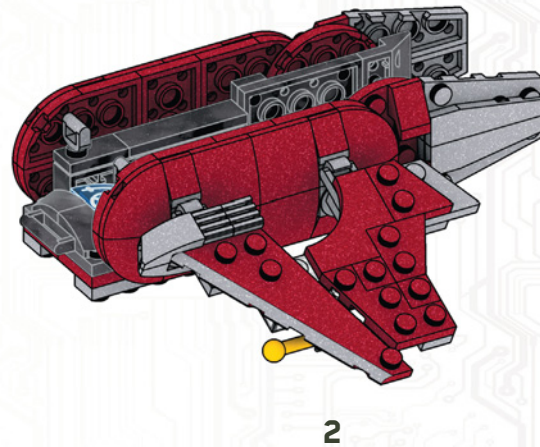
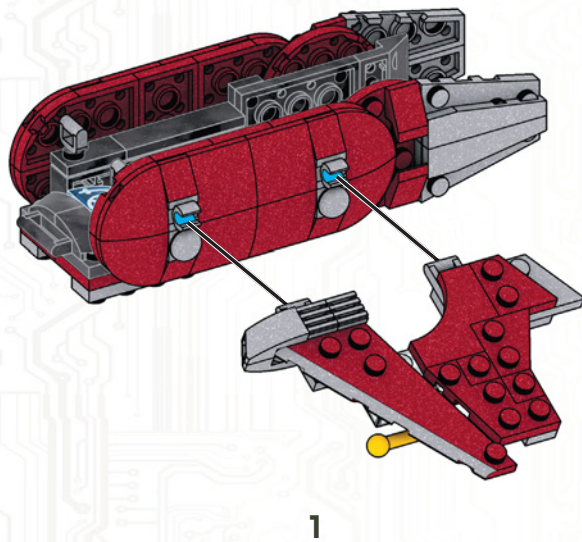

35

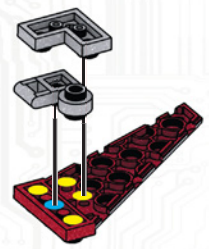
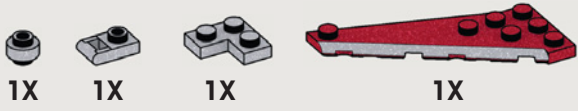

36

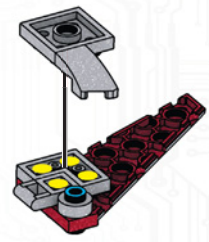
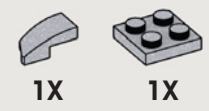

37

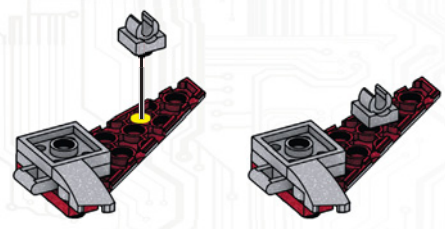

1

2

38

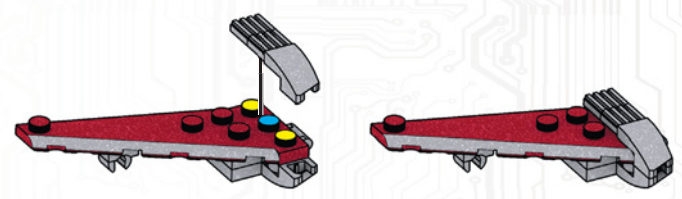

1

2

39

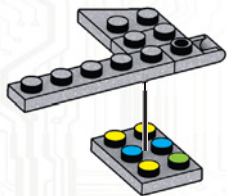
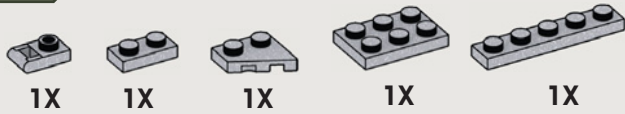

40

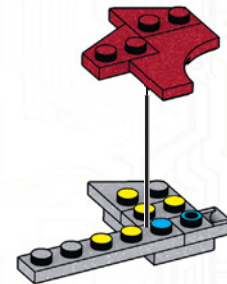

41

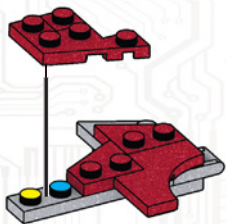

42

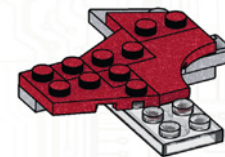
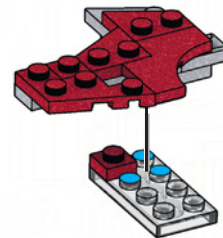
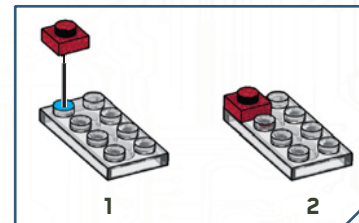

1

2

43

38

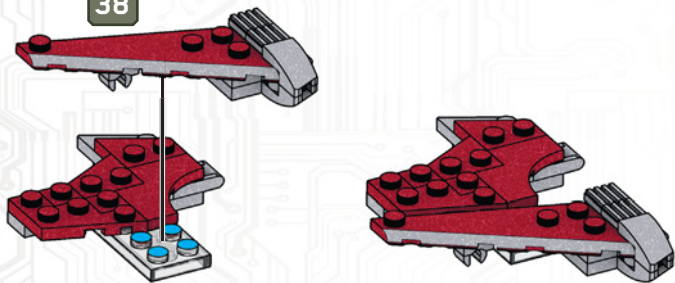

1

2

44



1X

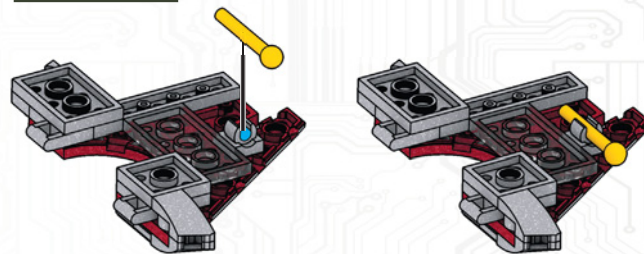

1

2

45

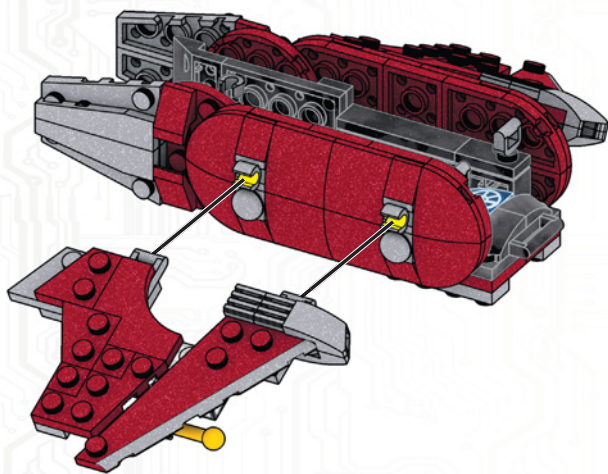

1

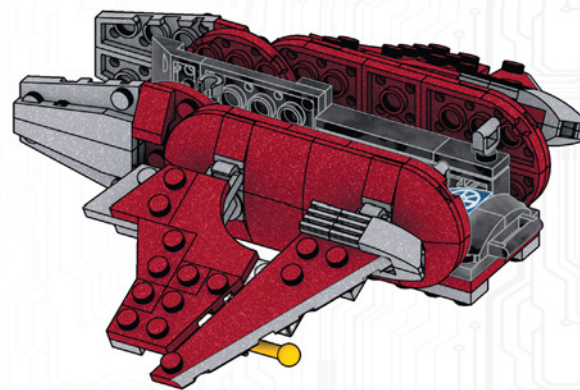

2

46



2X

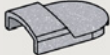

1X

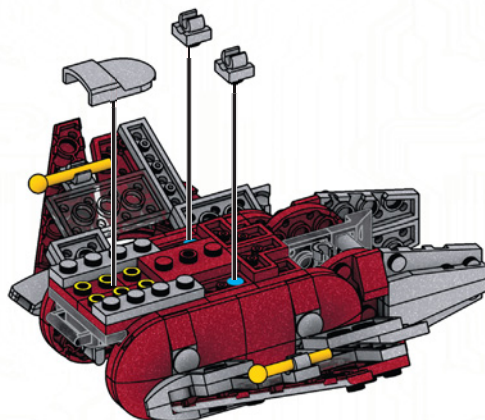

47



2X



2X



2X



1X



1X

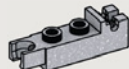

2X



2X

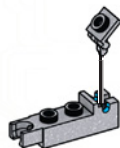

1

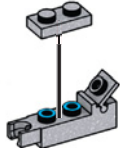

2



3

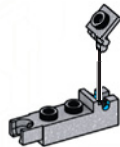

1

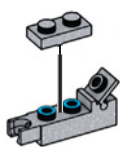

2



3

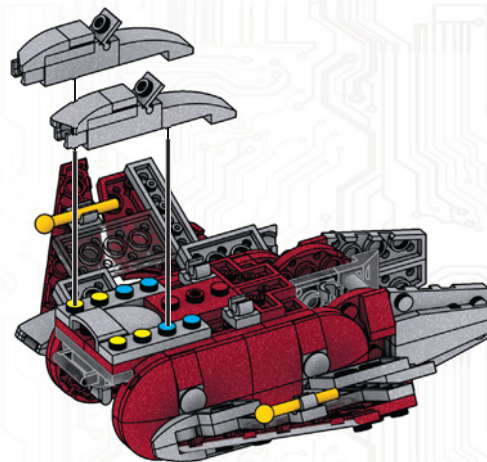

48



2X

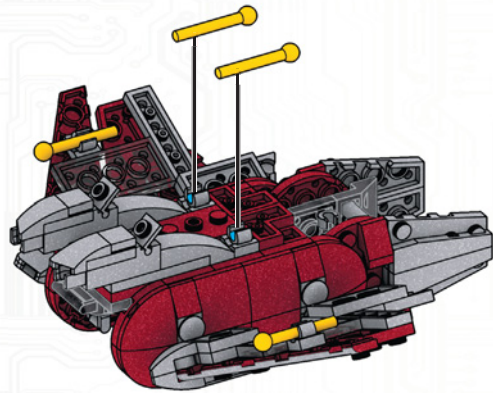

1

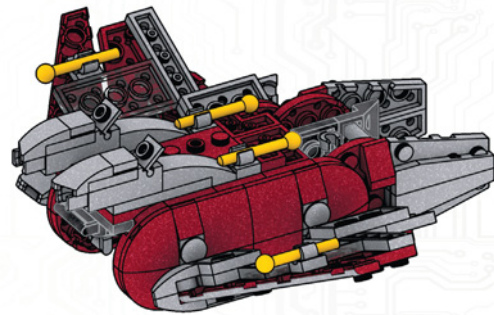

2

49



1X



1X

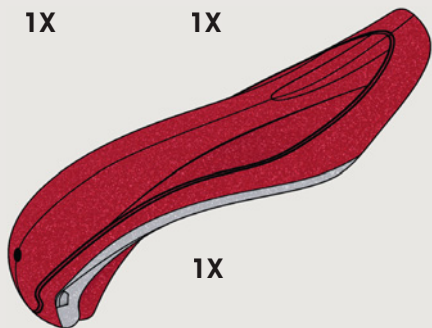

1X

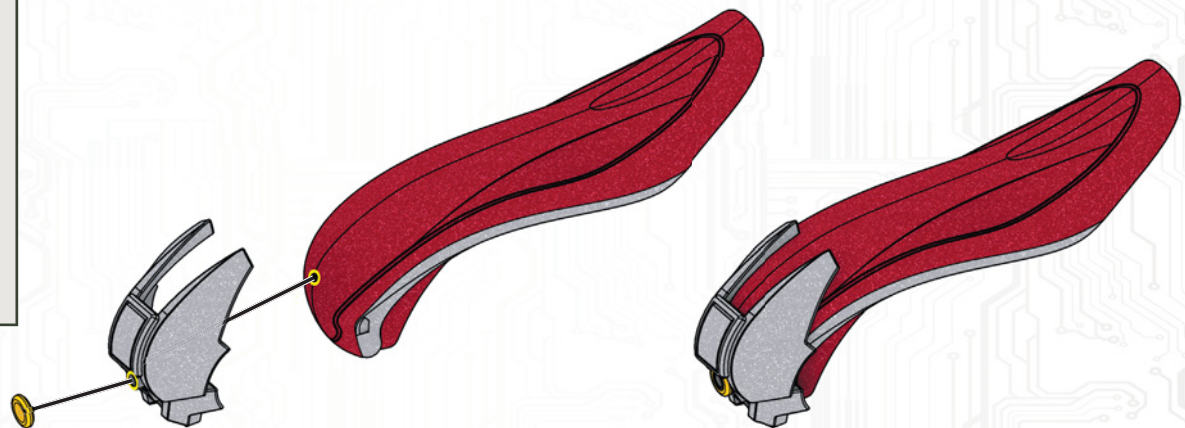

1

2

50



1X

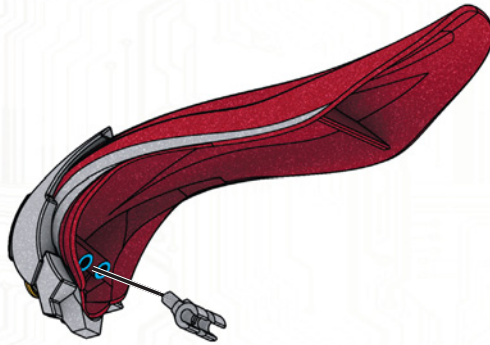

1

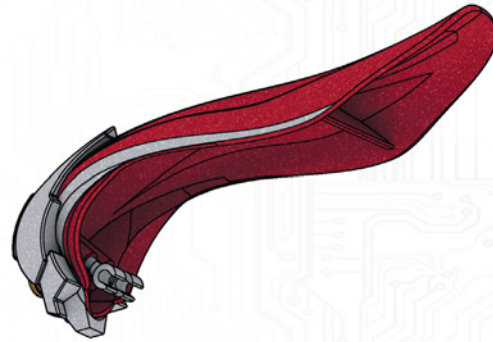

2

51

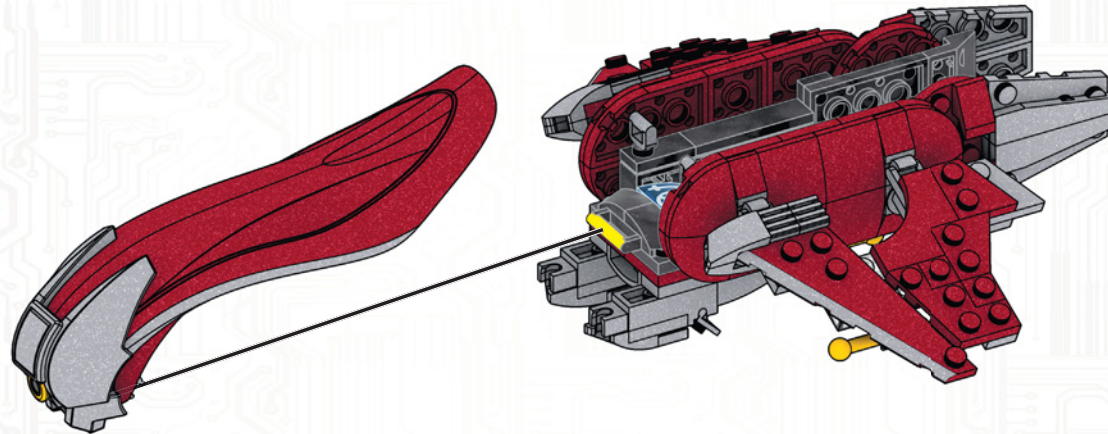

52



2X

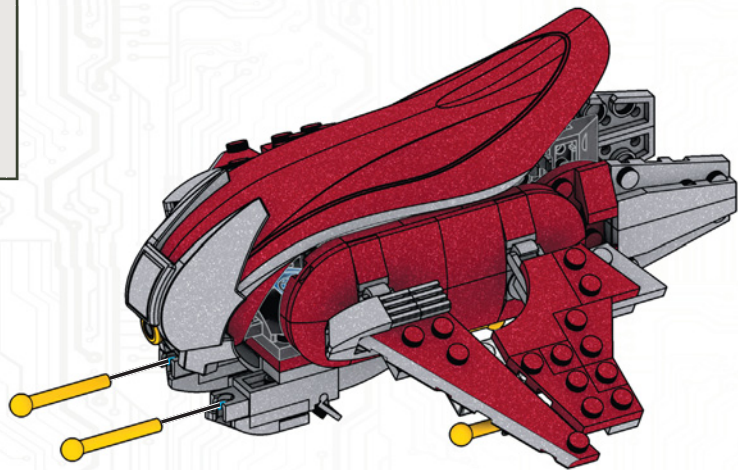

1

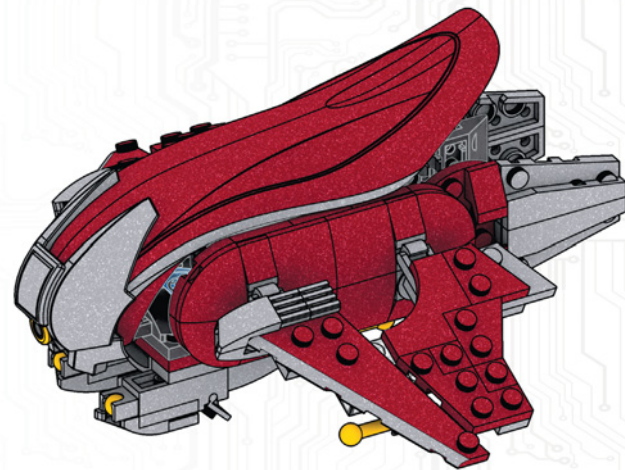

2

53



1X

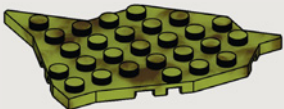

2X



1X

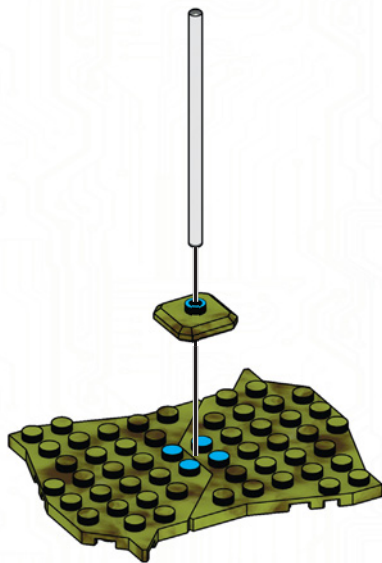

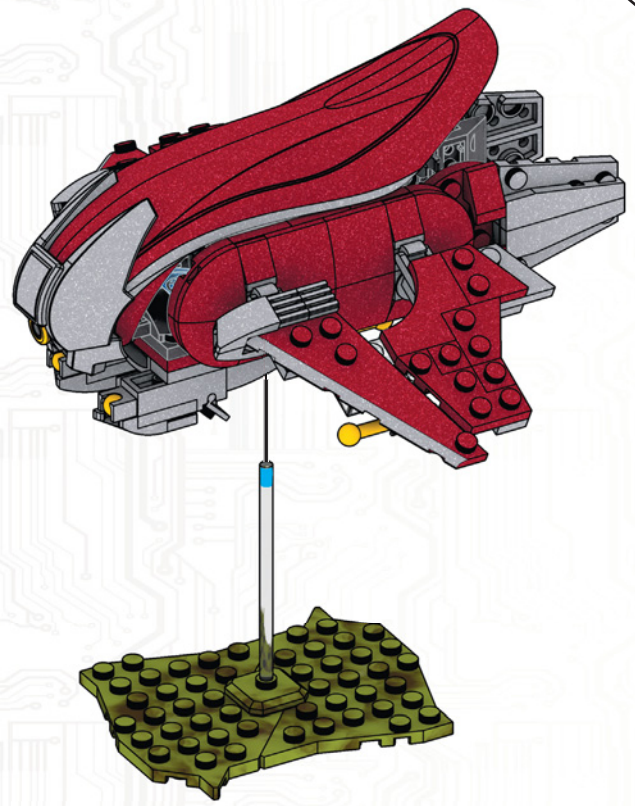
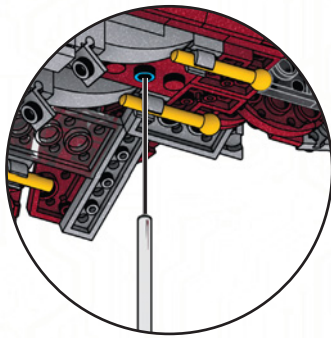

1

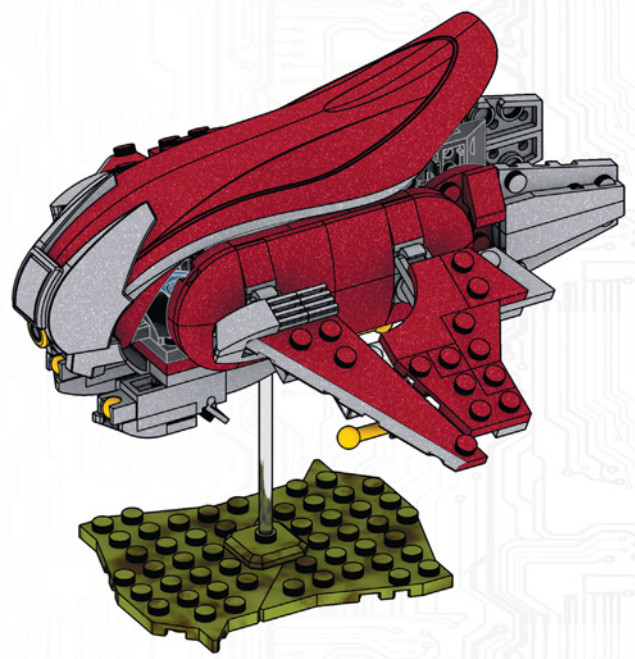

2

Banshee Breakout ■ Évasion en Banshee ■ Estampida de Banshees
 Fuga di Banshee | Die Flucht des Banshee | Ucieczka Banshee | Banshee-ontsnapping
 Прорыв на Banshee | Απόδραση με το Banshee | Banshee Kaçışı | Banshee Szöktetés | Banshee-flykt
 Banshee-pako | Flugt i en Banshee | Ucieczka Banshee | Prielom Banshee | هروب Banshee

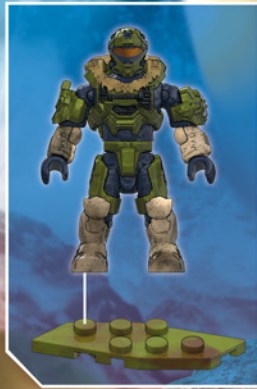

SPARTAN RECON



ELITE ULTRA

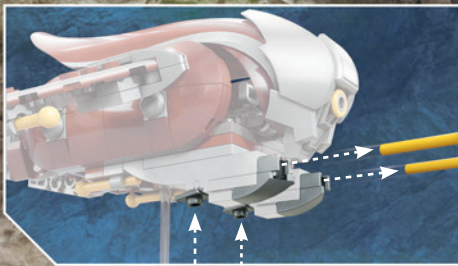

Warning: Do not aim at eyes or face. Only use projectiles supplied with this toy. Do not fire at point blank range. / Attention : Ne pas viser les yeux ou le visage. Ne pas utiliser d'autres projectiles que ceux fournis avec ce jouet. Ne pas tirer à bout portant. / Advertencia: No apuntar hacia los ojos o la cara. Utilizar exclusivamente los proyectiles suministrados con este juguete. No disparar a quemarropa. / ATENÇÃO!: Não apontar em direção aos olhos ou ao rosto. Usar apenas os projéteis fornecidos com este brinquedo. Não disparar a queima-roupa. / Avvertenza: Non mirare agli occhi o al viso. Usare solo i proiettili forniti con il giocattolo. Non sparare a distanza ravvicinata. / Achtung: Nicht auf Augen oder Gesicht zielen. Nur die zu diesem Spielzeug gehörenden Projektile verwenden. Nicht auf Menschen oder Tiere oder aus nächster Nähe zielen. Ostrzeżenie: Nie celuj w oczy i twarz. Nie strzelaj pociskami innymi niż dostarczone z zabawką. Nie strzelaj z bliska. / Waarschuwing: niet op ogen of gezicht richten. Gebruik uitsluitend de bijgeleverde projectielen. Niet van te dichtbij afschieten. / Предупреждение: Не направляйте в глаза или лицо. Используйте только снаряды, входящие в комплект. Не стреляйте со слишком близкого расстояния. / Advarsel: Sigt ikke mod øjne eller ansigt. Brug kun de projektiler, som følger med legetøjet. Skyd ikke direkte på personer eller ting. / Varning: Sikta inte mot ögon eller ansikte. Använd endast projektiler som medföljer leksaken. Fyra inte av på mycket nära håll. / Advarsel: Du må ikke sikte mot øyne eller ansikt. Bruk bare prosjektilene som følger med leken. Ikke skyt på noe på kloss hold. / Varoitus: Älä tähtää silmiin eikä kasvoihin. Käytä ainoastaan tämän tuotteen mukana tulleita ammuksia. Älä ammu lähietäisyydeltä. / Προσοχή: Μην στοχεύετε στα μάτια ή στο πρόσωπο. Χρησιμοποιείτε μόνο τα βλήματα που περιλαμβάνονται. Μην στοχεύετε όταν δεν έχετε ορατότητα. / Uyarı: Göze veya yüze nişan almayın. Fırlatmak için yalnızca bu oyuncakla birlikte verilen objeleri kullanın. İnsanlara ve hayvanlara nişan almayın. / Upozornění: Nemířte na oči nebo na obličej. Používejte pouze projektily dodávané s touto hračkou. Nestřelujte z bezprostřední blízkosti. / Figyelmeztetés: Tilos szemre és arcra célozni. Kizárólag a játékhoz mellékelt lövedékeket használja. A játékkal tilos közvetlen közelről löni. 警告: 目や顔を狙わないでください。このおもちゃに同梱されている発射物の使用するようにしてください。到達可能な距離内で火を燃やさないでください。 تحذير: يجب التصويب باتجاه العينين أو الوجه. يجب استخدام المقذوفات المزودة مع هذه اللعبة فقط. يجب عدم الإطلاق من مدى قريب.

警告: 请勿对着眼睛或脸部发射。仅使用本玩具自带的抛射物。请勿近距离射击。

1X 
AM77341BYE

4X 
AM75332APG

2X 
MA17062APG

2X 
AM78600APG

2X 
AM76558APG

4X 
AM79666APG

2X 
MA07223APG

4X 
MA03328AKM

4X 
MA03328APG

8X 
MA17127AKM

4X 
MA18623APG

4X 
MA19999APG

2X 
MA76060APG

4X 
MA76054APG

4X 
MA17018AKM

1X 
MA72090APG

2X 
MA73758APG

2X 
MA09393AKM

4X 
MA09393APG

4X 
AM79070AKM

3X 
MA74427APG

1X 
MA74427APG

3X 
MA74426APG

1X 
MA74426AWC

2X 
MA18665AKM

1X 
MA18665APG

1X 
MA18666APG

2X 
MA18666AKM

2X 
MA09013AWC

2X 
MA15484APG

2X 
MA15484AKM

1X 
AM73009AJM

2X 
MA03773APG

1X 
MA03773AKM

5X 
MA1146AKM

2X 
MA18223AWC

8X 
MA76525AKM

8X 
MA74106AKM

1X 
AS-GNB24-01

1X 
MA18329AWC

1X 
AM19199APG

1X 
AM17509AKM

2X 
MA03772APG

2X 
AM78472AKM

1X 
MA72233APG

6X 
AM78601BYE

1X 
AM18229AKM

1X 
AM18228AKM

2X 
AM76451APG

2X 
AM76452APG

2X 
MA09593APG

2X 
MA09838AWC

2X 
MA07230APG

2X 
MA74065APG

2X 
MA74064APG

2X 
AM78599APG

4X 
MA03323AKM

4X 
MA03324AKM

2X 
AM79019AWC

2X 
M09493W

2X 
MA09493AKM

2X 
MA17503AWC

2X 
AM76367AKM

2X 
MA07475APG

2X 
MA76357AJM

1X 
AM80817APG

1X 
AM80855MCX

1X 
AS-GNB24-05

1X
AS-GNB24-03



2X
MA08483AWC



1X
AM18259W



1X
AM19773AKM



1X
AS-GNB24-02

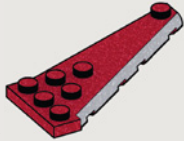

2X
MA73222AJM

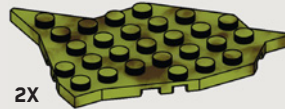

1X
MA17845AWC



1X
AM80852ATV



1X
FIG-GNB24-A



1X
FIG-GNB24-B

*Instructions included for main model only. Other build(s) can be found at megaconstrux.com / Instructions includes pour le modèle principal uniquement. Les instructions pour l'(les) autre(s) modèle(s) de construction se trouvent sur le site megaconstrux.com / Se incluyen las instrucciones para el modelo principal solamente. Se pueden encontrar otras construcciones en megaconstrux.com / Instruções incluídas somente para o modelo principal. Outras montagens podem ser encontradas em megaconstrux.com / Istruzioni incluse solo per il modello principale. È possibile trovare le altre costruzioni su megaconstrux.com / Nur für das Hauptmodell ist eine Anleitung enthalten. Unter megaconstrux.com finden Sie weitere Bauanleitungen. / Załączono instrukcje tylko do głównego modelu. Inne wersje są dostępne na megaconstrux.com / Instructies alleen bij het hoofdmodel. Andere bouw mogelijkheden kunt u vinden op megaconstrux.com / Инструкция относится только к основной модели. Другие конструкции можно найти на сайте megaconstrux.com / Οι οδηγίες που περιλαμβάνονται είναι μόνο για το κύριο μοντέλο. Μπορείτε να βρείτε άλλες κατασκευές στο megaconstrux.com / Yönergeler sadece ana modeller için dahil edilmştir. Diğer yapı parçaları megaconstrux.com adresinde bulunabilir/ Instruksjoner medfølger endast för huvudmodellen. Andra byggen finns på megaconstrux.com / Ohjeet ovat sisällytettävä vain päämallleihin. Muut kokoonpanot ovat löydettävissä osoitteessa megaconstrux.com / Vejledningen følger kun med hovedmodellen. Andre byggemodeller kan findes på megaconstrux.com / Instruksjoner kun inkludert for hovedmodellen. Annen/andre versjon/-er finner du på megaconstrux.com / Přibalené pokyny jsou pouze pro hlavní model. Ostatní stavby lze najít na megaconstrux.com / Pribalené pokyny sú iba hlavný model. Ostatné stavby možno nájsť na megaconstrux.com / A mellékelt utasítások csak a fő modellre vonatkoznak. Egyéb építőelem(ek) a megaconstrux.com weboldalon található(k) / megaconstrux.com

التعليمات موجودة للنموذج الرئيسي فقط. يمكن العثور على بناء (أبنية) أخرى على موقع

Mattel Europa B.V., Gondel 1, 1186 MJ Amstelveen, Nederland. Mattel U.K. Limited, The Porter Building, 1 Brunel Way, Slough SL1 1FQ, UK. Mattel France, Parc de la Cerisaie, 1/3/5 allée des Fleurs, 94260 Fresnes Cedex. N° Cristal 0969 36 99 99 (Numéro non surtaxé) ou www.lesjouetsmattel.fr Mattel Belgium, Trade Mart, Atomiumsquare, Bogota 202 - B 275, 1020 Brussels. Gratis nummer België: 0800 - 16 936 - Gratis nummer Luxemburg: 800 - 22 784 - Gratis nummer Nederland: 0800 - 262 88 35. Deutschland: Mattel GmbH, Solmsstraße 4, D-60486 Frankfurt am Main. Schweiz: Mattel AG, Kirchstrasse 24, CH-3097 Liebefeld. Österreich: Mattel Ges.m.b.H., Campus 21, Liebermannstraße A01 404, A- 2345 Brunn/Gebirge. Mattel Italy Srl, Via Bracco, 6-MAC 6, 20159 Milano, Italy. Servizio assistenza clienti: Customersrv.italia@mattel.com - Numero verde 800 11 37 11. Mattel España, S.A., Aribau 200, 08036 Barcelona. cservice.spain@mattel.com Tel: 902203010 <http://www.service.mattel.com/es>. Mattel East Asia Ltd., Room 503-09, North Tower, World Finance Centre, Harbour City, Tsimshatsui, HK, China. Tel.: (852) 3185-6500. Dimport & Diedarkan Oleh: Mattel Continental Asia Sdn Bhd. Level 19, Tower 3, Avenue 7, No. 8 Jalan Kerinchi, Bangsar South, 59200 Kuala Lumpur, Malaysia. Mattel South Africa (PTY) LTD, Office 102 I3, 30 Melrose Boulevard, Johannesburg 2196. Dystrybutor: Mattel Poland Sp. z o.o., Warsaw Trade Tower 34 p., ul. Chłodna 51, 00-867 Warszawa. Mattel Australia Pty. Ltd., 658 Church St, Richmond, Victoria, 3121. Consumer Advisory Service - 1300 135 312. Mattel AEBE, Εθνάρχου Μακαρίου 1, Κτήριο Κ-2, ΤΚ 17561, Πόληιο Φάληρο. Mattel Ouyuncakçılık Tic. Ltd. Şti. İcerenköy Mah., Erkut Sok. A Blok No:12 Üner Plaza Kat:9-10 34752 Ataşehir İstanbul. Tel: 0216 570 75 00. Импортёр/Полномоченная организация: ООО "МАТТЕЛ" Российская Федерация, 105120 Москва, 2-й Сыромятнинский переулок 1; +7 495 287 79 39. Forg.: Mattel Toys Hungary Kft 1139 Budapest Váci út 91. +36 1 270 0223. Mattel Czech Republic s.r.o., The Forum, Václavské nám. 19, 11000 Praha1. Mattel, Inc. 636 Girard Avenue, East Aurora, NY 14052, U.S.A. Mattel Canada Inc., Mississauga, Ontario L5R 3W2. Consumer Services: You may call us free at / Composez sans frais le 1-800-524-8697. Importado y distribuido por Mattel de México, S.A. de C.V., Miguel de Cervantes Saavedra No. 193, Pisos 10 y 11, Col. Granada, Alcaidía Miguel Hidalgo, C.P. 11520, México, Ciudad de México. R.F.C. MME-920701-NB3. Tels.: 59-05-51-00 Ext. 5206 ó 01-800-463-59-89. Mattel Chile, S.A., Avenida Américo Vespucio 501-B, Quilicura, Santiago. Tel.: 1230-020-6213. Servicio al consumidor Venezuela: Tel.: 0-800-100-9123. Mattel Argentina, S.A., Av. Libertador 1000, Piso 11 - Oficinas 109 y 111, Vicente López - Prov. Buenos Aires. Tel.: 0800-666-3373. Mattel Colombia, S.A., Calle 123#7-07 P5, Bogotá. Tel.: 01800-710-2069. Mattel Perú, S.A., Av. Juan de Arona # 151, Centro Empresarial Juan de Arona, Torre C, Piso 7, Oficina 704, San Isidro, Lima 27, Perú. RUC: 20425853865. Reg. Importador: 02350-12-JUE-DIGESA. Tel.: 0800-54744. E-mail Latinoamérica: servicioclientes@mattel.com. Mattel do Brasil Ltda. - CNPJ: 54.558.002/0001-20 - Rua Verbo Divino, 1488 - 2º. Andar - 04719-904 - Chácara Santo Antônio - São Paulo - SP - Brasil. Serviço de Atendimento ao Consumidor: fone 0800-550780. E-mail: sac.matteldobrazil@mattel.com



© 2020 Microsoft Corporation. All Rights Reserved. Microsoft, Halo, the Halo logo, Xbox, the Xbox logo, and 343 Industries are trademarks of the Microsoft group of companies.



HALO

**MORE TO COLLECT!
ENCORE PLUS À COLLECTIONNER!
MÁS PARA COLECCIONAR!
MAIS PARA COLECCIONAR!
MEHR ZUMSAMMELN!
СОБЕРИ БОЛЬШЕ!**



GNB24



GNB40



GNB21



GNB25



GNB27



BUILD & SHARE
CONSTRUIRE ET PARTAGER
CONSTRUYE Y COMPARTE | MONTAR E
COMPARTILHAR | BAUEN UND MIT
ANDEREN TEILEN | СОЗДАВАЙ И ДЕЛИСЬ

megaconstrux.com

Each sold separately and subject to availability. / Produits vendus séparément, selon la disponibilité. / Se venden por separado y están sujetos a disponibilidad. / Vendidos em separado e sujeitos à disponibilidade. / Ognuno in vendita separatamente secondo disponibilità. / Alle Artikel separat erhältlich. Einige Artikel werden nicht in allen Ländern vertrieben. Sprzedawane oddzielnie w zależności od dostępności. / Per stuk verkrijgbaar en niet overal leverbaar. / Каждый продукт продается отдельно, в зависимости от наличия. / Sælges separat og så længe lager haves. / Alla delar säljs separat så långt lagret räcker. / Hver leke selges separat så langt lageret rekker. / Jokainen myydään erikseen, saatavuus voi vaihdella. / Το καθένα πωλείται ξεχωριστά και ανάλογα με τη διαθεσιμότητα. / Her biri ayrı ayrı ve stoklara bağlı olarak satılır. Každá hračka se prodává samostatně dle aktuální nabídky. Každé sa predáva samostatne a podľa dostupnosti. / Mindegyik külön kapható, elérhetőségük változhat. / それぞれ在庫状況によって個別に販売されます。

تباع كل منها على حدة وتخضع لتوفره.
每件单独出售，并且视库存情况而定。



MIX
Paper from responsible sources
Papier issu de sources responsables
FSC® C011825

© D714,887, D841,101

1186 MJ, 1, NL



MEGA Brands Inc. Montreal QC H4T 1K4 Canada

MADE IN CANADA WITH DOMESTIC AND IMPORTED COMPONENTS. FABRIQUÉ AU CANADA AVEC DES COMPOSANTS DOMESTIQUES ET IMPORTÉS.
FABRICADO NO CANADÁ COM COMPONENTES CANADIANOS E IMPORTADOS. FABRICADO EN CANADÁ CON PIEZAS FABRICADAS EN CANADÁ Y
PIEZAS IMPORTADAS. ИЗГОТОВЛЕНО В КАНАДЕ С ОТЕЧЕСТВЕННЫМИ И ИМПОРТНЫМИ КОМПОНЕНТАМИ. YERLİ VE İTHAL PARÇALARLA KANADA'DA ÜRETİLMİŞTİR.

©2020, MEGA Brands Inc. &™ MEGA Brands Inc. CONSTRUX™ is owned by Mattel and used under license. CONSTRUX™ appartient à Mattel et est utilisée sous licence. Printed in Canada / Imprimé au Canada D-GNB24-01

صنع في كندا من مواد محلية ومستوردة