

**Fisher-Price®**

H6372  
Instructions

## Stride-to-Ride Learning Walker™

Please keep this instruction sheet for future reference, as it contains important information.

Maximum weight:  
42 lbs. (19 kg).  
For ages between  
9 months and  
3 years.

Requires three "AA"  
batteries (included).

Adult assembly is required.

Tool required for  
battery replacement:  
Phillips screwdriver  
(not included).



**Laugh & Learn**™

[www.fisher-price.com](http://www.fisher-price.com)

## Before Use

### ⚠ CAUTION

Please keep small parts such as plastic tabs out of children's reach. Throw the plastic tab away.

**Note:** A plastic tab is attached to the toy for in-store demonstration purposes. While the tab may have already been removed, check the dashboard to be sure. If the plastic tab is still attached, pull and remove the tab from the toy. Throw the plastic tab away.

## Parts

### ⚠ CAUTION

This product contains small parts in its unassembled state. Adult assembly is required.

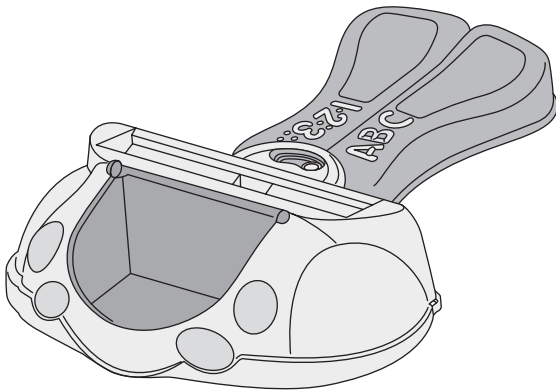

**Base**

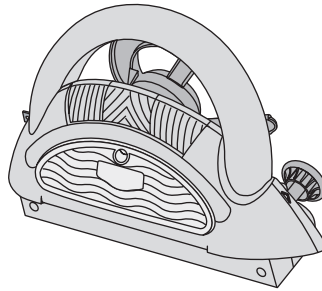

**Dashboard**

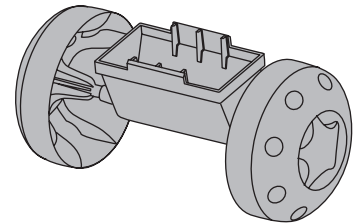

**Front Wheels**

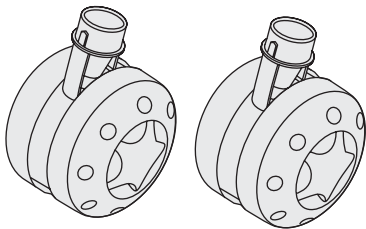

**2 Caster Wheels**

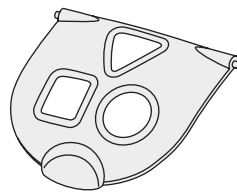

**Hood**

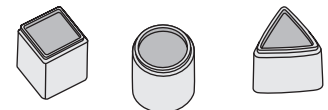

**3 Shape Sorter Blocks**

# Assembly

1

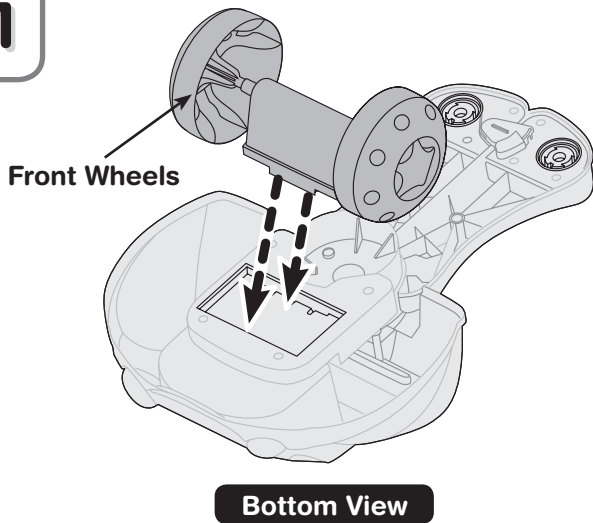

- Place the base upside down on a flat surface.
- **“Snap”** the front wheels to the underside of the base, as shown.

3

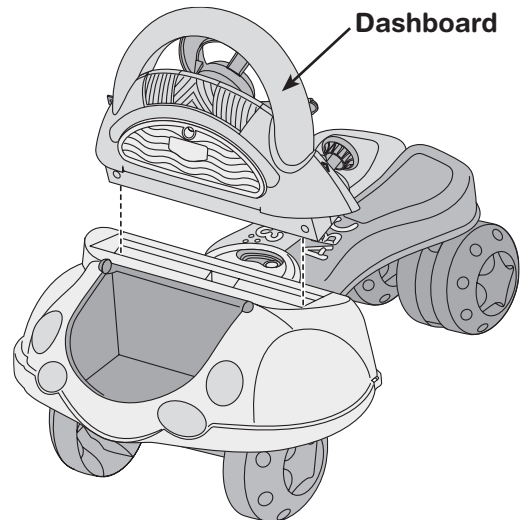

- Insert and **“snap”** the dashboard into the base, as shown.
- Hint: This may require some force.*
- Pull up on the dashboard to be sure it is secure to the base.

2

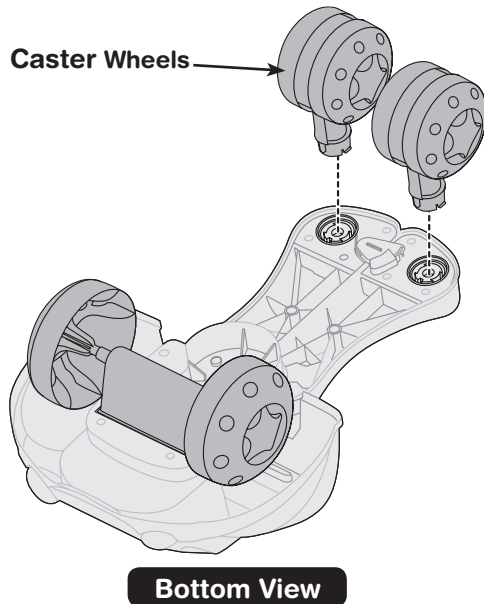

- Insert and **“snap”** the caster wheels into the base, as shown.
- Hint: This may require some force.*
- Pull up on the caster wheels to be sure they are secure to the base. Turn the base over.

4

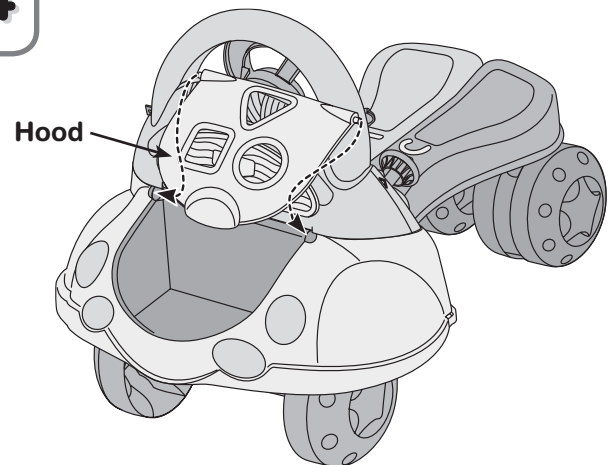

- Fit the peg on the left side of the hood into the matching hole in the dashboard.
  - Press to **“snap”** the other peg into the dashboard.
- One time assembly is now complete.**

## Battery Replacement

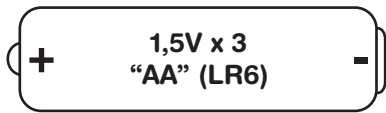

SHOWN ACTUAL SIZE

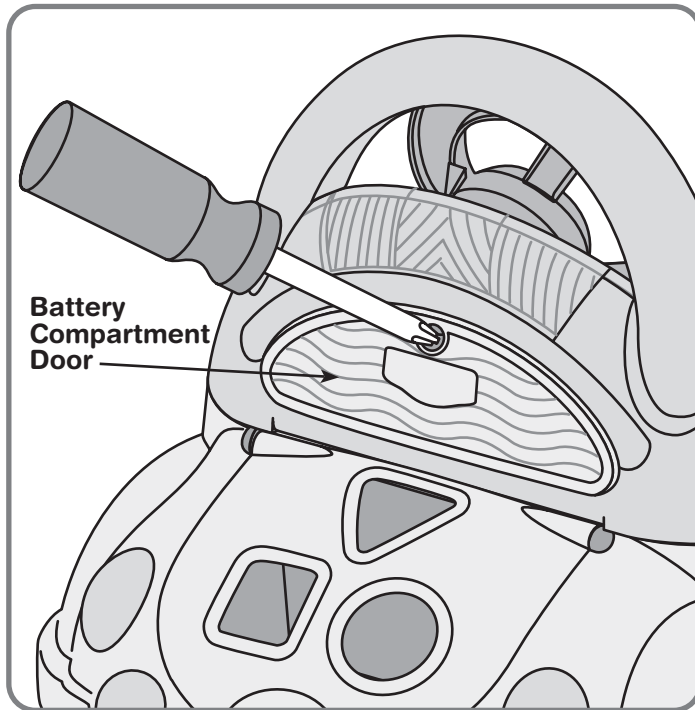

**For best performance, we recommend replacing the batteries that came with this toy with three, new alkaline "AA" (LR6) batteries.**

- Locate the battery compartment on the dashboard.
- Loosen the screws in the battery compartment door with a Phillips screwdriver. Remove the battery compartment door.
- Insert three "AA" (LR6) **alkaline** batteries, as indicated inside the battery compartment.

**Hint:** We recommend using **alkaline** batteries for longer life.

- Replace the battery compartment door and tighten the screws with a Phillips screwdriver. Do not over-tighten.
- When lights or sounds from this toy become faint or stop, it's time for an adult to change the batteries!

## Battery Safety Information

In exceptional circumstances, batteries may leak fluids that can cause a chemical burn injury or ruin your product. To avoid battery leakage:

- Do not mix old and new batteries or batteries of different types: alkaline, standard (carbon-zinc) or rechargeable (nickel-cadmium).
- Insert batteries as indicated inside the battery compartment.
- Remove batteries during long periods of non-use. Always remove exhausted batteries from the product. Dispose of batteries safely. Do not dispose of batteries in a fire. The batteries may explode or leak.
- Never short-circuit the battery terminals.
- Use only batteries of the same or equivalent type as recommended.
- Do not charge non-rechargeable batteries.
- Remove rechargeable batteries from the product before charging.
- If removable, rechargeable batteries are used, they are only to be charged under adult supervision.

## FCC Note (United States Only)

**Note:** This equipment has been tested and found to comply with the limits for a Class B digital device, pursuant to Part 15 of the FCC Rules. These limits are designed to provide reasonable protection against harmful interference in a residential installation. This equipment generates, uses and can radiate radio frequency energy and, if not installed and used in accordance with the instructions, may cause harmful interference to radio communications. However, there is no guarantee that interference will not occur in a particular installation. If this equipment does cause harmful interference to radio or television reception, which can be determined by turning the equipment off and on, the user is encouraged to try to correct the interference by one or more of the following measures:

- Reorient or relocate the receiving antenna.
- Increase the separation between the equipment and receiver.
- Consult the dealer or an experienced radio/TV technician for help.

Note: Changes or modifications not expressly approved by the manufacturer responsible for compliance could void the user's authority to operate the equipment.

# Walker

To change to Walker mode, follow these steps:

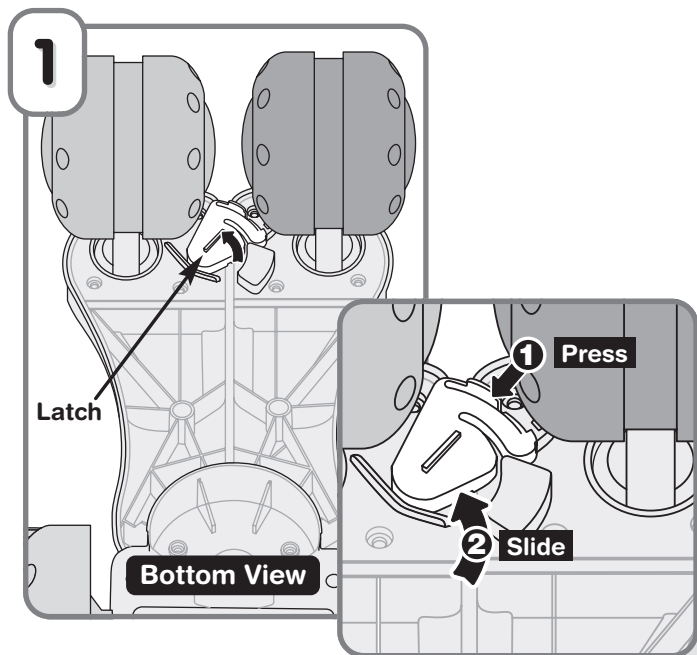

- Turn the toy over. Press and slide the latch to an open position, as shown.

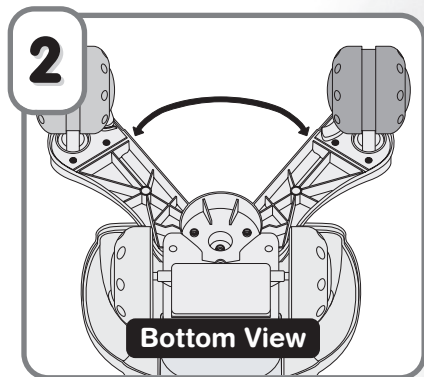

- Spread the seat halves until they “click” in place. Turn the toy over. It is now ready to be used as a walker.



## Ride-On

To change to Ride-On mode, follow these steps:

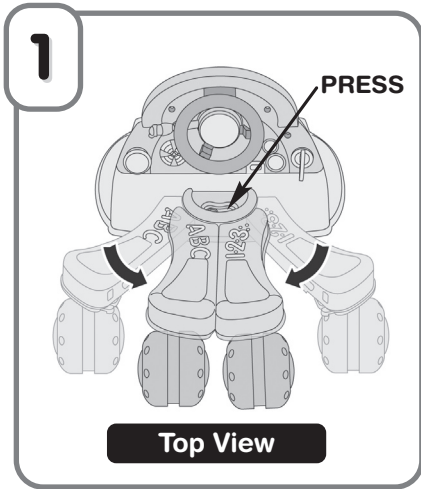

- Press the button and hold it while closing the seat halves. Turn the toy over.

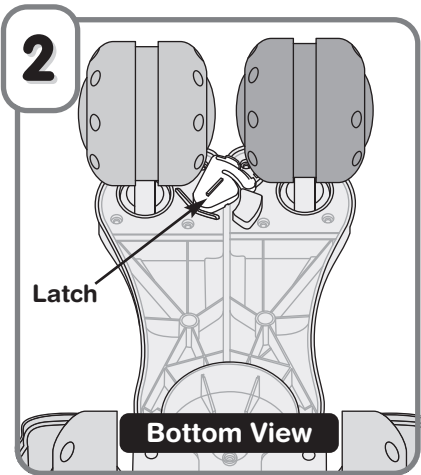

- Slide the latch to a closed position. It should “click” into place. Turn the toy over. It is now ready to be used as a ride-on.



## Two Fun Ways to play!

- Locate the mode switch on the dashboard. Slide the switch to either learning mode **ABC**; music mode **🎵** or off **○**.
- When your child is finished playing with this toy, slide the mode switch to the off **○** position.
- Locate the volume switch on the dashboard. Adjust volume to high **🔊** or low **🔇**, for your child's comfort.
- Low battery power may affect toy function, including irregular sound/lights and the toy may not turn off.
- Replace all batteries with **alkaline** batteries only.

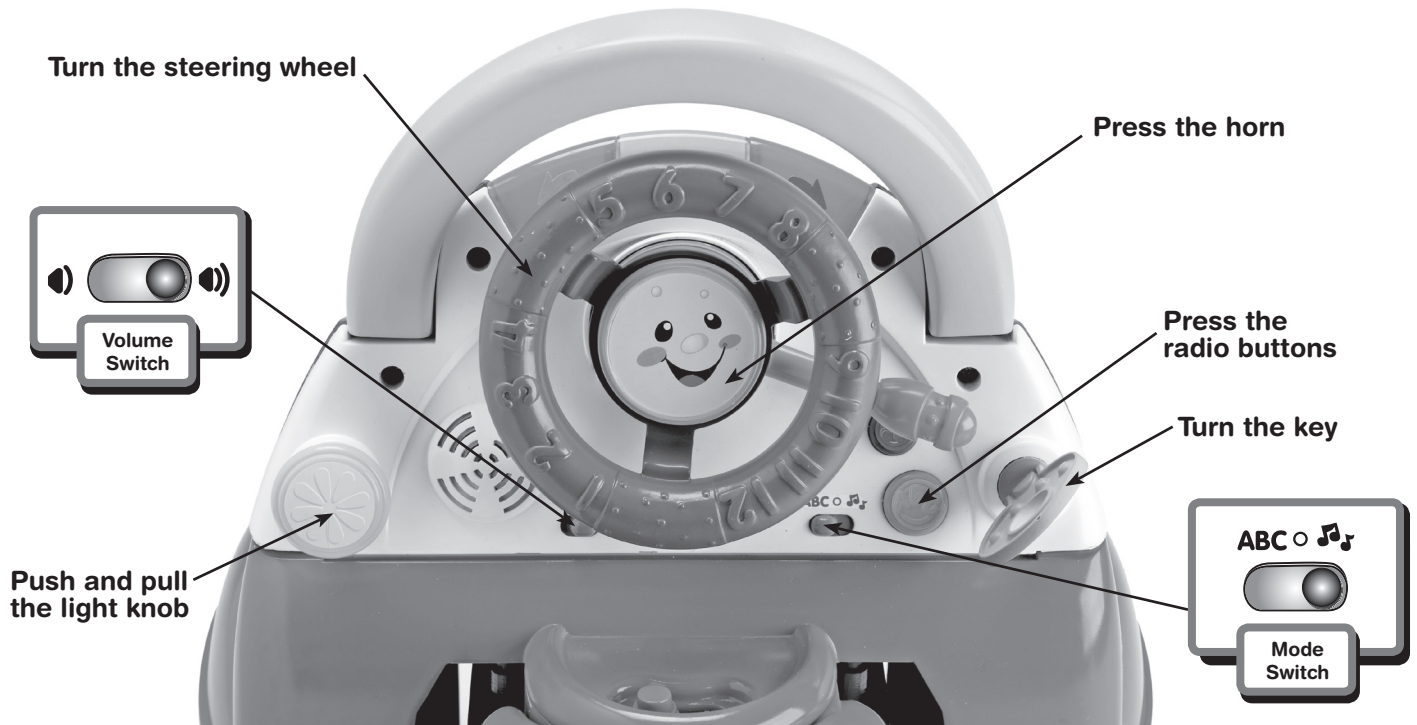

### ABC Learning Mode

- Turn the steering wheel to learn “left” and “right” or hear a short song.
- Press the horn to hear it identified. Press again to hear a short tune.
- Push or pull the light knob to learn about “off” and “on” or “push” and “pull”.
- Press the radio buttons to hear a “deejay” and one of several fun songs.
- Turn the key to learn about “on” and “off”.
- Open or close the hood to learn about “open” and “closed” or “up” and “down”.

### 🎵 Music Mode

- Turn the steering wheel to hear a fun song.
- Press the horn and hear a fun tune.
- Push or pull the light knob for a fun sound effect or short tune.
- Press the radio buttons to hear a “deejay” and one of several fun songs.
- Turn the key to hear another cheery tune.
- Open or close the hood to hear more fun tunes.

## Care

Wipe this toy with a clean cloth dampened with a mild soap and water solution. Do not immerse this toy.  
This toy has no consumer serviceable parts.  
Do not take this toy apart. Do not drop this toy on a hard surface.

## Consumer Information

Visit us on line at [www.service.fisher-price.com](http://www.service.fisher-price.com).

Call Fisher-Price® Consumer Relations, toll-free at **1-800-432-5437**, 8 AM - 6 PM EST Monday through Friday.  
Hearing-impaired consumers using TTY/TDD equipment, please call 1-800-382-7470.

Write to us at: Fisher-Price® Consumer Relations, 636 Girard Avenue, East Aurora, New York 14052.

## Learn every day - through fun, familiar play!

Make learning more fun with the whole collection of **Laugh & Learn™** toys. With rich music, lyrics and lots of activities, they combine early academics and everyday experiences, for the way kids really learn.

Each sold separately and subject to availability.



**Learning Pots & Pans™**  
G6685



**Learning Home™**  
C6327



**Learning Phone™**  
C6324

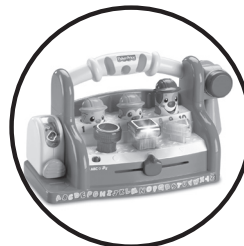

**Learning Toolbench™**  
G6167



**Musical Learning Chair™**  
H4609



**Learning Puppy™**  
C6325



**Learning Table™**  
C5522



**Learning Keys**  
G9452



**Learning Birdbath™**  
C6513

For countries outside the United States:

**CANADA:** Questions? 1-800-432-5437. Mattel Canada Inc., 6155 Freemont Blvd., Mississauga, Ontario L5R 3W2; [www.service.mattel.com](http://www.service.mattel.com).

**GREAT BRITAIN:** Mattel UK Ltd, Vanwall Business Park, Maidenhead SL6 4UB. Helpline: 01628 500303. [www.service.mattel.com/uk](http://www.service.mattel.com/uk)

**AUSTRALIA:** Mattel Australia Pty. Ltd., 658 Church Street, Locked Bag #870, Richmond, Victoria 3121 Australia. Consumer Advisory Service 1300 135 312.

**NEW ZEALAND:** 16-18 William Pickering Drive, Albany 1331, Auckland.

**ASIA:** Mattel East Asia Ltd, Room 1106, South Tower, World Finance Centre, Harbour City, Tsimshatsui, HK, China.