

Let's Play!

Set the stop-track to "STOP". (Interactive engines also can be activated on the stop-track.)

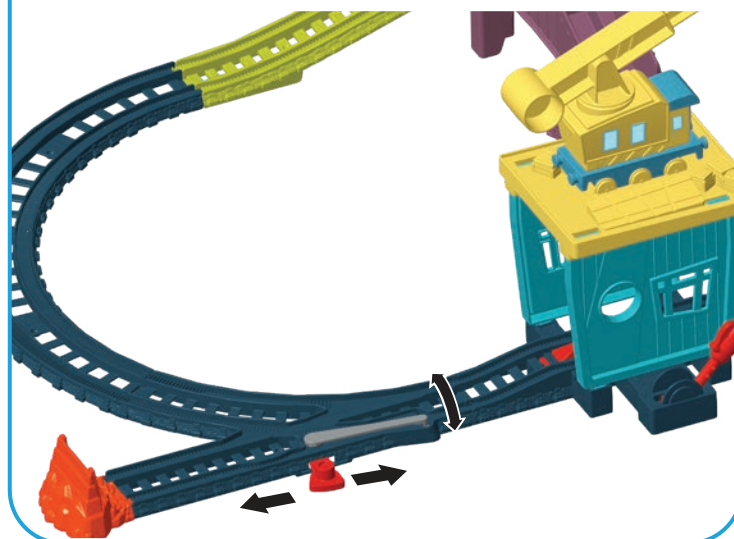

Use the switch track to change tracks.



Flip the switch on back of Thomas to turn power on.



As Thomas stops, manually hook Sandy, then spin Carly to load her into the cargo car.

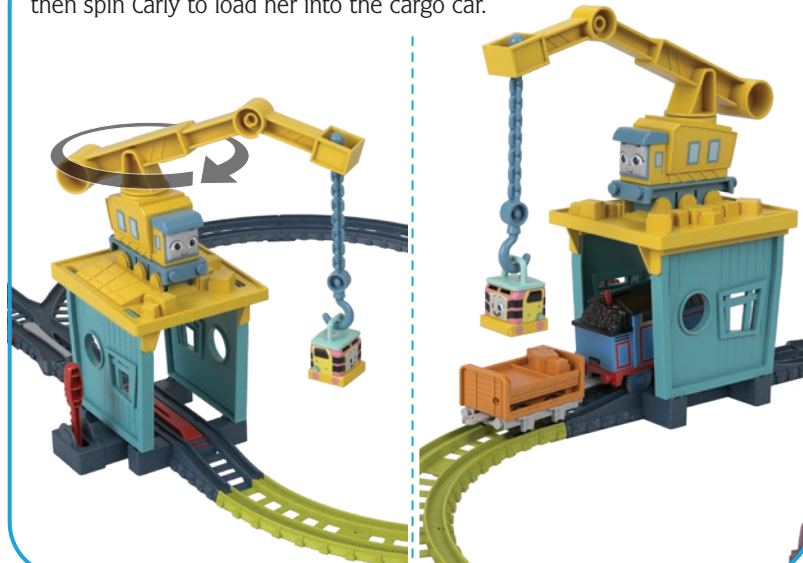

Power Switch

As the cargo car passes, Sandy falls down the ramp to the platform.

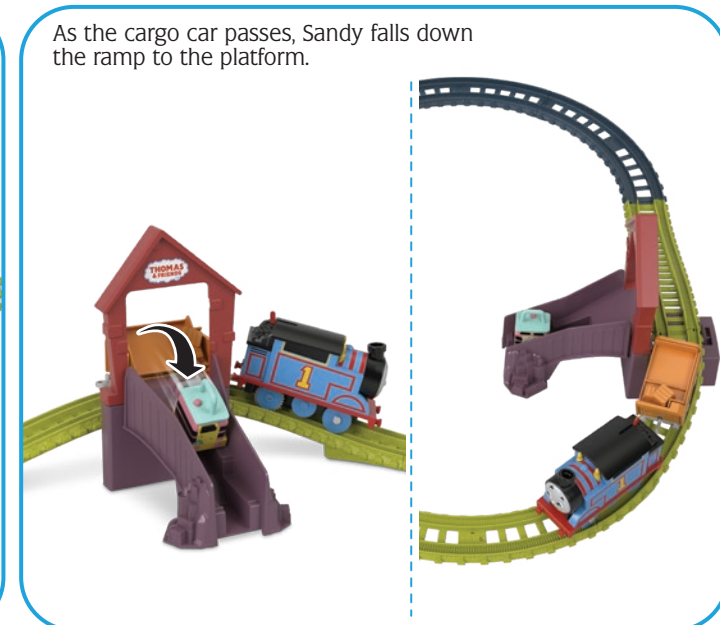
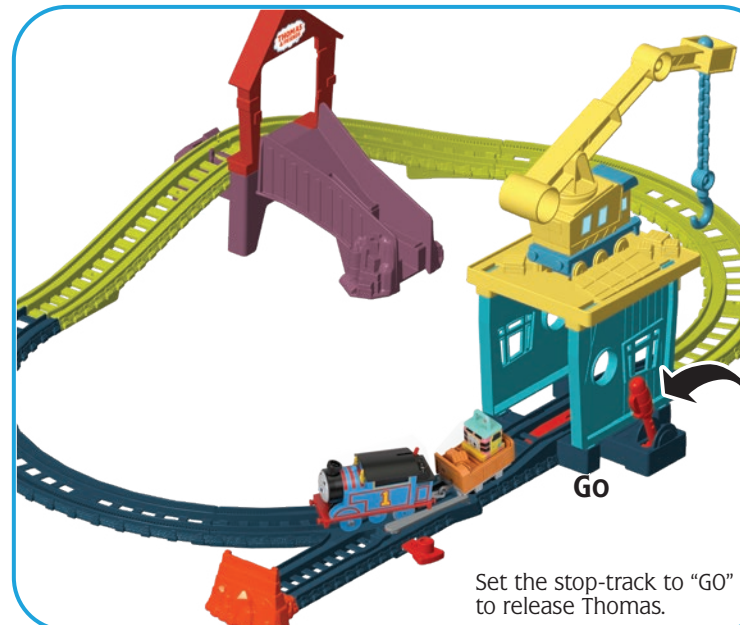

Set the stop-track to "GO" to release Thomas.

Helpful Hints



Look for codes on the bottom of each track.

Some engines may not work on this track set.



Assembly steps marked with a star indicate a permanent assembly. Once these parts are assembled, they can't be taken apart.

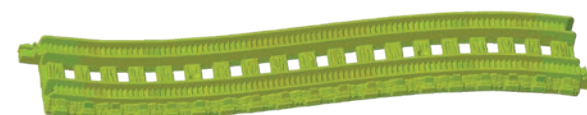

This set includes tracks with a bend so that the engine can climb up and travel down!

Consumer Information



service.mattel.com

UNITED STATES

Fisher-Price, Inc., 636 Girard Avenue, East Aurora, NY 14052.
Consumer Services: 1-800-432-5437.

CANADA

Mattel Canada Inc., 6155 Freemont Blvd., Mississauga, Ontario L5R 3W2.
Consumer Services/Service à la clientèle: 1-800-432-5437. www.service.mattel.com.

GREAT BRITAIN

Mattel U.K. Limited, The Porter Building, 1 Brunel Way,
Slough SL1 1FQ, UK. www.service.mattel.com/uk.

NEDERLAND

Mattel Europa B.V., Gondel 1, 1186 MJ Amstelveen, Nederland.

AUSTRALIA

Mattel Australia Pty. Ltd., 658 Church Street, Locked Bag #870, Richmond, Victoria 3121 Australia.
Consumer Advisory Service 1300 135 312.

NEW ZEALAND

16-18 William Pickering Drive, Albany 1331, Auckland.

SOUTH AFRICA

Mattel South Africa (PTY) LTD, Office 102 I3, 30 Melrose Boulevard, Johannesburg 2196.



CREATED BY BRITT ALLCROFT

Based on the Railway Series by The Reverend W Awdry.

©2021 Gullane (Thomas) Limited. Thomas the Tank Engine & Friends™ and Thomas & Friends™ are trademarks of Gullane (Thomas) Limited.

©2021 HIT Entertainment Limited. HIT and the HIT logo are trademarks of HIT Entertainment Limited.

©2021 Mattel. ® and ™ designate U.S. trademarks of Mattel, except as noted. PRINTED IN CHINA. Mattel East Asia Ltd., Room 503-09, North Tower, World Finance Centre, Harbour City, Tsimshatsui, HK, China. Tel.: (852) 3185-6500.



HDV58

fisher-price

HDV58-0970G2-1102694422-DDM

6/17/2021 remark for G1
- Enlarge the layout

6/17/2021 remark for G2
- Updated the product color

front	5	Back	6	Cover	1
back	2	3	4		

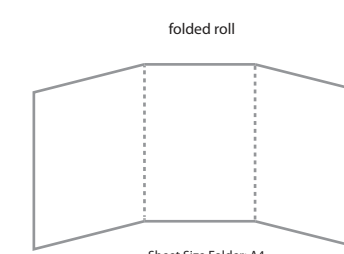

Sheet Size Folder: A4

Item No : HDV58-0970G2-1102694422-DDM
Size : 630mm X 290mm
Paper : 70gsm FSC mix woodfree paper
Color : 4C
Date : 6/17/2021 (Emma Wei)



Adult assembly required.

INSTRUCTIONS

Keep these instructions for future reference as they contain important information.

What's Included

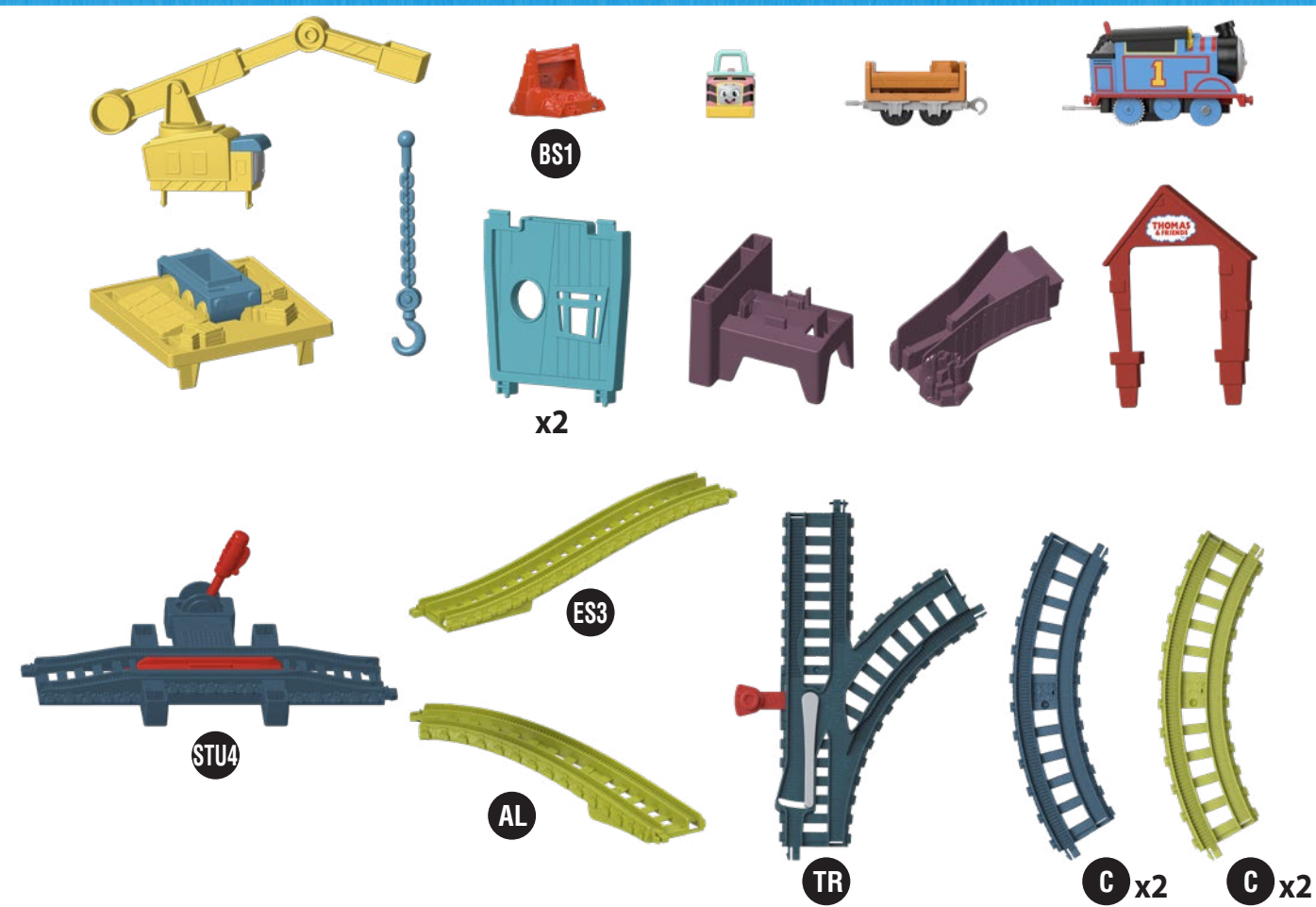

Assembly

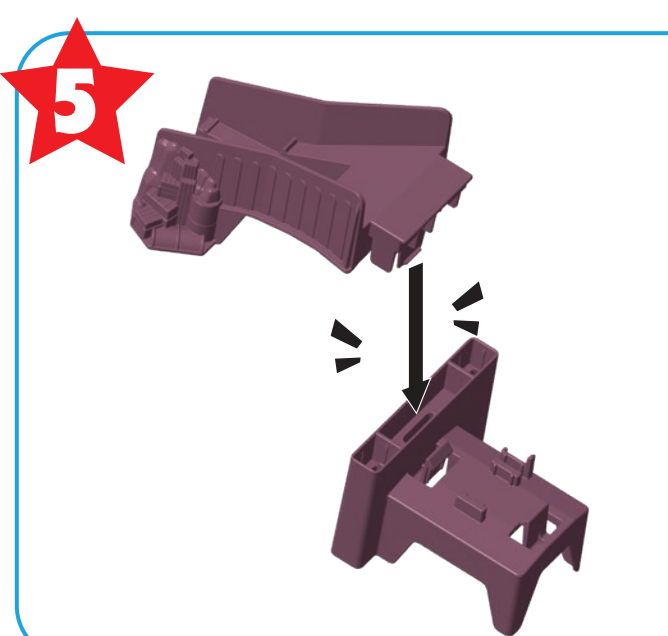
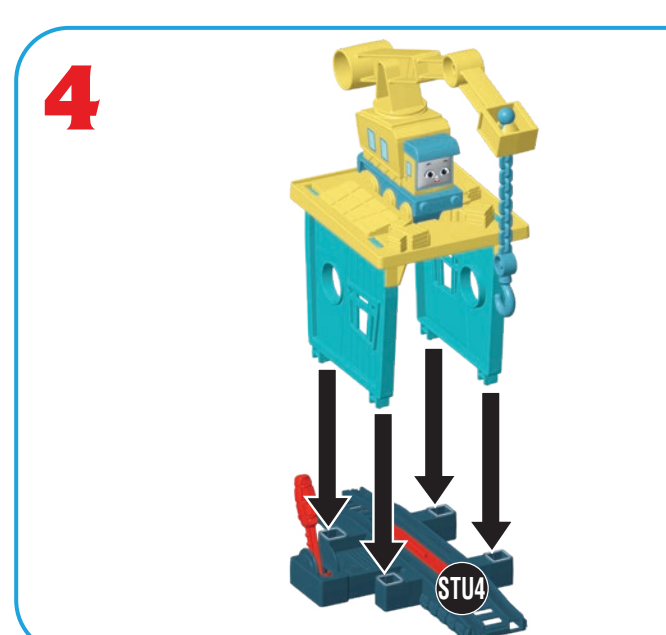
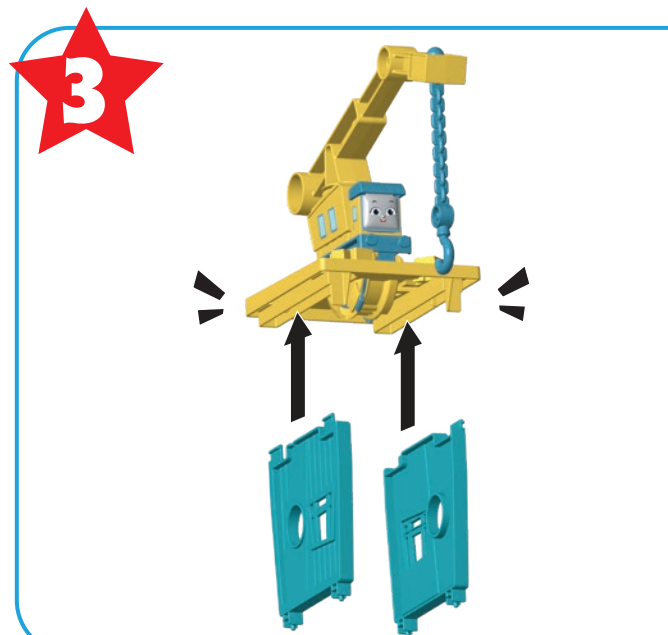
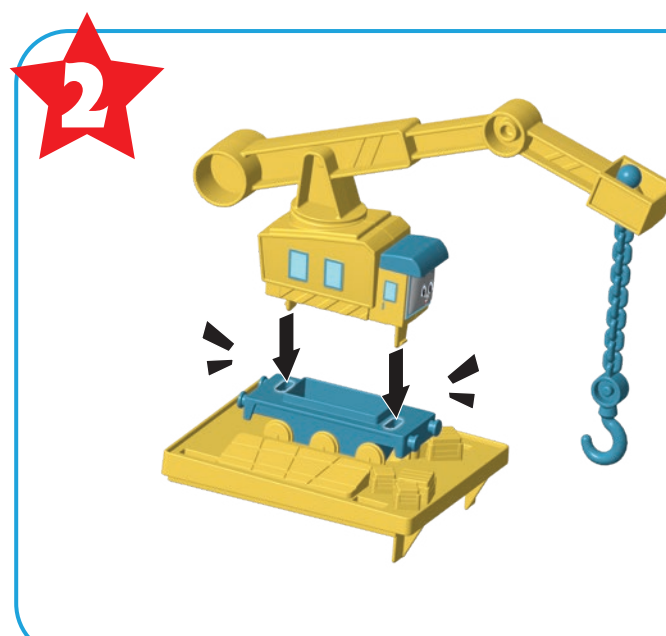
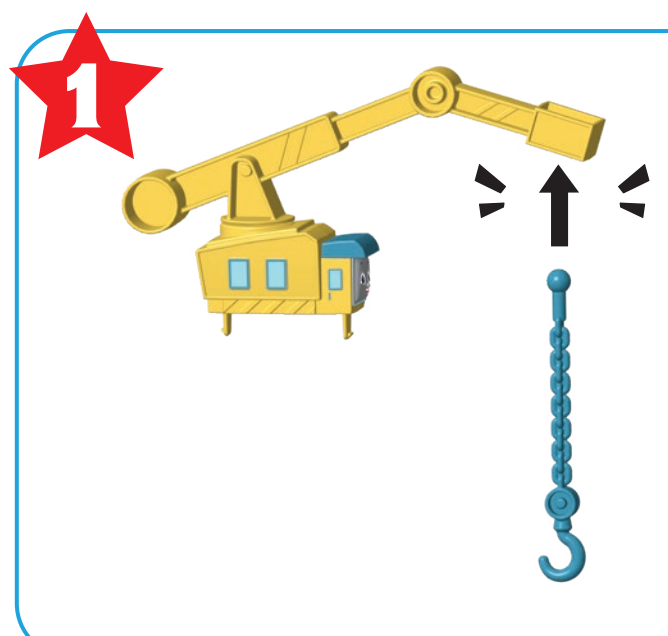

Battery Information

1.5V AAA (LR03) x2

REQUIRES:

- Phillips screwdriver (not included) for battery installation.
- Two AAA (LR03) alkaline batteries (not included).

BATTERY INSTALLATION

Access the battery compartment by loosening the screw in the bottom of the engine and separating the top half of the engine from the bottom half of the engine. Install the batteries as indicated inside the battery compartment. Re-assemble the halves of the engine and tighten the screw. If the engine begins to malfunction, first check battery installation. You may need to reset the electronics by removing the batteries and reinstalling them. If the engine continues to malfunction or no longer operates, it's time to replace the batteries with fresh batteries. For longer life, use alkaline batteries.

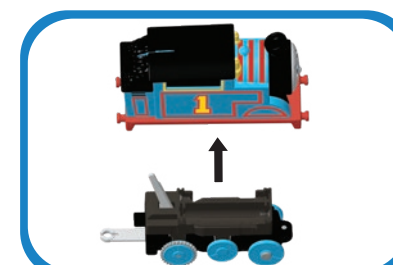
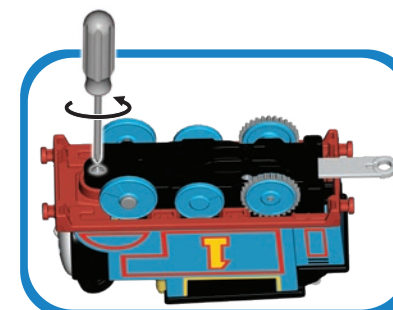

BATTERY SAFETY INFORMATION

- In exceptional circumstances batteries may leak fluids that can cause a chemical burn injury or ruin your product. To avoid battery leakage:
- Non-rechargeable batteries are not to be recharged.
 - Rechargeable batteries are to be removed from the product before being charged.
 - Rechargeable batteries are only to be charged under adult supervision.
 - Do not mix alkaline, standard (carbon-zinc), or rechargeable batteries.
 - Do not mix old and new batteries.
 - Only batteries of the same or equivalent type as recommended are to be used.
 - Batteries are to be inserted with the correct polarity (+ and -).
 - Exhausted batteries are to be removed from the product.
 - The supply terminals are not to be short-circuited.
 - Dispose of batteries safely.
 - Do not dispose of this product in a fire. The batteries inside may explode or leak.



Protect the environment by not disposing of this product or any batteries with household waste. This symbol indicates that this product shall not be treated as household waste. Check your local authority for recycling advice and facilities.

Ready to Play?

