

For best performance, here is a list of recommended cars for this track set.

16 Angels™ Low Carbs™	Ferrari 360 Modena Phastasm™	Krazy 8s® Speed Blaster®
--------------------------	---------------------------------	-----------------------------

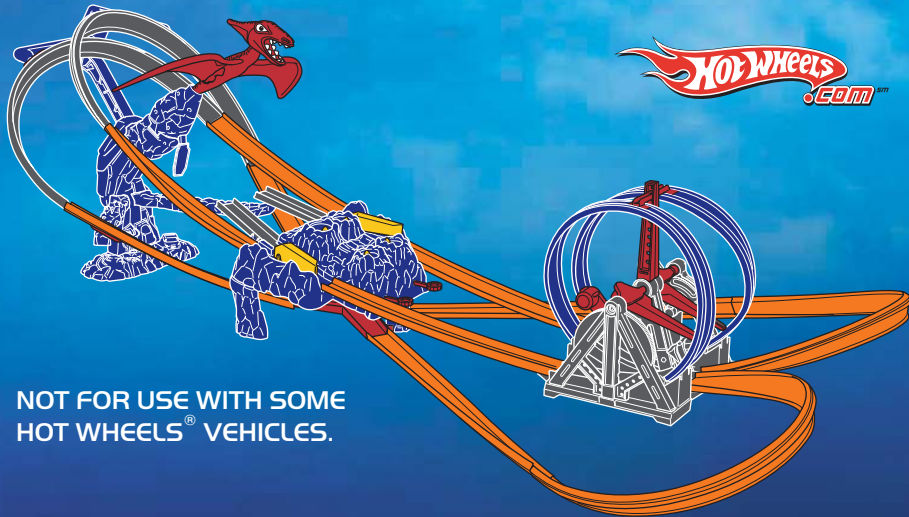

FINAL ASSEMBLY



NOT FOR USE WITH SOME HOT WHEELS® VEHICLES.

Mattel, Inc., 333 Continental Blvd., El Segundo, CA 90245 U.S.A. Consumer Relations 1 (800) 524-8697 service.mattel.com. • Mattel Canada Inc., Mississauga, Ontario L5R 3W2. You may call us free at 1-800-524-8697. • Mattel U.K. Ltd., Vanwall Business Park, Maidenhead SL6 4UB. Helpline 01628500303 • Mattel Australia Pty., Ltd., Richmond, Victoria. 3121. Consumer Advisory Service - 1300 135 312. • Mattel East Asia Ltd., Room 1106, South Tower, World Finance Centre, Harbour City, Tsimshatsui, HK. China. • Diimport & Diedarkan Oleh: Mattel SEA Ptd Ltd. (993532-P) Lot 13.5, 13th Floor, Menara Lien Hoe, Persiaran Tropicana Golf Country Resort, 47410 PJ. Tel:03-78803817, Fax:03-78803867.

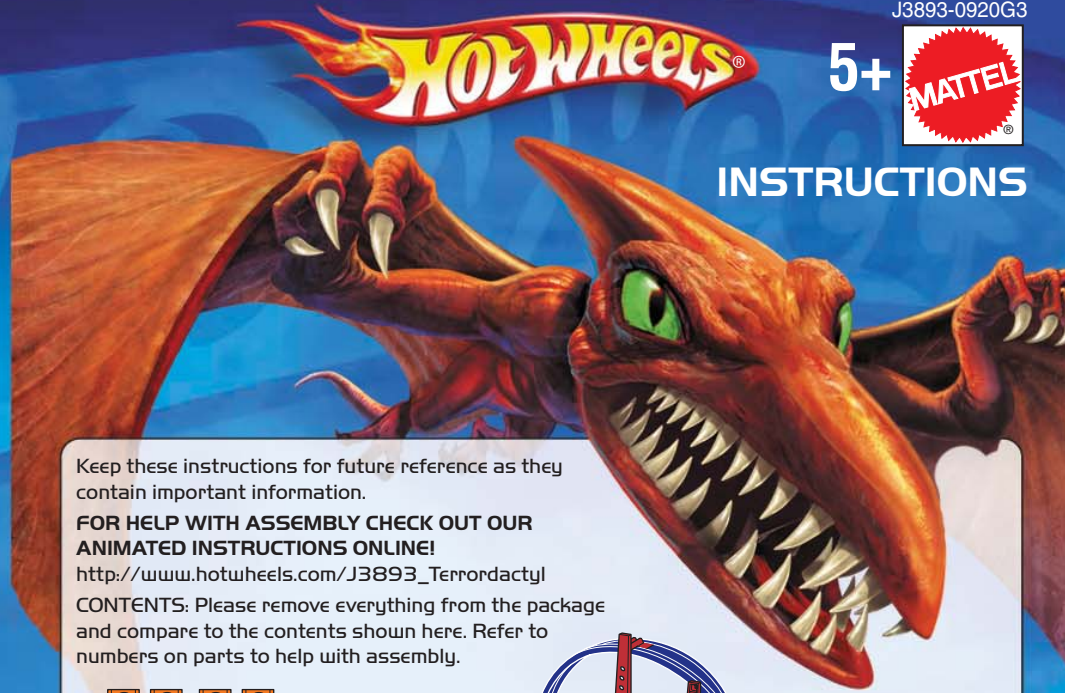

INSTRUCTIONS

Keep these instructions for future reference as they contain important information.

FOR HELP WITH ASSEMBLY CHECK OUT OUR ANIMATED INSTRUCTIONS ONLINE!

http://www.hotwheels.com/J3893_Terrordactyl

CONTENTS: Please remove everything from the package and compare to the contents shown here. Refer to numbers on parts to help with assembly.

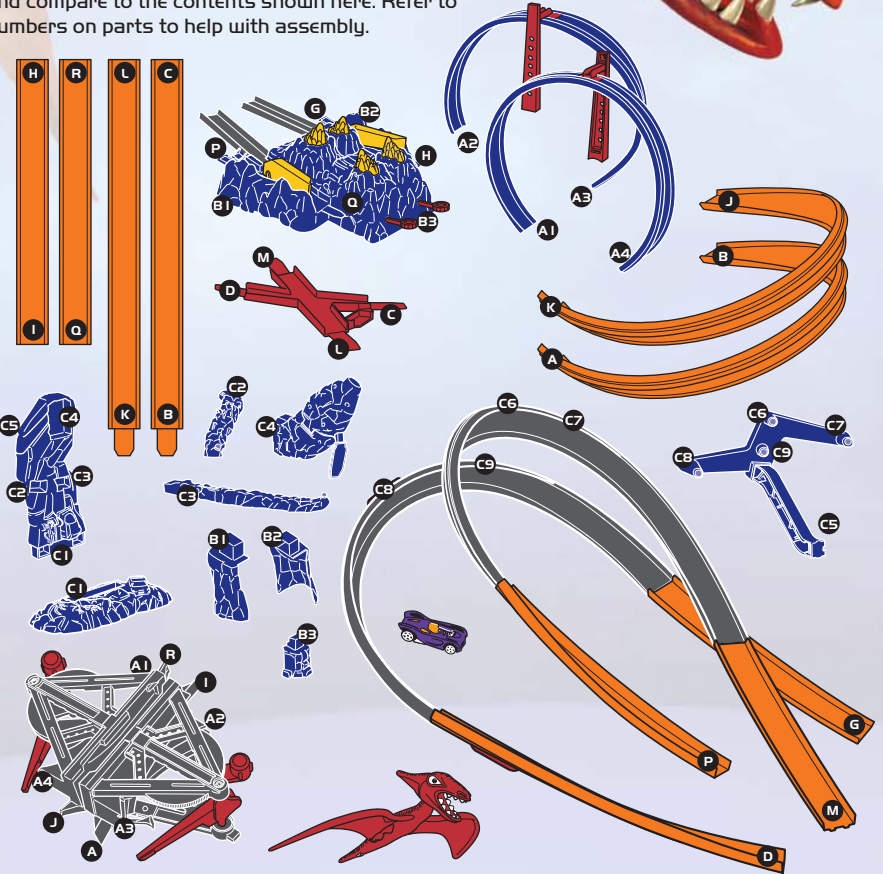

1 ASSEMBLY - A

Swing up one side of the launcher and snap the two halves together.

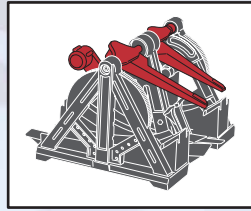
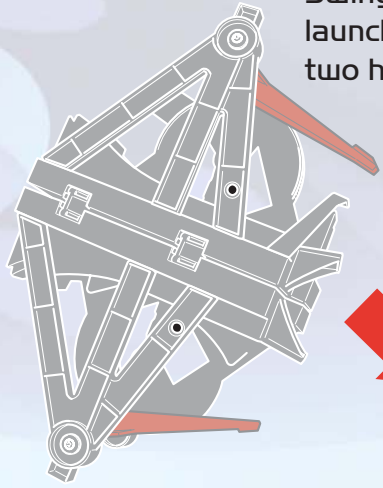

SNAP!

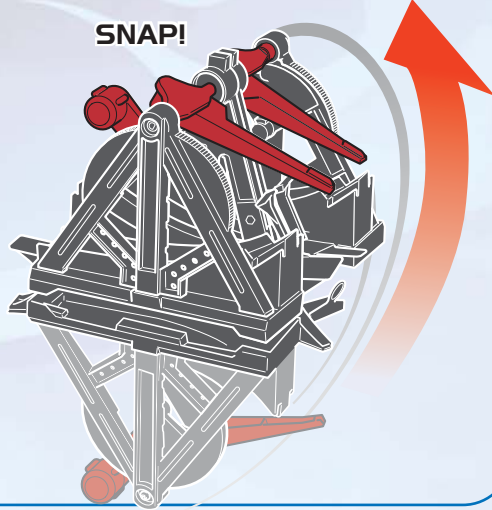

3 Attach both ends of loop track to launcher.

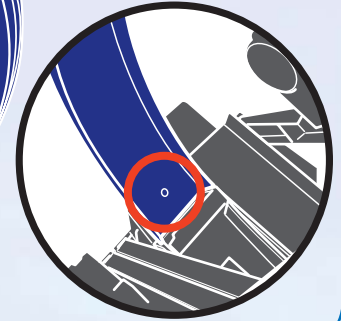
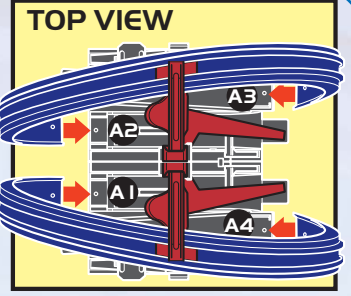
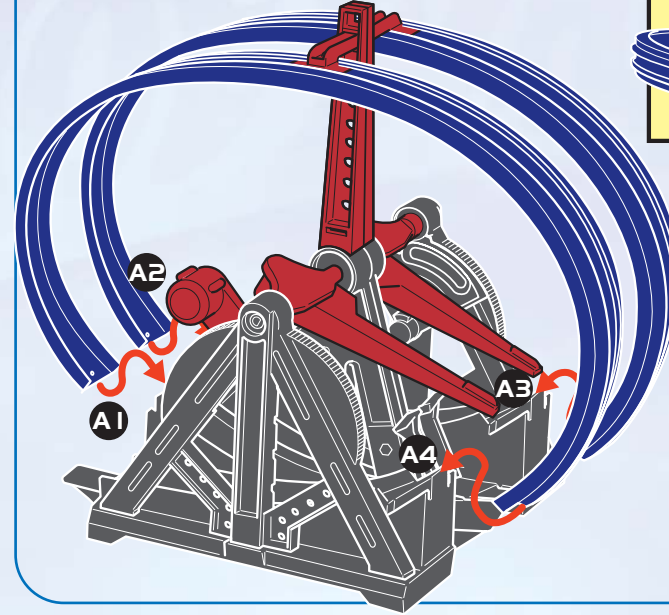

2

SNAP!
SNAP!

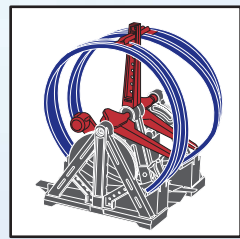
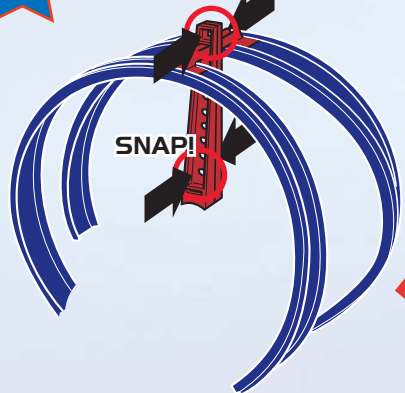

Add track loops to launcher as shown.

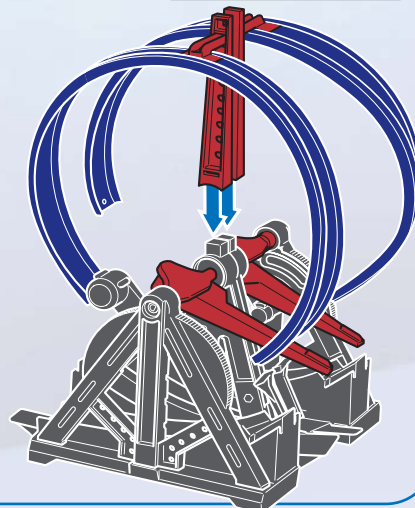

4

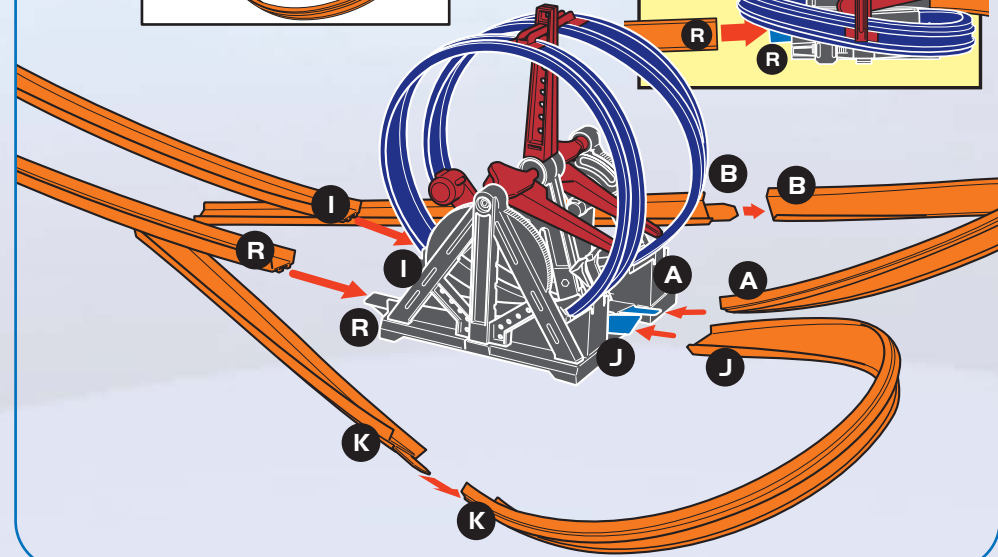
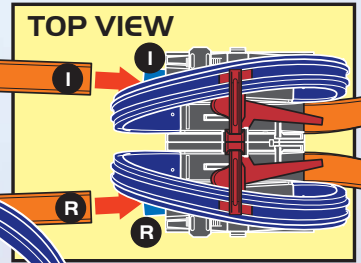
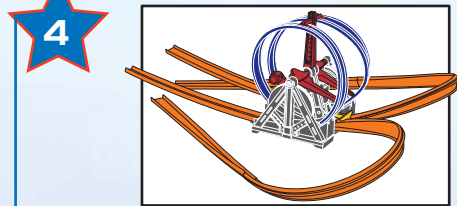

5 ASSEMBLY - B

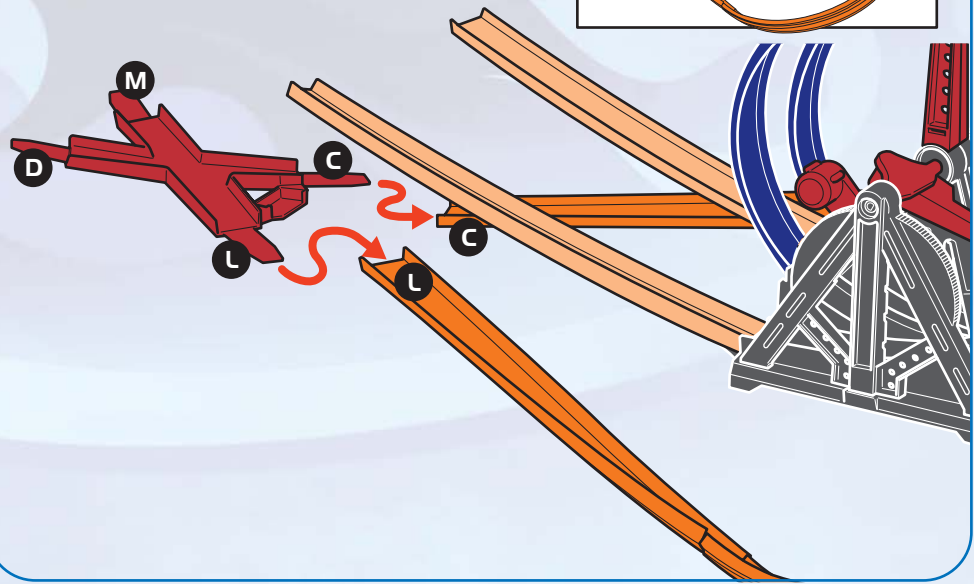
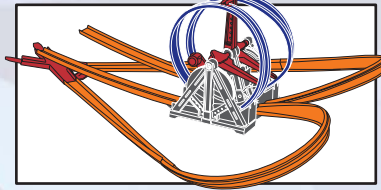

7

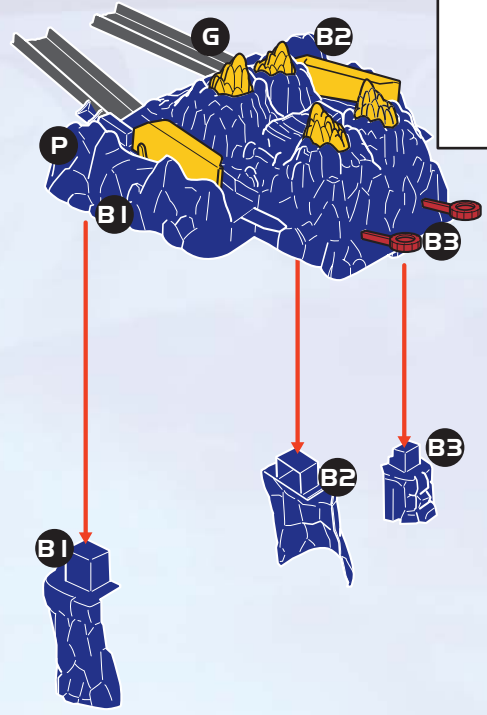
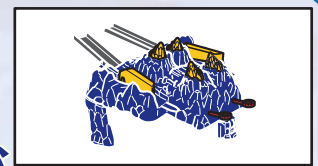

6

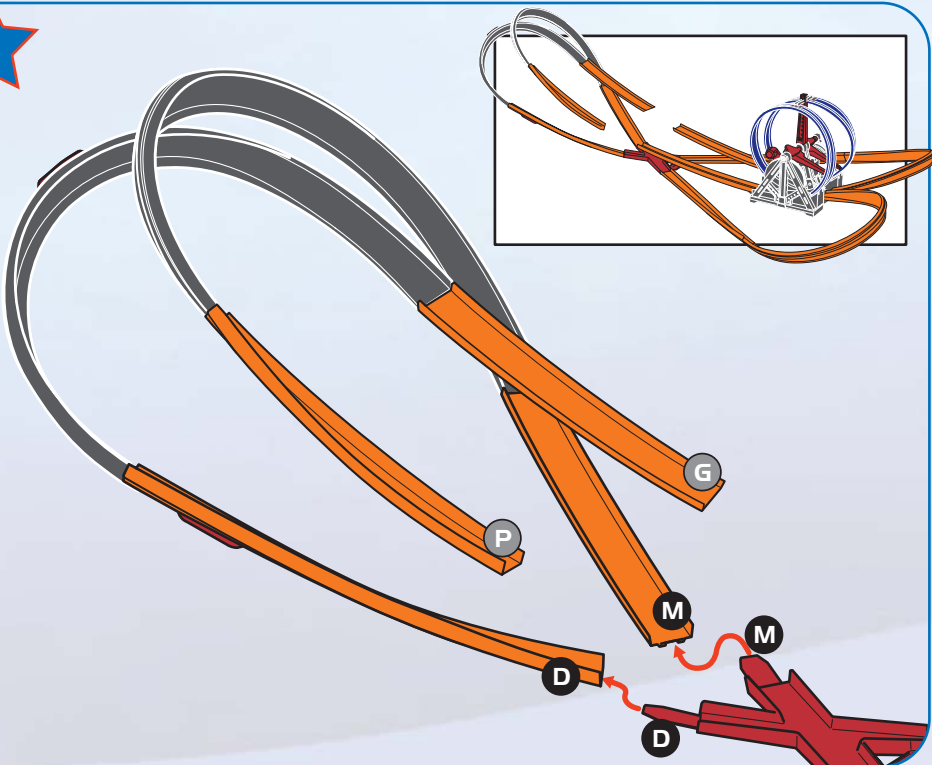
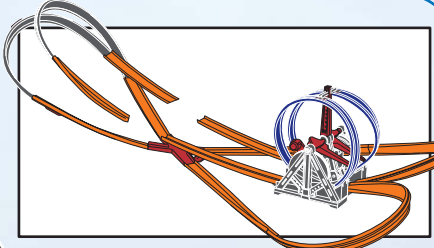

8

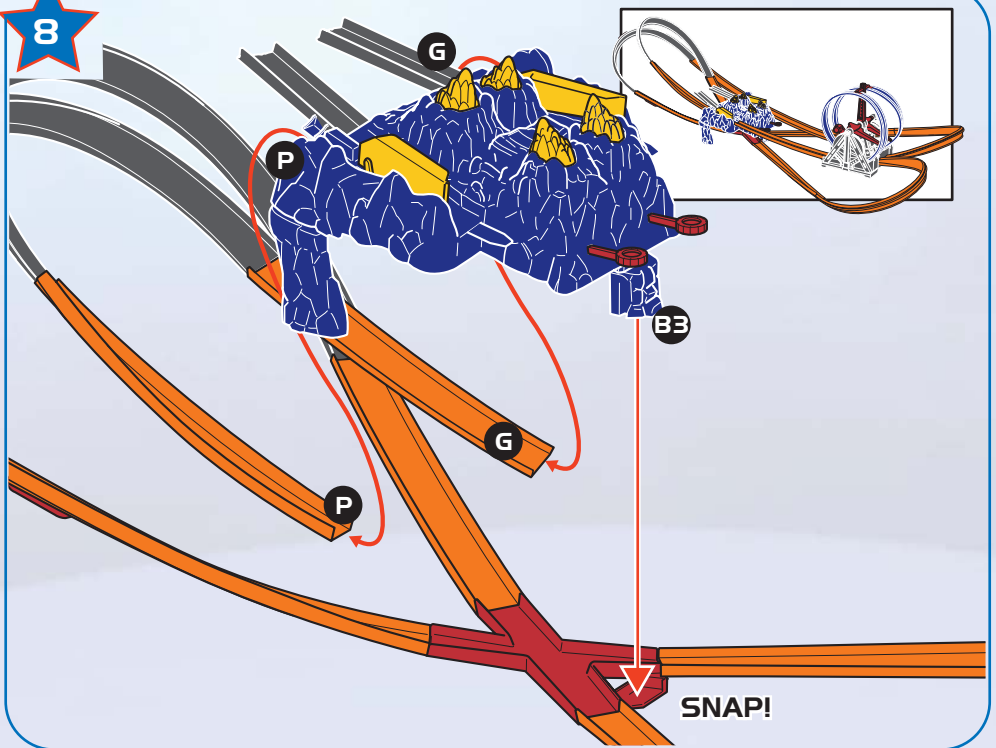
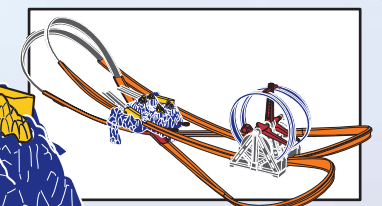

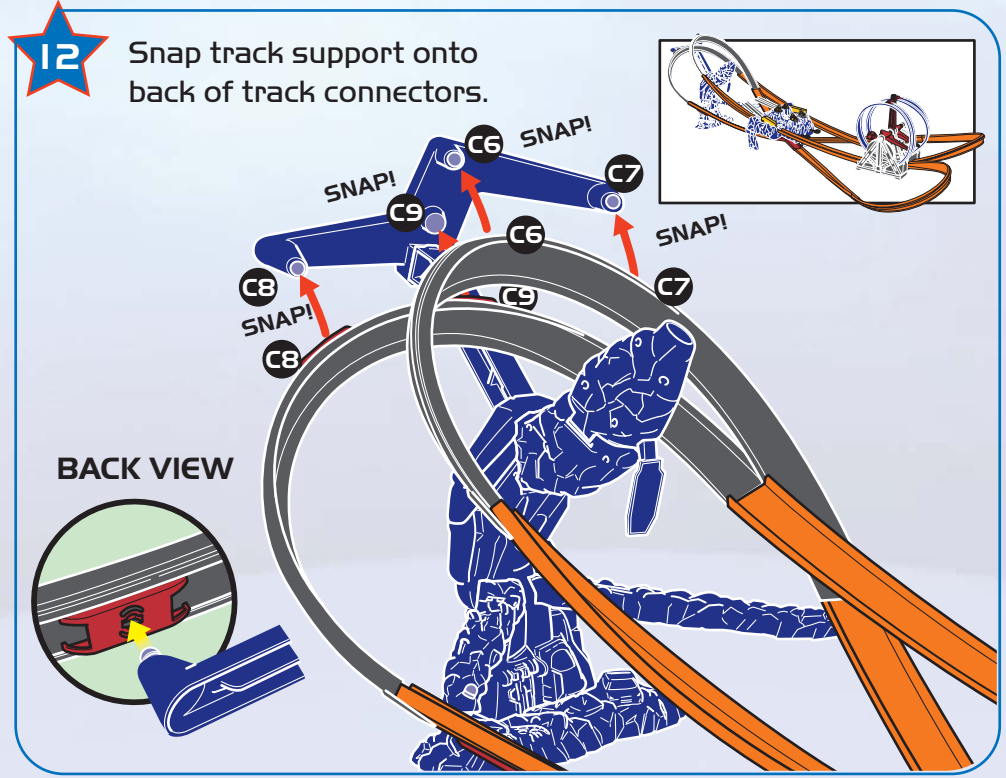
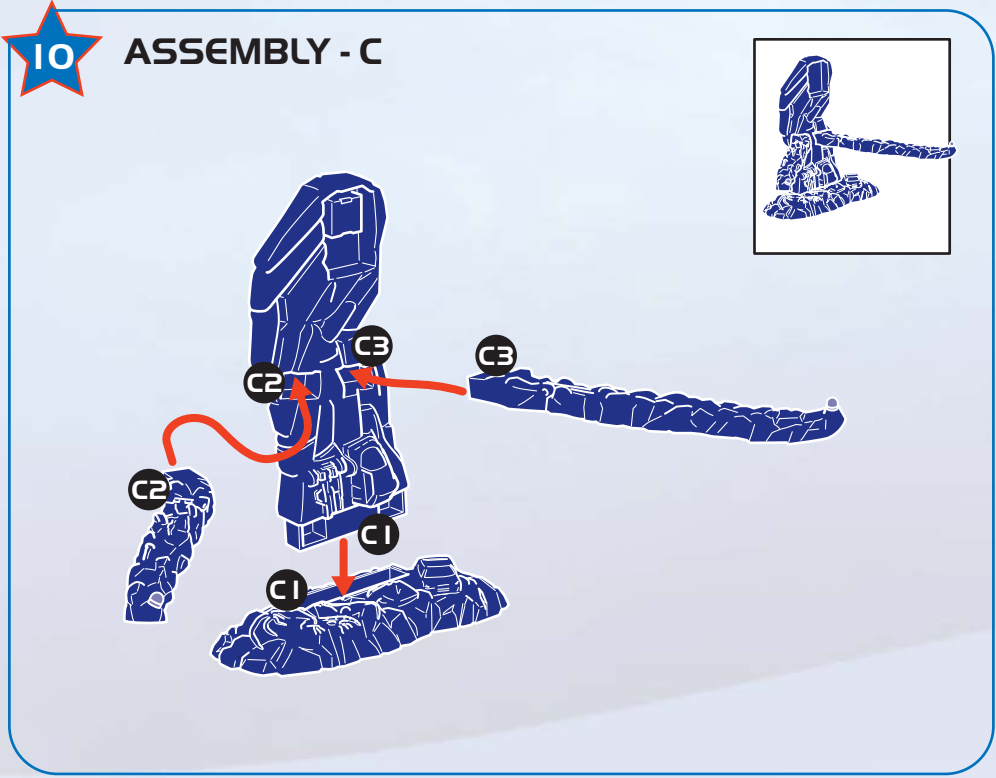
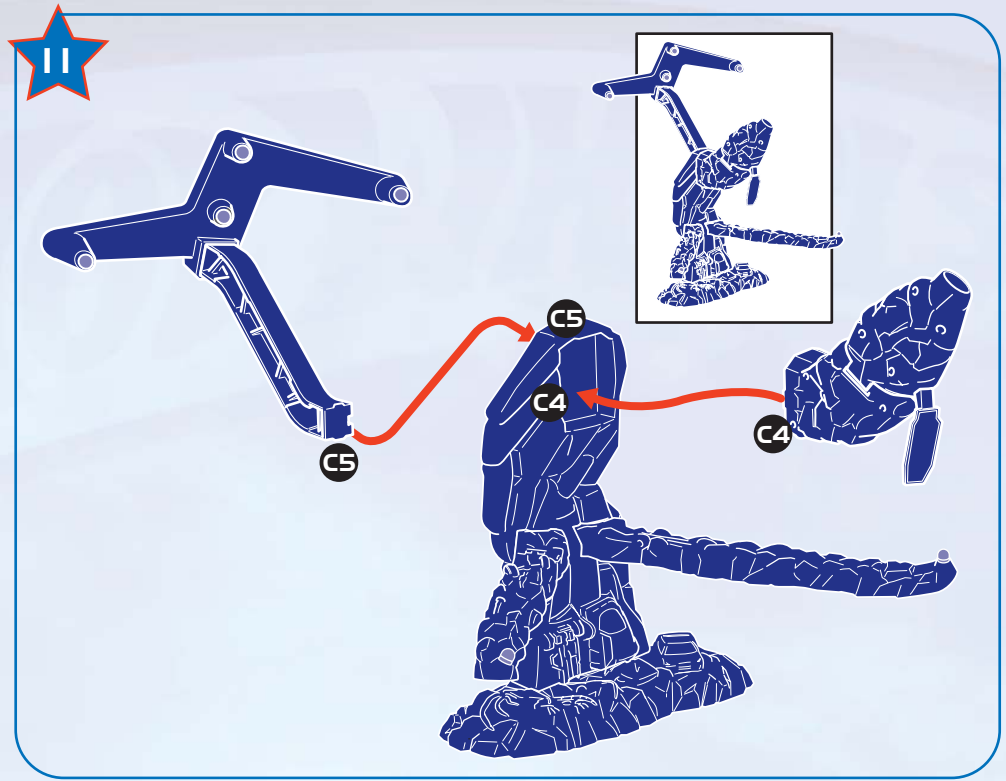
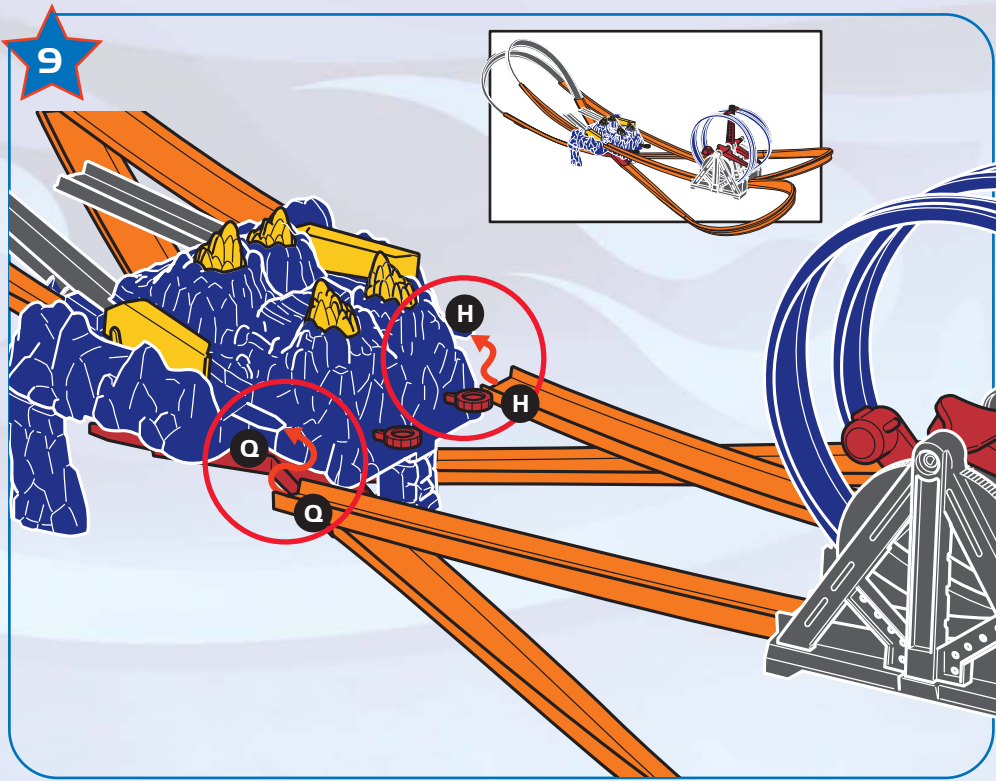

13

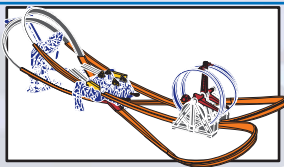

BOTTOM VIEW



BOTTOM VIEW

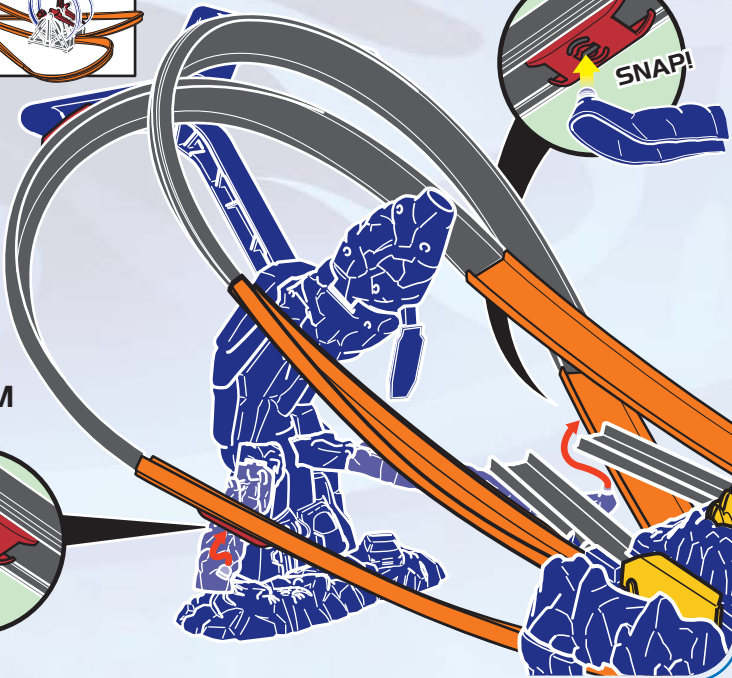

CONGRATULATIONS YOUR SET IS COMPLETE!

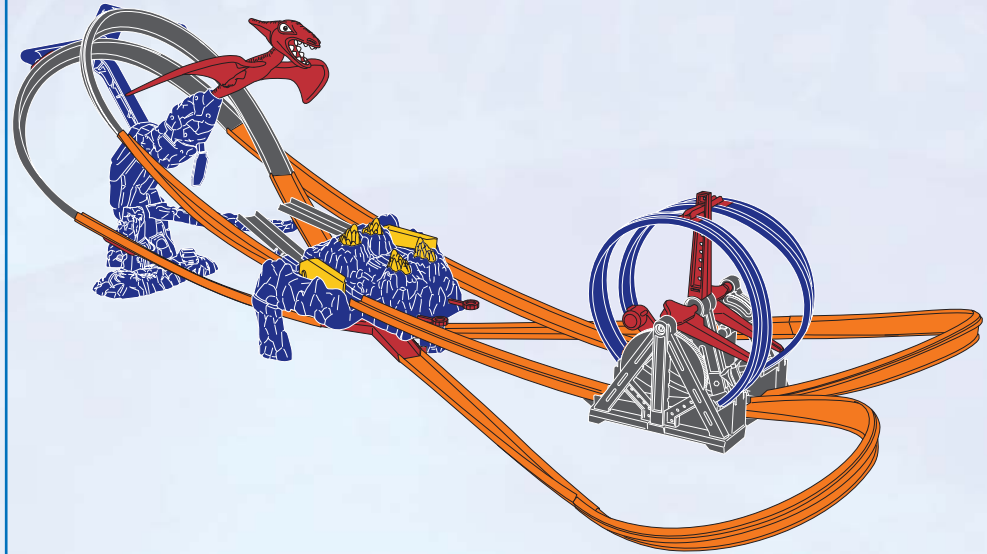

14

Insert pterodactyl's tail into cave until it locks into place.

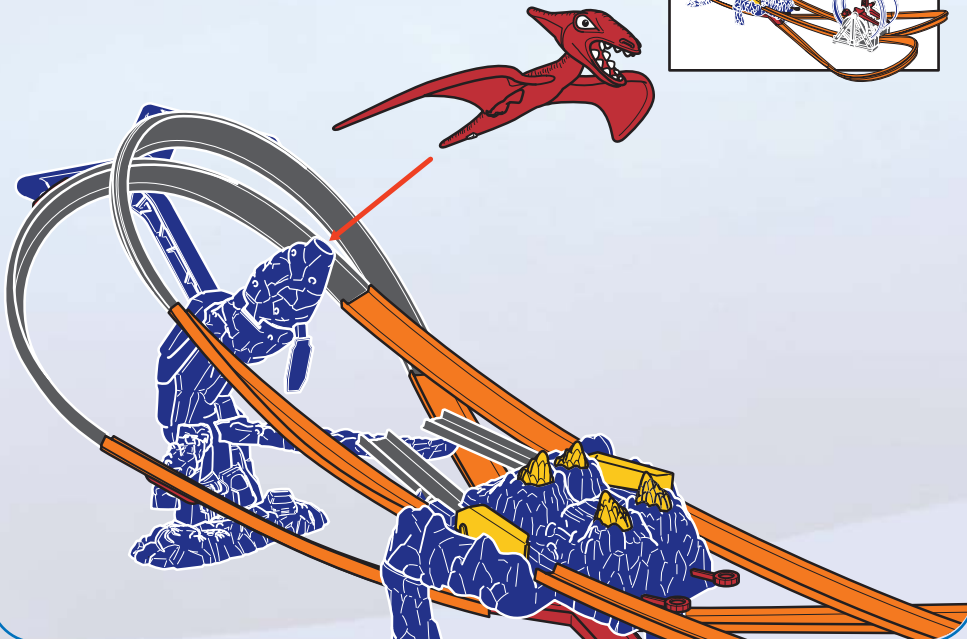
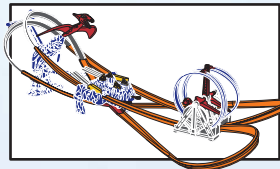

GET READY TO PLAY

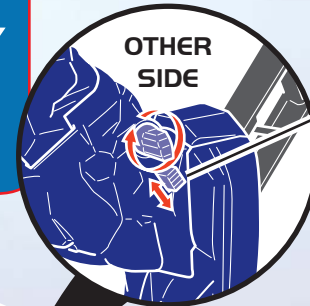

ON/OFF SWITCH
(UP=OFF / DOWN=ON)

With the switch in the OFF position, wind the knob clockwise. Keep switch OFF until ready to start play.



GET READY TO PLAY (CONTINUED)

Place cars
in front of
red levers
on inner
loop to start.

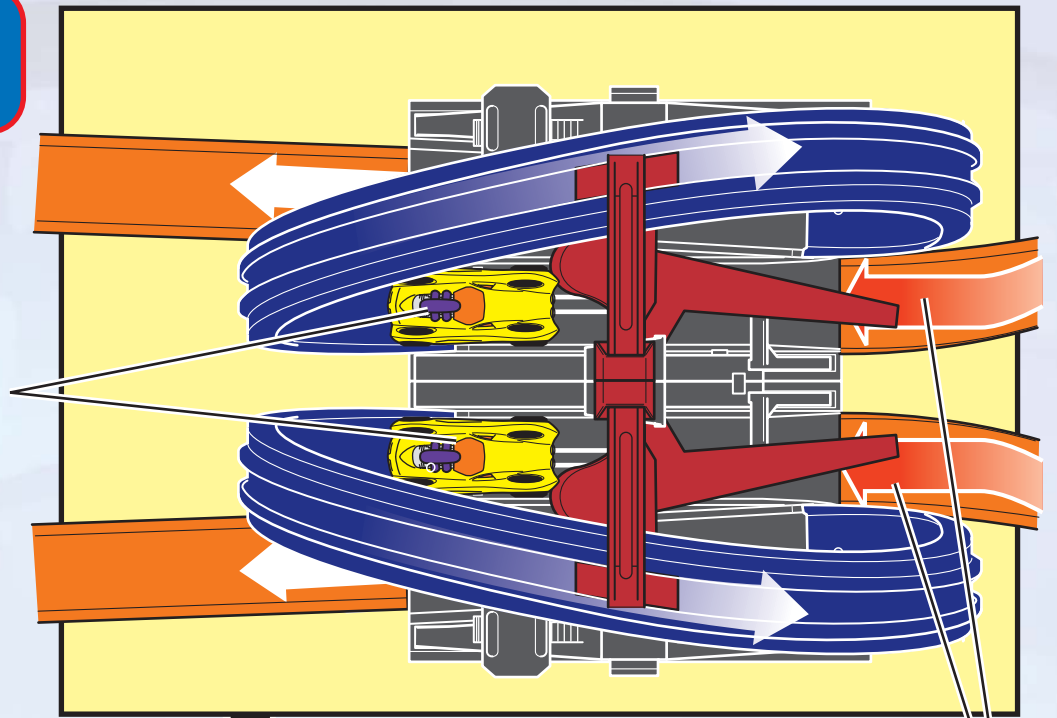

CAR
DIRECTION

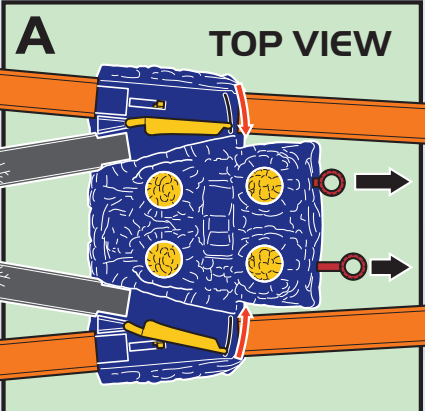
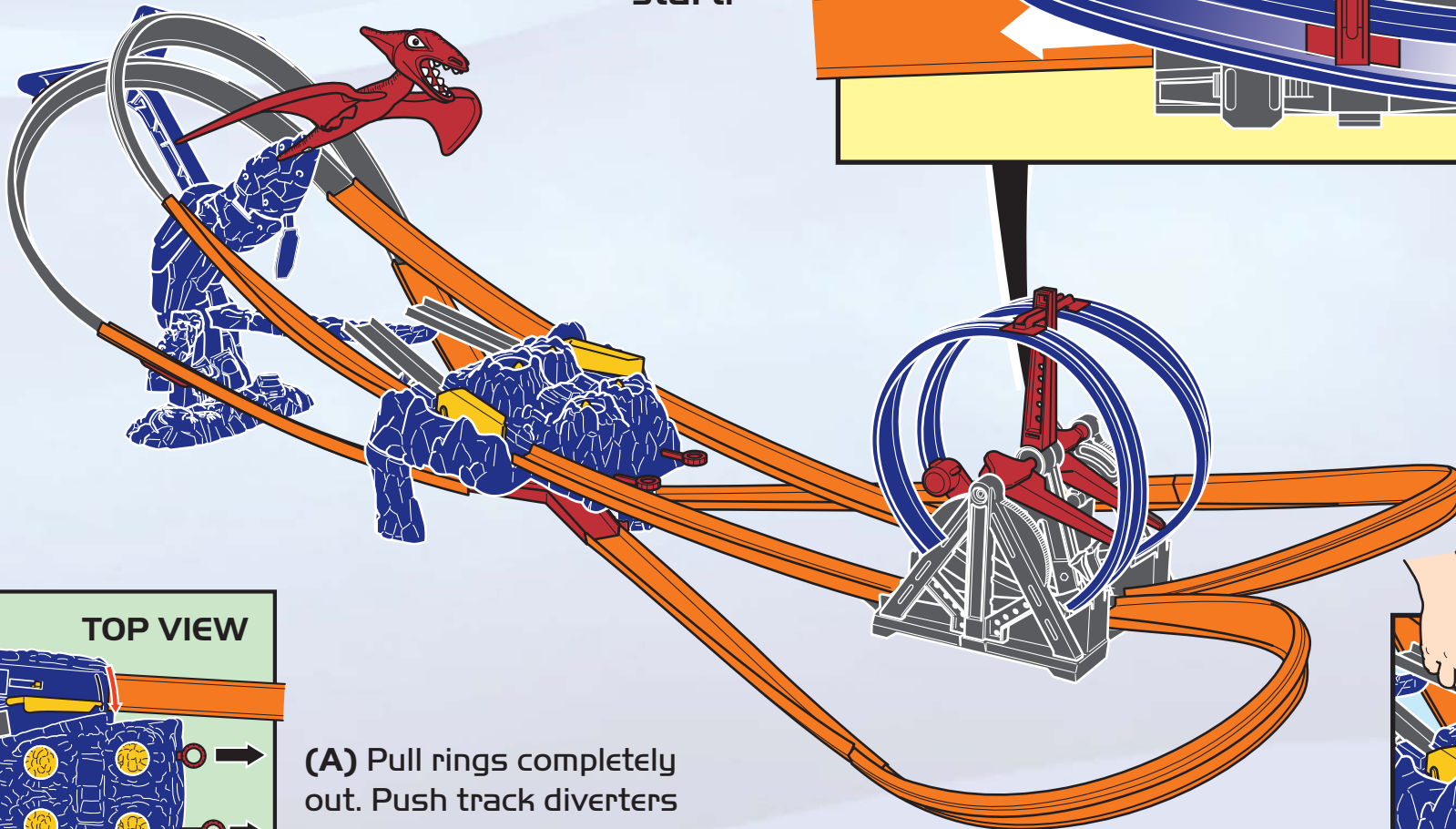

(A) Pull rings completely out. Push track diverters in as shown.

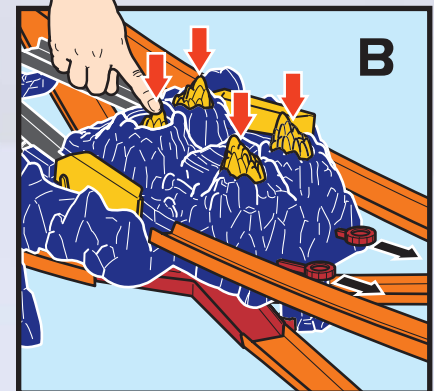

(B) Then push down all four volcano peaks until they lock.

TO PLAY 2-PLAYER

NOTE: 1-player game play is the same as the 2-player game play shown here you just won't have the head to head racing action.

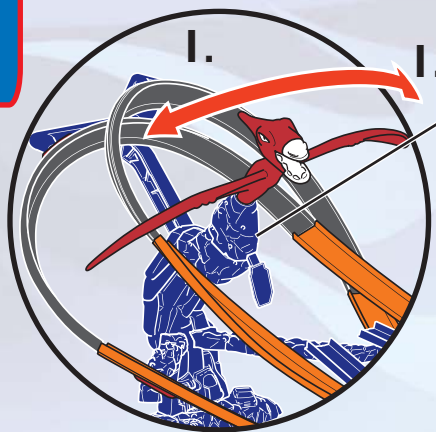

1. Push switch to the ON position to start. Watch as the pterodactyl moves from side to side.

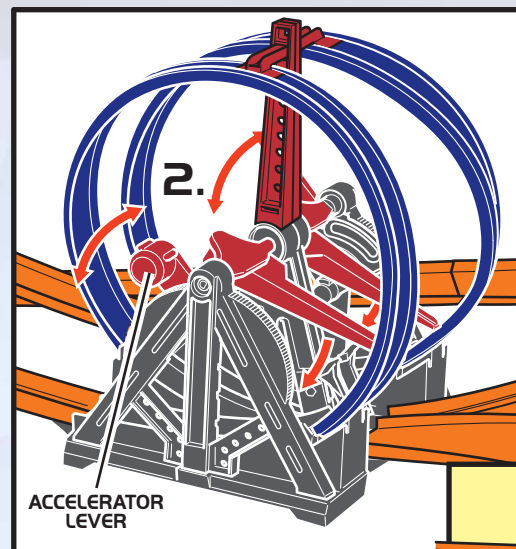

2. Place cars in front of red levers on inner loop to start.

3. Push down on accelerator levers to propel your car through the track.

TOP VIEW

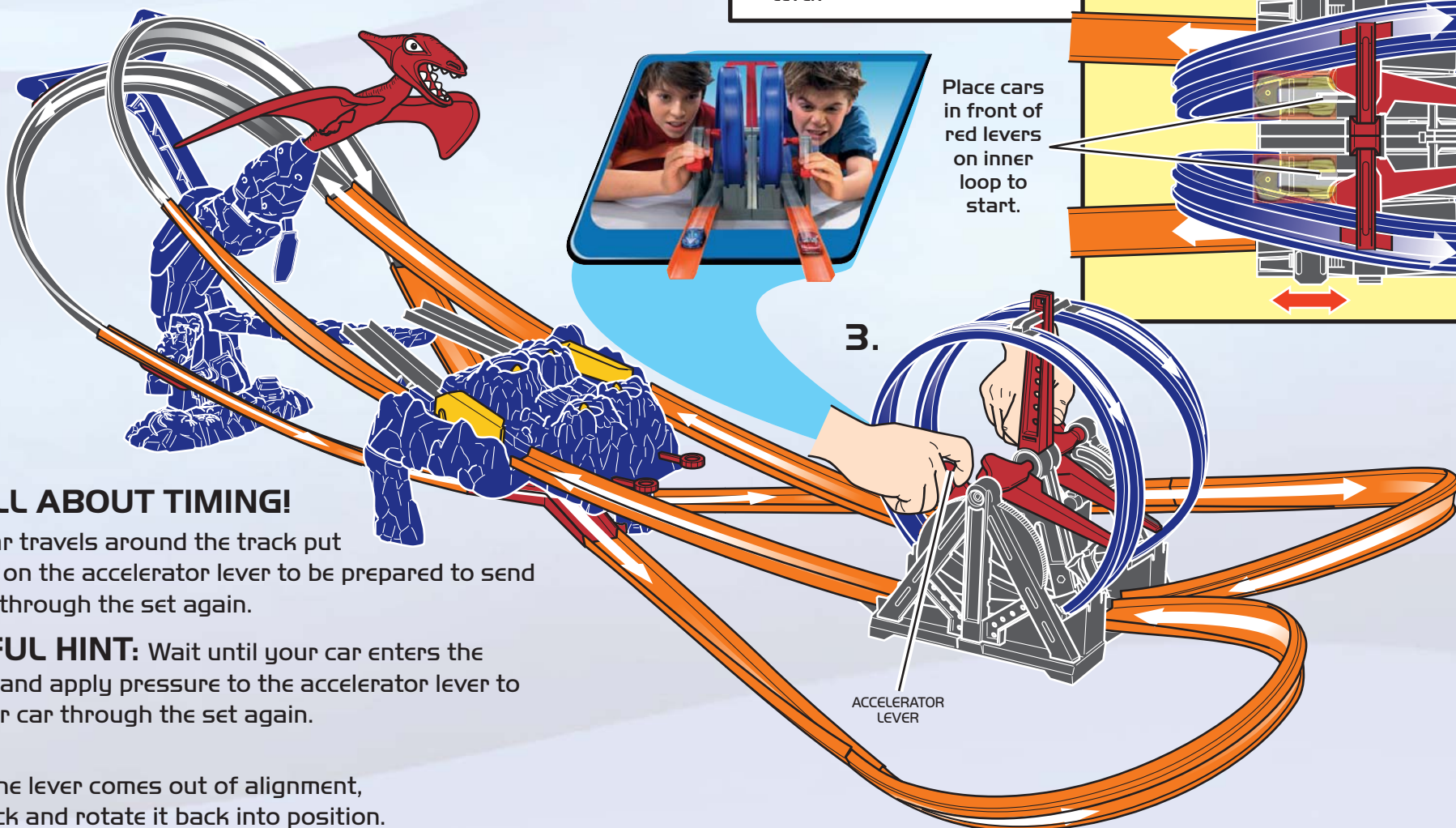
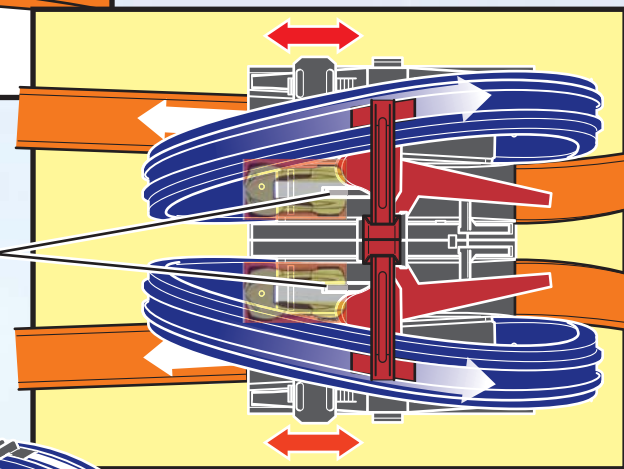

Place cars in front of red levers on inner loop to start.

3.

ACCELERATOR LEVER

IT'S ALL ABOUT TIMING!

As the car travels around the track put pressure on the accelerator lever to be prepared to send your car through the set again.

HELPFUL HINT: Wait until your car enters the launcher and apply pressure to the accelerator lever to send your car through the set again.

TIP: If the lever comes out of alignment, pull it back and rotate it back into position.

TO PLAY (CONTINUED)

Continue sending your car through the track. Once you complete 3 laps through the volcanoes, one volcano will erupt. Complete 6 laps and the other volcano will erupt and trigger the track diverter. The next lap will send your car towards the pterodactyl.

The first one to hit the target trigger and send the pterodactyl flying **WINS!**

If the 6 laps are not completed by the time the pterodactyl stops moving players can stop playing, rewind the pterodactyl and keep playing until someone wins.

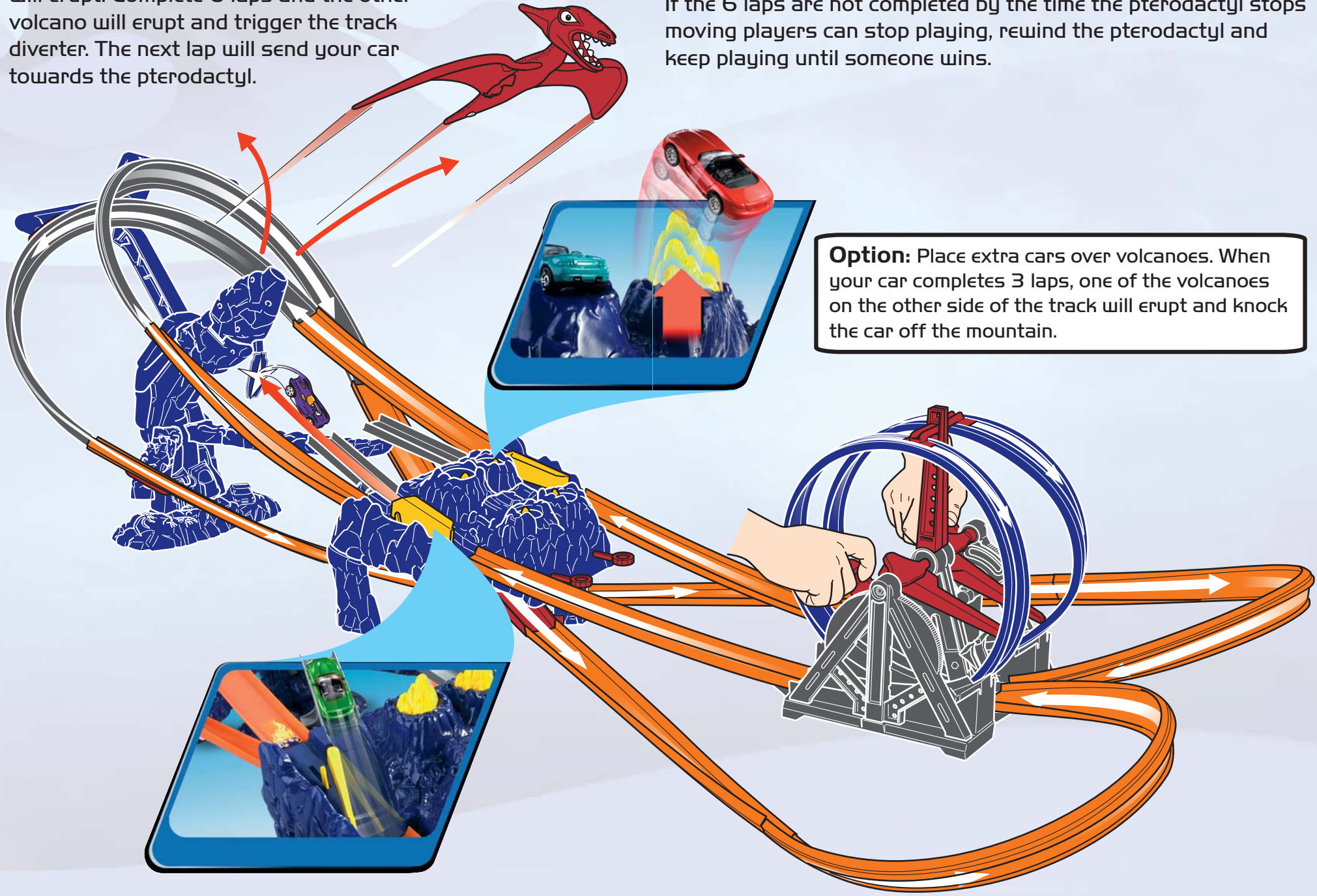

Option: Place extra cars over volcanoes. When your car completes 3 laps, one of the volcanoes on the other side of the track will erupt and knock the car off the mountain.

STORE YOUR SET UNDER YOUR BED!

1. Unsnap track from support and remove support arm.

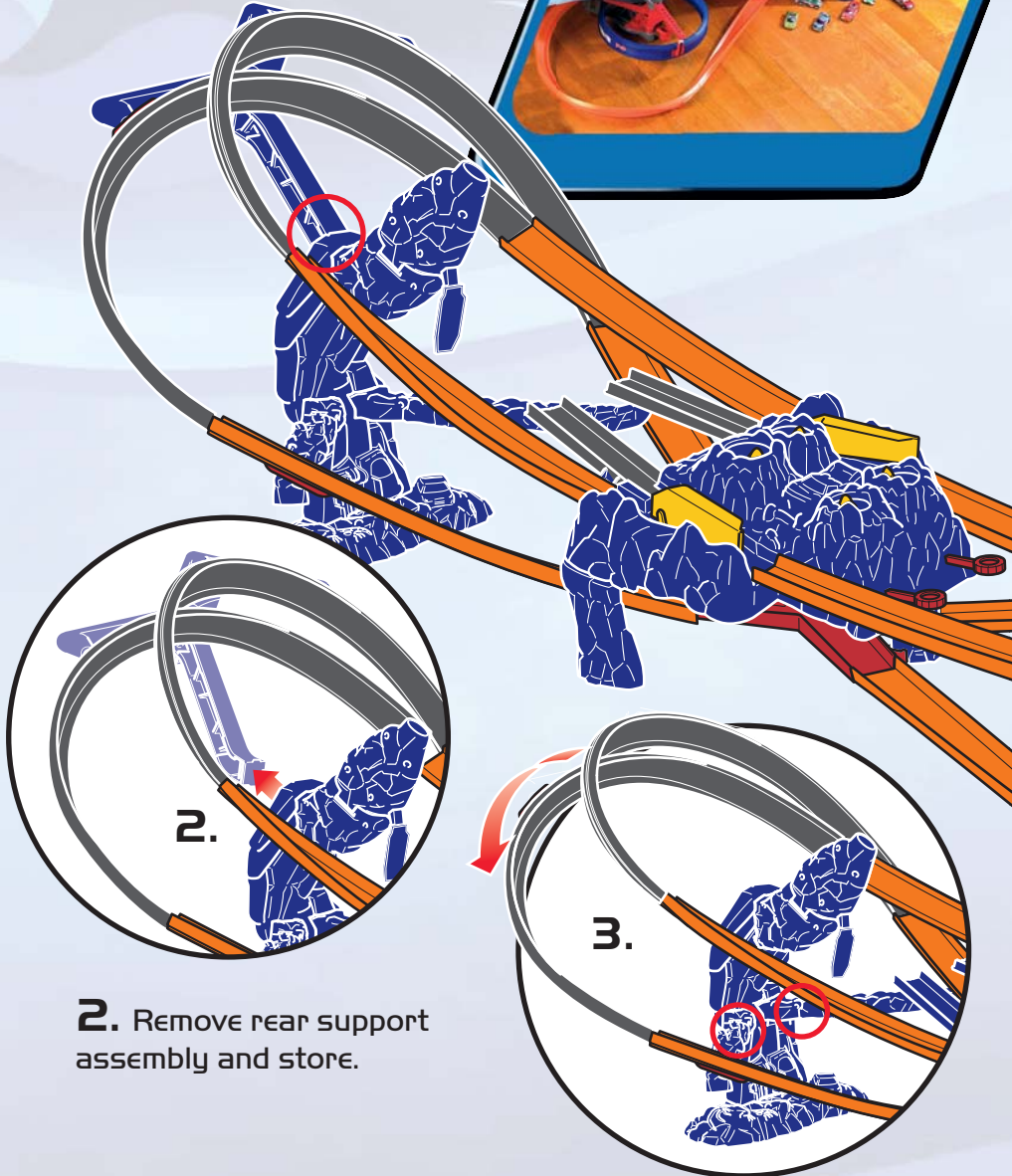

2. Remove rear support assembly and store.

3. Drop curve track assembly and tilt perch assembly backward until it lies flat.

NOTE: support arms are hinged to allow perch to bend forward.

4. Unsnap the two halves of the launcher/loop and fold down flat as shown.

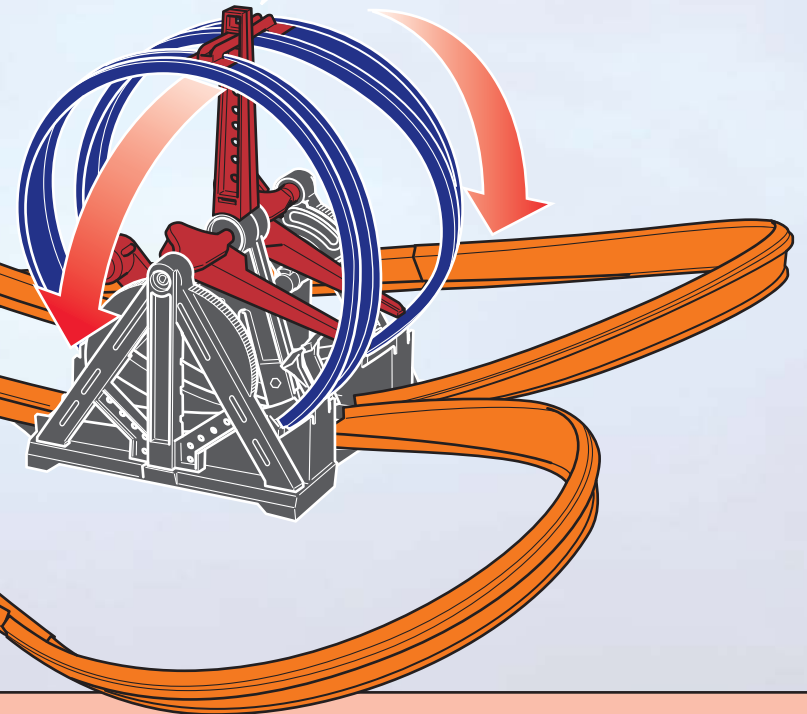
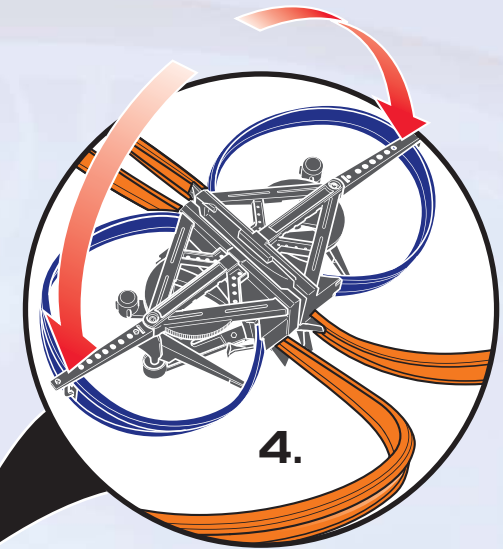

Animated assembly instructions available online! Go to: http://www.hotwheels.com/J3893_Terrordactyl



Refer to numbers on parts and contents page to help with assembly.



We want to hear your feedback on this toy. Go to: <http://service.mattel.com/us/>