



**Trike**



**Bike**

## Warnings and Caution

### **WARNING**

#### To avoid serious injury:

- Protective equipment should be worn. Use a bicycle helmet when in the bike mode.
- Adult supervision is required.
- Never use near cars and other motor vehicles, near streets, steps, sloped driveways, hills, roadways, alleys, swimming pools or other bodies of water.
- Always wear shoes.
- Never allow more than one rider.

### **CAUTION**

This product contains small parts in its unassembled state. Adult assembly is required.

## Consumer Information

- Please keep this instruction sheet for future reference, as it contains important information.
- Adult assembly is required.
- Tools needed for assembly: Phillips Screwdriver, Hammer and Scrap Block of Wood (all not included).
- Age: 2 years and up.
- Weight Limit: 50 lbs (23 kg).

Visit us on line at [www.service.fisher-price.com](http://www.service.fisher-price.com)

Call Fisher-Price® Consumer Relations, toll-free at **1-800-432-5437**, 9 AM – 7 PM EST Monday through Friday and 11 AM – 5 PM EST Saturday. Hearing-impaired consumers using TTY/TDD equipment, please call **1-800-382-7470**. Write to us at: Fisher-Price® Consumer Relations, 636 Girard Avenue, East Aurora, New York 14052.

#### For countries outside the United States:

##### **CANADA**

Questions? **1-800-432-5437**. Mattel Canada Inc., 6155 Freemont Blvd., Mississauga, Ontario L5R 3W2; [www.service.mattel.com](http://www.service.mattel.com).

##### **GREAT BRITAIN**

Mattel UK Ltd, Vanwall Business Park, Maidenhead SL6 4UB. Helpline: 01628 500303; [www.service.mattel.com/uk](http://www.service.mattel.com/uk).

##### **AUSTRALIA**

Mattel Australia Pty. Ltd., 658 Church Street, Locked Bag #870, Richmond, Victoria 3121 Australia. Consumer Advisory Service 1300 135 312.

##### **NEW ZEALAND**

16-18 William Pickering Drive, Albany 1331, Auckland.

##### **ASIA**

Mattel East Asia Ltd, Room 1106, South Tower, World Finance Centre, Harbour City, Tsimshatsui, HK, China.

## Important Safety Information

- Please use this product with caution, as it requires skill to operate safely to avoid falls, collisions, and injuries to yourself and others.
- This product is intended for outdoor use on smooth, paved surfaces.
- Never ride at night.
- Make sure your child learns how to stop safely.
- It is a good practice to start training children very young regarding the importance of helmet use. When children are older and riding bicycles and faster vehicles, it is important that they use a helmet each and every time they ride. For this reason, even while riding a tricycle, it is a good idea to familiarize your child with helmet use, so that it becomes a habit for life. Choose a helmet that complies with requirements of the applicable certifying agency for bicycle helmets.
- Your child must always wear a bicycle helmet when using this product in the bike mode. Helmets reduce the energy of some impacts, minimizing or preventing head injuries. Make sure your child's helmet has a label stating/certifying conformance with the applicable certifying agency and includes the intended age requirement for use with a child. In addition, children ages 1 to 5 years require helmets specifically designed and labeled for younger children. These helmets cover a larger portion of the head and provide more protective coverage than other helmets for older persons.
- For maximum protection during an impact, the helmet must be properly secured to your child's head. The helmet must have a strap that goes under the chin with a buckle that stays securely fastened. The helmet should be worn level/low on the forehead, not tilted back. The chin strap should be adjusted so there is no slack and it is firmly buckled (please refer to the helmet manufacturer's instructions). After securing the helmet to your child's head, test to be sure that the strap stays tight, the buckle remains secure and the helmet cannot be removed from your child's head by twisting or pulling the helmet.
- Remind your child to remove the helmet when playing on any kind of playground equipment or any place where the helmet may present a risk of strangulation.
- If the helmet is involved in a crash, replace it or have it examined by the manufacturer before reuse.

## Care

- Periodically check the plastic parts and if broken or cracked, dispose of them properly. Contact Fisher-Price® Consumer Relations for replacement information.
- Check all fasteners before every ride to be sure they are tight. If the fasteners are not tight, tighten them as necessary.
- To clean, use a mild soap and water solution and clean cloth. Rinse clean with water to remove soap residue.

# Parts

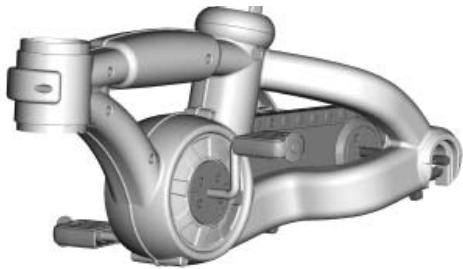

Frame



Lower Steering Stop



2 Retainers



Upper Steering Stop



2 Wheel Bushings

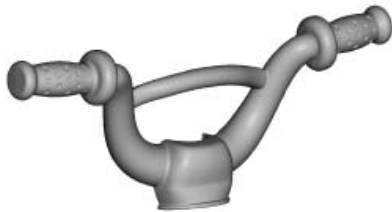

Handlebar



Fork



Front Axle



2 Rear Wheels



Front Wheel



Seat



Seat Pin

- Please save all packaging material until assembly is complete to ensure that no parts are discarded.
- Please wipe each part with a clean, dry cloth before assembly.

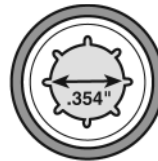

.354 Cap Nut - 2



#8 x  $\frac{3}{4}$ " Screw - 6



#8 x  $2\frac{1}{4}$ " Screw - 1

- All fasteners shown are actual size.
- Tighten and loosen all screws with an Phillips screwdriver. Do not over-tighten the screws.
- We've included extra fasteners for your convenience!

# Assembly

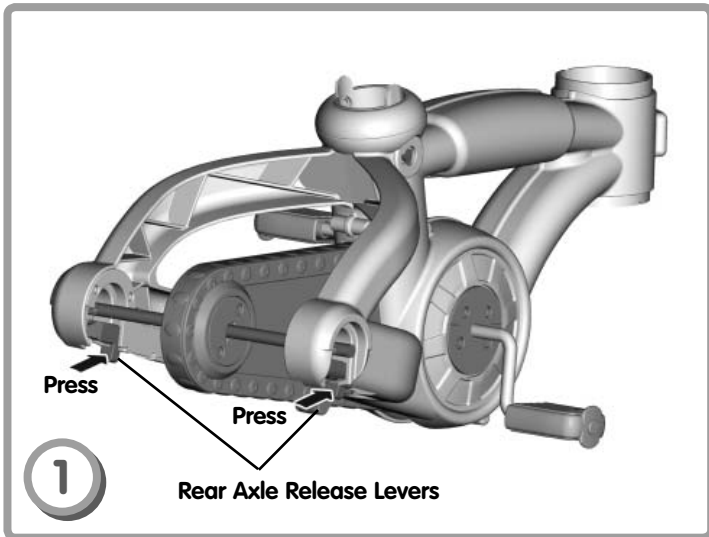

- Press the rear axle release levers on the back end of the frame.

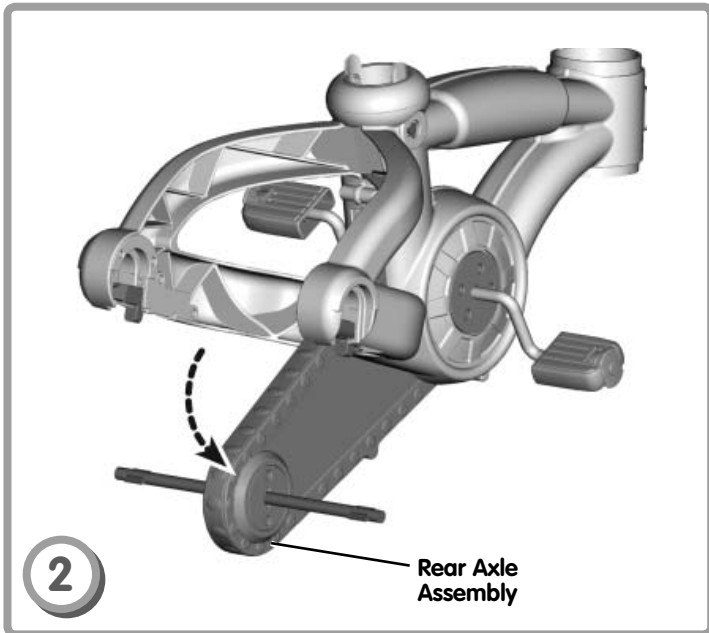

- Lower the rear axle assembly.

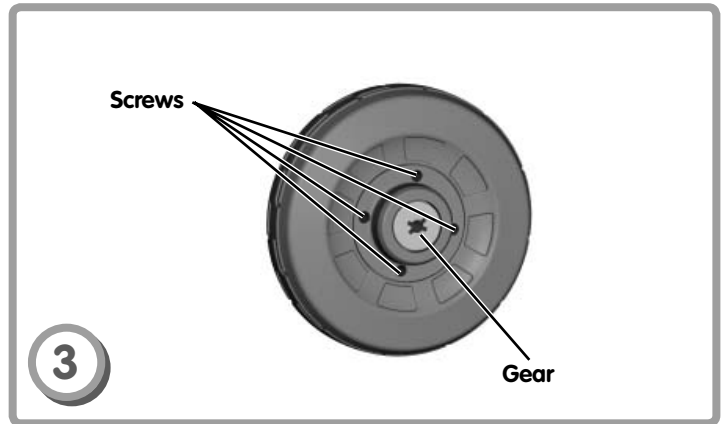

- Locate the four screws on each rear wheel. These **screws should face out** when assembling the rear wheels to the frame.
- Make sure the gear in the center of each rear wheel is flush with the outside surface of the rear wheel.

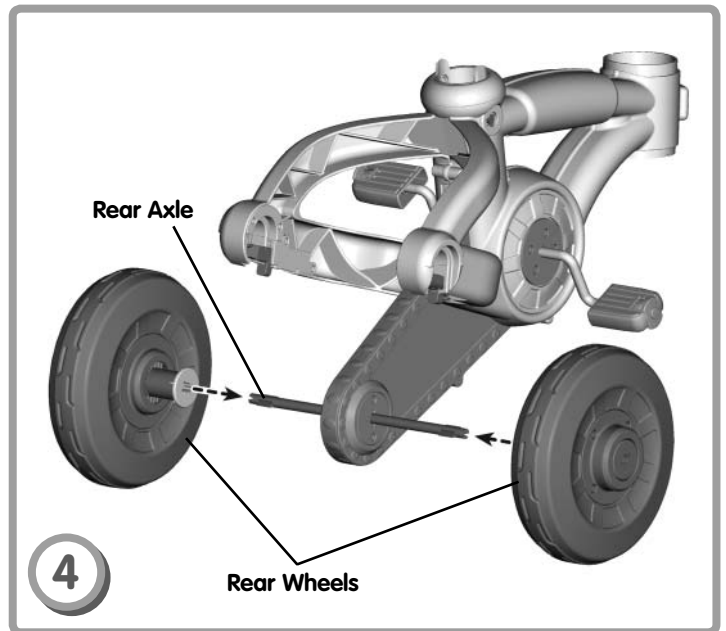

**Hint:** After assembly is complete, the Trike2Bike will be ready to ride as a Trike.

- Fit and slide the rear wheels onto the ends of the rear axle.

# Assembly

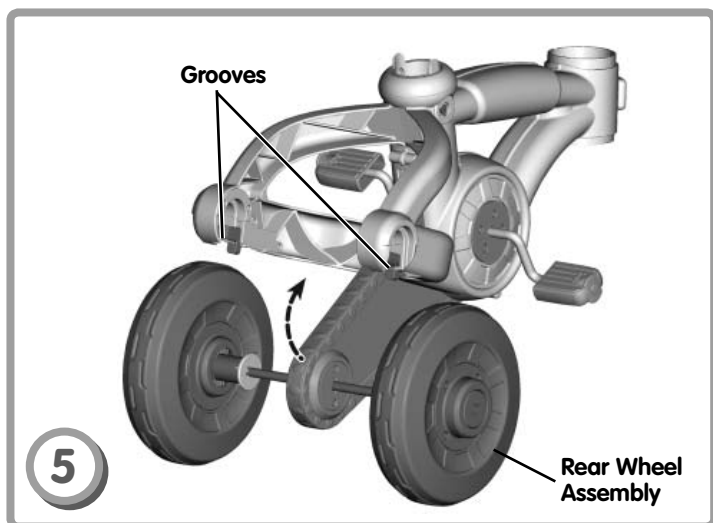

- Lift and **"snap"** the rear wheel assembly into the grooves in the back end of the frame.
- Pull down on the rear wheel assembly to be sure it is secure.

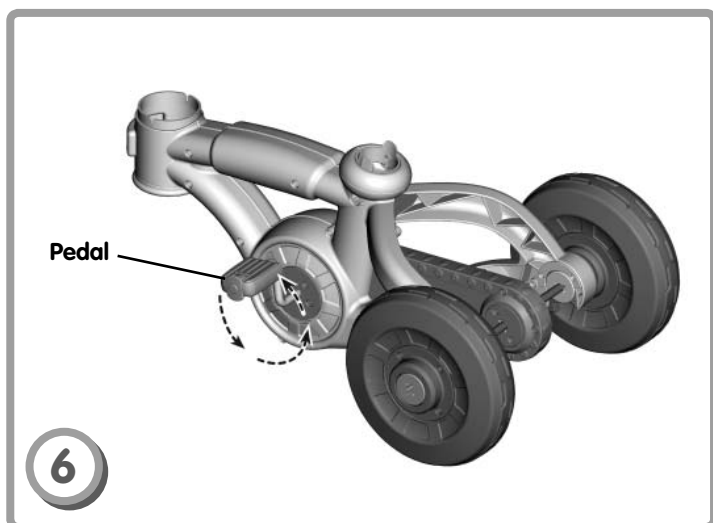

- Check to be sure you have assembled the rear wheels to the frame properly. First, turn the pedals. If one of the rear wheels turns, you have assembled them correctly. If not, please remove the rear wheels and follow assembly steps 3-6.

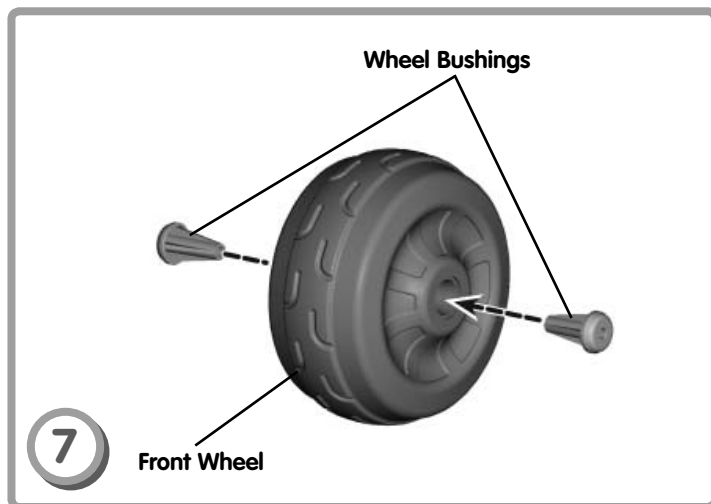

- Fit a wheel bushing into the center hole in each side of the front wheel.

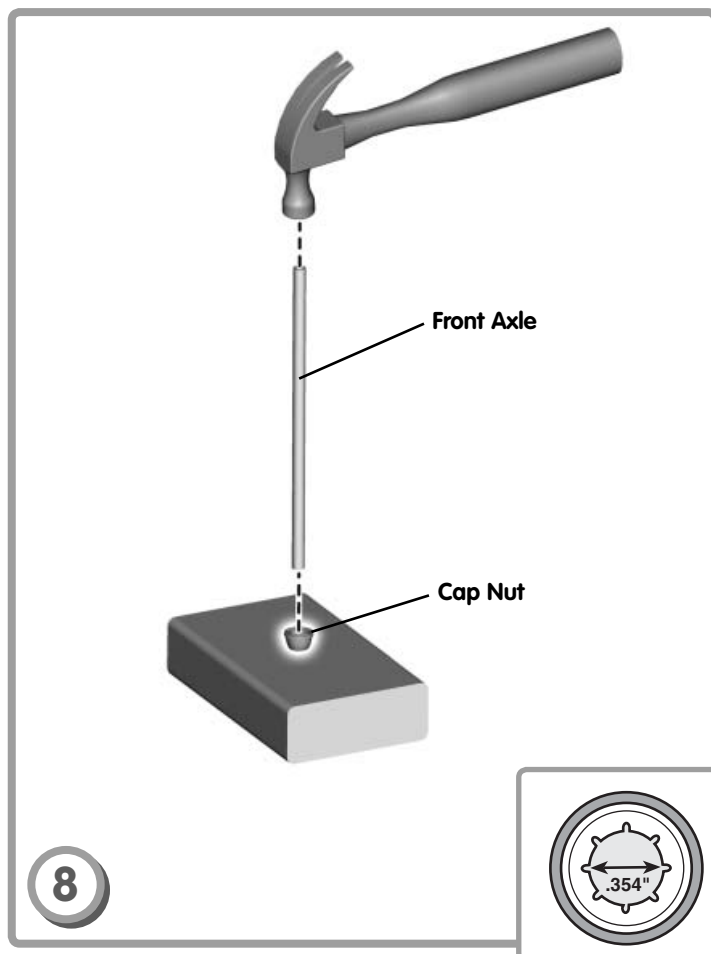

- Place one end of the front axle into a cap nut. Tap the end of the front axle with a hammer. Make sure the cap nut is securely attached to the front axle.

**Hint:** You may want to place a scrap block of wood underneath the cap nut to protect the assembly surface.

# Assembly

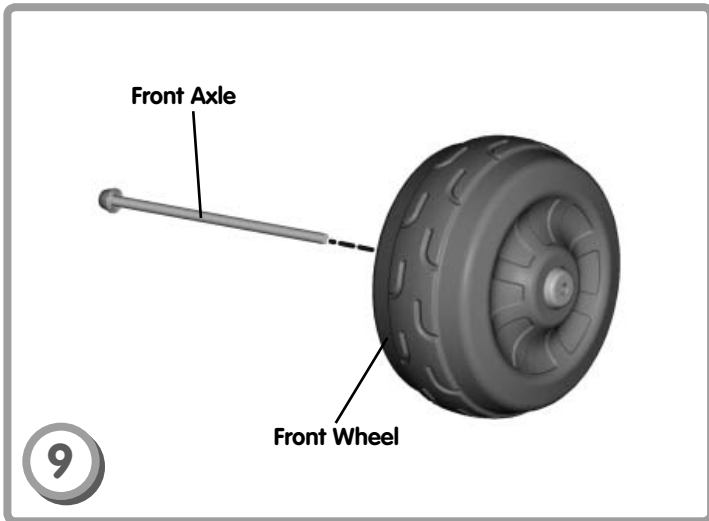

- Slide the front axle through the center hole in the front wheel.

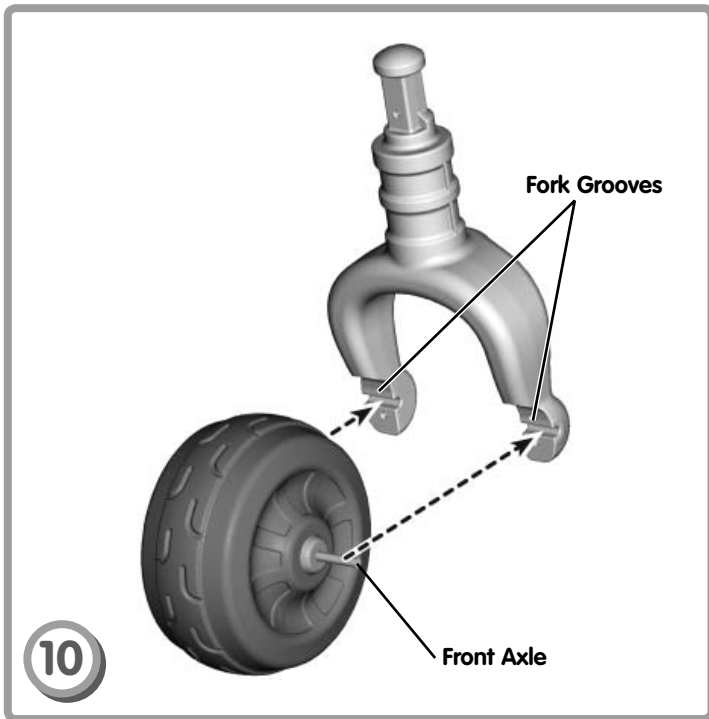

- Fit the ends of the front axle into the grooves in the fork.

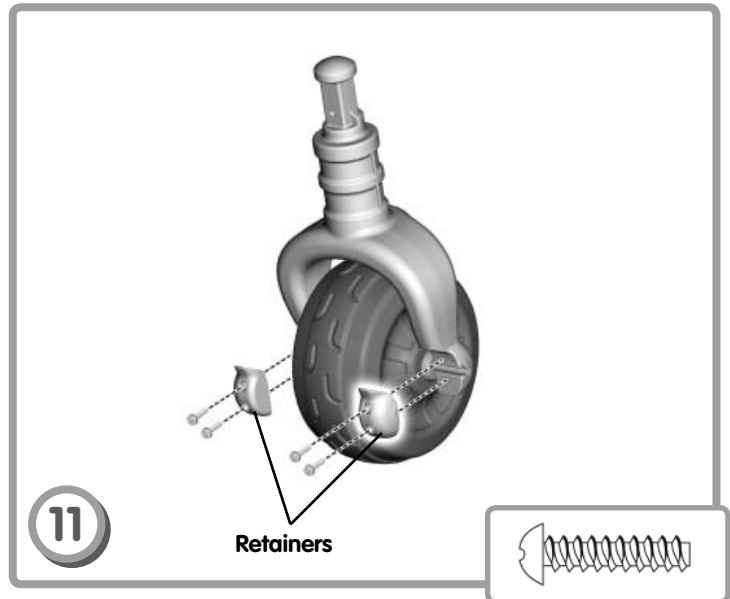

- Fit the retainers over the ends of the front axle and onto the fork.
- Insert two #8 x  $\frac{3}{4}$ " screws into each retainer and tighten.

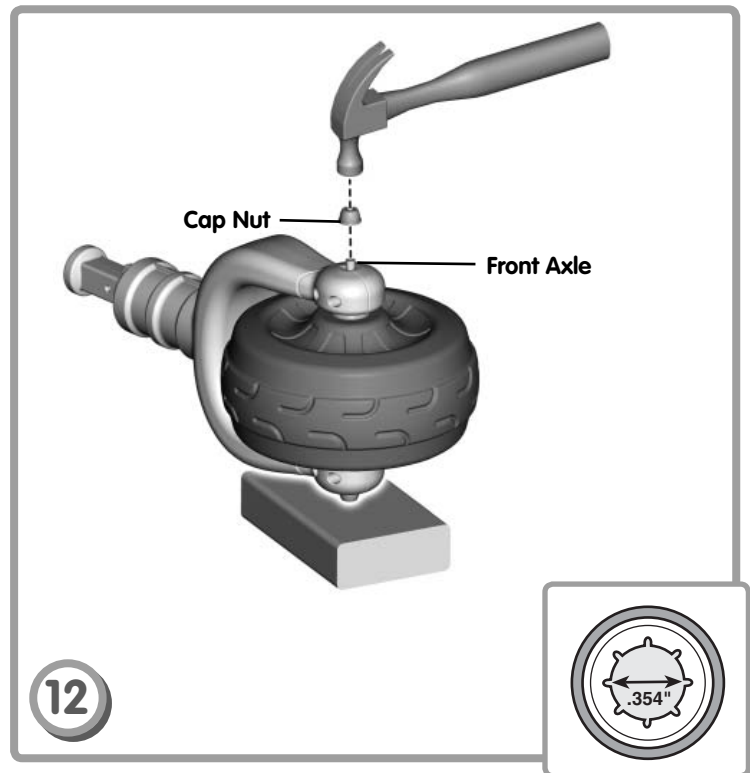

- Turn the fork assembly on its side with the front axle facing up.
- Place the remaining cap nut onto the end of the front axle.
- Tap the cap nut with a hammer to secure it in place. Pull on the cap nut to be sure it is secure.
- Set the fork assembly aside.

**Hint:** You may want to place a scrap block of wood underneath the assembly to protect the assembly surface.



# Assembly

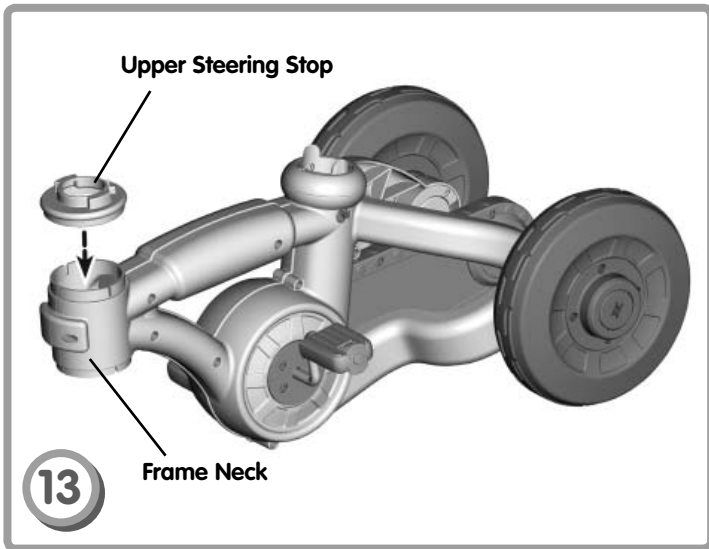

- Fit the upper steering stop to the top of the frame neck.

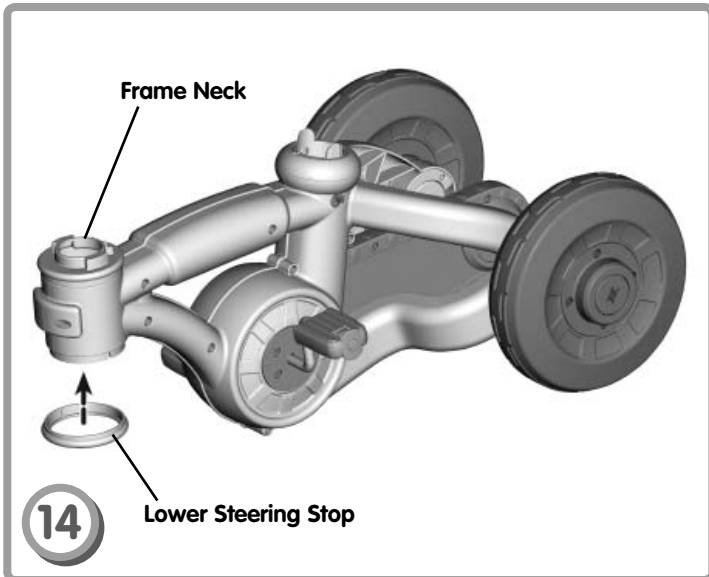

- Fit the lower steering stop to the bottom of the frame neck.

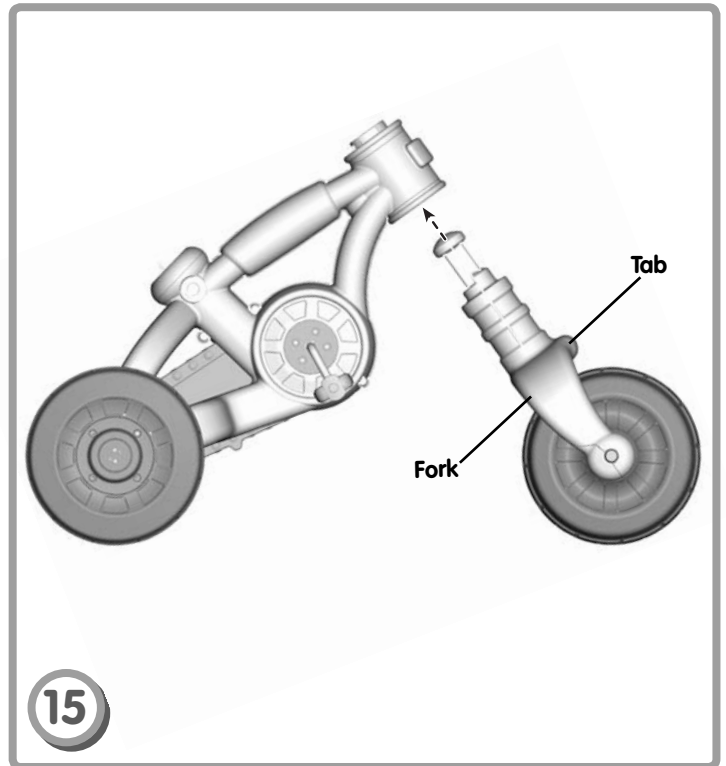

- Position the fork so that the tab faces forward.
- Fit the fork up through the hole in the frame neck.

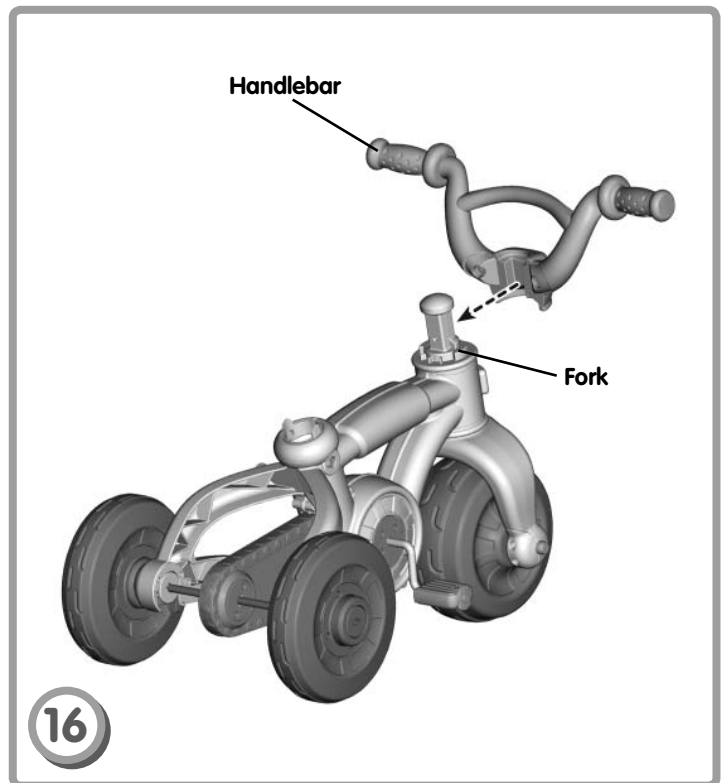

- Fit the handlebar to the front of the fork.

# Assembly

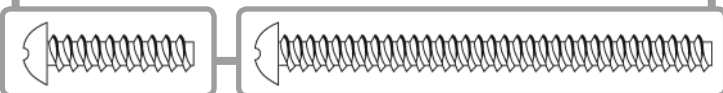
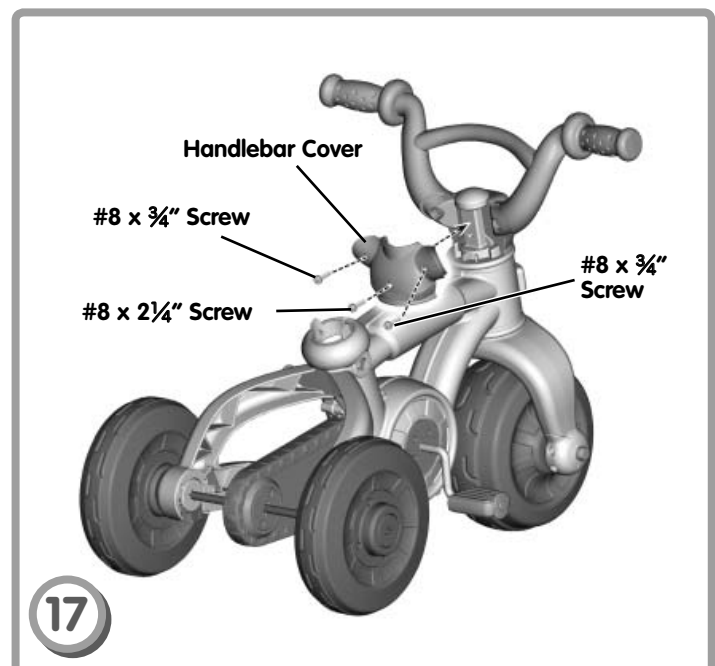

- Fit the handlebar cover to the back of the fork and the handlebar.
- Fit two **#8 x 3/4"** screws through the **outside holes** in the handlebar cover. Tighten the screws.
- Fit the **#8 x 2 1/4"** screw through the hole in the **center** of the handlebar cover. Tighten the screw.

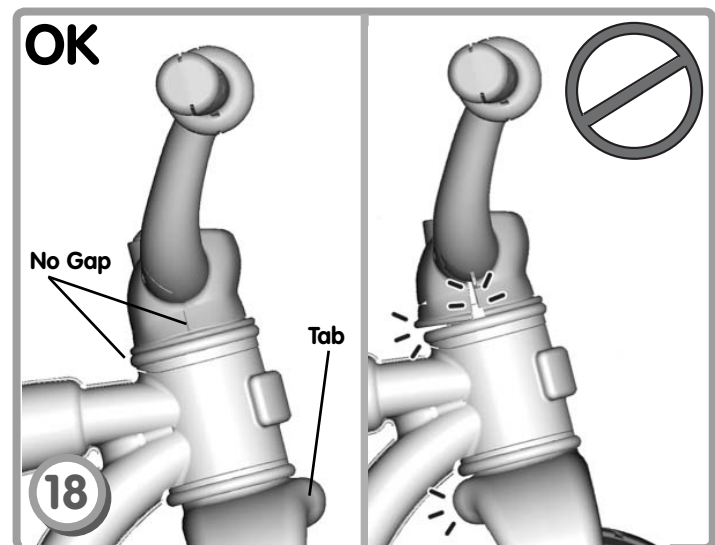

- Check to be sure you have assembled the fork to the frame properly. When assembled correctly, the tab faces forward and there are no gaps between the handlebar and the handlebar cover. If the tab faces the rear of the assembly and there are no gaps between the handlebar and handlebar cover, remove the screws and review assembly steps 15 - 17.

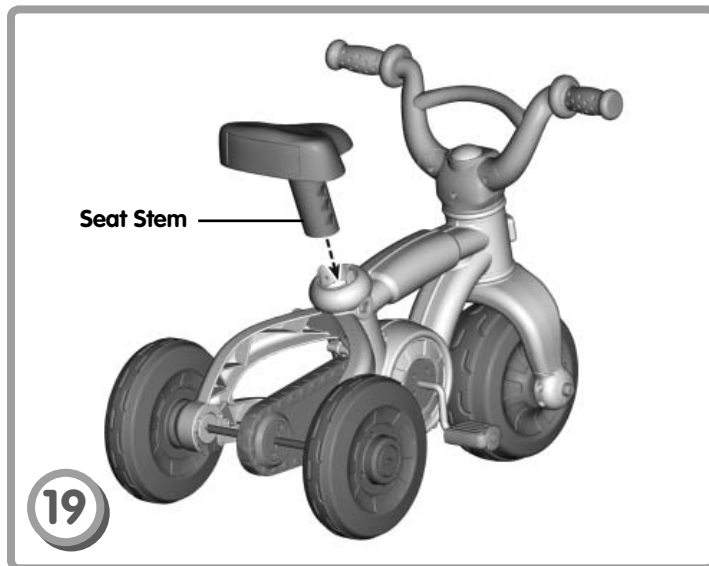

- Fit the seat stem into the large hole in the top of the frame.

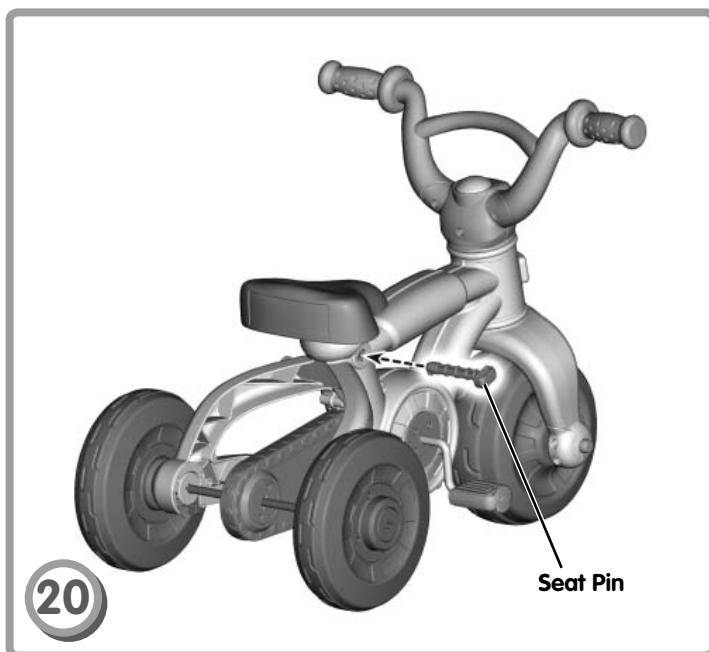

- Slide the seat pin into the hole on one side of the frame, and through a hole in the seat stem.

**Hint:** The seat is designed to be adjustable to your child's size. Have your child sit on the seat and check the foot to pedal distance. Adjust the seat up or down for your child's comfort!



# Convert to Bike

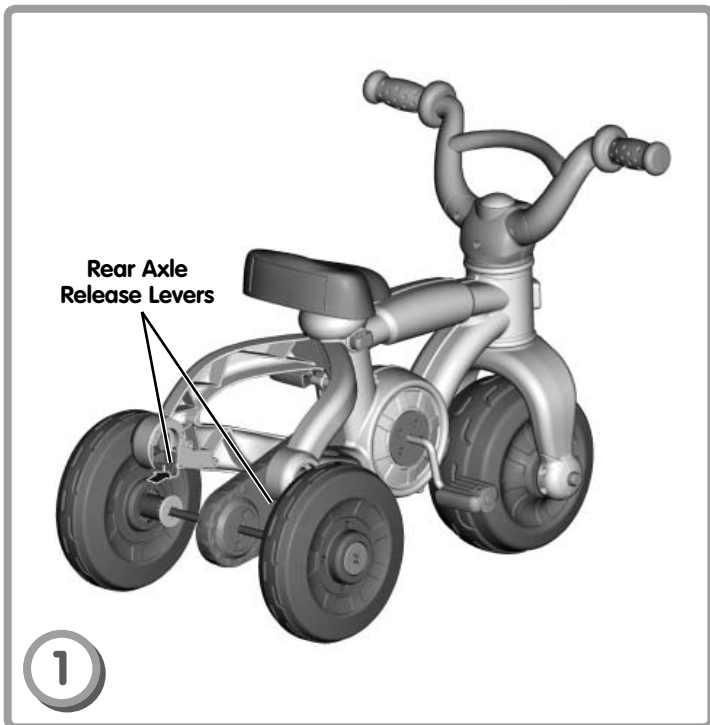

- Press the rear axle release levers on the back end of the frame.

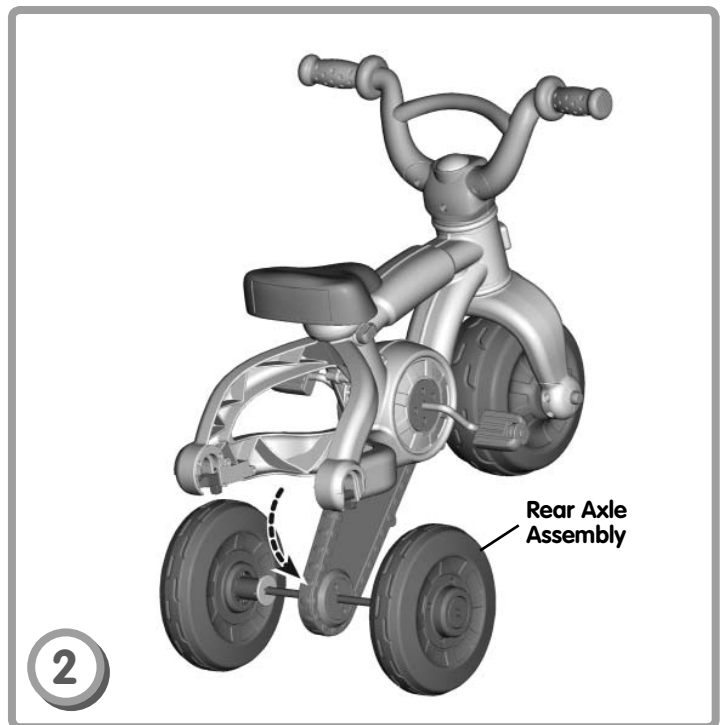

- Lower the rear axle assembly.

## Convert to Bike

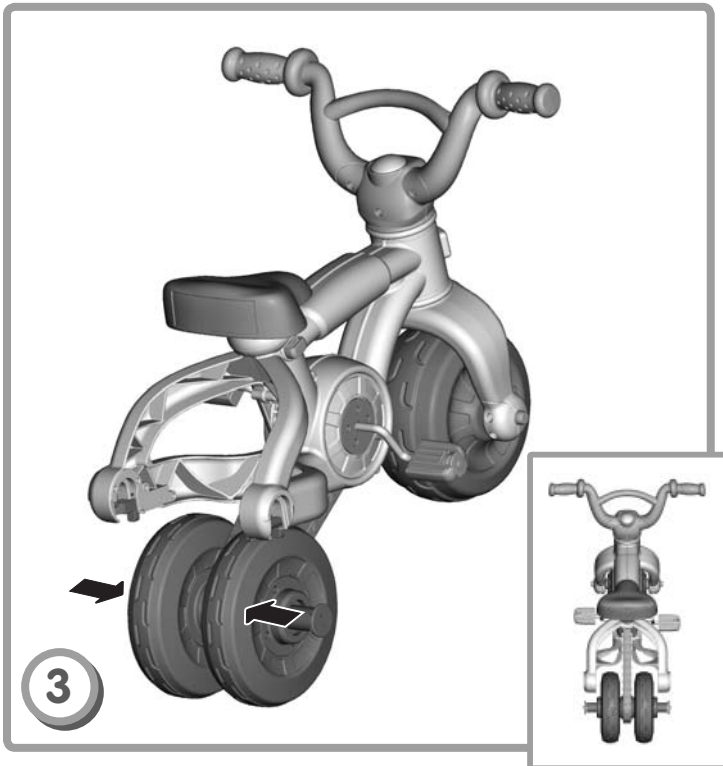

- Push the rear wheels together.

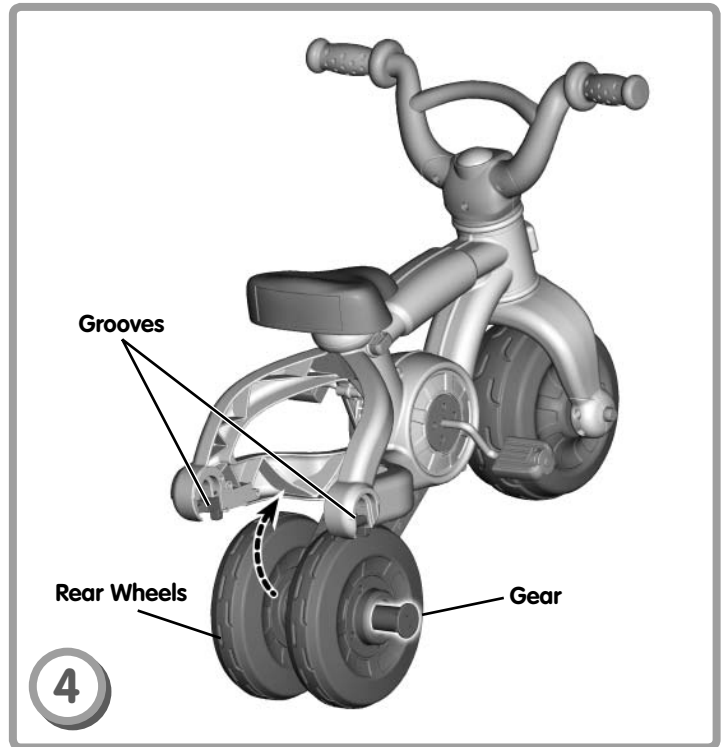

- Lift the rear wheels until the gears on the outside of rear wheels **"snap"** into the grooves in the frame.
- Check to be sure the rear wheels are secure, by pulling down on them. If they are not secure, review these instructions carefully and try again.

## Convert to Trike

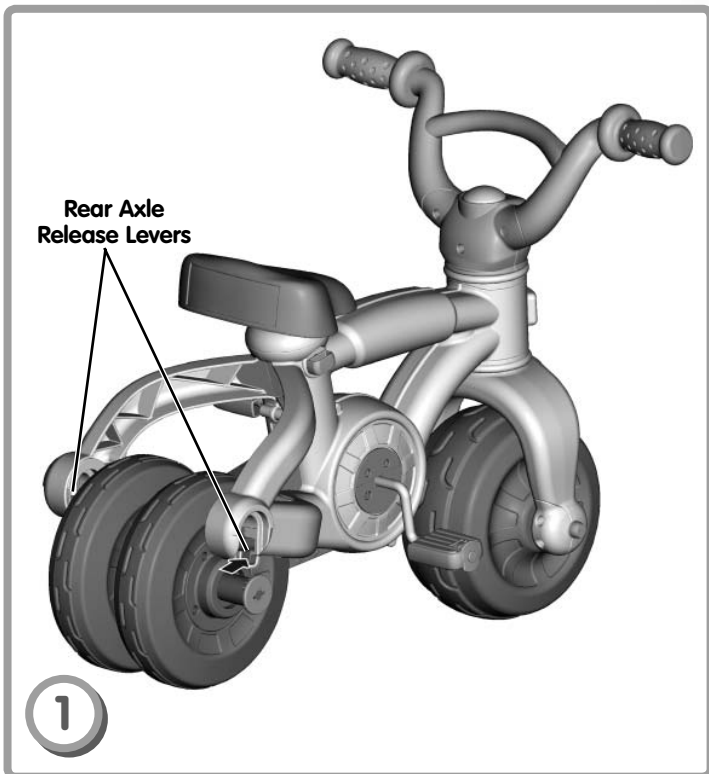

- Press the rear axle release levers on the back end of the frame.

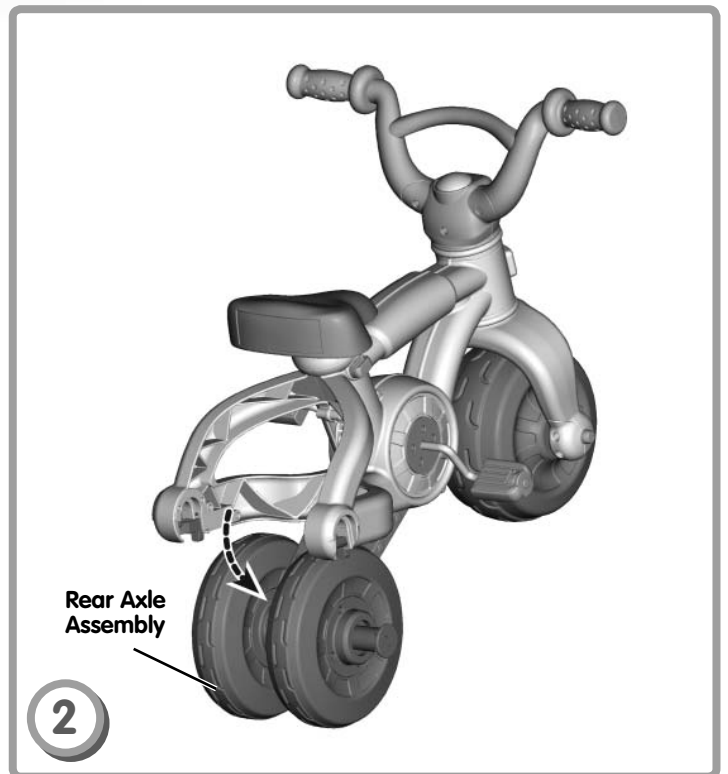

- Lower the rear axle assembly.

## Convert to Trike

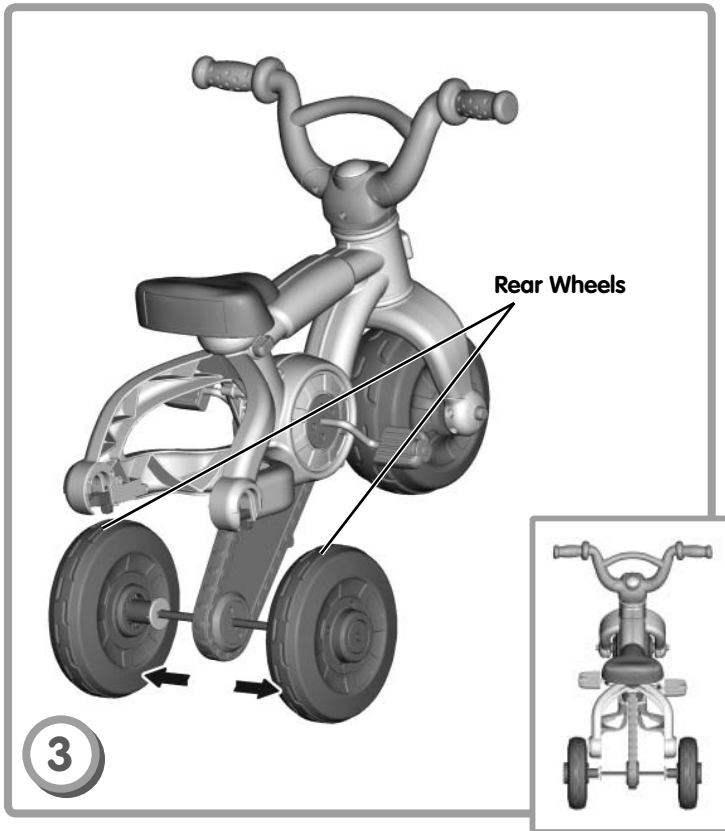

- Slide the rear wheels out.

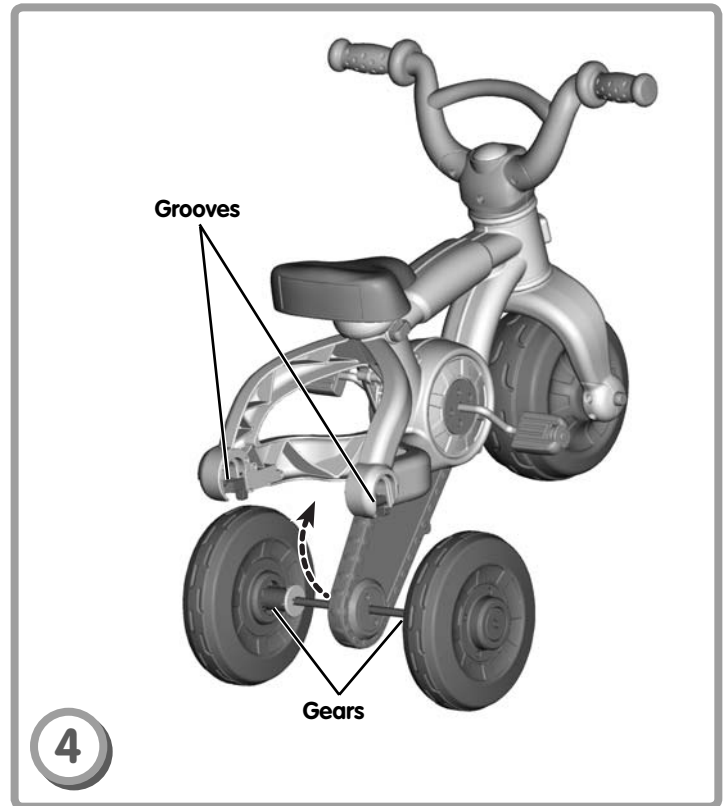

- Lift the rear wheels until the gears on the inside of the rear wheels **"snap"** into the grooves in the frame.
- Check to be sure the rear wheels are secure, by pulling down on them. If they are not secure, review these instructions carefully and try again.