

**TO PLAY (CONTO.) - PARA JUGAR (CONTINUACIÓN)
POUR JOUER (SUITE) - COMO BRINGAR (CONTINUAÇÃO)**

**RESCUE MODE (CONTO.) - MODO DE RESGATE (CONTINUACIÓN)
MODE SAUVETAGE (SUITE) - MODO RESGATE (CONTINUAÇÃO)**

7

Race through the "burning" path!
¡Acelera por el camino "en llamas"!
Traversez le circuit «enflammé»!
Corra pela pista "em chamas"!

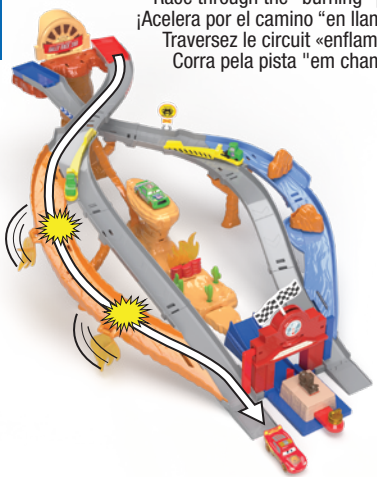

8

Pull back to lock the launcher.
Jala hacia atrás para bloquear el lanzador.
Tirez vers l'arrière pour enclencher le lanceur.
Empurre para trás para prender o lançador.

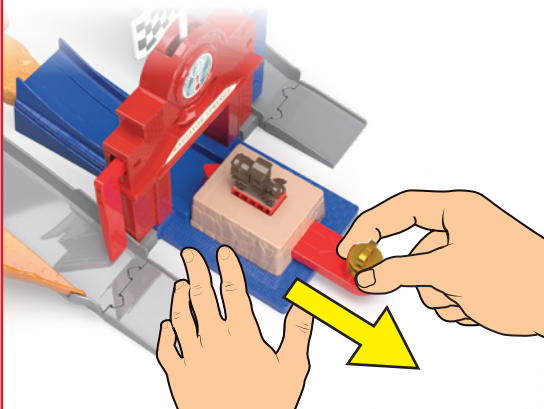

9

Load McQueen and press to launch!
¡Carga a 'McQueen' y presiona para lanzarlo!
Chargez Flash 'McQueen' et appuyez pour le lancer!
Coloque o 'McQueen' e aperte para lançar!

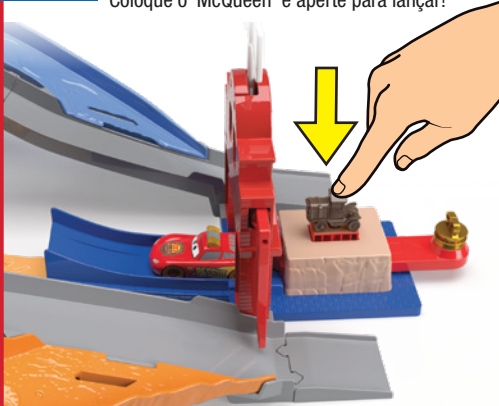

10

Put out the fire and knock down Chick!
¡Apaga el incendio y derriba a Chick!
Éteignez le feu et renversez Chick!
Incendeie e derrote Chick!

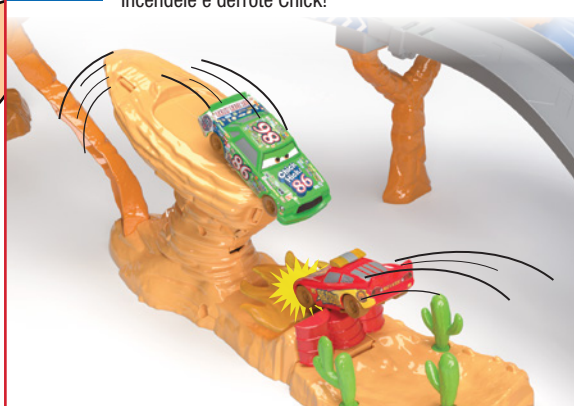

©2024 Mattel. ® and ™ designate U.S. trademarks of Mattel, except as noted. ® et ™ désignent des marques de Mattel aux États-Unis, sauf indication contraire. Mattel, Inc., 636 Girard Avenue, East Aurora, NY 14052, U.S.A. Consumer Services 1-800-524-8697. Mattel Canada Inc., Mississauga, Ontario L5R 3W2. You may call us free at / Composez sans frais le 1-800-524-8697. Mattel Europa B.V., Gondel 1, 1186 MJ Amstelveen, Nederland. Mattel U.K. Limited, The Porter Building, 1 Brunel Way, Slough SL1 1FQ, UK. Mattel Australia Pty. Ltd., 658 Church St., Richmond, Victoria, 3121. Consumer Advisory Service - 1300 135 312. Chinese mainland: Mattel Barbie (Shanghai), Trading Co., Ltd. Room 2005, 20th Floor, 899 Ruining Road, Xuhui District, Shanghai, 200232, PRC. Customer Care Line: 400-819-8658. Hong Kong SAR: Kids Kingdom Limited, Room 1908-9, Gala Place, 56 Dundas Street, Mongkok, Kowloon, Hong Kong, P.R.C. Customer Care Line: (852)2782-0766. Taiwan region: CHICKABIDDY CO., LTD, F5, No. 186, Sec. 4, Nanjing E. Rd., Taipei 10595, Taiwan region. Customer Care Line: 0800 001 256. Diimpor & Diedarkan Oleh: Mattel Continental Asia Sdn Bhd, Level 19, Tower 3, Avenue 7, No. 8 Jalan Kerinchi, Bangsar South, 59200 Kuala Lumpur, Malaysia. Mattel South Africa (PTY) LTD, Office 10213, 30 Melrose Boulevard, Johannesburg 2196. Importado y distribuido por Mattel de México, S.A. de C.V., Miguel de Cervantes Saavedra No. 193, Pisos 10 y 11, Col. Granada, Alcaldía Miguel Hidalgo, C.P. 11520, México, Ciudad de México. R.F.C. MME-920701-NB3. Tels.: 59-05-51-00 Ext. 5206 ó 01-800-463-59-89. Mattel Chile S.A., Pde. Riesco 5561, Of. 203-204 PS2, Las Condes, Santiago. Servicio al consumidor Venezuela: Tel.: 0-800-100-9123. Mattel Argentina, S.A., Av. Libertador 1000, Piso 11 – Oficinas 109 y 111, Vicente López – Prov. Buenos Aires. Tel.: 0800-666-3373. Mattel Colombia, S.A., Calle 123#7-07 P.5, Bogotá. Mattel Perú, S.A., Av. Juan de Arona # 151, Centro Empresarial Av. de Arona, Torre C, Piso 7, Oficina 704, San Isidro, Lima 27, Perú. RUC: 20425853865. Reg. Importador: 02350-12-JUE-DIGESA. Tel.: 0800-54744. E-mail Latinoamérica: Servicio.Clientes@Mattel.com. Distribuido por : Mattel do Brasil Ltda. - CNPJ : 54.558.002/0001-20 - Av. Dr. Chucri Zaidan, 296 -15º. Andar - 04583-110 - Vila Cordeiro - São Paulo - SP - Brasil. Serviço de Atendimento ao Consumidor: Contato: https://faleconosco.mattel.com.br/Contato. Email: sac.matteldobrazil@mattel.com.



JFL57-4B70
1103468397-4LB G1

**INSTRUCTIONS - INSTRUCCIONES
MODE D'EMPLOI - INSTRUÇÕES**



Please keep these instructions for future reference as they contain important information.
Guarda estas instrucciones para futura referencia, ya que contienen información importante.
Conservez ce mode d'emploi pour s'y référer en cas de besoin, car il contient des renseignements importants.
Guarde estas instruções para futura referência, pois contém informações importantes.

4+

CONTENTS - CONTENIDO - CONTENUTO - CONTEÚDO

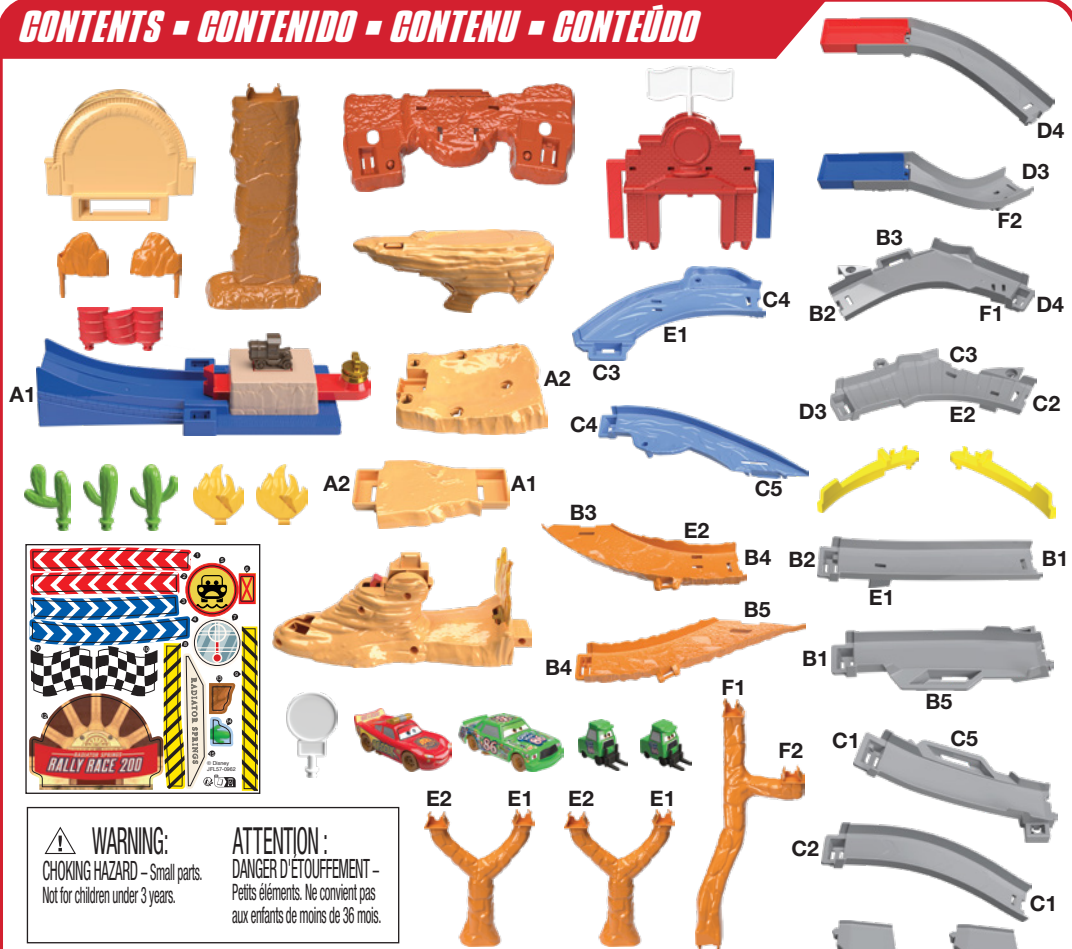

WARNING:
CHOKING HAZARD - Small parts.
Not for children under 3 years.

ATTENTION:
DANGER D'ÉTOUFFEMENT -
Petits éléments. Ne convient pas
aux enfants de moins de 36 mois.

WARNING: Not suitable for children under 36 months. Small parts.
ADVERTENCIA: PELIGRO DE ATRAGANTAMIENTO. Juguete no recomendado para menores de 3 años, porque contiene piezas pequeñas que podrían provocar asfixia en caso de ser ingeridas o inhaladas por el/la niño/a.

ATENÇÃO: NÃO INDICADO / NÃO RECOMENDÁVEL PARA CRIANÇAS MENORES DE 3 (TRÊS) ANOS POR CONTER PARTE(S) PEQUENA(S) QUE PODE(M) SER ENGOLIDA(S) OU ASPIRADA(S) PODENDO PROVOCAR ASFIXIA.

ATTENTION: NE CONVIENT PAS AUX ENFANTS DE MOINS DE 36 MOIS - PETITS ÉLÉMENTS.
Colors and decorations may vary. • Los colores y las decoraciones pueden variar. • Les couleurs et les motifs peuvent varier. • As cores e as decorações podem variar.

1 APPLY LABELS - PEGA LAS CALCOMANÍAS APPOSEZ LES AUTOCOLLANTS - COLAR ADESIVOS

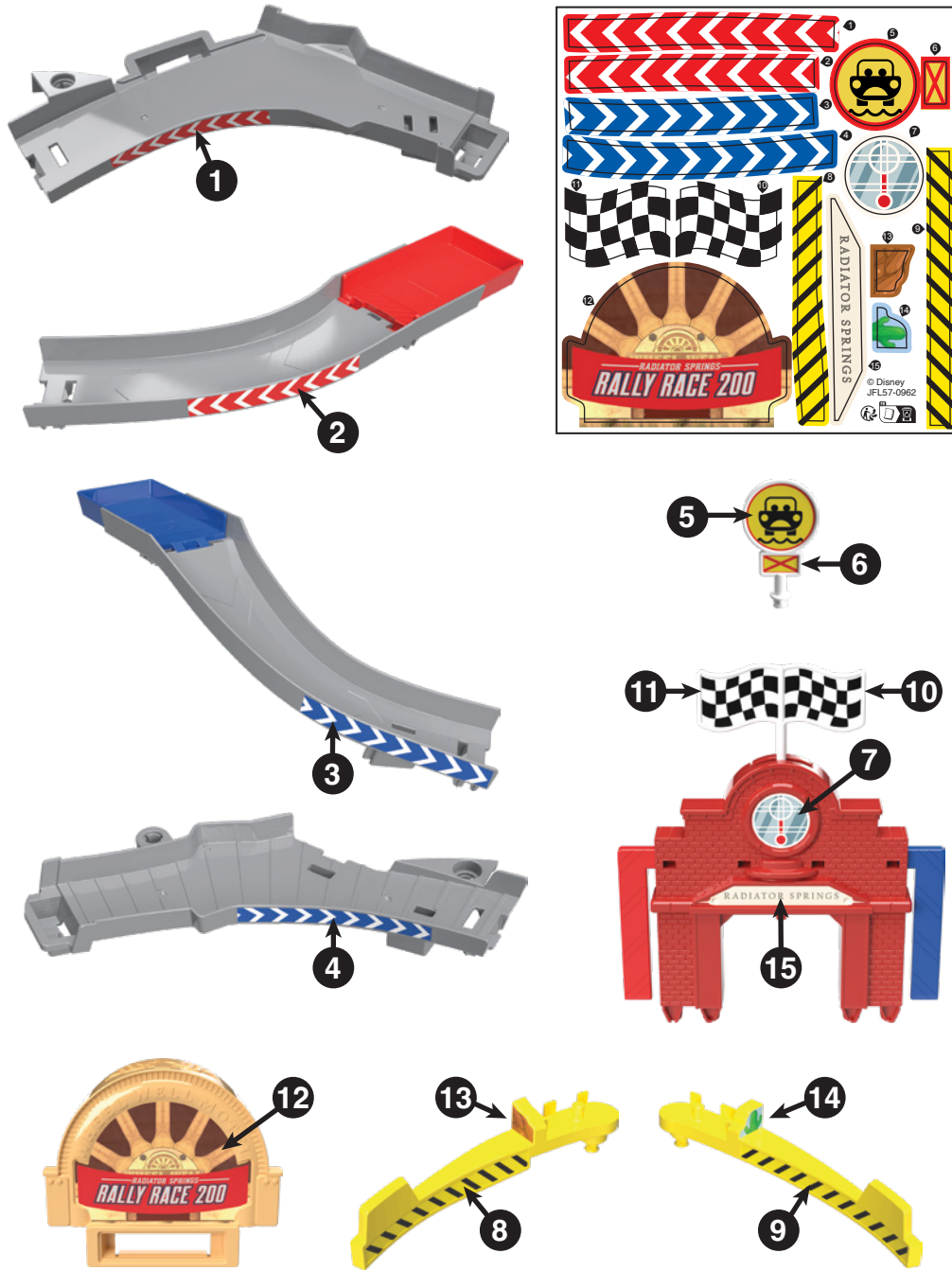

2 ASSEMBLY - MONTAJE - ASSEMBLAGE - MONTAGEM

1 Most of the parts are one-time snap assembly. • La mayoría de las partes se ensamblan sólo una vez.
L'assemblage est permanent pour la plupart des pièces. • A maioria das peças requer montagem uma única vez.

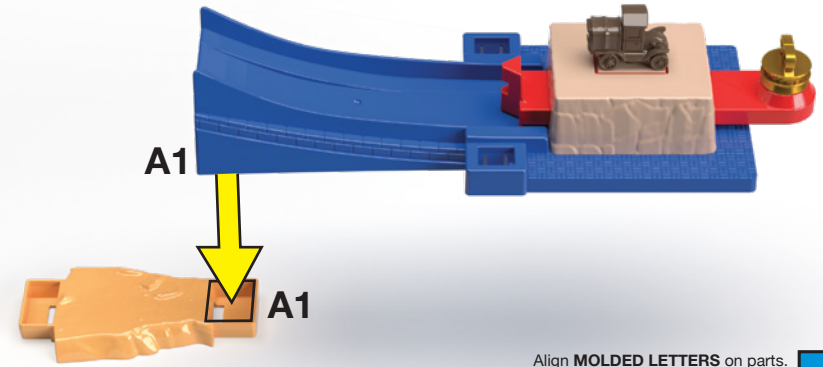

Align **MOLDED LETTERS** on parts.
Alinea las **LETRAS ESTAMPADAS** en las piezas.
Alignez les **LETTRES MOULÉES** indiquées sur les pièces.
Alinhe as **LETRAS MOLDADAS** nas peças.



2



3

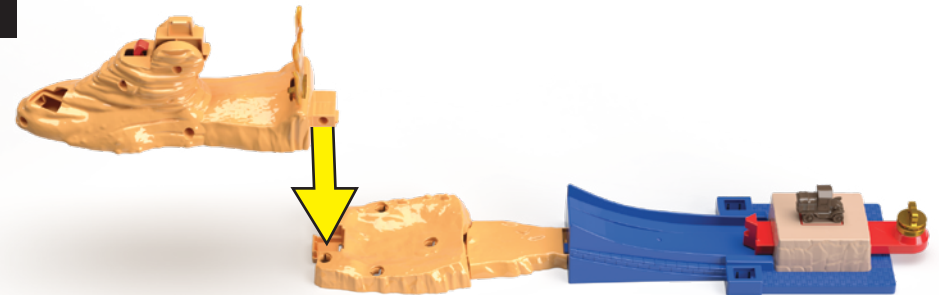

4



5

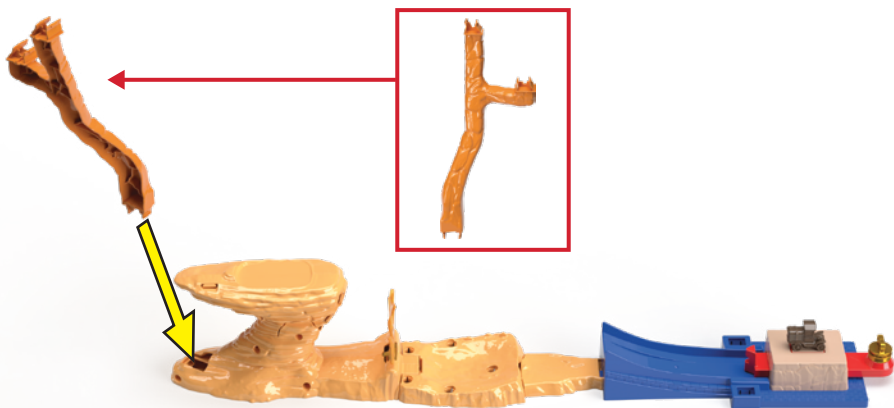

6

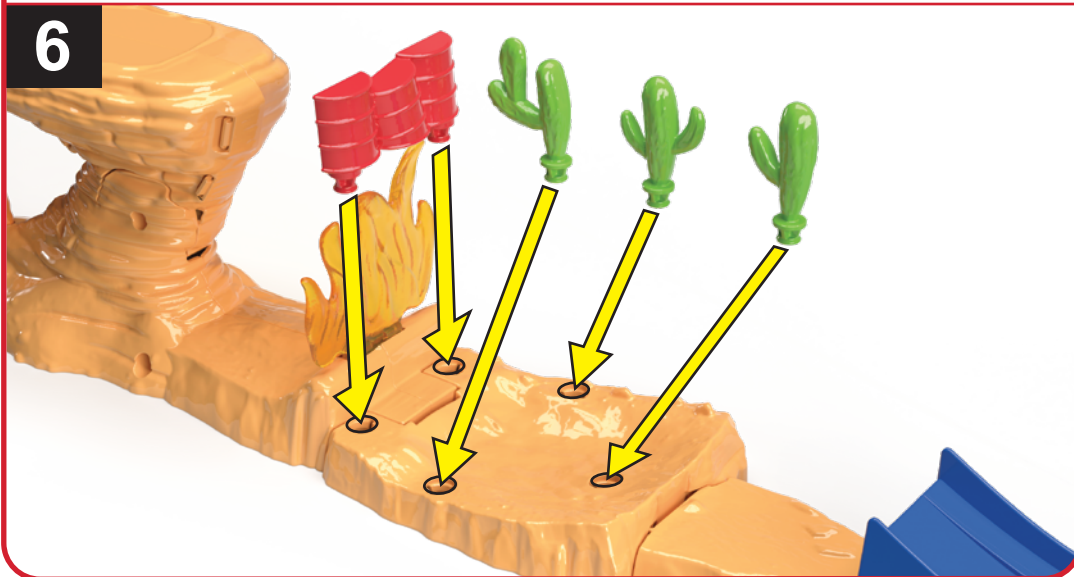

7

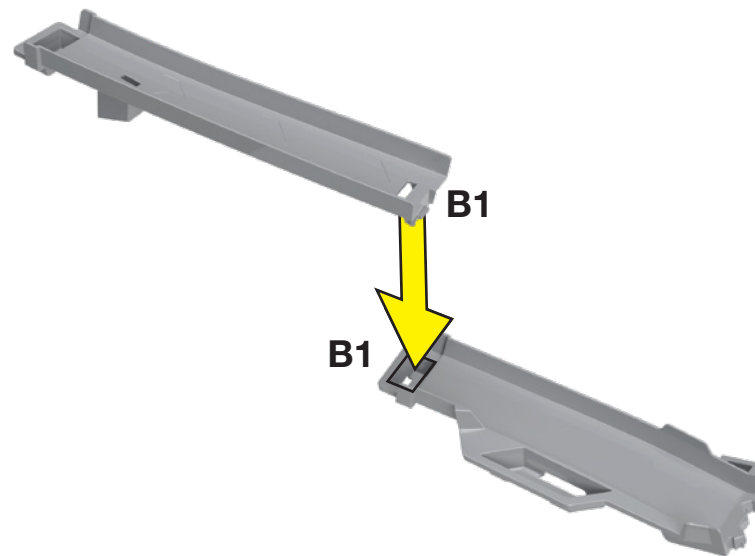

8

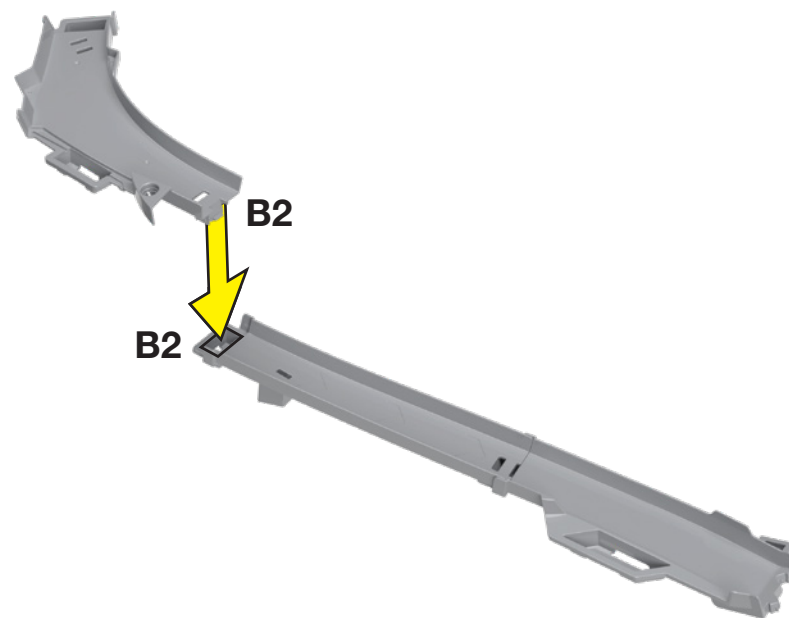

9

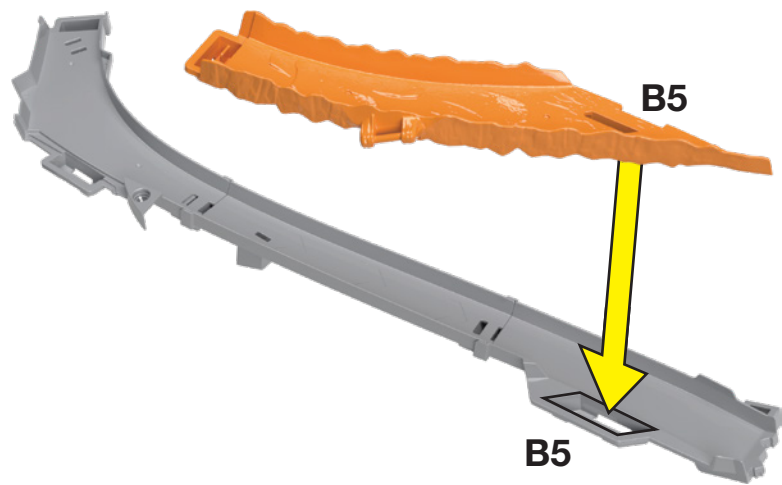

10

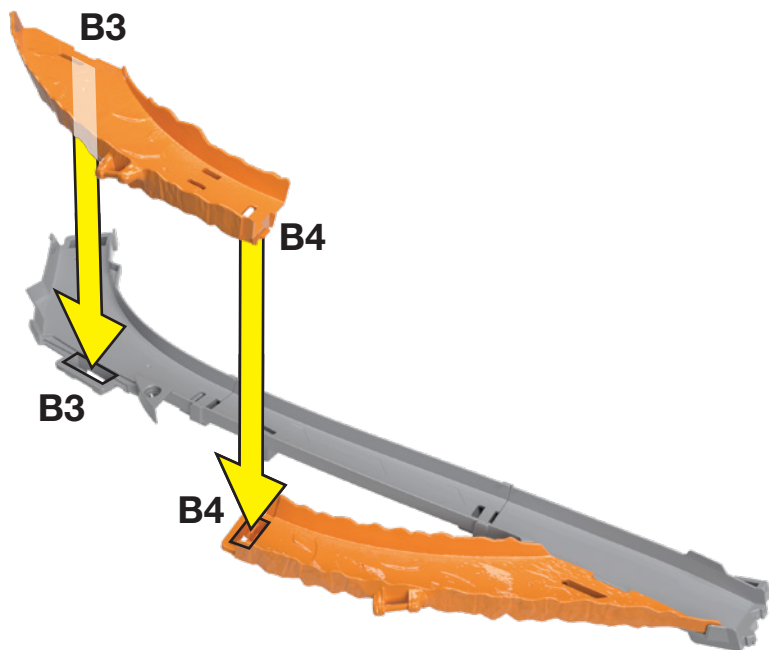

6

11

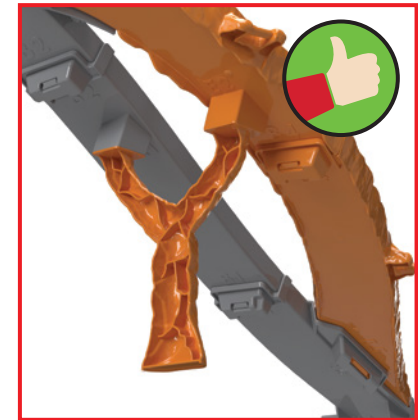
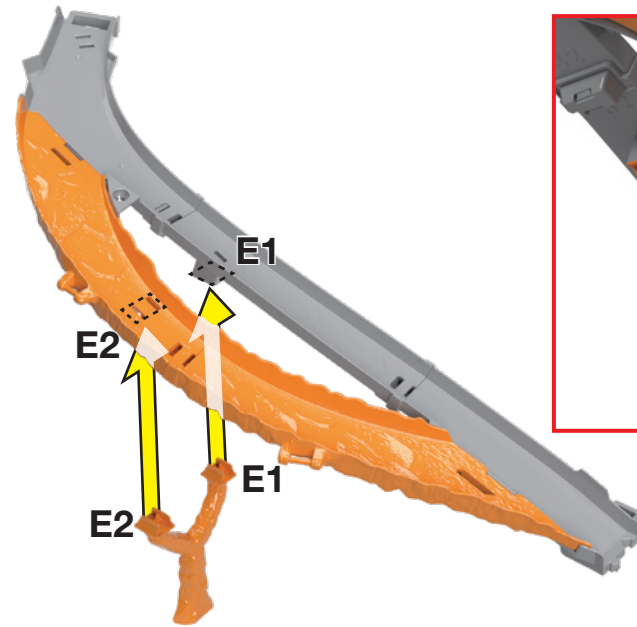

BOTTOM VIEW
PARTE INFERIOR
DESSOUS
BASE

12

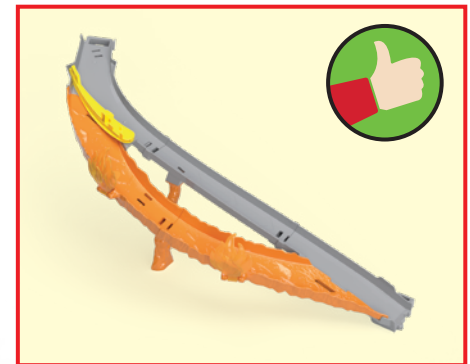
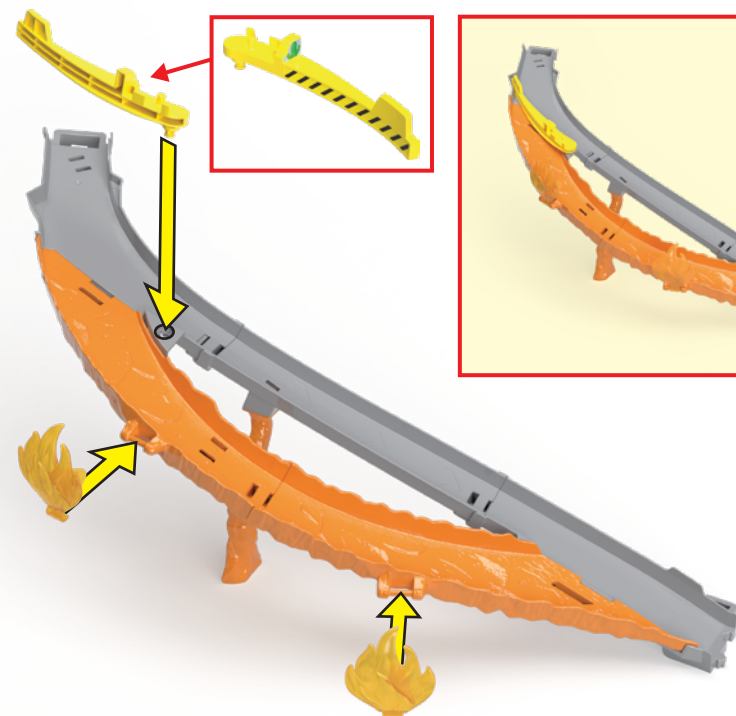

7

13

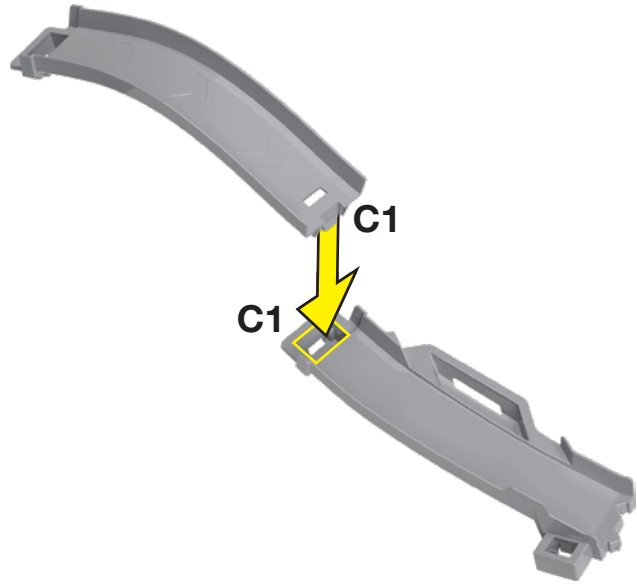

14

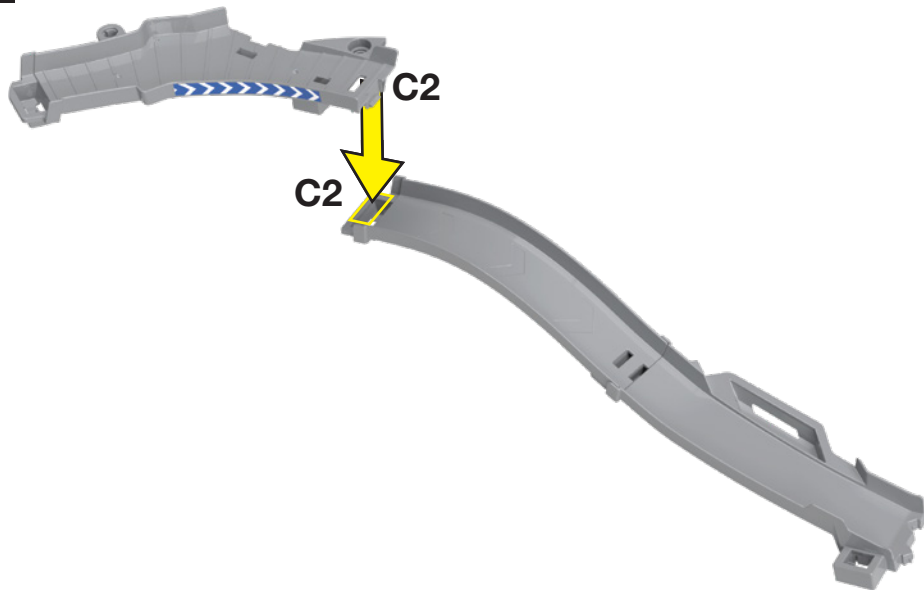

15

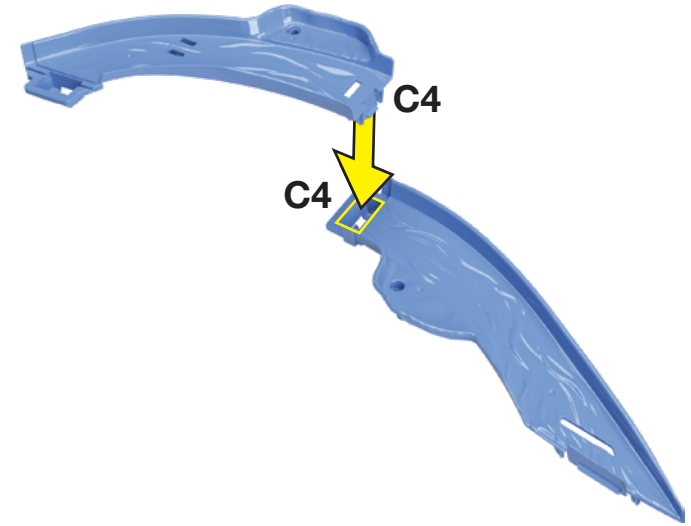

16

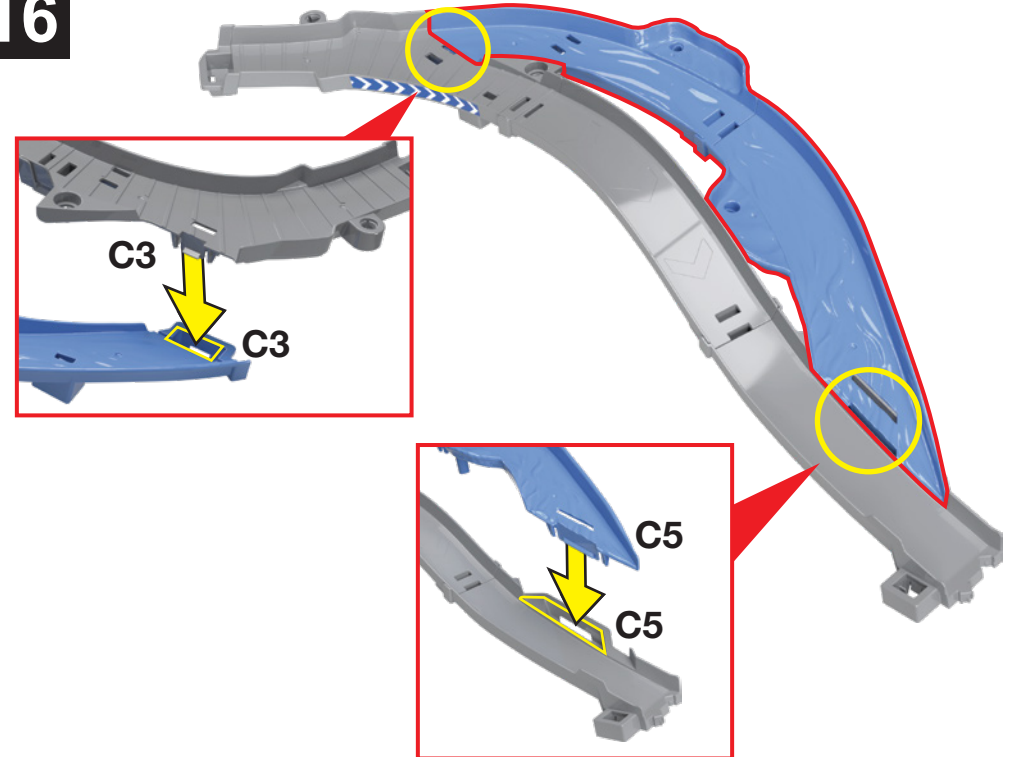

17

BOTTOM VIEW
PARTE INFERIOR
DESSOUS
BASE

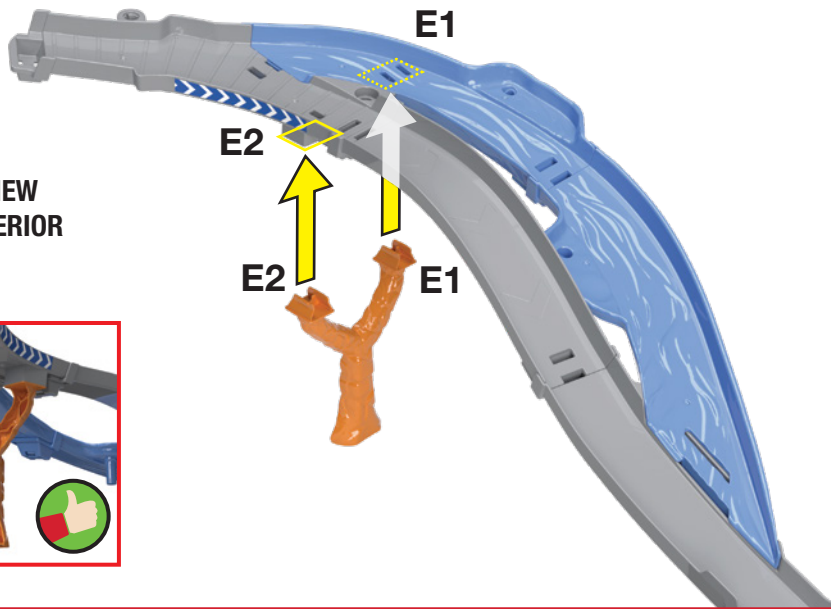
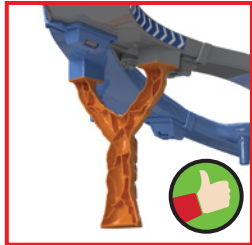

18

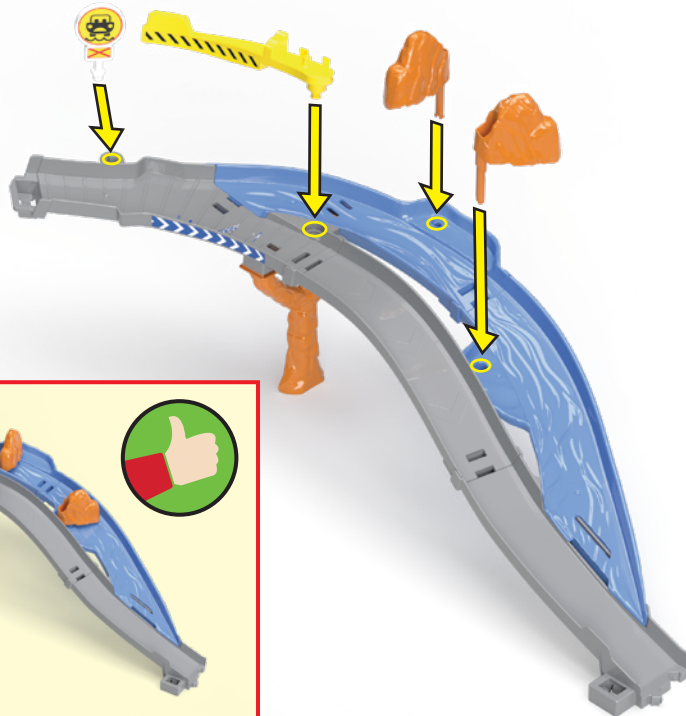
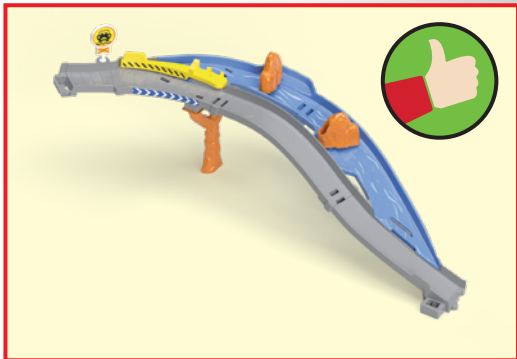

19

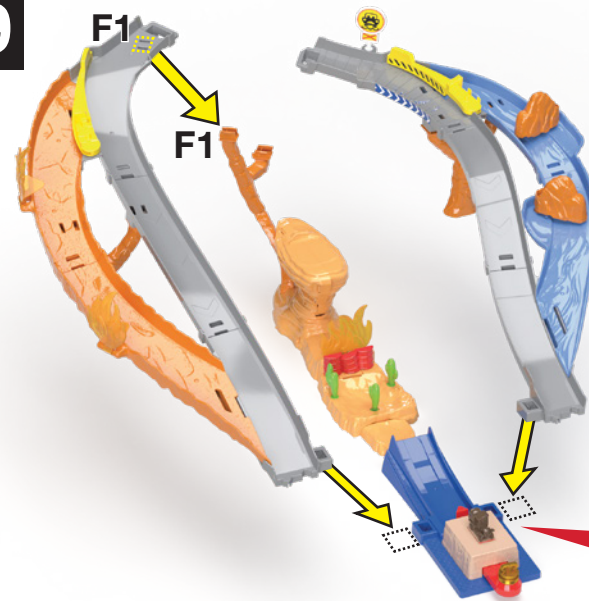

Align the slots.
Alinea las ranuras.
Alignez les fentes.
Alinhe as ranhuras.

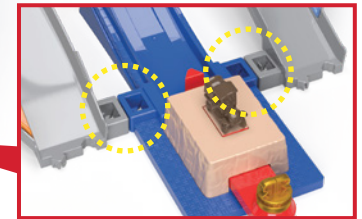

20

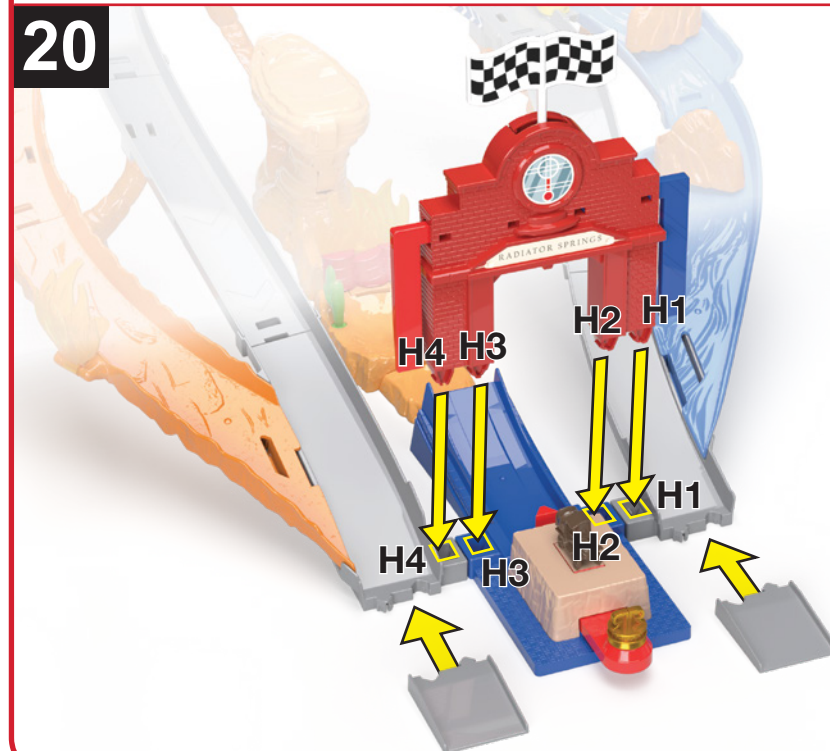

21



22



23

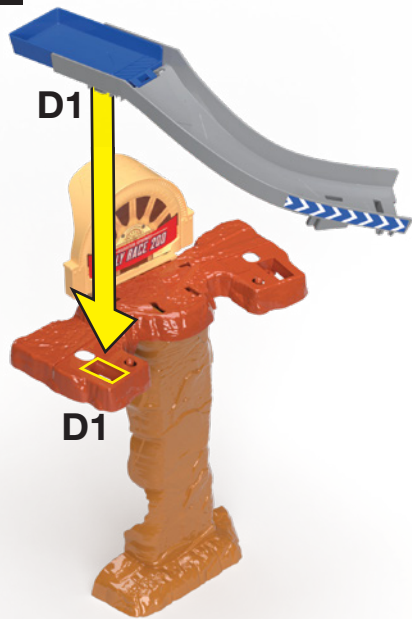

24

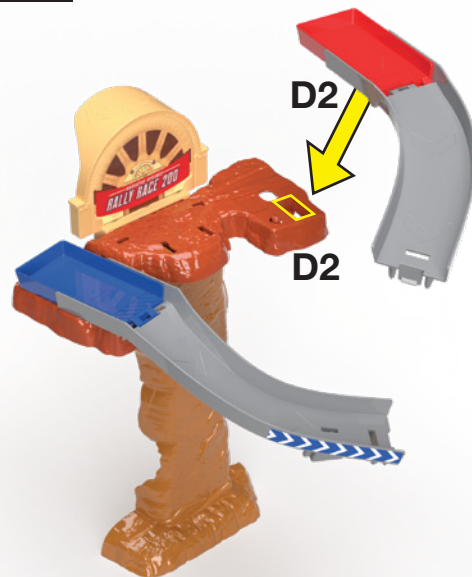

25

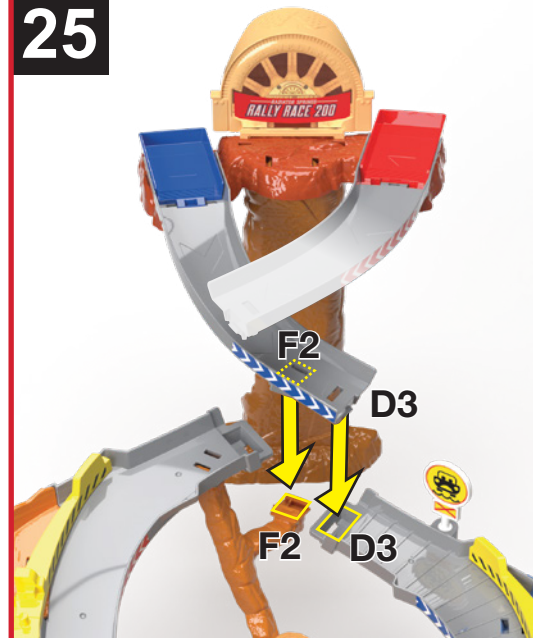

26

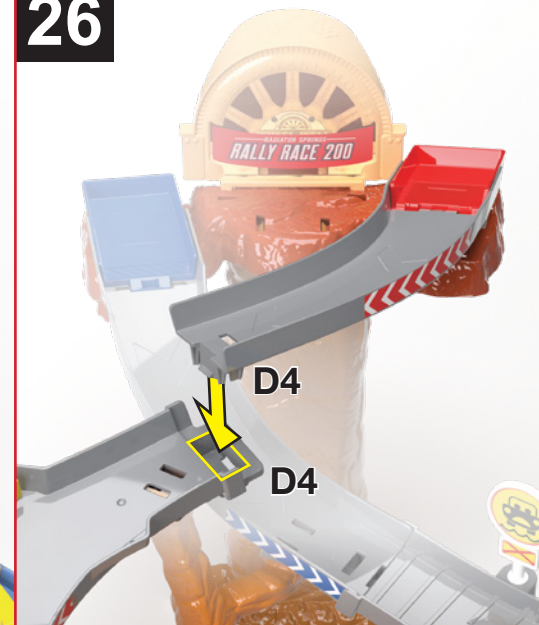

3 TO PLAY - PARA JUGAR - POUR JOUER - COMO BRINGAR

RACE MODE - MODO DE CARRERAS - MODE COURSE - MODO CORRIDA

1 Load vehicles on both sides.
Coloca los vehículos en ambos lados.
Chargez les véhicules des deux côtés.
Coloque os carros nos dois lados.



2 Set both diverters for a fair race.
Pon ambos mecanismos de desvío para que sea una carrera justa.
Réglez des deux déviateurs pour une course équitable.
Defina os dois desviadores para uma corrida justa.



3 Center the checkered flag for each race.
Centra la bandera a cuadros para cada carrera.
Centrez le drapeau à damier pour chaque course.
Centralize a bandeira quadriculada para cada corrida.



4 Press to launch the race!
¡Presiona para comenzar la carrera!
Appuyez pour lancer la course!
Aperte para começar a corrida!



5 Winner takes the checkered flag! • ¡El ganador se lleva la bandera a cuadros!
Le gagnant remporte le drapeau à damier! • O vencedor aciona a bandeira quadriculada!

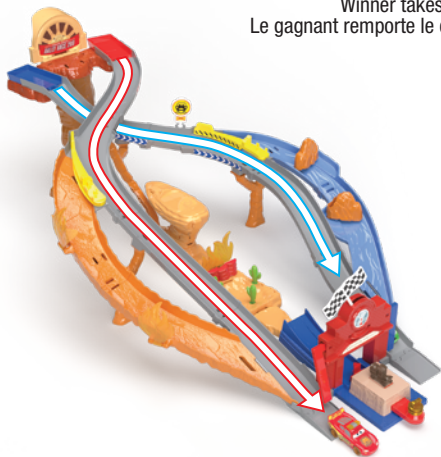

TO PLAY (CONTD.) - PARA JUGAR (CONTINUACIÓN) POUR JOUER (SUITE) - COMO BRINGAR (CONTINUAÇÃO)

RESCUE MODE - MODO DE RESCATE - MODE SAUVETAGE - MODO RESGATE

1 Reset the boulder. Load Chick and his pit crew.
Vuelve a colocar la roca. Carga a 'Chick' y su equipo de asistencia en pits.
Réenclenchez le rocher. Chargez 'Chick' et l'équipe de puits.
Redefina a pedra. Coloque 'Chick' e sua equipe.

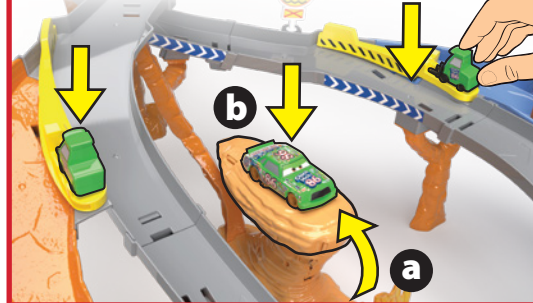

2 Set up the detours. • Prepara los desvíos.
Réglez les détours. • Monte os desvíos.

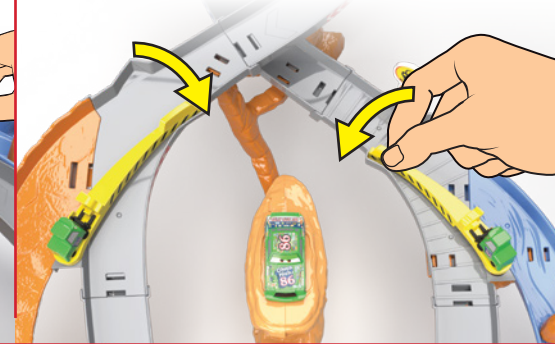

3 Reset the flames. • Vuelve a colocar las llamas.
Réenclenchez les flammes.
Redefina as chamas.



4 Launch on the BLUE side.
Lanza en el lado AZUL.
Lancez sur le côté BLEU.
Lance no lado AZUL.



5 Race through obstacles!
¡Pasa por los obstáculos!
Traversez les obstacles!
Corra pelos obstáculos!



6 Launch on the RED side.
Lanza en el lado ROJO.
Lancez sur le côté ROUGE.
Lance no lado VERMELHO.

