



HOT WHEELS



HONDA

Official Licensed Product
Produit Sous Licence Officielle



JFR88 - '07 HONDA S2000

'07 HONDA S2000

Launched in 1999 to celebrate the company's 50th anniversary, the S2000 is celebrated as one of the greatest cars Honda has ever produced. This front-engine open top roadster boasts an incredible 237 horsepower from its DOHC-VTEC engine. The 2007 model is distinguished by its reduced weight, making it ideal for the track. It has since cemented itself as a classic contemporary sports car.

Lancée en 1999 pour célébrer le 50^e anniversaire de la société, la S2000 est considérée comme l'une des plus grandes voitures que Honda ait jamais produites. Ce roadster décapotable avec moteur à l'avant est doté d'une puissance incroyable de 237 chevaux grâce à son moteur DOHC-VTEC. Le modèle 2007 se distingue par son poids réduit, ce qui le rend idéal pour la piste. Depuis, ce véhicule s'est imposé comme une voiture de sport à la fois classique et contemporaine.

1999

Honda launches the first S2000. The 'S' refers to 'sports' while the 2000 refers to the 2.0-litre I-4 engine. Later, they would produce more track-oriented models, such as this 2007 version.

Honda lance la première S2000. Le S veut dire « sport », tandis que « 2000 » fait référence au moteur I-4 de 2,0 litres. Par la suite, ils produiront des modèles plus destinés à la piste, comme cette version de 2007.

Honda lanza el primer S2000. La "S" hace referencia a "coche deportivo", mientras que el 2000 se refiere al motor I-4 de 2,0 litros. Más adelante se lanzaron modelos con un enfoque más enfocados al rendimiento en pista, como esta versión presentada en 2007.

Honda bringt den ersten S2000 auf den Markt. Das „S“ steht für „Sport“ und 2000 bezieht sich auf den 2-Liter-Vierzylindermotor. Später wurden mehr rennstreckenorientierte Modelle gebaut, wie diese Version aus dem Jahr 2007.



2011

Hot Wheels® releases their 1:64 scale S2000 die-cast in yellow, silver, and red. It was designer Ryu Asada's favorite JDM of all time.

Hot Wheels lance sa S2000 à l'échelle 1:64 en jaune, argent et rouge. C'était la JDM préférée du designer Ryu Asada.

Hot Wheels lanza el coche metálico del S2000 a escala 1:64 en amarillo, plata y rojo. Este modelo representa el coche japonés favorito de todos los tiempos del diseñador Ryu Asada.

Hot Wheels veröffentlicht das S2000 Die-Cast-Modell im Maßstab 1:64 in Gelb, Silber und Rot. Dies war das absolute Lieblings-JDM aller Zeiten des Designers Ryu Asada.



Lanzado en 1999 para conmemorar el 50.º aniversario de la marca, el S2000 está considerado uno de los mejores coches jamás fabricados por Honda. Este descapotable con motor delantero destaca por los impresionantes 237 caballos de su motor DOHC-VTEC. La versión de 2007 se caracteriza por un peso reducido, lo que lo convierte en una opción ideal para competir en la pista. Desde entonces, se ha consolidado como un clásico contemporáneo entre los deportivos japoneses.

Der Honda S2000 wurde 1999 anlässlich des 50 Firmenjubiläums auf den Markt gebracht und gilt als eines der besten Autos, die Honda je gebaut hat. Dieser Roadster mit Frontmotor begeistert mit unglaublichen 237 PS, die dank des DOHC-VTEC-Motors möglich gemacht werden. Das Modell aus dem Jahr 2007 zeichnet sich durch sein geringeres Gewicht aus, wodurch sich das Auto perfekt für die Rennstrecke eignet. Es hat sich seither als klassisches modernes Sportauto etabliert.

2025

With an authentically recreated spoiler, the brickified Honda S2000 is here and ready to hit the road.

Avec son aileron fidèlement restitué, la Honda S2000 en version brique est prête à prendre la route.

Ya está aquí el modelo de bloques de construcción del Honda S2000, con su alerón recreado hasta el más mínimo detalle y listo para salir a correr.

Die Baustein-Version des Honda S2000 mit authentisch nachgebaitem Spoiler ist bereit zur Abfahrt.





Get ready to race with the Hot Wheels Speed Series™. Each car in this series is built to tear up the racetrack and bolt to the finish line. The Hot Wheels Speed Series™ cars all include eye-catching decals and swappable wheel covers, so you can customize your ride just the way you want.

ON YOUR MARKS, GET SET, BUILD!

Préparez-vous à la course avec les Hot Wheels Speed Series™. Chaque voiture de cette série est conçue pour dominer la piste et foncer jusqu'à la ligne d'arrivée. Toutes les voitures Hot Wheels Speed Series™ ont des autocollants accrocheurs et des enjoliveurs interchangeables, ce qui vous permet de personnaliser votre véhicule à votre guise.

À VOS MARQUES, PRÊTS, CONSTRUISEZ !

Prepárate para la competencia con Hot Wheels Speed Series™. Cada coche de esta serie está diseñado para dominar la pista y alcanzar la meta a toda velocidad. Todos los coches de Hot Wheels incluyen pegatinas llamativas y tapacubos intercambiables, para que puedas personalizar tu vehículo a tu gusto.

¡PREPARADOS, LISTOS, A CONSTRUIR!

Entdecke die Welt der Hot Wheels Speed Series™. Jedes Auto in dieser Serie wurde dafür gebaut, die Rennstrecke zu erobern und mit voller Geschwindigkeit die Ziellinie zu überqueren. Im Lieferumfang der Speed Serie sind Sponsoren Aufkleber und austauschbare Radkappen enthalten, mit denen das Auto ganz nach eigenen Vorstellungen gestaltet werden kann.

AUF DIE PLÄTZE, FERTIG, BAUEN!



CUSTOMIZE YOUR CAR

PERSONNALISEZ VOTRE VOITURE

PERSONALIZA TU COCHE / DAS AUTO INDIVIDUELL GESTALTEN



76



Most models can be built one at a time. / La plupart des modèles peuvent être construits un à la fois. / Die meisten Modelle können eines nach dem anderen gebaut werden. / La maggior parte dei modelli possono essere realizzati uno per volta. / De meeste modellen kunnen één voor één gebouwd worden. / La mayoría de modelos se pueden construir de uno en uno. / A maioria dos modelos pode ser construída separadamente. / De fleste modeller kan byggas en i taget. / Useimmat mallit voidaan rakentaa yksi kerrallaan. / De fleste modeller kan bygges enkeltvis. / De fleste modellene kan bygges en om gangen. / Większości modeli nie da się budować jednocześnie z innymi. / Většinou lze najednou sestavit pouze jeden model. / Väčšina modelov môže byť zostavená iba raz. / A modellek többségéből egyszerre csak egy építhető. / Большинство моделей могут быть собраны по одной за раз. / Τα περισσότερα μοντέλα μπορούν να κατασκευασθούν ένα ένα. / Modellerin çoğu ayrı ayrı inşa edilmeyi gerektirebilir. / يمكن تركيب التصميم الواحد تلو الآخر.

THE MINDS **BEHIND THE WHEEL**

LES CONCEPTEURS **DERRIÈRE LE VOLANT**

LAS MENTES DETRÁS DEL VOLANTE / DIE KREATIVEN KÖPFE HINTER DEM KONZEPT



TRISTAN BRUNEAU

The S2000 is a JDM icon and everywhere in pop culture, so naturally we wanted to recreate it as a building set. This design balances authenticity from the real car and the extra Hot Wheels® cool factor, including a bigger spoiler and lowered roof. It has something to offer JDM fans, Hot Wheels® collectors, and building enthusiasts.

La S2000 est une icône des JDM et de la culture pop, c'est pourquoi nous voulions la recréer sous forme de set de construction. Ce design allie l'authenticité de la vraie voiture au charme de Hot Wheels, avec notamment

un aileron plus grand et un toit abaissé. C'est le modèle idéal pour les fans de JDM, les collectionneurs Hot Wheels et les passionnés de construction.

El S2000 es un ícono de la cultura popular tanto en Japón como en el resto del mundo, así que, obviamente, queríamos recrearlo como un conjunto de construcción. Este diseño respeta el equilibrio entre la autenticidad del coche real y el estilo de Hot Wheels, por ejemplo, al incluir un alerón más grande y un techo más bajo. Es un artículo imprescindible para los fans de los coches japoneses, los coleccionistas de Hot Wheels y los entusiastas de la construcción.

Der S2000 ist eine wahre Ikone und in der Popkultur stark verbreitet, weshalb wir ihn natürlich auch als Bauset entwickeln wollten. Dieses Design vereint die Authentizität des echten Autos mit dem besonderen Hot Wheels-Stil, einschließlich eines größeren Spoilers und eines niedrigeren Verdeckes. Fans japanischer Autos, Hot Wheels Sammler und Baufans werden begeistert sein.



JIMMY LIU

The S2000 is a neo-classic JDM car that has a cult-like following with car enthusiasts. It's one of the highest revving street cars ever built! For our version, we modified the aero on the car and created a custom aggressive body kit with a big wing and a hardtop. It's quickly become one of our iconic collector cars.

La S2000 est une voiture JDM néo-classique à laquelle les fans de voitures vouent un culte. C'est l'une des voitures les plus puissantes jamais construites ! Pour notre version, nous avons modifié l'aérodynamisme

de la voiture et créé une carrosserie personnalisée avec un grand aileron et un toit rigide. C'est rapidement devenu l'une de nos voitures de collection emblématiques.

El S2000 es todo un clásico moderno de la automoción japonesa y, con el tiempo, se ha transformado en un objeto de culto para los amantes del motor. ¡Es uno de los urbanos más veloces jamás fabricados! Para crear nuestra versión, rediseñamos su aerodinámica y desarrollamos una carrocería personalizada y dinámica, equipada con un gran alerón y un techo rígido. Rápidamente se ha convertido en uno de los coches más emblemáticos de nuestra colección.

Der S2000 ist ein neoklassisches japanisches Auto, das eine riesige Fangemeinde hat. Es ist eines der hochtourigsten Autos, das je gebaut wurde. In unserer Version haben wir die Aerodynamik etwas verändert und eine individuelle Karosserie mit großem Kotflügel und Hardtop entwickelt. Dieses Modell hat sich schnell zu einem unserer legendären Sammlerautos entwickelt.





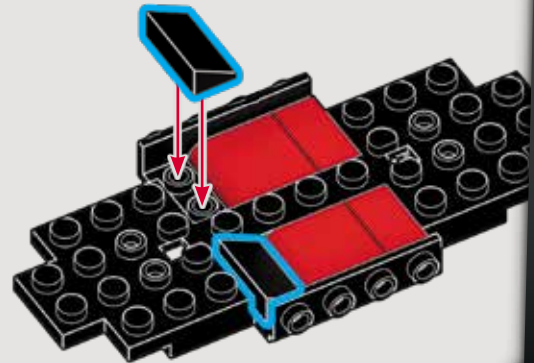
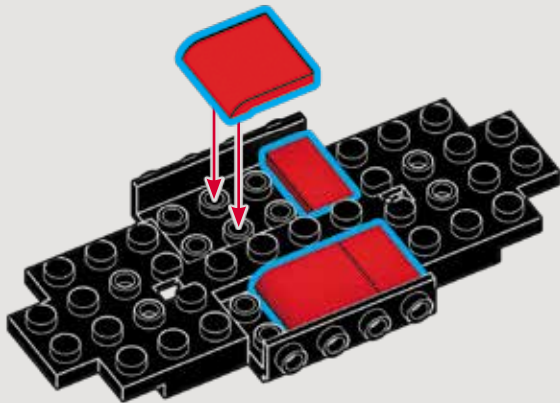
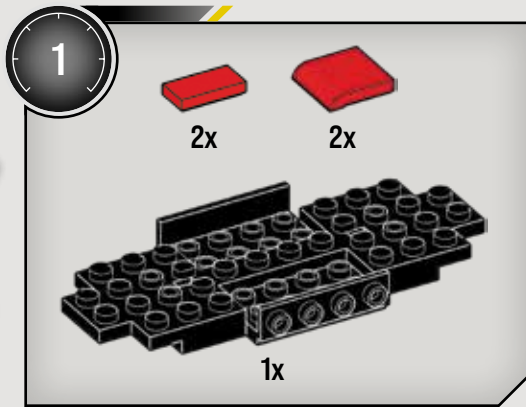

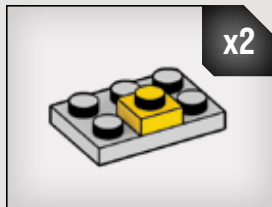
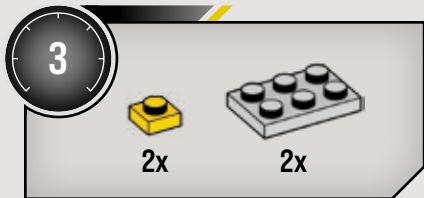

1



2

4



1x

1x



1x

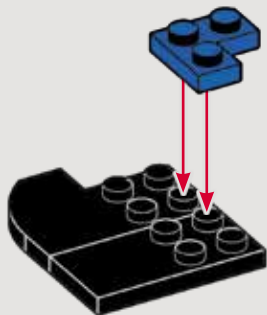

5



1x

1x

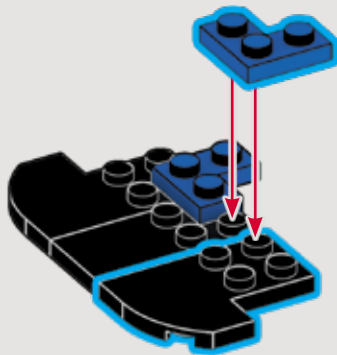

6

2x6



1x

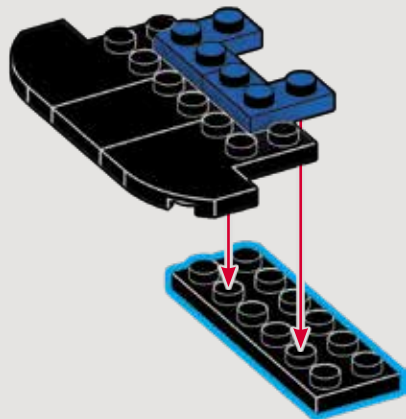

1

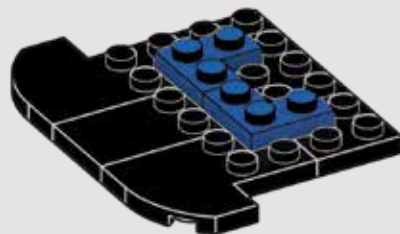

2

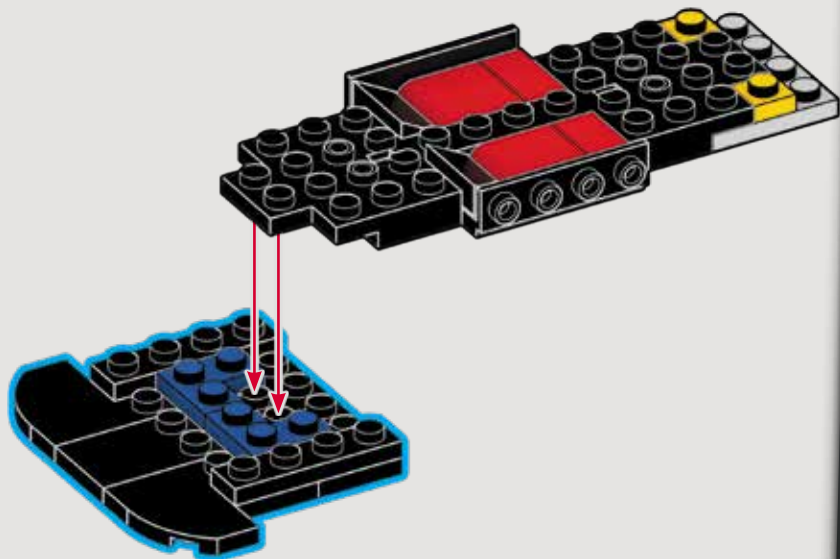
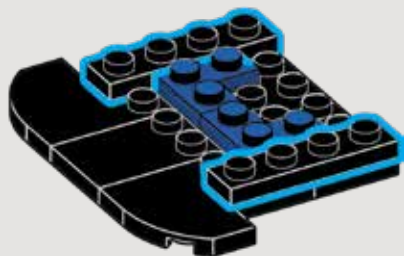
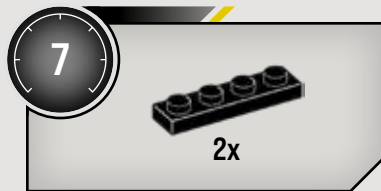

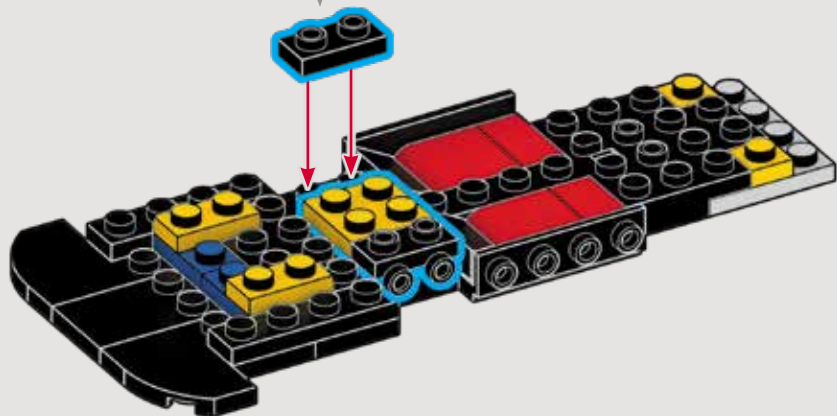
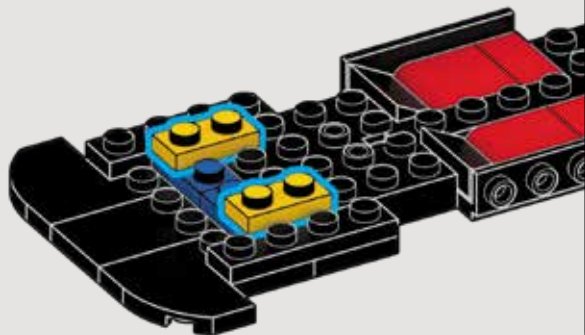

11



1x



2x

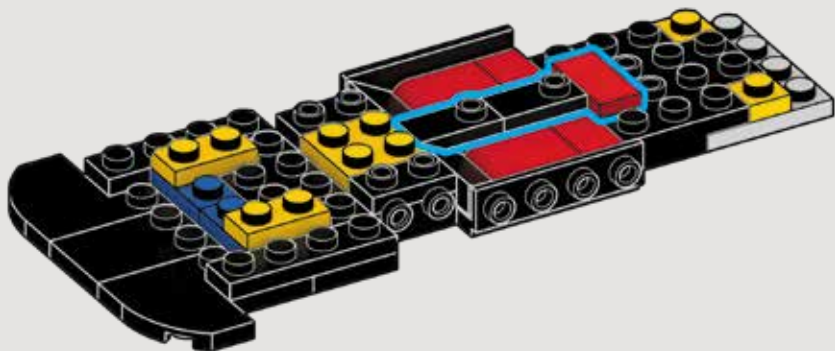

12



2x



1x

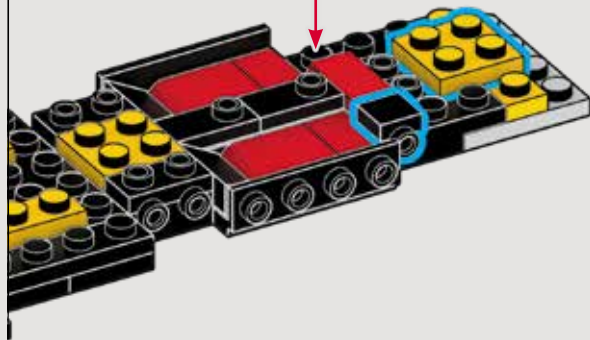

13



2x



2x



x2



1



2

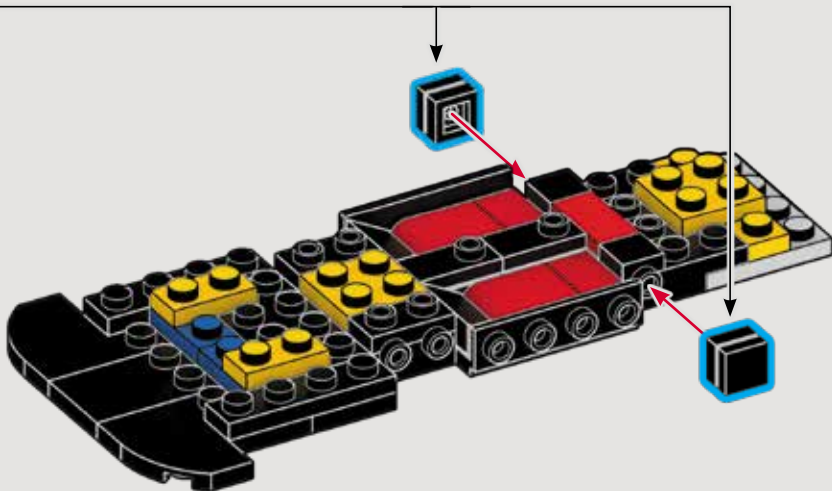

14



2x



1x



1x



1

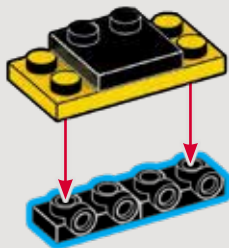

2



3

15

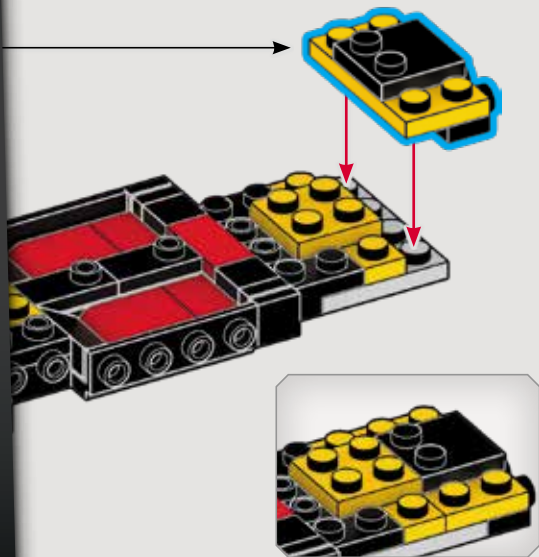

16



2x



2x

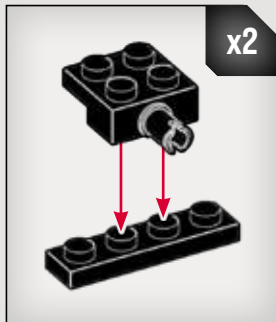

x2

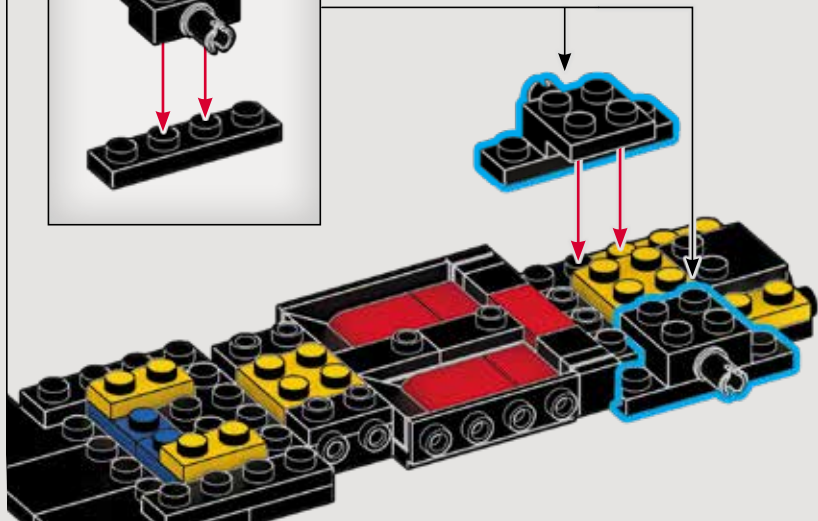

17



2x



1x

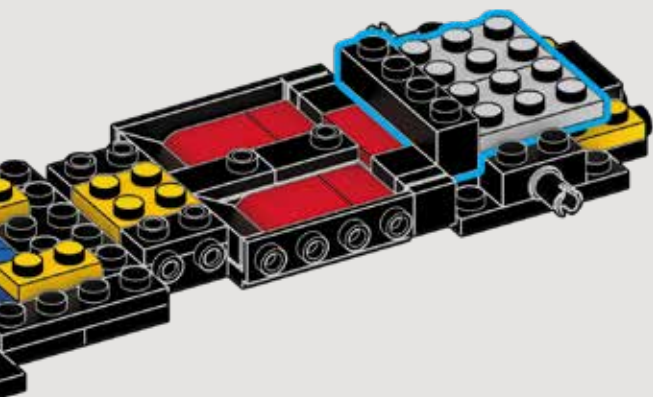

18



2x

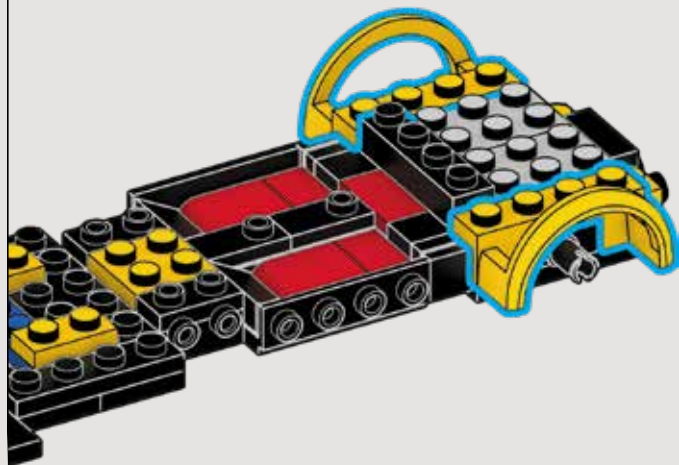

19



1x



2x



2x

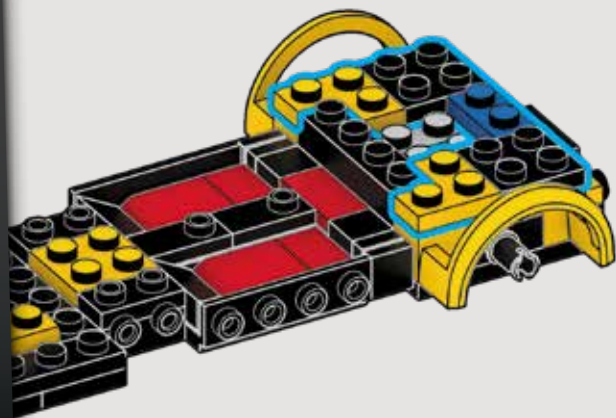

20



1x



1x

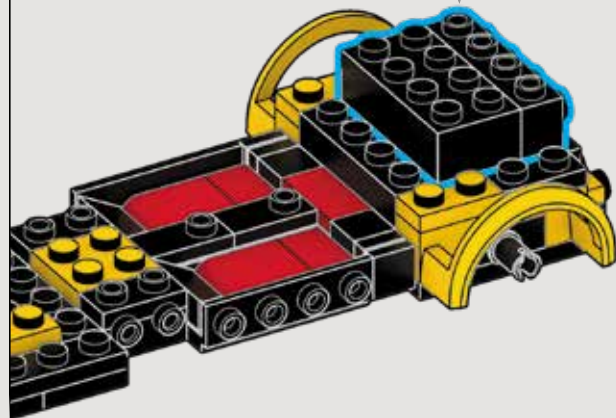

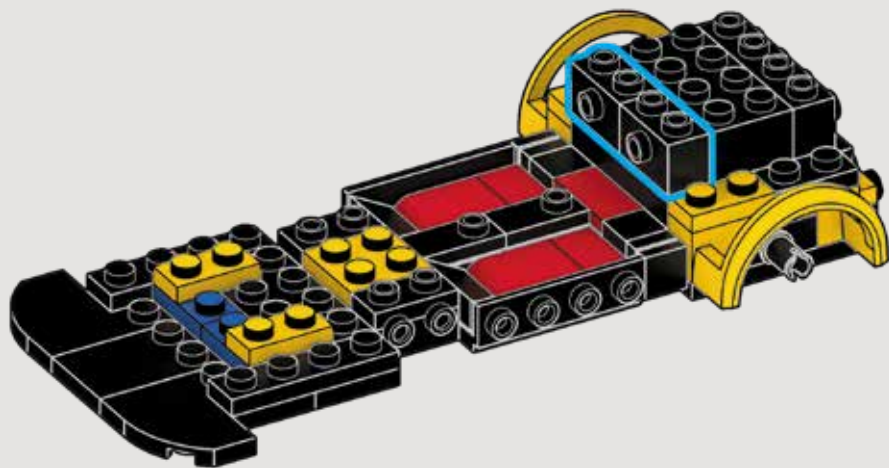

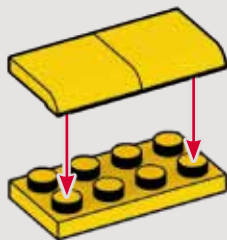
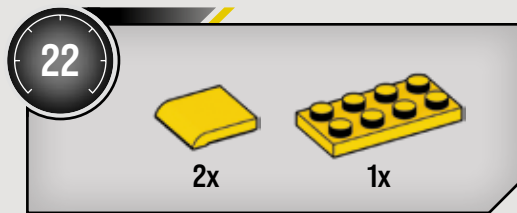
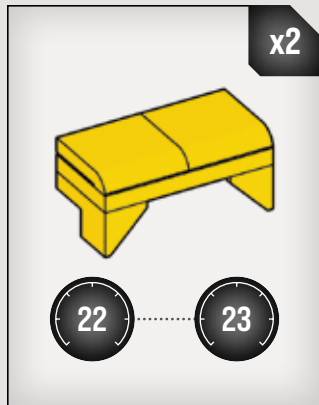

23



1x



1x



1x

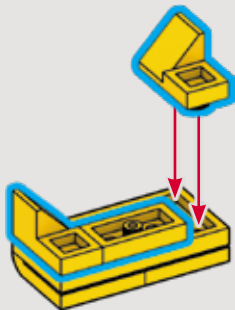

1

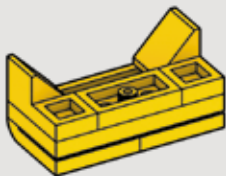

2

24

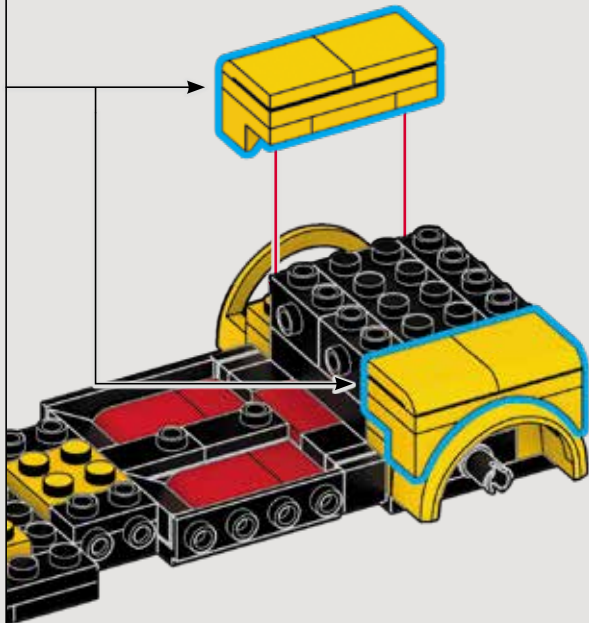

25



1x



1x

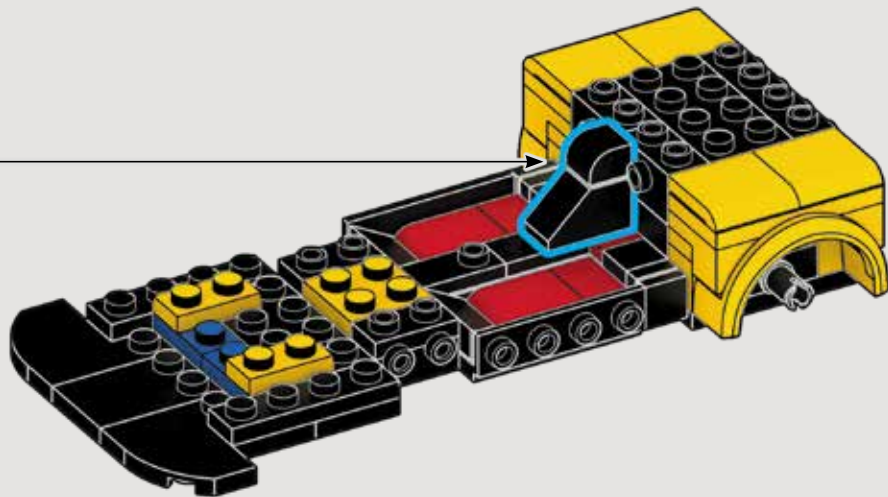

26



3x



2x



1x

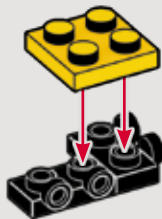

1

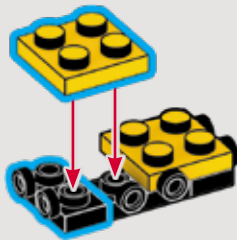

2



3

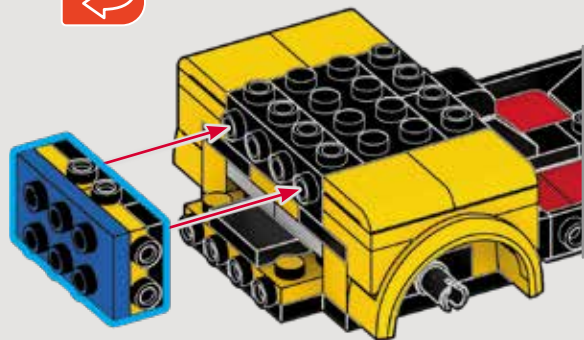

1

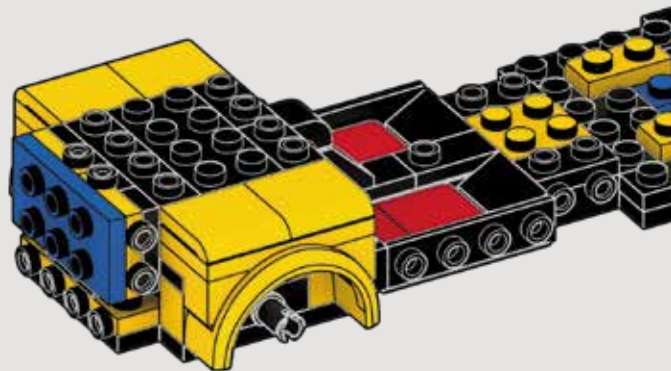

2

28



2x

1x6



1x

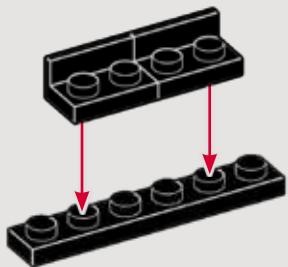

29



2x

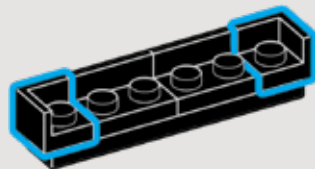

30



2x



2x

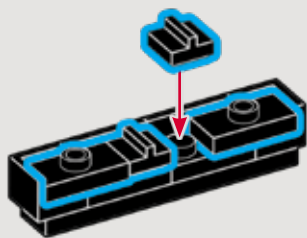

31



2x

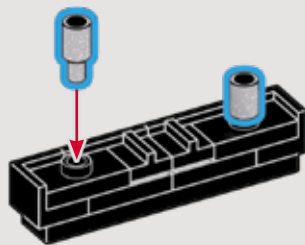

1

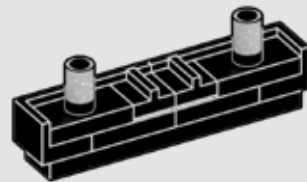

2

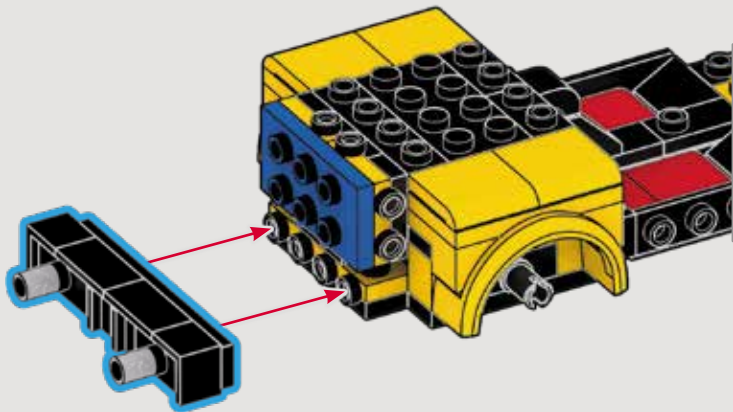

1

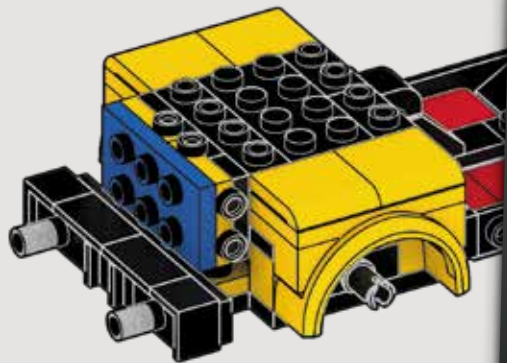

2

33



2x



2x



2x



2x



2x



2x

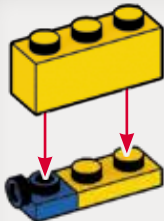

1

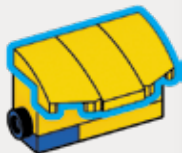

2



1

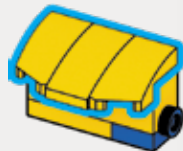

2

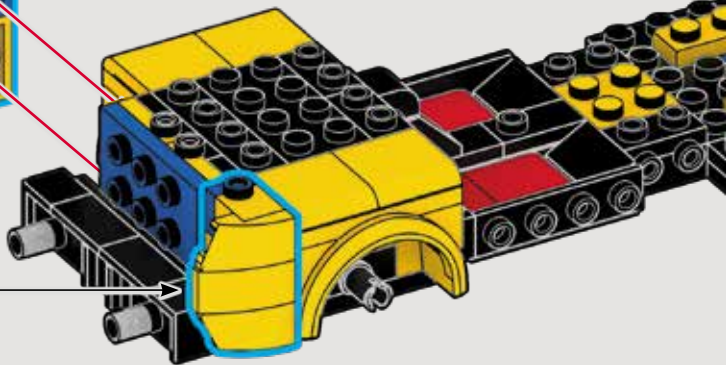

34



2x



1x



1x



1x

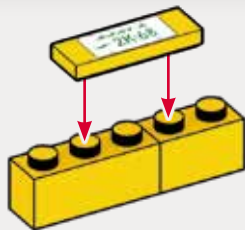

1

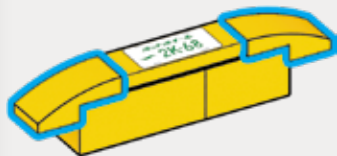

2

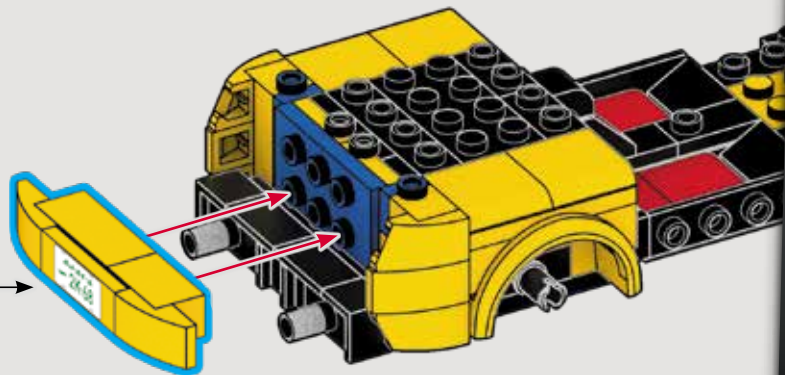

35



1x



1x

1x5



1x

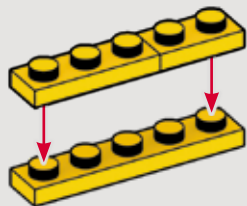

36



1x

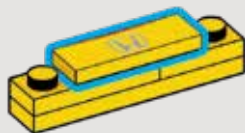

37



1x



1x

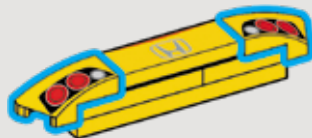



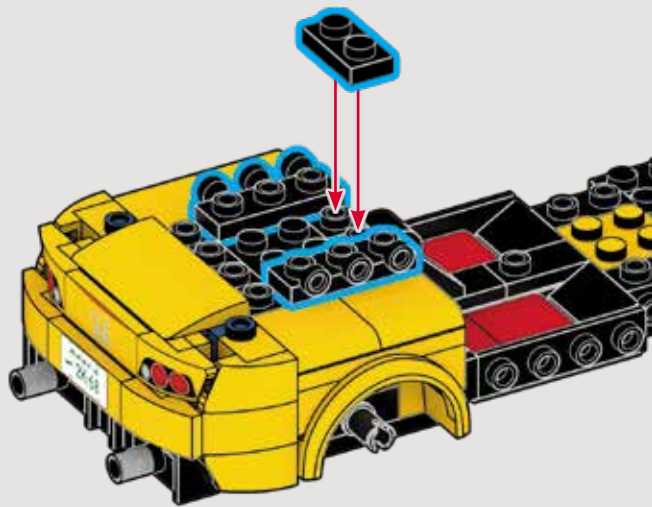
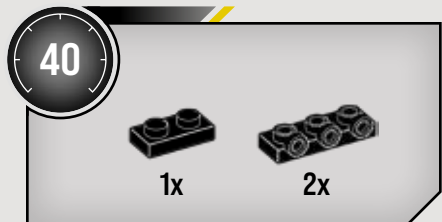
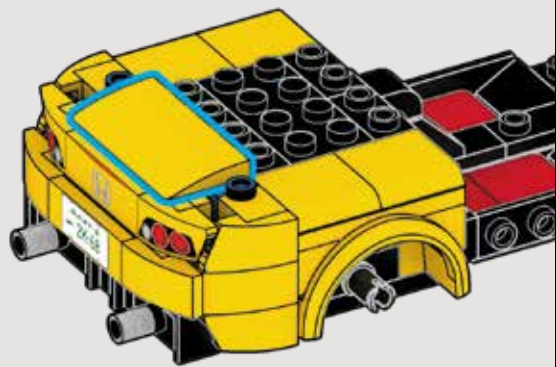
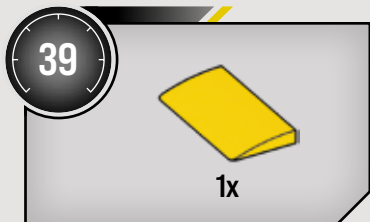

41



2x



1x

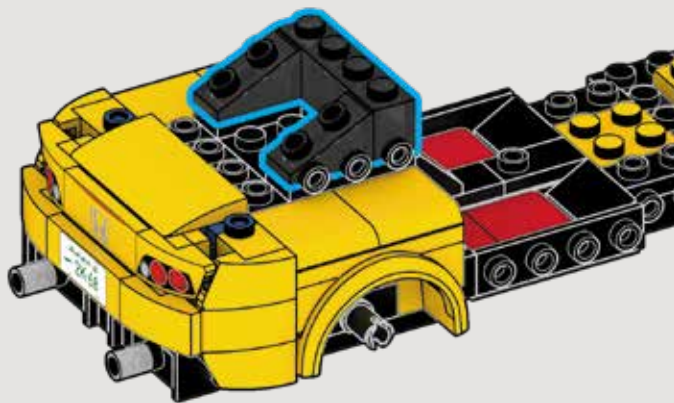

42

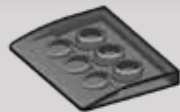

1x

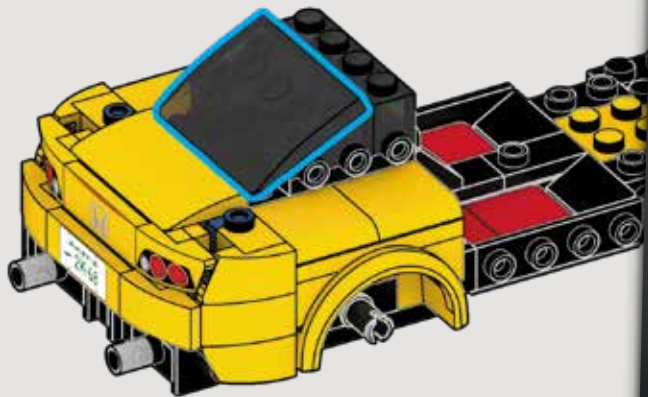

43



2x



2x

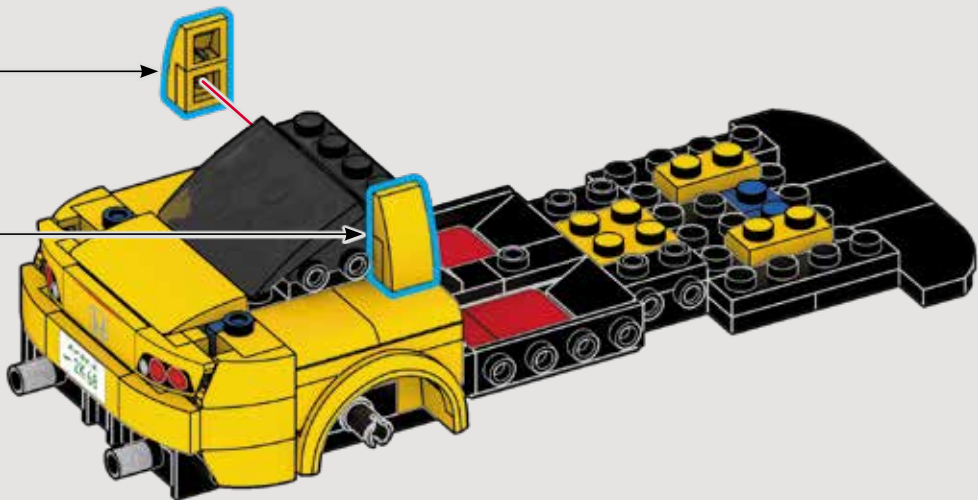
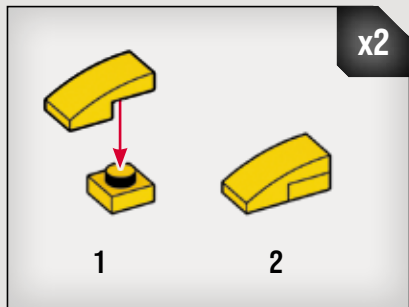

44



1x



1x

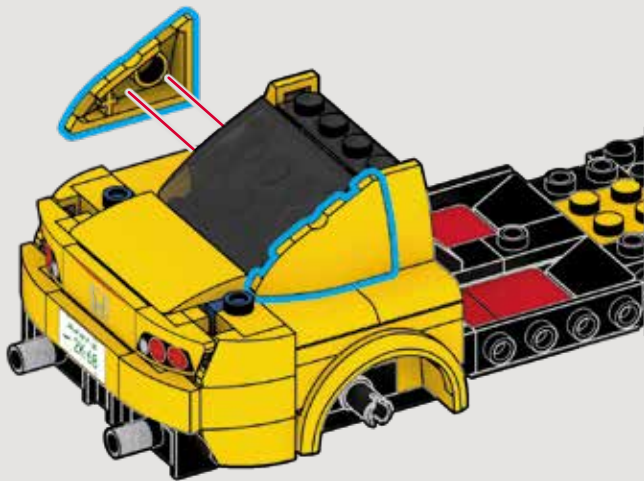

1

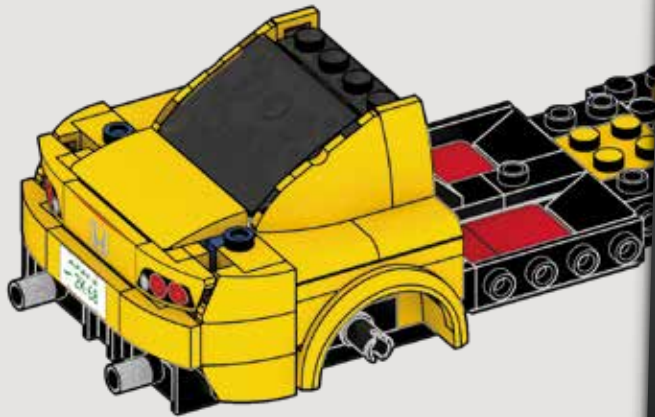

2

45



1x



1x



1x

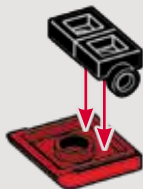

46



1x



47



1x

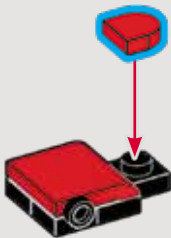

48



1x



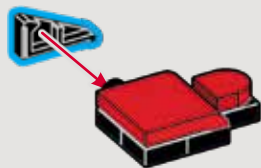
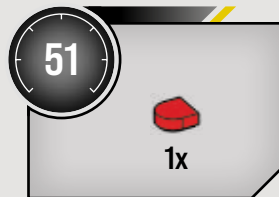
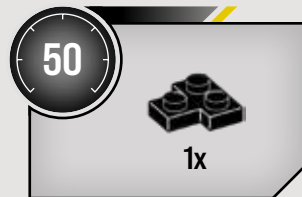
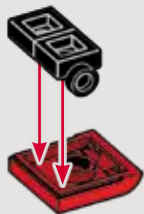

1



2

53

52

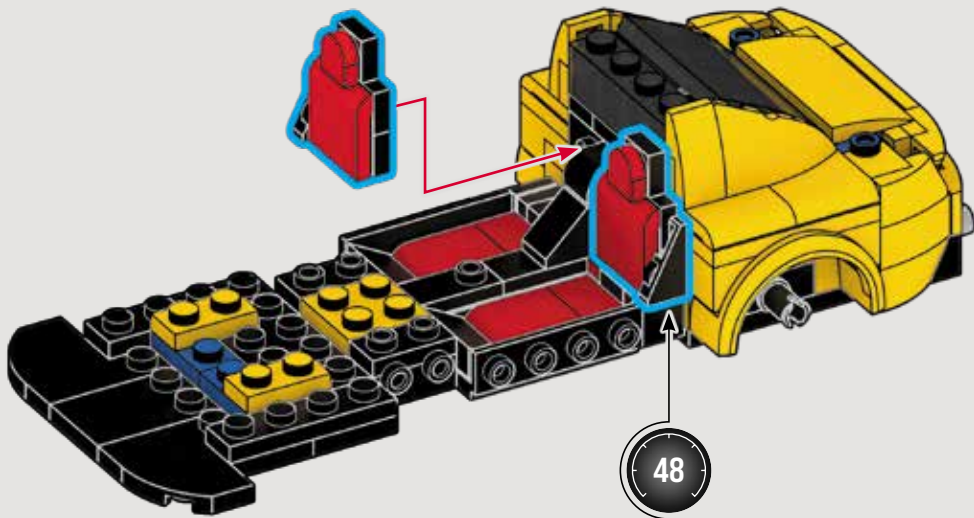

48

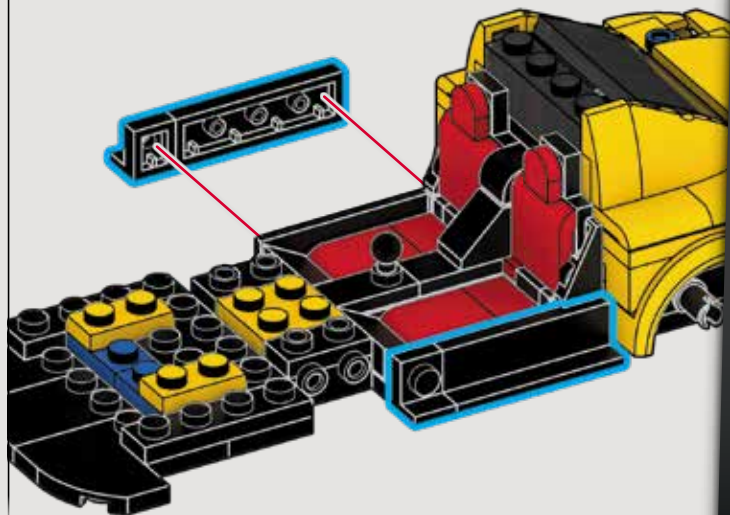
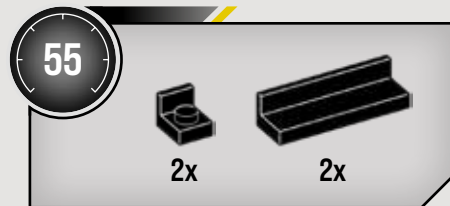
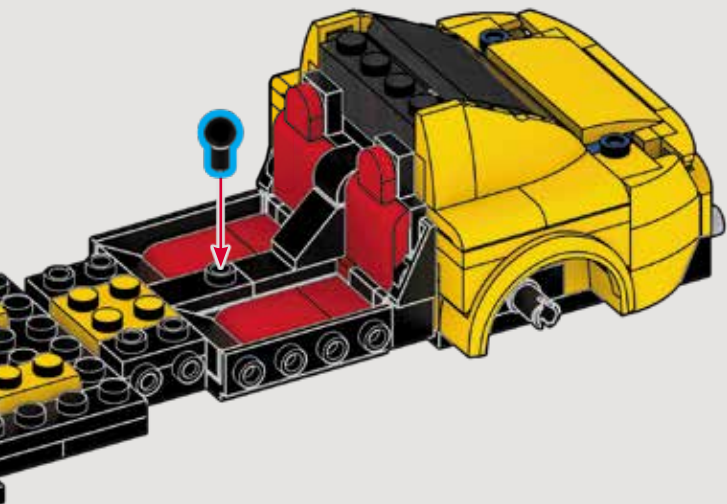
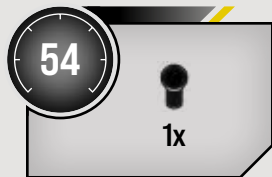

56



1x



1x



1x

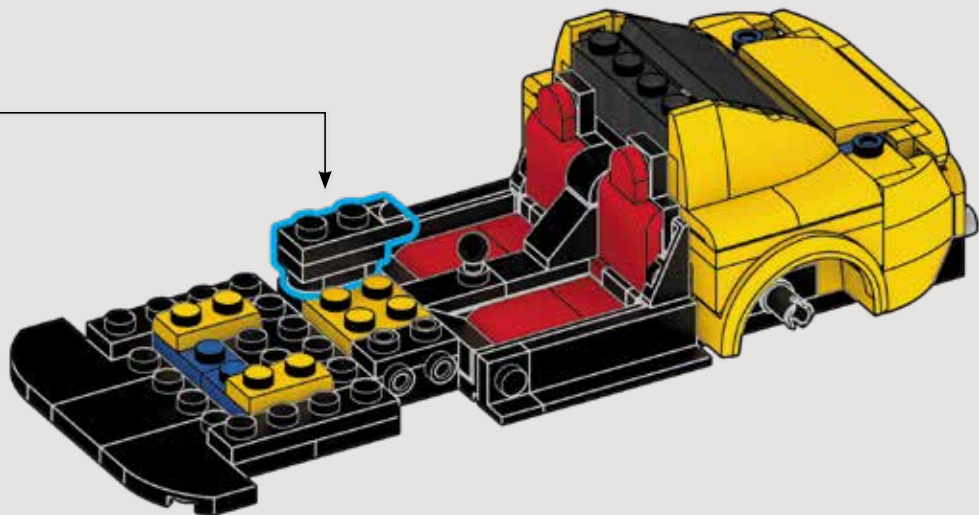
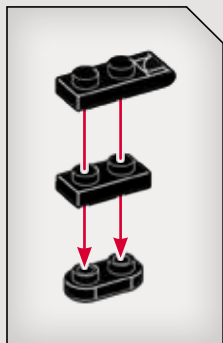

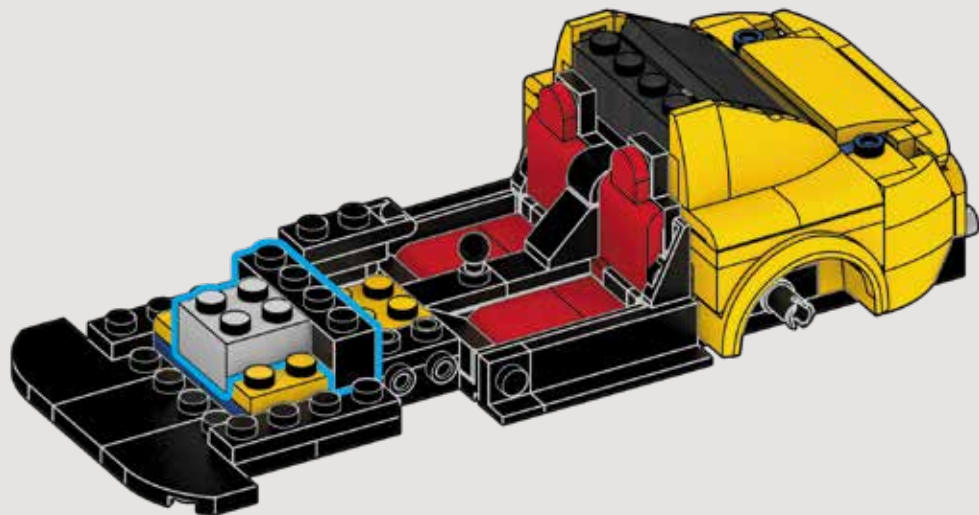
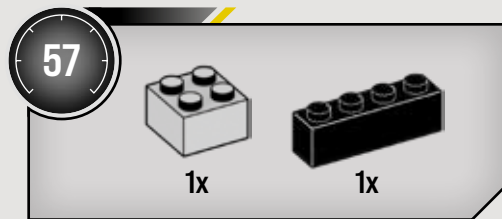

58



2x



1x

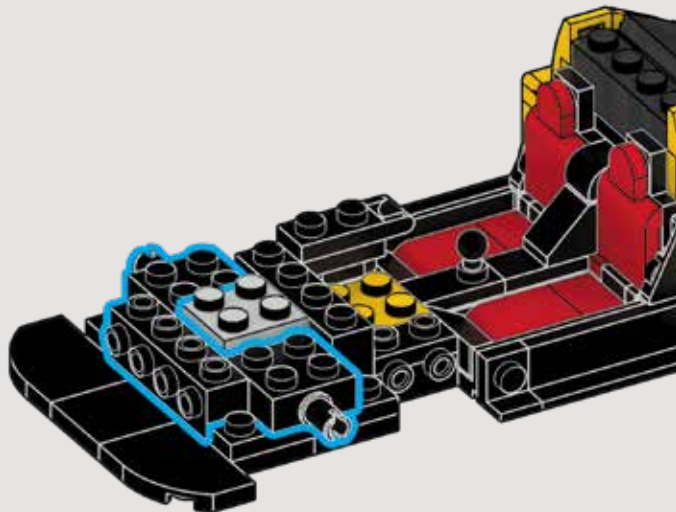

59



1x

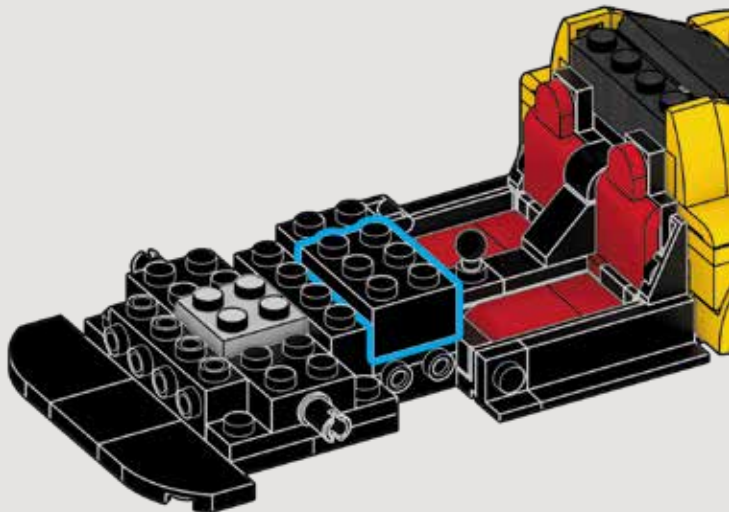

60



2x

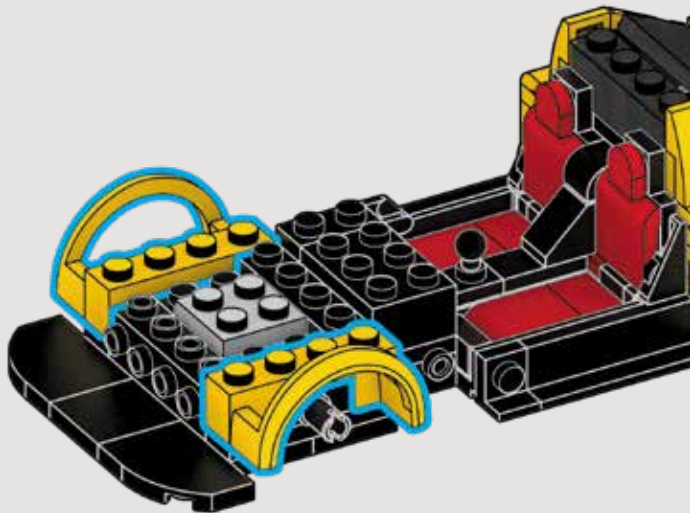

61



2x

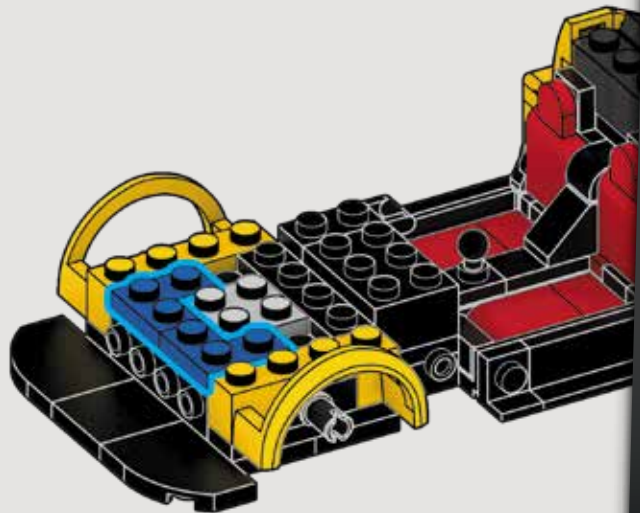

62



3x

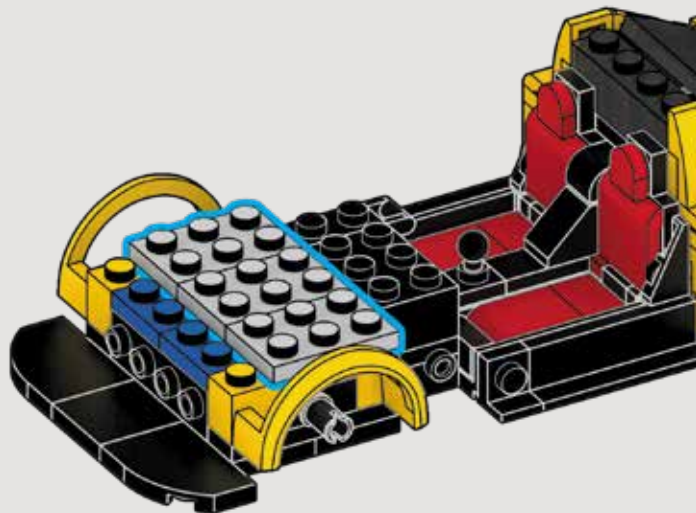

63



2x



2x

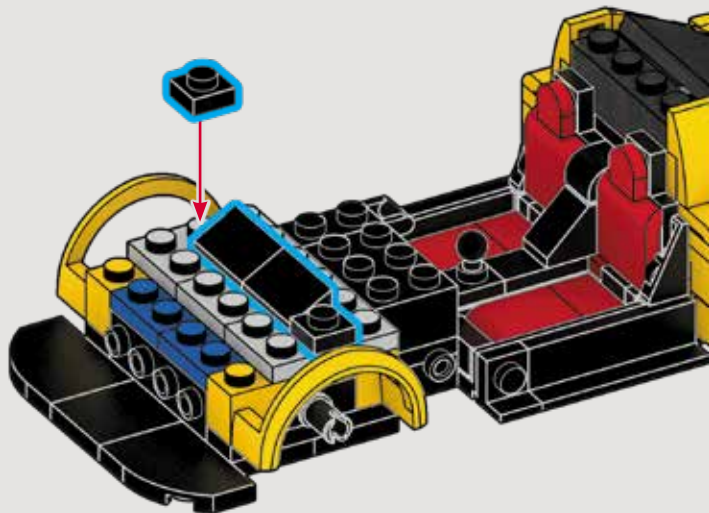

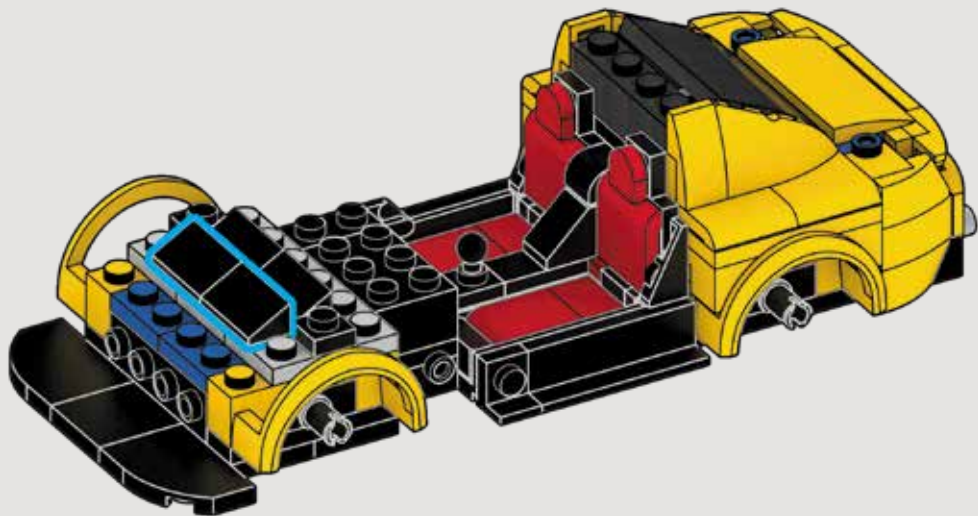
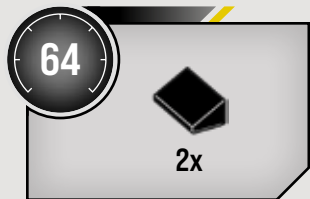

65

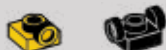

2x

2x



1x

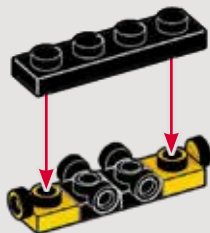

66



2x

1x

1x

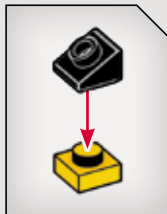
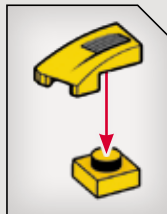

1



2

67



2x

1x

1x

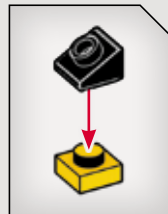
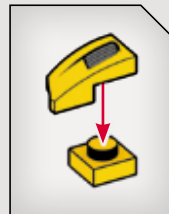

1



2

68

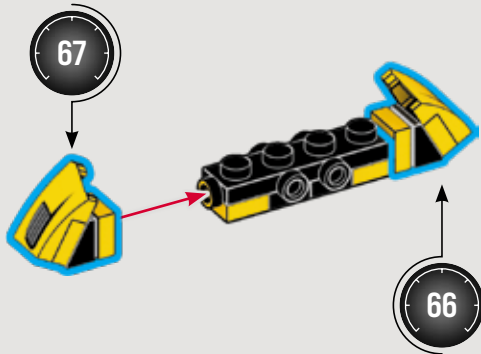

69

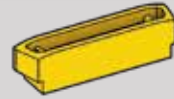

1x

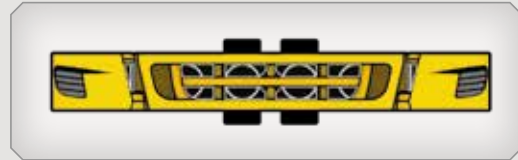

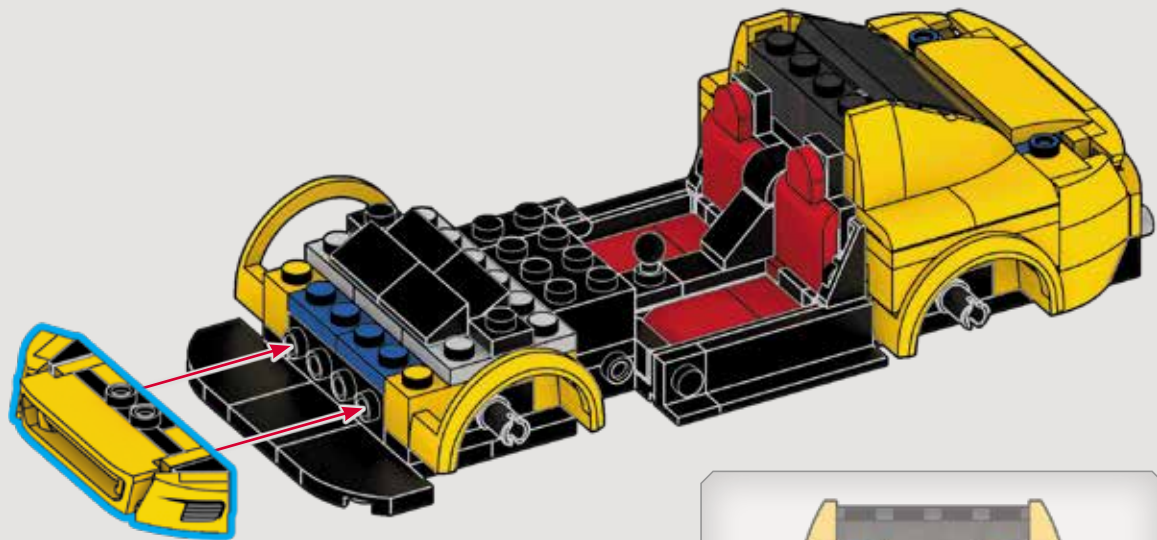

71



1x



1x



1x



1x

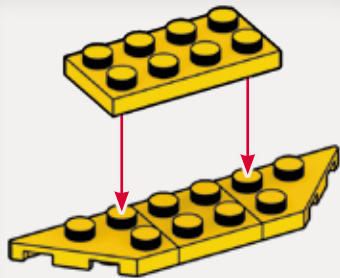

1



2

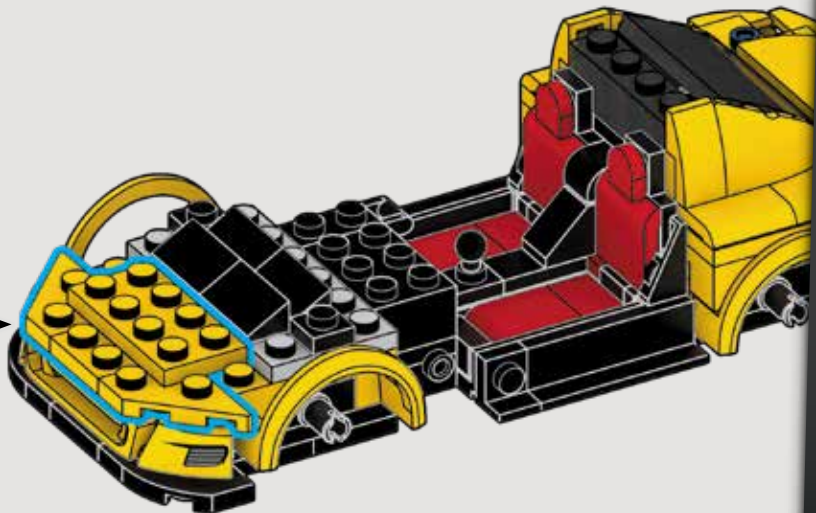

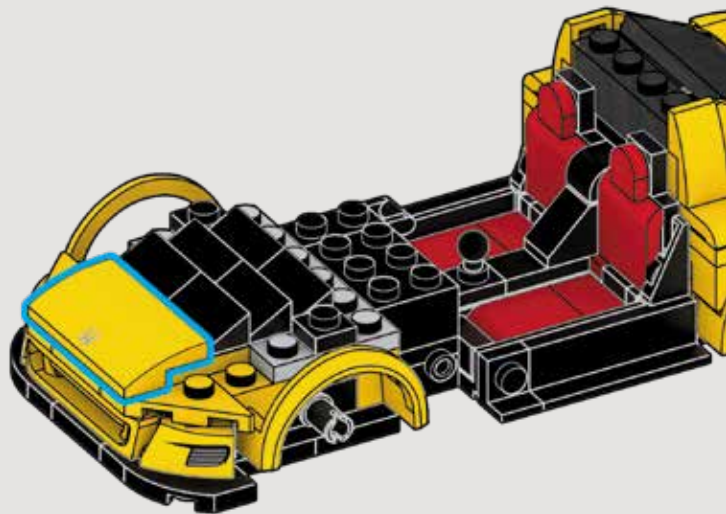
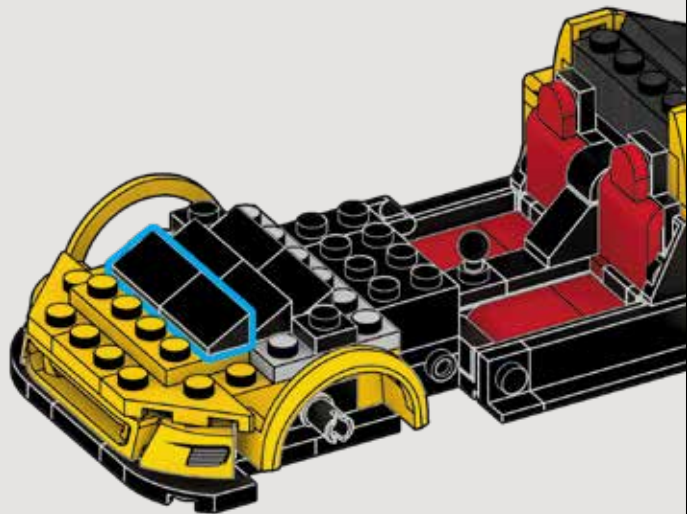
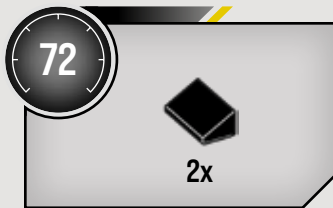

74



1x



1x

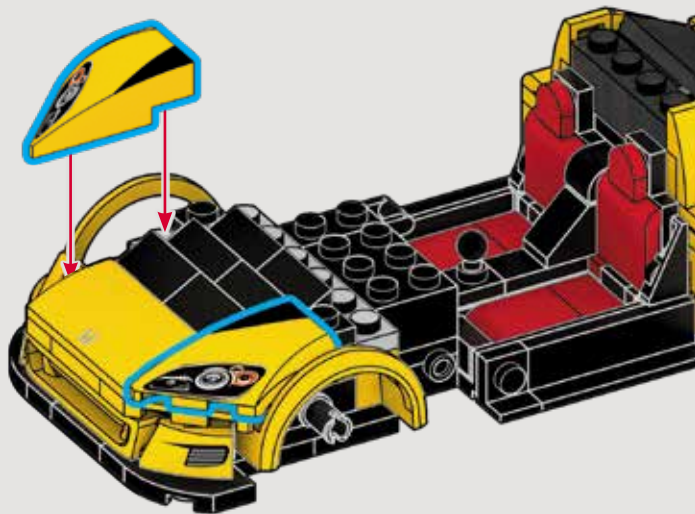

1

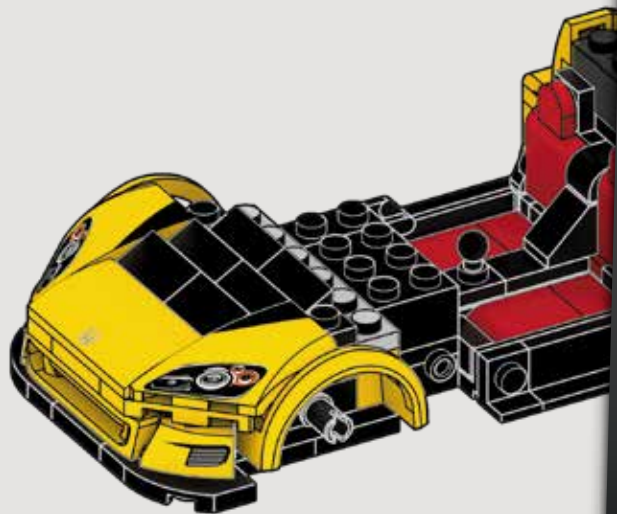

2

75



1x



1x



1x

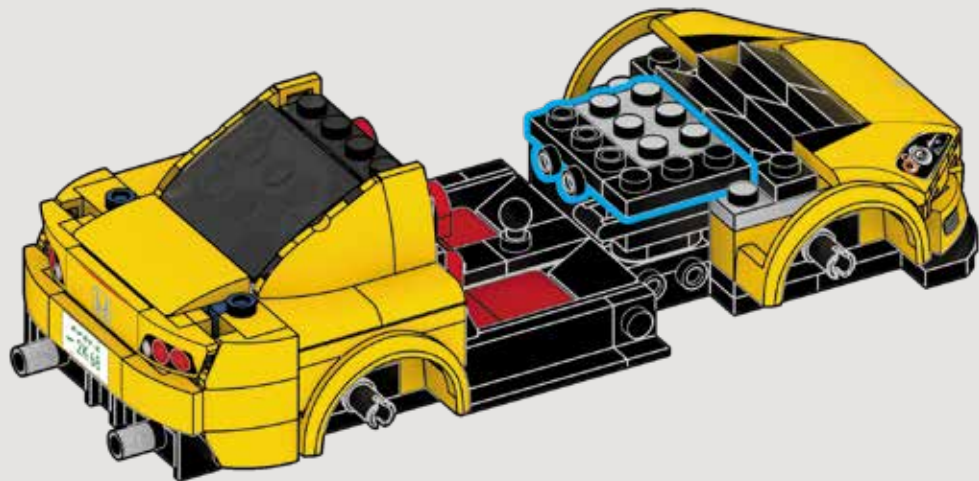

76



1x



1x

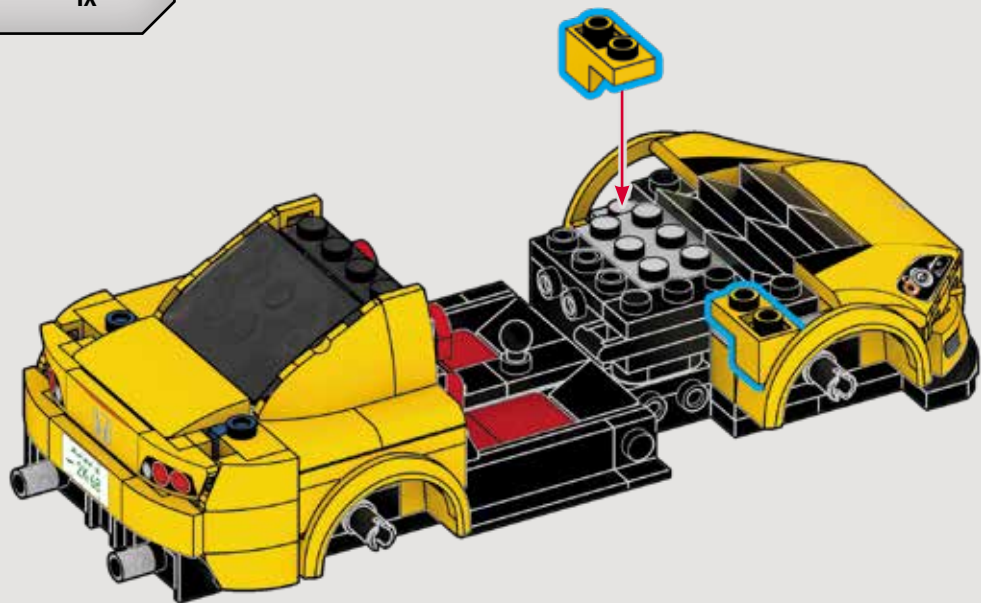

77



1x



1x

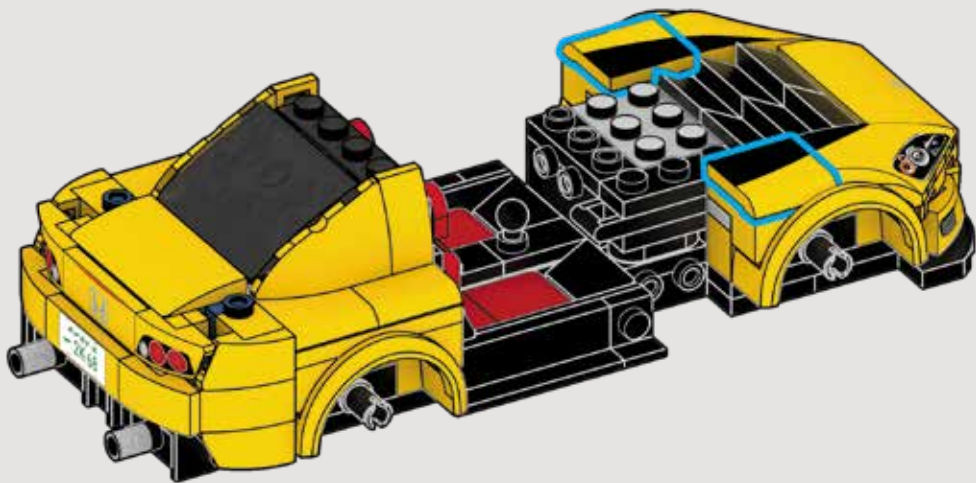

78



1x



1x



1x

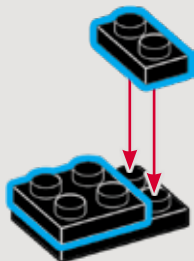

79



1x



1x



1x

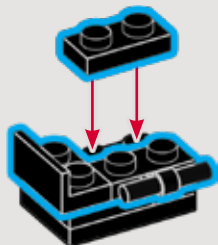

80



1x



1x



1x

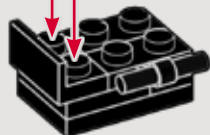
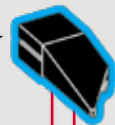
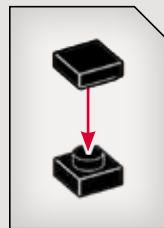

81

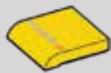

1x



1x

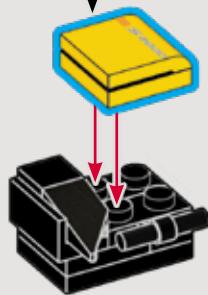
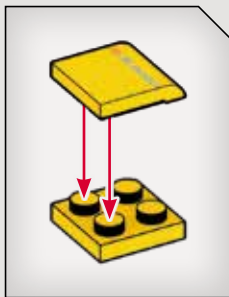

1

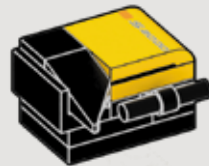

2

82



1x



1x



1x

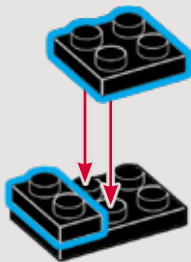

83



1x



1x



1x

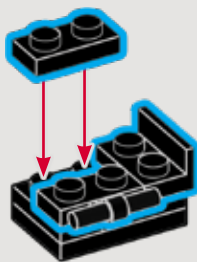

84



1x



1x



1x

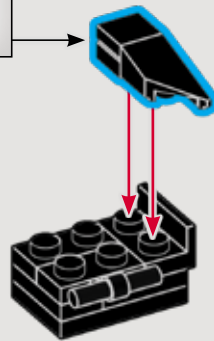
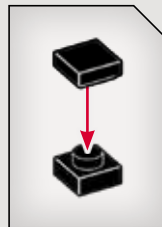

85



1x



1x

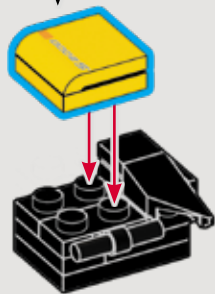
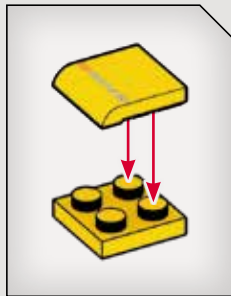

1



2

86

81

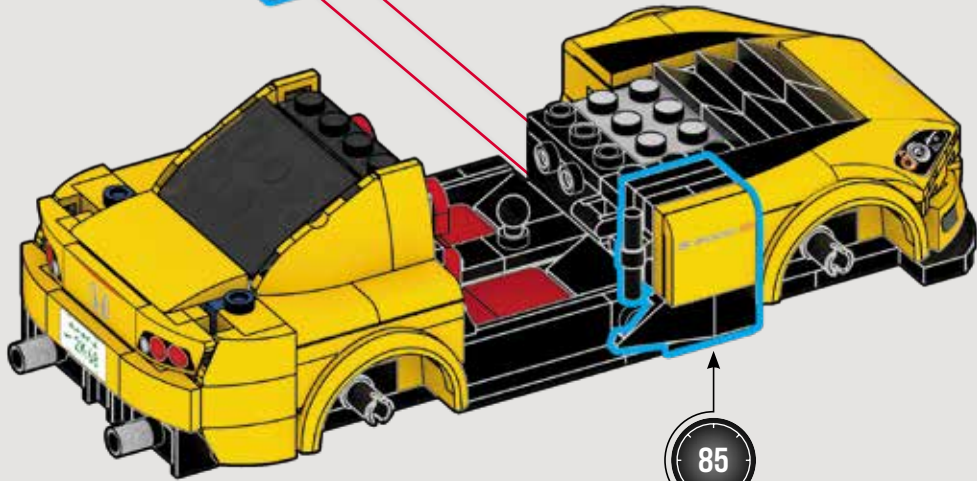
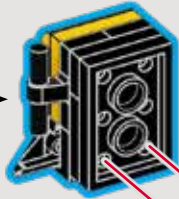

85

87

1x3



1x

2x3



1x

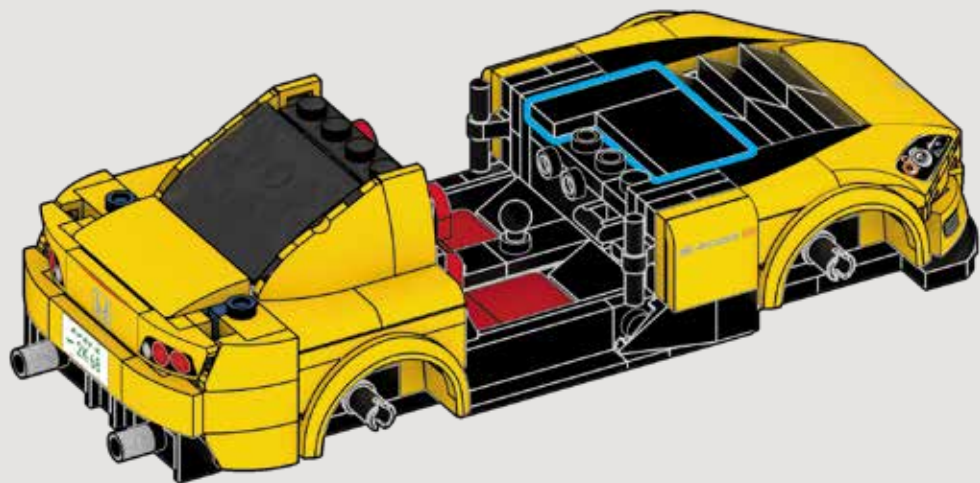

88



1x



1x



1x



1x



1



2



3

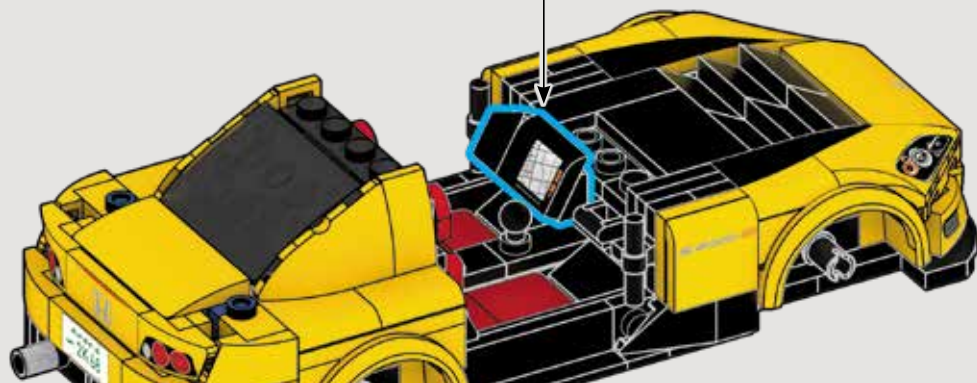

89



1x



1x

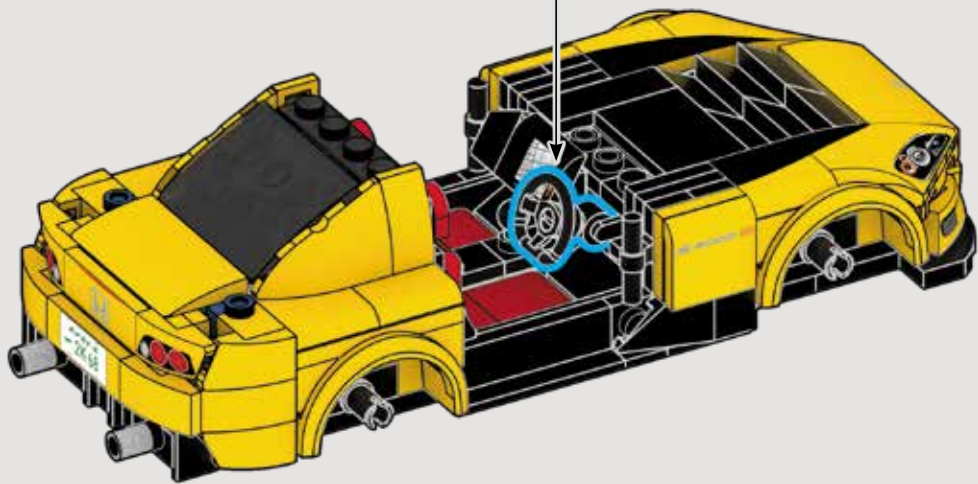
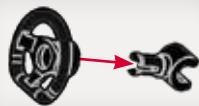

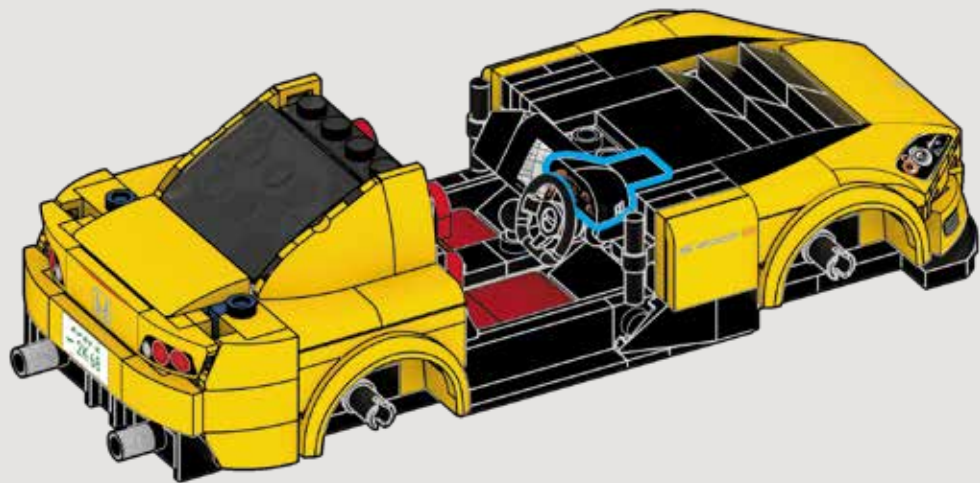

91



1x



1x



1x



1x

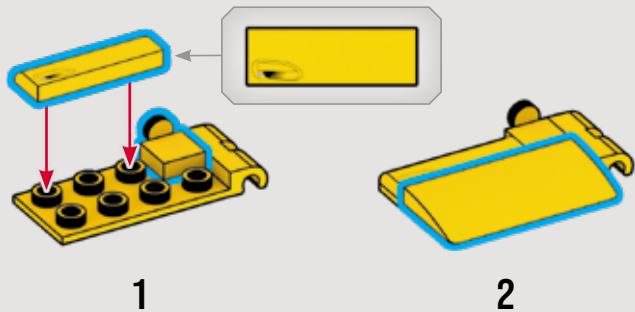

1

2

92



1x



1x



1x



1x

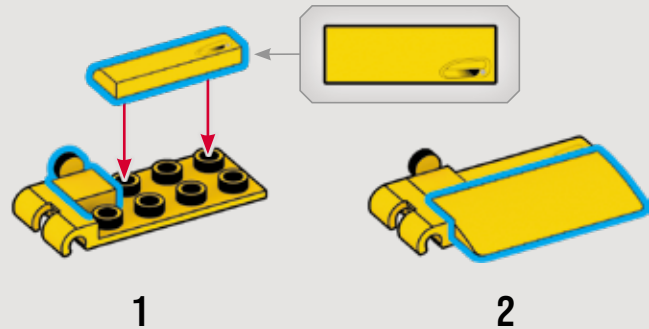

1

2

93

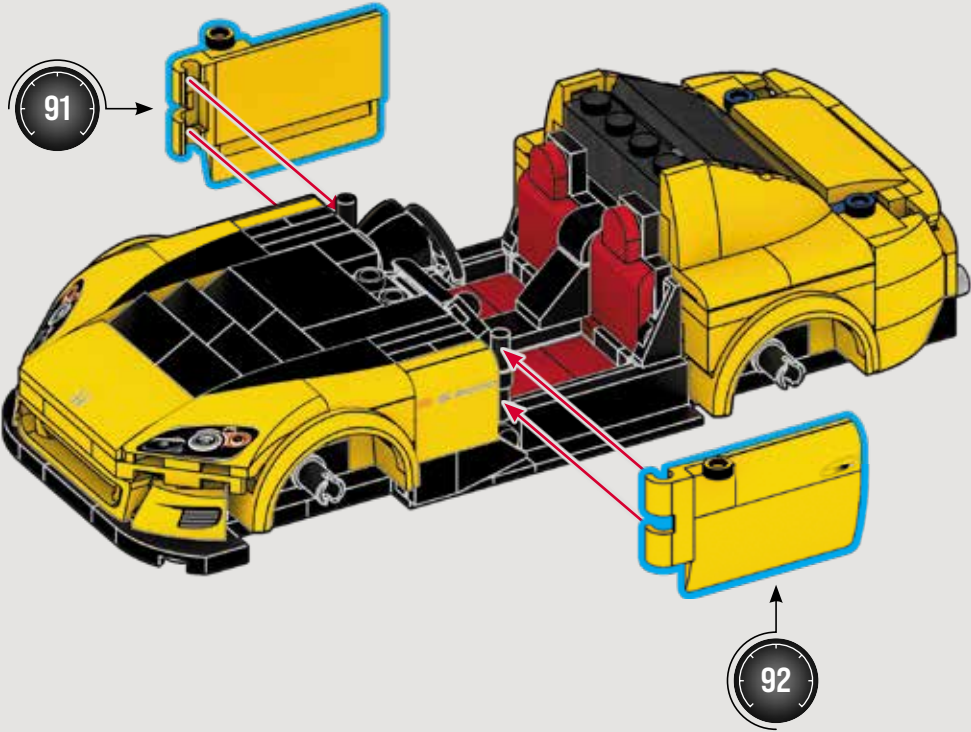

94



1x



1x

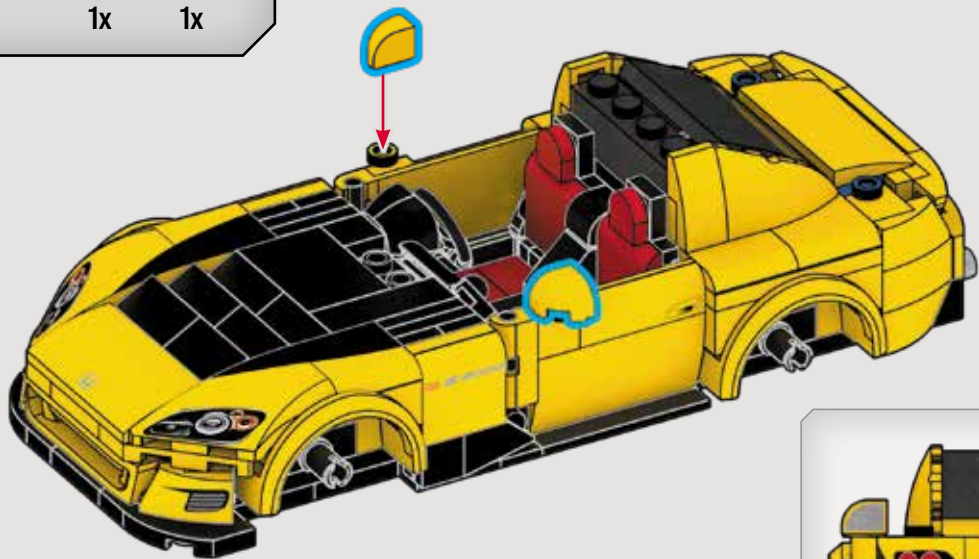

95

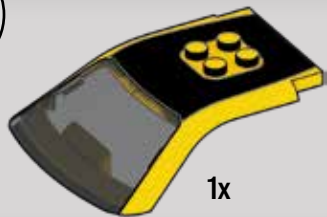

1x

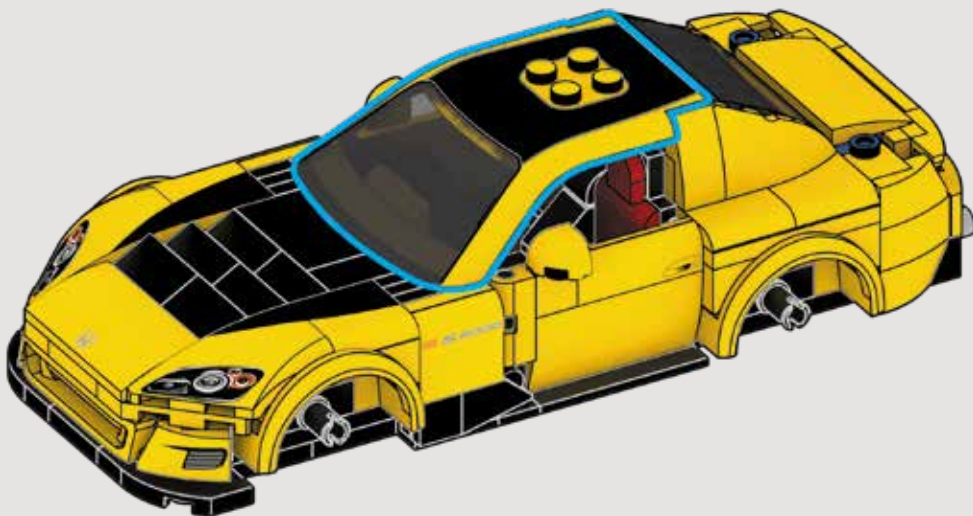

Always committed to authenticity, our designers developed this specific windshield frame to replicate the S2000.

Toujours passionnés par l'authenticité, nos designers ont conçu ce cadre de pare-brise unique afin de reproduire celui de la S2000.

Nuestros diseñadores, fieles a su compromiso con la autenticidad, han creado este marco de parabrisas especialmente diseñado para reproducir con exactitud el S2000.

Unseren Designern ist Authentizität sehr wichtig, deshalb haben sie diesen speziellen Windschutzscheibenrahmen entwickelt, um den S2000 detailgetreu nachzubilden.



96



1x

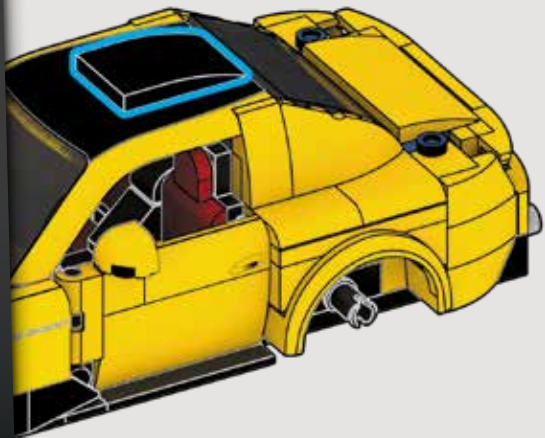

97

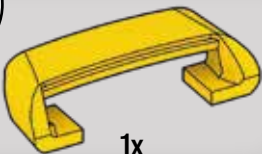

1x

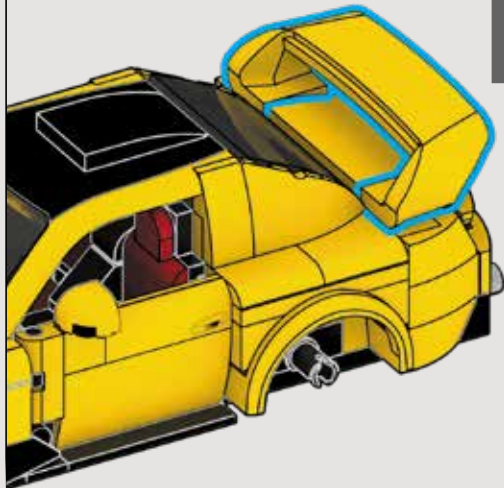

Our design team created this piece specifically to replicate the S2000's spoiler.

Notre équipe de designers a créé cette pièce spécialement pour restituer l'aileron de la S2000.

Nuestro equipo de diseño ha creado esta pieza específicamente para replicar el alerón del S2000.

Unser Design-Team hat dieses Teil speziell entwickelt, um den Spoiler des S2000 nachzubilden.

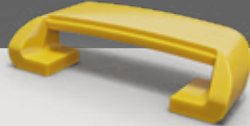

98

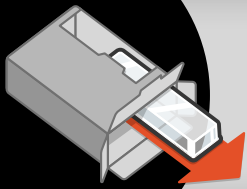

4x

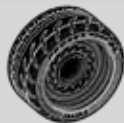

4x

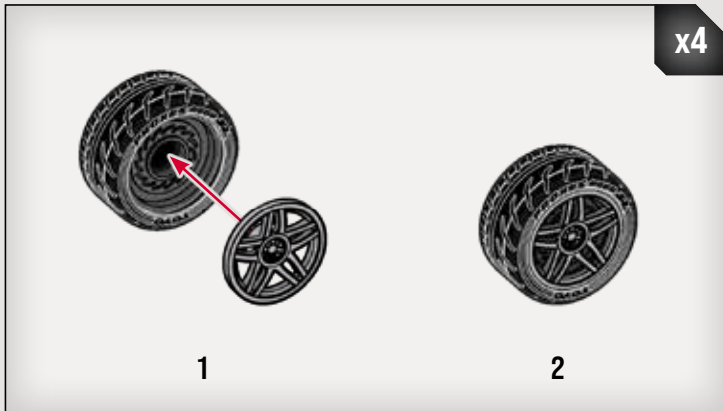

Features officially licensed Toyo Tires Proxes R888R tires.

Comprend des pneus Toyo Tires Proxes R888R sous licence officielle.

Incluye neumáticos Proxes R888R de Toyo Tires con licencia oficial.

Mit offiziell lizenzierten Toyo Tires Proxes R888R-Reifen.



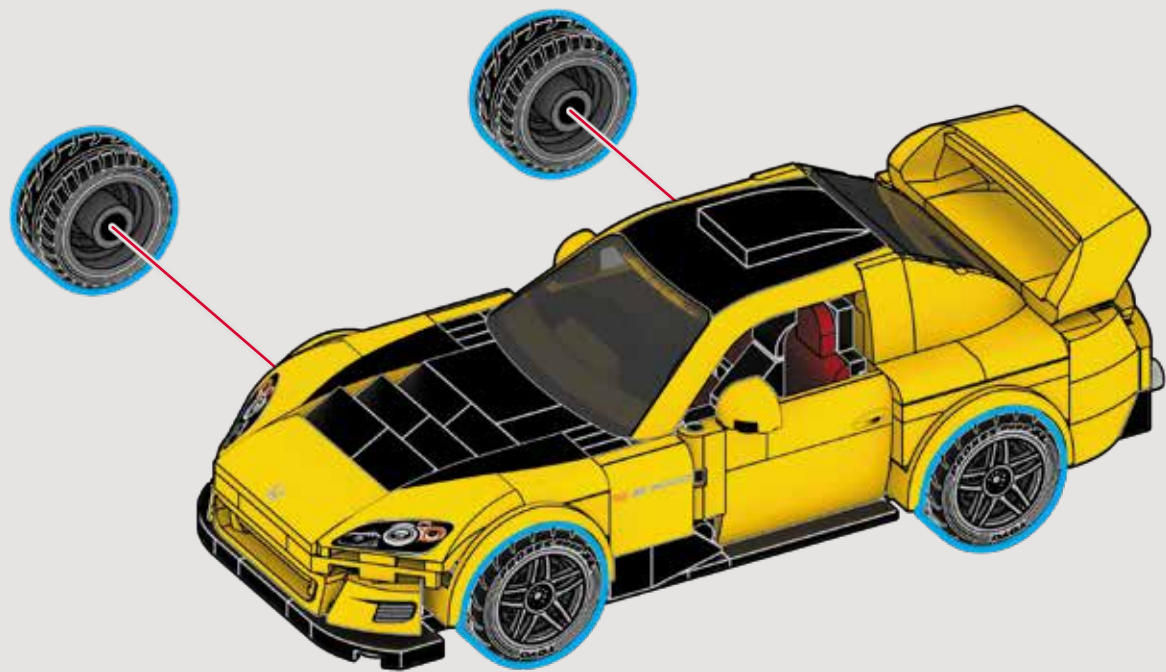

100

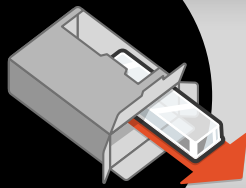

1x

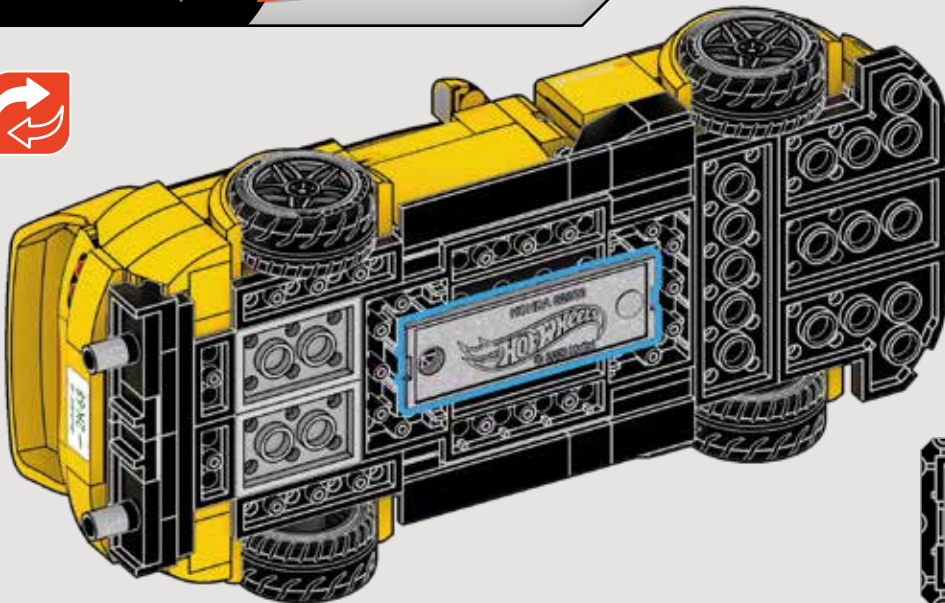

The metal signature plate doubles as a keychain!

La plaque de signature moulée en métal sert également de porte-clés !

¡La matrícula de metal sirve también de llavero!

Das „Signature Plate“ aus Metall lässt sich auch als Schlüsselanhänger verwenden!



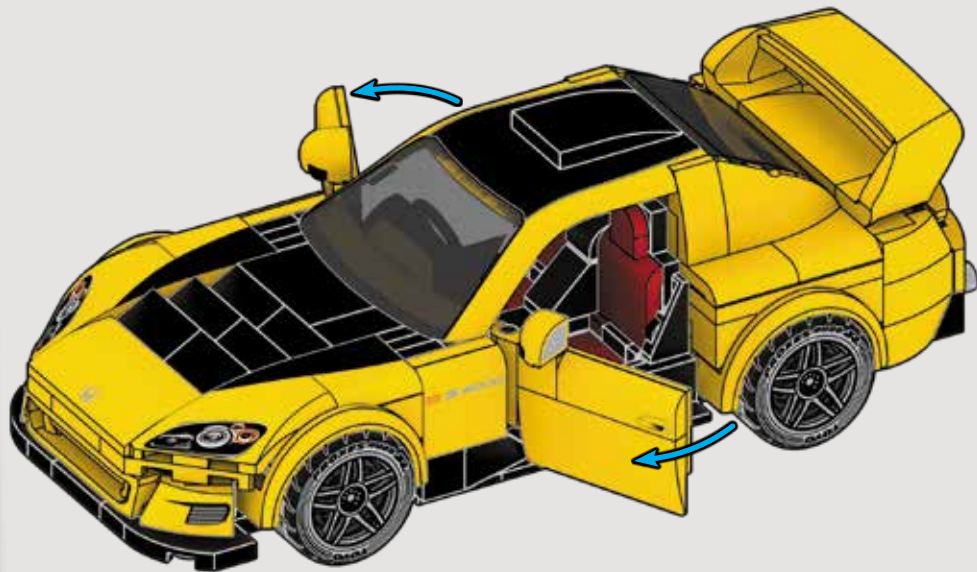

The S2000's doors open & close for 2 ways to display!

Les portes du S2000 s'ouvrent et se ferment pour pouvoir exposer le véhicule de 2 façons !

¡Las puertas del S2000 se abren y se cierran para exhibirlo de dos formas diferentes!

Die Türen des S2000 lassen sich öffnen und schließen. So kann er auf zwei verschiedene Weisen ausgestellt werden.



You've completed your '07 Honda S2000!
Notice extra pieces? Don't worry – we included those in case any get misplaced!

¡Has completado tu '07 Honda S2000!
¿Detectas piezas adicionales? No te preocupes.
Las hemos incluido en caso de que se extravíe alguna.

Vous avez complété votre '07 Honda S2000 !
Vous remarquez des pièces supplémentaires ? Ne vous inquiétez pas : nous les avons inclus au cas où certaines pièces se perdraient quelque part.

Du hast den Bau deines '07 Honda S2000 fertiggestellt!
Zusätzliche Teile gefunden? Keine Sorge – wir haben sie hinzugefügt,
falls welche verloren gehen!

CUSTOMIZE YOUR CAR / PERSONNALISEZ VOTRE VOITURE

PERSONALIZA TU COCHE / DAS AUTO INDIVIDUELL GESTALTEN

77



80

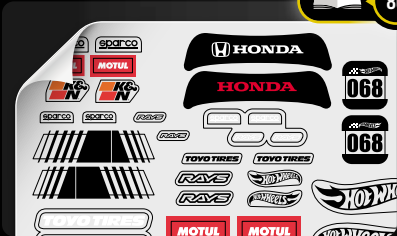

76

Most models can be built one at a time. / La plupart des modèles peuvent être construits un à la fois. / Die meisten Modelle können eines nach dem anderen gebaut werden. / La maggior parte dei modelli possono essere realizzati uno per volta. / De meeste modellen kunnen één voor één gebouwd worden. / La mayoría de modelos se pueden construir de uno en uno. / A maioria dos modelos pode ser construída separadamente. / De flesta modeller kan byggas en i taget. / Useimmat mallit voidaan rakentaa yksi kerrallaan. / De fleste modeller kan bygges enkeltvis. / De fleste modellene kan bygges en om gangen. / Większości modeli nie da się budować jednocześnie z innymi. / Většinou lze najednou sestavit pouze jeden model. / Väčšina modelov môže byť zostavená iba raz. / A modellek többségéből egyszerre csak egy építhető. / Большинство моделей могут быть собраны по одной за раз. / Τα περισσότερα μοντέλα μπορούν να κατασκευασθούν ένα ένα. / Modellerin çoğu ayrı ayrı inşa edilmeyle gerektirebilir. / يمكن تركيب التصاميم الواحد تلو الآخر.

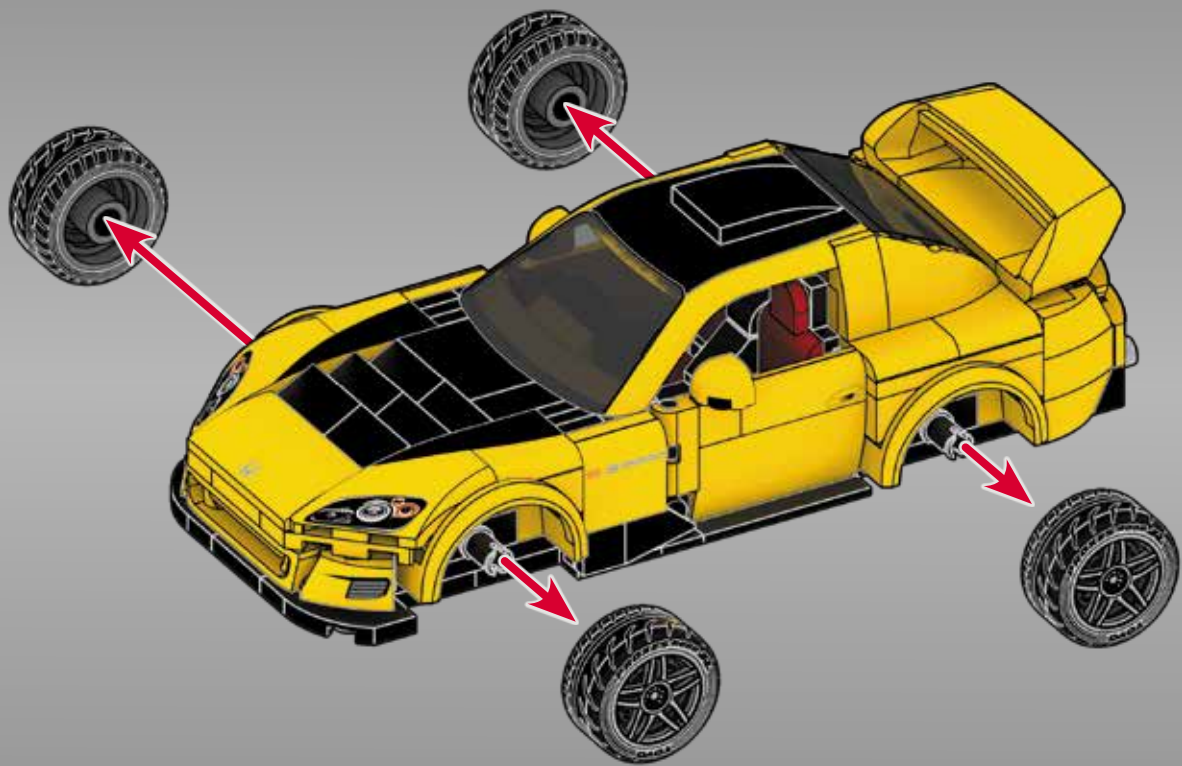

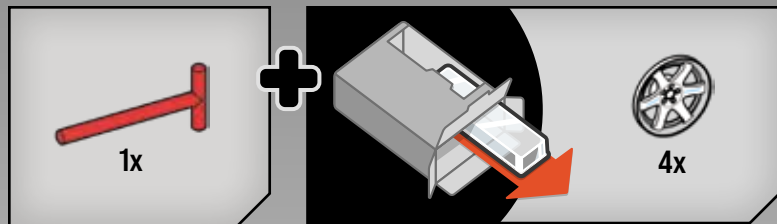

Features officially licensed
RAYS TE37 wheel covers.

Comprend des enjoliveurs RAYS TE37
sous licence officielle.

Incluye tapacubos RAYS TE37
con licencia oficial.

Mit offiziell lizenzierten
TE37-Radkappen von RAYS.

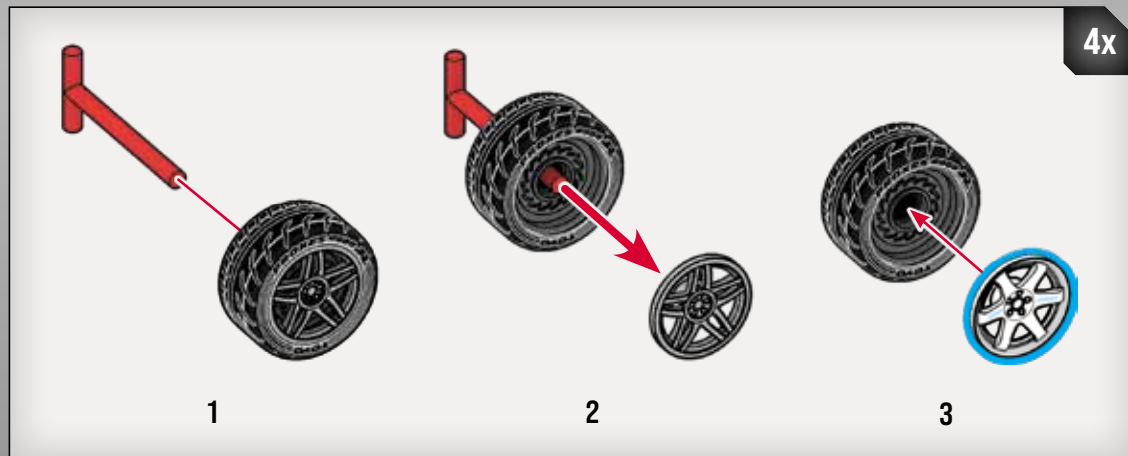

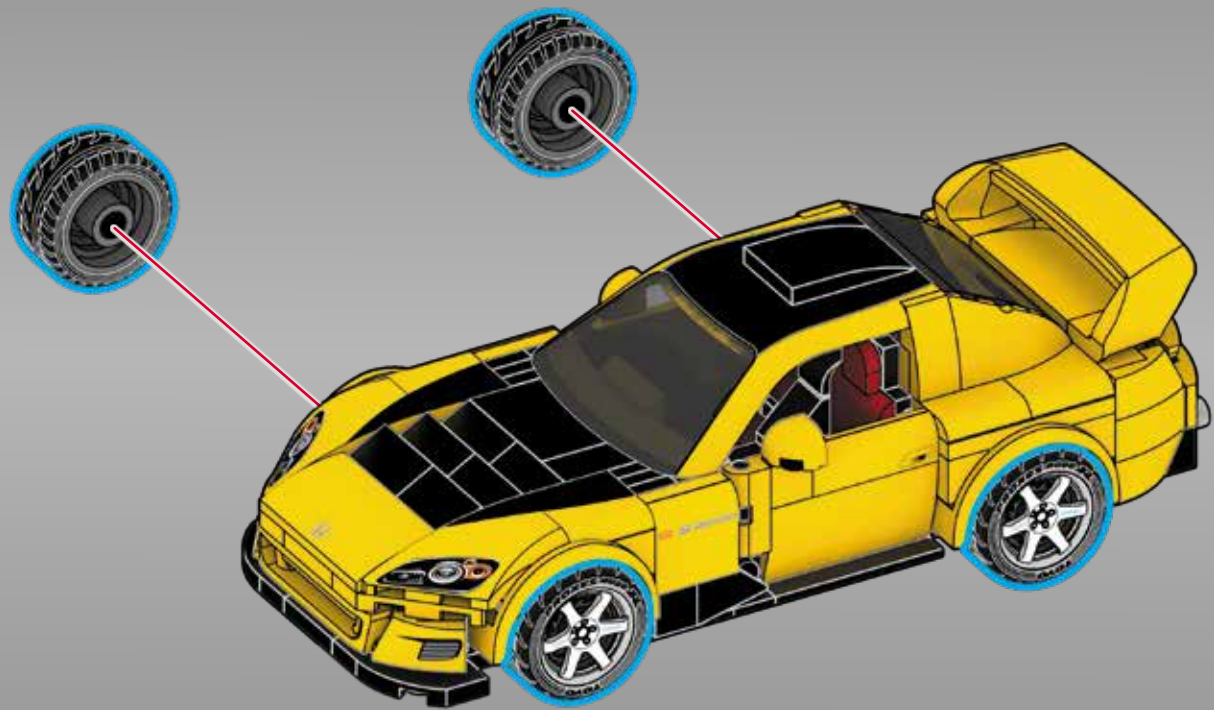

MAKE IT YOUR OWN WITH **DECALS**

PERSONNALISEZ-LA AVEC DES **AUTOCOLLANTS**

PERSONALÍZALO CON PEGATINAS / MIT AUFKLEBERN INDIVIDUELL GESTALTEN

We've included officially licensed decals of Honda, RAYS, Toyo Tires, Motul, Sparco, and K&N to finish off your ride. You can customize your ride the way you like.

Nous avons inclus des autocollants Honda, RAYS, Toyo Tires, Motul, Sparco et K&N sous licence officielle. Vous pouvez ainsi personnaliser votre bolide à votre guise.

Hemos incluido pegatinas con licencia oficial de Honda, RAYS, Toyo Tires, Motul, Sparco, y K&N. Puedes personalizar tu coche como más te guste.

Mitgeliefert werden offiziell lizenzierte Aufkleber von Honda, RAYS, Toyo Tires, Motul, Sparco, und K&N. So lässt sich der Rennwagen ganz individuell gestalten.

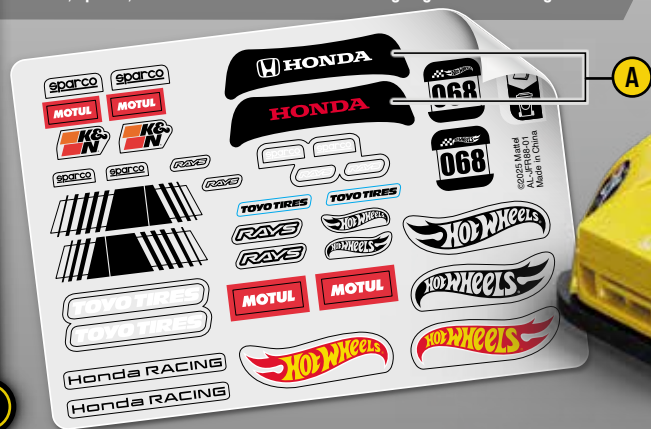



THIS IS HOW WE PLACED THE DECALS. HOW WILL YOU DO IT?

*VOICI COMMENT NOUS AVONS PLACÉ LES AUTOCOLLANTS.
COMMENT ALLEZ-VOUS PROCÉDER ?*

*ASÍ ES COMO UBICAMOS LOS AUTOADHESIVOS. ¿CÓMO LO HARÍAS TÚ?
DAS IST EINE MÖGLICHKEIT DIE AUFKLEBER ANZUBRINGEN.
WIE SIEHT DEINE GESTALTUNG AUS?*





Hot Wheels
PREMIUM
SERIES

SCALE / ÉCHELLE
ESCALA / MABSTAB
1:12



HWW25

3 SERIES TO BUILD
3 SÉRIES À CONSTRUIRE

3 SERIES PARA CONSTRUIR
3 SERIEN ZUM ZUSAMMENBAUEN

MATTELBRICKSHOP.COM



Hot Wheels
ELITE
SERIES™

SCALE / ÉCHELLE
ESCALA / MABSTAB
1:16



JFT18

JGR31

Hot Wheels
SPEED
SERIES™

SCALE / ÉCHELLE
ESCALA / MABSTAB
1:32



JFR89

JFR88

JGR28

ADVERTISEMENT • PUBLICITÉ • PUBLICIDAD • WERBUNG

"Mercedes-Benz" and  are the intellectual property of Mercedes-Benz Group AG. They are used by Mattel, Inc. under license.

Set(s) sold separately and subject to availability. / Ensemble(s) vendu(s) séparément. Certains produits peuvent ne pas être commercialisés.

Se vende(n) por separado y está(n) sujeto(s) a disponibilidad. / Conjunto(s) vendido(s) em separado e sujeito(s) a disponibilidade. / Set in vendita separatamente, secondo disponibilità. / Das/Die Set(s) sind separat erhältlich. / Zestaw(ly) sprzedawany(e) oddzielnie w zależności od dostępności. / Set(s) apart verkrijgbaar en afhankelijk van beschikbaarheid. / Набор(-ы) продаются отдельно, при наличии. / Sæt sælges separat og så længe lager haves. / Seten säljs separat så länge lagret räcker. / Settet/settene selges separat så langt lageret rekker. / Pakkaus/pakkaukset myydään erikseen, saatavuus voi vaihdella. / Το(α) σετ πωλούνται ξεχωριστά και ανάλογα με τη διαθεσιμότητα. / Setler ayrı olarak satılır ve stoklarla sınırlıdır. / Set (sety) se prodává (prodávají) samostatně dle aktuální nabídky. / Súprava/-y sa predáva(jú) samostatne a podľa dostupnosti. / A készlet(ek) külön kapható(k), az elérhetőség változhat. / セット商品は別売りになります。在庫状況は別途ご確認をお願いします。 / 每套单独发售，按供货情况决定。



General Motors
Trademarks used
under license to
Mattel, Inc.



Officially licensed by AUDI AG
Sous licence officielle d'AUDI AG

تباع المجموعة أو المجموعات على حدة وتخضع لتوافرها.

1x
AM82091F



2x
AS-74397-SLV01



1x
ME82566F



2x
ME76204AMC



4x
ME07223F



2x
ME82424F



8x
ME03328BYE



8x
ME03328F



2x
ME82529BYE



2x
ME79665F



2x
ME79590BYE



2x
ME79590B



2x
ME79590F



2x
ME80120F



1x
ME74299F



3x
ME72001F



1x
AS-JFR88-18



1x
AS-JFR88-19



1x
ME17787F



2x
ME82526F



2x
ME82537F



1x
ME82722F



1x
ME82403F



1x
ME82404F



3x
ME22501AMC



2x
ME73758F



2x
ME07590F



7x
ME09393BYE



6x
ME09393F



1x
ME09393B



1x
ME80174F



5x
ME79070F



2x
ME76467F



4x
ME82538F



1x
ME18272F



1x
ME17129F



1x
ME17130F



2x
ME74427BYE



1x
AS-JFR88-12



1x
AS-JFR88-07



2x
ME74426BYE



1x
AS-JFR88-08



1x
AS-JFR88-10



6x
ME83417BYE



2x
ME16843F



1x
AS-JFR88-21



3x
ME82939BYE



3x
ME82940BYE



8x
ME18549F



2x
AMD4429BAS



1x
ME01322F



1x
ME09013BYE



2x
ME18601F



1x
ME16954F



2x
ME15484BYE



4x
ME15484B



2x
ME18293F



4x
AS-82522-SLV01



4x
AS-JFR88-17



1x
ME82707F



7x
ME03773BYE



4x
ME03773F



1x
AS-JFR88-20



1x
AS-JFR88-14



1x
AS-JFR88-16



1x
AS-JFR88-05



1x
AS-JFR88-04



4x
ME82521BYE



4x
ME82521AMC



4x
ME81385F



1x
ME09023BLG





4x
AS-JFR88-23



1x
ME80966F



1x
AS-JFR88-09



1x
AS-JFR88-11



1x
ME01314F



1x
ME01314BYE



1x
ME82281F



2x
ME81259F



1x
AS-JFR88-13



1x
AS-JFR88-15



3x
ME16384BYE



1x
ME76205BYE



1x
ME76206BYE



1x
ME81639F



8x
ME03772BLG

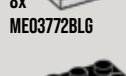

2x
ME03772F



1x
ME03873F



1x
ME75525BYE



1x
ME75526BYE



1x
AS-JFR88-02



1x
AS-JFR88-03



5x
ME09593F



2x
ME82530F

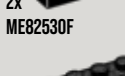

1x
AM01087BAS



2x
ME01087F



2x
ME17503F



1x
ME82535BYE

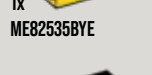

1x
ME81604F



1x
ME82540F



1x
ME82539F



1x
ME82581F



1x
ME18299B



4x
ME09493BYE



2x
ME82519BYE



1x
ME09033F



3x
ME82048BYE



1x
AS-JFR88-01



1x
AM81605BAS

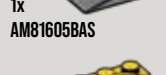

4x
ME82534BYE



1x
ME72089EA

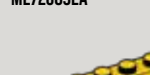

1x
ME07475BYE

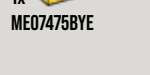

1x
ME09292F



1x
AS-82517-PLT01



1x
ME01480F



1x
ME82533BYE



1x
ME80855EA



1x
ME82518F



1x
JG111-9796



1x
AS-JFR88-22

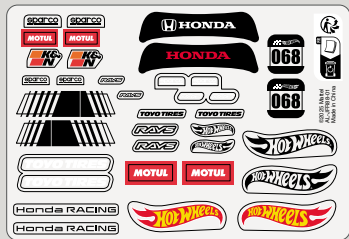

AL-JFR88-01

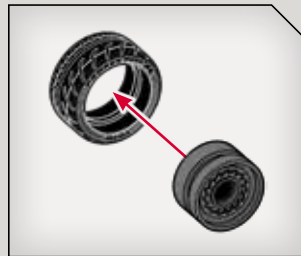

Mattel Europa B.V., Gondel 1, 1186 MJ Amstelveen, Nederland. Mattel U.K. Limited, The Porter Building, 1 Brunel Way, Slough SL1 1FQ, UK. Mattel Barbie (Shanghai). Trading Co., Ltd. Room 2005, 20th Floor, 899 Ruining Road, Xuhui District, Shanghai, 200232, PRC. Customer Care Line: 400-819-8658. Kids Kingdom Limited, Room 1908-9, Gala Place, 56 Dundas Street, Mongkok, Kowloon, Hong Kong, P.R.C. Customer Care Line: (852)2782-0766. CHICKABIDDY CO., LTD, F5, No. 186, Sec. 4, Nanjing E. Rd., Taipei 10595, Taiwan region. Customer Care Line: 0800 001 256. Diimport & Diedarkan Oleh: Mattel Continental Asia Sdn Bhd. Level 19, Tower 3, Avenue 7, No. 8 Jalan Kerinchi, Bangsar South, 59200 Kuala Lumpur, Malaysia. Mattel South Africa (PTY) LTD, Office 102 I3, 30 Melrose Boulevard, Johannesburg 2196. Mattel Australia Pty. Ltd., 658 Church St., Richmond, Victoria, 3121. Consumer Advisory Service - 1300 135 312. 16-18 William Pickering Drive, Albany 1331, Auckland. Mattel Oyuncakçılık Tic. Ltd. Şti. İçerenköy Mah., Umut Sokak No: 10 - 12, Quick Tower kat:2 içkapı no:15 Ataşehir 34752, İstanbul, Türkiye. Tel: 0216 570 75 00. Импортёр/Уполномоченная организация: ООО "МАТТЕЛ" Российская Федерация, 105120 Москва, 2-й Сыромятинский переулок, 1; +7 495 287 79 39. Mattel, Inc., 636 Girard Avenue, East Aurora, NY 14052, U.S.A. Mattel Canada Inc., Mississauga, Ontario L5R 3W2. Consumer Services/Service à la clientèle : 1-800-524-8697 and/et 1-800-432-5437 for Fisher Price products/pour les produits Fisher Price. Importado y distribuido por Mattel de México, S.A. de C.V., Miguel de Cervantes Saavedra No. 193, Pisos 10 y 11, Col. Granada, Alcaldía Miguel Hidalgo, C.P. 11520, México, Ciudad de México. R.F.C. MME-920701-NB3. Tels.: 59-05-51-00 Ext. 5206 ó 01-800-463-59-89. Mattel Chile S.A., Pdte. Riesco 5561, Of. 203-204 PS2, Las Condes, Santiago. Servicio al consumidor Venezuela: Tel.: 0-800-100-9123. Mattel Argentina, S.A., Av. Libertador 1000, Piso 11 – Oficinas 109 y 111, Vicente López – Prov. Buenos Aires. Tel.: 0800-666-3373. Mattel Colombia, S.A., Calle 123#7-07 P.5, Bogotá. Mattel Perú, S.A., Av. Juan de Arona # 151, Centro Empresarial Juan de Arona, Torre C, Piso 7, Oficina 704, San Isidro, Lima 27, Perú. RUC: 20425853865. Reg. Importador: 02350-12-JUE-DIGESA. Tel.: 0800-54744. E-mail Latinoamérica: servicio.clientes@mattel.com. Distribuido por: Mattel do Brasil Ltda.- CNPJ : 54.558.002/0001-20 - Av. Dr. Churci Zaidan, 296 - 15º. Andar - 04583-110 - Vila Cordeiro - São Paulo - SP - Brasil. Serviço de Atendimento ao Consumidor: Contato: <https://faleconosco.mattel.com.br/Contato>. Email: sac.matteldobrazil@mattel.com.

**Missing pieces?
Pièces manquantes?**

¿Partes faltantes?
Perdeu peças?
Fehlen Teile?



service.mattel.com

MADE IN CHINA. VEHICLE MADE IN CHINA, MALAYSIA, INDONESIA OR THAILAND AS MARKED.

FABRIQUÉ EN CHINE. VÉHICULE FABRIQUÉ EN CHINE, EN MALAISIE, EN INDONÉSIE OU EN THAÏLANDE COMME INDIQUÉ.

HECHO EN CHINA. VEHÍCULO HECHO EN CHINA, MALASIA, INDONESIA O TAILANDIA, SEGÚN LO INDICADO.

FABRICADO NA CHINA. VEÍCULO FABRICADO NA CHINA, MALÁSIA, INDONÉSIA OU TAILÂNDIA, CONFORME INDICADO.

ИЗГОТОВЛЕНО В КИТАЕ. АВТОМОБИЛЬ ИЗГОТОВЛЕН В КИТАЕ, МАЛАЙЗИИ, ИНДОНЕЗИИ ИЛИ ТАИЛАНДЕ СОГЛАСНО МАРКИРОВКЕ.

ÇİN'DE ÜRETİLMİŞTİR. ARAÇ, BELİRTİLDİĞİ ŞEKİLDE ÇİN, MALEZYA, ENDONEZYA VEYA TAYLAND'DA ÜRETİLMİŞTİR.

صنعت في الصين. صنعت السيارة في الصين أو ماليزيا أو اندونيسيا أو تايلاند كما هو مذكور.

TOYO TIRES

Toyo Tires trademark used under license.

sparco

RAYS

Patent pending / Brevet en instance



Ⓟ D781,964, D797,203, D835,727, D841,101



K&N and the K&N logo are registered trademarks of K&N ENGINEERING, INC., and used under license.

MOTUL

Mattel uses Motul trademark and copyright under license.
Mattel utilise la marque Motul sous licence.

©2025 Mattel. MATTEL, MATTEL BRICK SHOP and associated trademarks and trade dress are owned by Mattel. ® and ™ designate U.S. trademarks of Mattel, except as noted. MATTEL, MATTEL BRICK SHOP ainsi que les marques et designs y afférents appartiennent à Mattel. ® et ™ désignent des marques de Mattel aux États-Unis, sauf indication contraire.



Inspirer les générations par le jeu

MATTELBRICKSHOP.COM

Printed in China / Imprimé en Chine
AD-JFR88-01



HONDA

Official Licensed Product
Produit Sous Licence Officielle

Designed, manufactured, and distributed by or for Mattel, Inc. Intellectual property of Honda Motor Co., Ltd. used under license from American Honda Motor Co., Inc.



FR
DONNEZ
OU
RECYCLEZ



ASSOCIATION

OU



MAGASIN

OU



DÉCHÈTERIE

Adresses sur quefairedemesdechets.fr





HONDA

Official Licensed Product
Produit Sous Licence Officielle

'07 HONDA S2000

