



PLEASE KEEP THESE INSTRUCTIONS FOR FUTURE REFERENCE AS THEY CONTAIN IMPORTANT INFORMATION. • GUARDA ESTAS INSTRUCCIONES PARA FUTURA REFERENCIA, YA QUE CONTIENEN INFORMACIÓN IMPORTANTE DE ESTE PRODUCTO. • CONSERVER CE MODE D'EMPLOI POUR S'Y RÉFÉRER AU BESOIN, CAR IL CONTIENT DES RENSEIGNEMENTS IMPORTANTS. • GUARDE ESTAS INSTRUÇÕES PARA FUTURA REFERÊNCIA, POIS CONTÉM INFORMAÇÕES IMPORTANTES.



ONE VEHICLE INCLUDED. ADDITIONAL VEHICLES SOLD SEPARATELY. NOT FOR USE WITH SOME HOT WHEELS® VEHICLES. COLORS AND DECORATIONS MAY VARY. • INCLUYE UN VEHÍCULO. LOS VEHÍCULOS ADICIONALES SE VENDEN POR SEPARADO. NO COMPATIBLE CON ALGUNOS VEHÍCULOS HOT WHEELS. LOS COLORES Y LAS DECORACIONES PUEDEN VARIAR. • CONTIENT UN VEHICULE. AUTRES VEHICULES VENDUS SÉPARÉMENT. NON COMPATIBLE AVEC CERTAINS VEHICULES HOT WHEELS. LES COULEURS ET LES MOTIFS PEUVENT VARIER. • UM VEÍCULO INCLUIDO. VEÍCULOS ADICIONAIS VENDIDOS SEPARADAMENTE. NÃO É COMPATÍVEL COM ALGUNS VEÍCULOS HOT WHEELS. AS CORES E AS DECORAÇÕES PODEM VARIAR.



**Easy Snap.
Connect.
Play.
Emboîter.
Connecter.
Jouer.**

Encaja rápido. Conecta. Juega.
Facil encaixa. Conecta. Brincar.

**INSTRUCTIONS • INSTRUCCIONES
MODE D'EMPLOI • INSTRUÇÕES**

HOTWHEELS.COM

4+

MATTEL

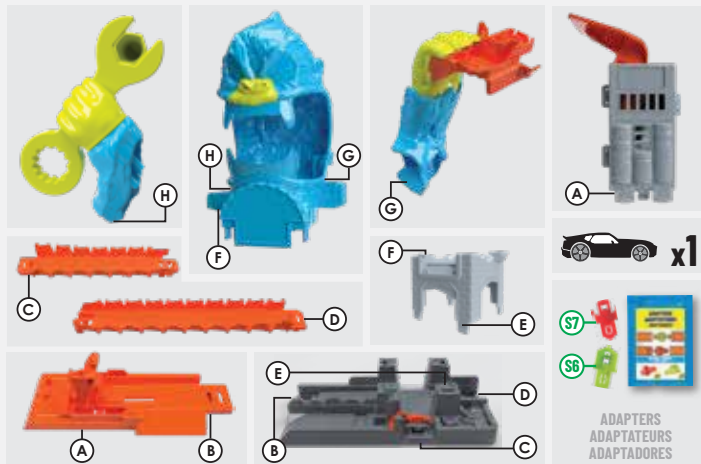

1**CONTENTS • CONTENIDO
CONTENU • CONTEÚDO****2****APPLY LABELS • PEGA LAS CALCOMANÍAS
APOSEZ LES AUTOCOLLANTS • COLAR ADESIVOS**

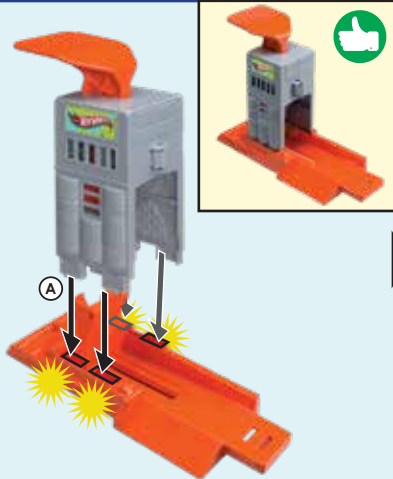
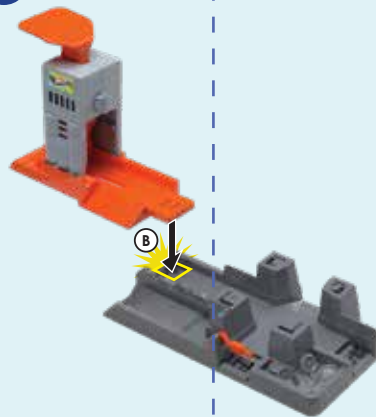
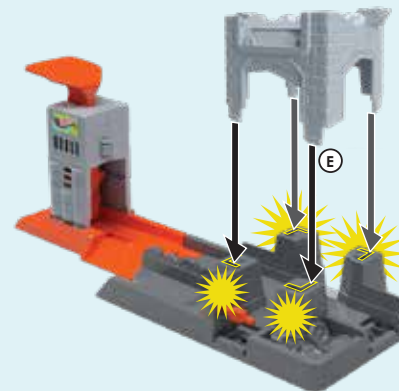
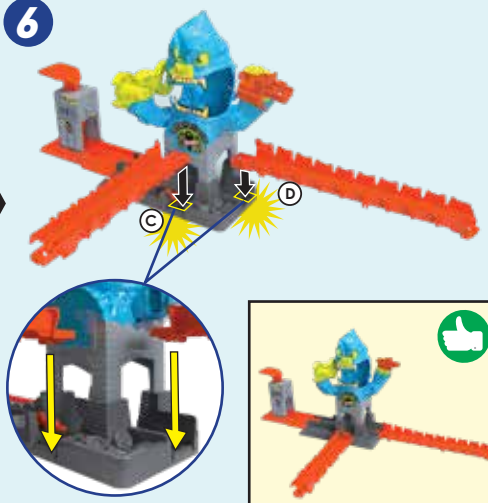
3**ASSEMBLY • MONTAJE
ASSEMBLAGE • MONTAGEM****KEY:
CONSEJO:
LÉGENDE:
CHAVE:****SNAP TO CONNECT.
ENCAJA PARA CONECTAR.
ENCLENCHEZ POUR CONNECTER.
ENCAIXE PARA CONECTAR.****ASSEMBLY COMPLETED.
ENSAMBLAJE COMPLETADO.
ASSEMBLAGE TERMINÉ.
MONTAGEM CONCLUÍDA.****ONE-TIME
ASSEMBLY.****MONTAJE
PERMANENTE.****ASSEMBLAGE
PERMANENT.****REQUER MONTAGEM
UMA ÚNICA VEZ.****1****2****3****4****5****6**

4

TO PLAY • PARA JUGAR • POUR JOUER • COMO BRINCAR

A

GORILLA ATTACK • ATAQUE DE GORILA • ATTAQUE DE GORILLE • ATAQUE DO GORILA

1

BEND & SNAP. • DOBLA Y ENCAJA.
PLIEZ ET ENCLENCHEZ.
DOBRE E PRENDA.

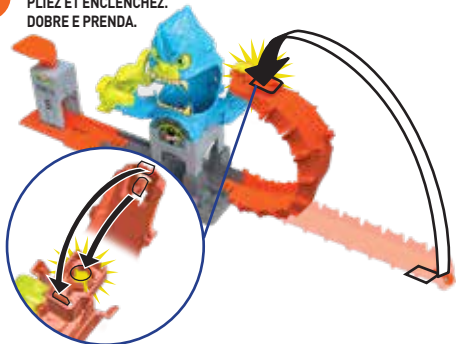

2

LOAD YOUR CAR.
COLOCA EL VEHÍCULO.
CHARGE LE VÉHICULE.
POSICIONE O SEU CARRO.



3

HIT THE WRENCH TO DEFEAT THE GORILLA!
¡GOLPEA LA LLAVE PARA VENCER AL GORILA!
APPUYEZ SUR LA CLÉ POUR VAINCRE LE GORILLE!
APERTE A CHAVE INGLESA PARA DERROTAR O GORILA!

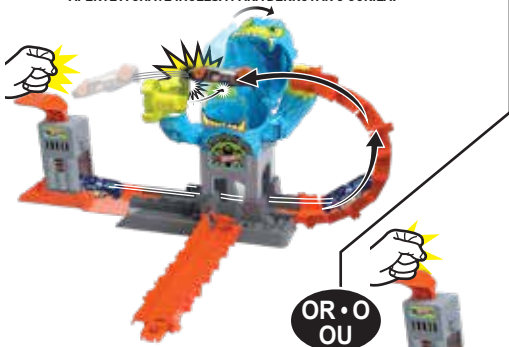

OR • O OR

GET EATEN!
¡SERÁS COMIDA!
SOIS DÉVORÉ!
SEJA DEVORADO!



TO RESET • PARA RESTABLECERLO
POUR RÉENLENCHEZ • REINICIAR



TURN OVER THE PAGE TO CONTINUE.
VOLTEA LA PÁGINA PARA CONTINUAR.
TOURNEZ LA PAGE POUR CONTINUER.
VIRE A PÁGINA PARA CONTINUAR.

4

TO PLAY (CONT'D.) • PARA JUGAR (CONTINUACIÓN) PLACE AU JEU (SUITE) • COMO BRINCAR (CONT.)

B ALTERNATE ROUTES • RUTAS ALTERNATIVAS • PARCOURS ALTERNATIFS • ROTAS ALTERNATIVAS

1 LAUNCH STRAIGHT THROUGH!
¡LANZA EN LÍNEA RECTA!
LANÇEZ-VOUS DIRECTEMENT!
LANÇAMENTO RETO!

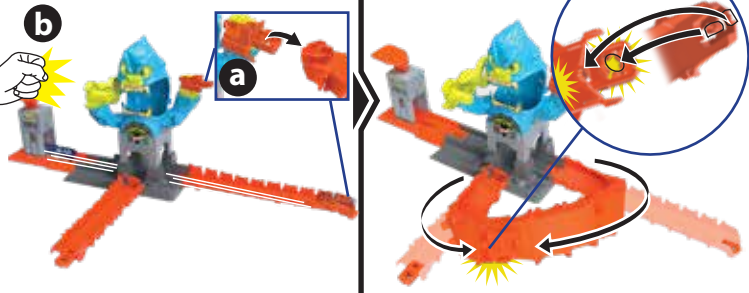

2 SNAP BOTH TRACKS.
ENCAJA AMBAS PISTAS.
EMBOÎTEZ LES DEUX PISTES.
ENCAIXE AS DUAS PISTAS.

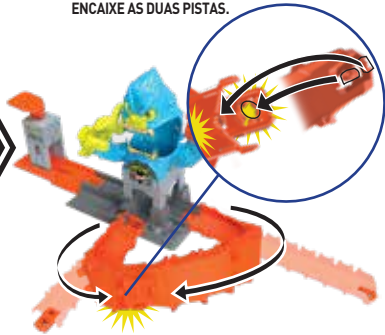

3 LAUNCH THROUGH THE CURVE!
¡LÁNZATE POR LA CURVA!
LANÇEZ-VOUS DANS LA COURBE!
LANÇAMENTO PELA CURVA!

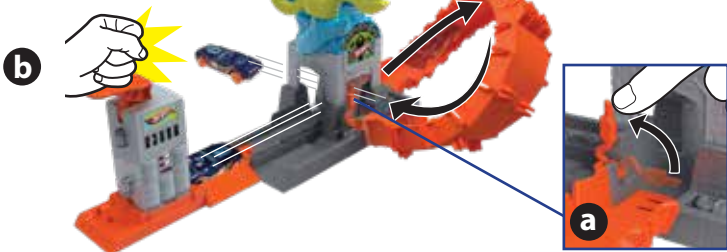

5

MORE WAYS TO PLAY • MÁS MANERAS DE JUGAR AUTRES FAÇONS DE JOUER • OUTRAS MANEIRAS DE BRINCAR

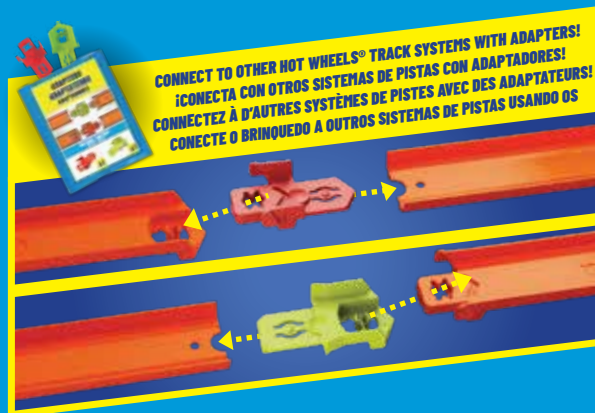

CONNECT TO OTHER HOT WHEELS® TRACK SYSTEMS WITH ADAPTERS!
¡CONECTA CON OTROS SISTEMAS DE PISTAS CON ADAPTADORES!
CONNECTEZ À D'AUTRES SYSTÈMES DE PISTES AVEC DES ADAPTEURS!
CONECTE O BRINQUEDO A OUTROS SISTEMAS DE PISTAS USANDO OS

HOT WHEELS
SPEED
SNAP
TRACK SYSTEM™

ADULTS,
FIND OUT MORE:
ADULTOS,
CONOZCAN MÁS AQUÍ:
ADULTES,
POUR EN SAVOIR PLUS :
INFORMAÇÕES AO PAIS:



ADVERTISEMENT
AVISO
PUBLICITÉ
PUBLICIDADE



JHL92

JHL74

OTHER HOT WHEELS® TRACKS AND SETS SOLD SEPARATELY.
LOS OTROS SETS Y PISTAS HOT WHEELS SE VENDEN POR SEPARADO.
AUTRES PISTES ET COFFRETS DE JEU HOT WHEELS VENDUS SEPARÉMENT.
OUTROS CONJUNTOS E PISTAS HOT WHEELS VENDIDOS SEPARADAMENTE.



©2026 Mattel. Mattel Europa B.V., Gondel 1, 1186 MJ Amstelveen, Nederland. Mattel U.K. Limited, The Porter Building, 1 Brunel Way, Slough SL1 1FQ, UK. Mattel Barbie (Shanghai), Trading Co., Ltd. Room 2005, 20th Floor, 899 Ruining Road, Xuhui District, Shanghai, 200232, PRC. Customer Care Line: 400-819-8658. Kids Kingdom Limited, Room 1908-9, Gala Place, 56 Dundas Street, Mongkok, Kowloon, Hong Kong, P.R.C. Customer Care Line: (852)2782-0766. CHICKABIDDY CO., LTD, F5, No. 186, Sec 4, Nanjing E. Rd, Taipei 10595, Taiwan region. Customer Care Line: 0800 001 256. Diimport & Diedarkan Oleh: Mattel Continental Asia Sdn Bhd, Level 19, Tower 3, Avenue 7, No. 8 Jalan Kerinchi, Bangsar South, 59200 Kuala Lumpur, Malaysia. Mattel South Africa (PTY) LTD, Office 102 B, 30 Melrose Boulevard, Johannesburg 2196. Mattel Australia Pty. Ltd., 658 Church St., Richmond, Victoria, 3121. Consumer Advisory Service - 1300 135 312. 16-18 William Pickering Drive, Albany 1331, Auckland. Mattel, Inc., 636 Girard Avenue, East Aurora, NY 14052, U.S.A. Mattel Canada Inc., Mississauga, Ontario L5R 3W2. Consumer Services/Service à la clientèle: 1-800-524-8697 and/et 1-800-432-5437 for Fisher Price products/pour les produits Fisher Price. Importado y distribuido por Mattel de México, S.A. de C.V., Miguel de Cervantes Saavedra No. 193, Pisos 10 y 11, Col. Granada, Alcaaldia Miguel Hidalgo, C.P. 11520, México, Ciudad de México. R.F.C. MME-920701-NB3. Tels.: 59-05-51-00 Ext. 5206 ó 01-800-463-59-89. Mattel Chile S.A., Pdte. Riesco 5561, Of. 203-204 PS2, Las Condes, Santiago. Servicio al consumidor Venezuela: Tel.: 0-800-100-9123. Mattel Argentina, S.A., Av. Libertador 1000, Piso 11 – Oficinas 109 y 111, Vicente López – Prov. Buenos Aires. Tel.: 0800-666-3373. Mattel Colombia, S.A., Calle 123#7-07 P.5, Bogotá. Mattel Perú, S.A., Av. Juan de Arona # 151, Centro Empresarial Juan de Arona, Torre C, Piso 7, Oficina 704, San Isidro, Lima 27, Perú. RUC: 20425853865. Reg. Importador: 02350-12-JUE-DIGESA. Tel.: 0800-54744. E-mail Latinoamérica: servicio.dientes@mattel.com. Distribuido por: Mattel do Brasil Ltda. - CNPJ: 54.558.002/0001-20 - Av. Dr. Chucri Zaidan, 296 - 15º. Andar - 04583-110 - Vila Cordeiro - São Paulo - SP - Brasil. Serviço de Atendimento ao Consumidor: Contato: <https://faleconosco.mattel.com.br/Contato>. Email: sac.matteldobrazil@mattel.com.



ASST.HDR29
JHL92-4B70
1103590621-4LB

? service.mattel.com