



HOT WHEELS

Supra



JKG40 - '94 TOYOTA SUPRA MKIV

'94 TOYOTA SUPRA MKIV

The '94 Toyota Supra MKIV is a cult icon of the racing and modification scene – and with good reason. Powered by the 2JZ 3.0L inline-6 engine and built with lightweight materials to maximize speed, this is a car built to dominate. The race car version of the MKIV has competed extensively, from Le Mans to the All-Japan GT Championships. Made famous on the big screen, the Supra MKIV has become a symbol of car culture.

La Toyota Supra MKIV de 1994 est une véritable légende pour les amateurs de course automobile et de tuning, et cela ne doit rien au hasard. Propulsé par le moteur 2JZ 3,0 L six cylindres en ligne et conçu avec des matériaux légers pour maximiser la vitesse, ce bolide est taillé pour la victoire. La MKIV a largement fait ses preuves en compétition, du Mans aux championnats All-Japan GT. Rendue célèbre par le cinéma, la Supra MKIV est devenue un symbole de la culture automobile.

1993

The Toyota Supra MKIV ('mark four') is unveiled at the Chicago Motor Show. Designed by Isao Tsuzuki, it had been in development for four years. It was followed up by the 1994 model, featuring larger wheels and brakes.

La Toyota Supra MKIV (« Mark four ») a été dévoilée au Chicago Motor Show. Conçue par Isao Tsuzuki, elle était en développement depuis quatre ans. Il a été suivi par le modèle de 1994, doté de roues et de freins plus grands.

El Toyota Supra MKIV ("Mark Four") se presentó en el Salón del Automóvil de Chicago. Su diseñador, Isao Tsuzuki, dedicó cuatro años a desarrollarlo. Fue seguido por el modelo de 1994, que presentaba ruedas y frenos más grandes.

Der Toyota Supra MKIV („Mark Four“) wird auf der Chicago Motor Show vorgestellt. Entworfen von Isao Tsuzuki, befand sich der Supra vier Jahre lang in der Entwicklung. Es folgte das Modell von 1994, das größere Räder und Bremsen hatte.



2013

Hot Wheels® releases the 1:64 scale '94 Toyota Supra MKIV as part of its HW: Street Power series.

Hot Wheels lance la Toyota Supra MKIV 1994 à l'échelle 1:64, dans le cadre de la série HW: Street Power.

Ahora, Hot Wheels lanza el Toyota Supra MKIV de 1994 a escala 1:64 como parte de su colección HW: Street Power.

Hot Wheels veröffentlicht den '94 Toyota Supra MKIV im Maßstab 1:64 im Rahmen der HW: Street Power Serie.



El Toyota Supra MKIV de 1994 es un modelo de culto en el mundo de las carreras y el tuneo, y con razón. Este coche, con su motor 2JZ de 3,0 L de seis cilindros en línea y su fabricación con materiales ligeros para maximizar la velocidad, está diseñado para liderar. El MKIV ha competido en numerosas ocasiones, desde Le Mans hasta All-Japan GT Championships. El Supra MKIV, cuya fama procede de la gran pantalla, se ha convertido en todo un símbolo de la cultura del automóvil.

Der '94 Toyota Supra MKIV ist eine Kultikone der Renn- und Tuningszene – und das aus gutem Grund. Angetrieben von einem 2JZ 3,0-Liter 6-Zylinder-Motor und gefertigt aus leichten Materialien, um die Geschwindigkeit zu maximieren – ein dominantes Auto. Der MKIV hat an zahlreichen Rennen teilgenommen: von Le Mans bis zu den All-Japan GT Championships. Durch seine Auftritte auf der großen Leinwand wurde der Toyota Supra MKIV zu einer echten Ikone der Autokultur.

2026

The buildable '94 Toyota Supra MKIV is here in an exclusive black model, complete with carbon fiber-like detailing and functional steering.

La Toyota Supra MKIV de 1994 à construire est ici présentée dans un modèle noir exclusif, avec des détails en style fibre de carbone et une direction fonctionnelle.

El Toyota Supra MKIV de 1994 construible llega en un exclusivo modelo negro, con detalles de fibra de carbono y una dirección funcional.

Der Toyota Supra MKIV aus dem Jahr 1994 kann jetzt nachgebaut werden. Er ist in einem exklusiven schwarzen Modell erhältlich, komplett mit Carbonfaser-Details und funktionsfähiger Lenkung.





Build your dream car with the Hot Wheels Elite Series™. Each car in this series is an homage to a classic piece of racing history and a nod to car culture. Display your vehicle in its original format or customize it with decals and special parts.

REMIX YOUR RIDE.

DISPLAY IT WITH PRIDE.

Construisez la voiture de vos rêves avec la Hot Wheels Elite Series™. Chaque voiture de cette série fait référence à la culture automobile et rend hommage à un modèle de course emblématique. Exposez votre véhicule dans son format d'origine ou personnalisez-le avec des autocollants et des pièces spéciales.

RÉINVENTEZ VOTRE VOITURE.

EXPOSEZ-LA AVEC FIERTÉ.

Construye el coche de tus sueños con la Hot Wheels Elite Series™.

Cada coche de esta serie es un homenaje a un clásico de la historia de las carreras y un guiño a la cultura del automóvil. Expón tu vehículo en su formato original o personalízalo con pegatinas y piezas especiales.

REMODELA TU COCHE.

EXPONLO CON ORGULLO.

Mit der Hot Wheels Elite Series™ können alle ihr Traumauto nachbauen. Jedes Auto in dieser Serie ist eine Hommage an einen Klassiker der Rennhistorie und an die Autokultur. Das Auto kann in der Originalversion ausgestellt oder mit Aufklebern und Zusatzteilen individuell gestaltet werden.

INDIVIDUELL GESTALTET.

MIT STOLZ PRÄSENTIERT.



CUSTOMIZE YOUR CAR

PERSONNALISEZ VOTRE VOITURE

PERSONALIZA TU COCHE / DAS AUTO INDIVIDUELL GESTALTEN



154



Most models can be built one at a time. / La plupart des modèles peuvent être construits un à la fois. / La mayoría de modelos se pueden construir de uno en uno. / A maioria dos modelos pode ser construída separadamente. / La maggior parte dei modelli possono essere realizzati uno per volta. / Die meisten Modelle können eines nach dem anderen gebaut werden. / Większość modeli nie da się budować jednocześnie z innymi. / De meeste modellen kunnen één voor één gebouwd worden. / Большинство моделей могут быть собраны по одной за раз. / De fleste modeller kan bygges enkeltvis. / De fleste modeller kan byggas en i taget. / De fleste modellene kan bygges en om gangen. / Useimmat mallit voidaan rakentaa yksi kerrallaan. / Majoritatea modelelor pot fi construite unul câte unul. / Τα περισσότερα μοντέλα μπορούν να κατασκευασθούν ένα ένα. / Modellerin sağı ayni anda edilmeyi gerektirebilir. / Většinou lze najednou sestavit pouze jeden model. / Väčšina modelov môže byť zostavená iba raz. / A modellek többségéből egyszerre csak egy építhető. / Більшість моделей можна збирати по одній. / ほとんどのモデルは、一度に一つを組み立てることができます。 / 大多数型号可一次性建构。

يمكن تركيب التصاميم الواحد تلو الآخر.

THE MINDS **BEHIND THE WHEEL**

LES CONCEPTEURS **DERRIÈRE LE VOLANT**

LAS MENTES DETRÁS DEL VOLANTE / DIE KREATIVEN KÖPFE HINTER DEM KONZEPT



TRISTAN BRUNEAU

The '94 Toyota Supra is incredibly prevalent in pop culture, so it was an honor to design it as our first Toyota set from Mattel Brick Shop™. 40 custom pieces were designed to accurately recreate its round shape. The carbon fiber style finish is the piece de resistance on this build, adding interesting depth to the all-black design. To match the Hot Wheels® die-cast car, we included a flat spoiler and skirt as customization options.

La Toyota Supra 1994 est extrêmement présente dans la pop culture. C'était donc pour nous un honneur de travailler sur ce modèle pour notre premier coffret Toyota Mattel Brick Shop™. 40 pièces personnalisées ont été conçues pour recréer avec précision sa forme toute en courbe. La finition en style fibre de carbone est la pièce maîtresse de cette construction, ajoutant une profondeur intéressante à ce modèle entièrement noir. Pour correspondre à la voiture Hot Wheels®, nous avons inclus un spoiler plat et un bas de caisse comme options de personnalisation.

El Toyota Supra de 1994 tiene una increíble prevalencia en la cultura pop, por lo que ha sido un honor diseñarlo para nuestro primer conjunto de Toyota para Mattel Brick Shop™. Hemos diseñado 40 piezas personalizadas para recrear su forma redondeada con precisión. El acabado de fibra de carbono es la pieza clave de esta construcción, puesto que añade una interesante textura al diseño totalmente negro. Para que combine con el coche metálico de Hot Wheels®, hemos incluido un alerón plano y un faldón como opciones de personalización.

Der '94 Toyota Supra ist in der Popkultur unglaublich präsent, daher war es eine Ehre, ihn als unser erstes Toyota-Set von Mattel Brick Shop™ zu entwerfen. Es wurden 40 individuelle Teile entworfen, um die runde Form authentisch nachzubilden. Die Carbonfaser-Oberfläche ist das Highlight dieses Modells und verleiht dem komplett schwarzen Design eine interessante Tiefe. Passend zum Hot Wheels® Die-Cast-Auto bieten wir einen flachen Spoiler und eine Schürze zur individuellen Gestaltung.



JIMMY LIU

One of the 90's JDM titans, this iconic Japanese sports car always had a presence on the streets and is one of the most influential cars in JDM car culture. The legendary 2JZ 6 cylinder engine was easily tunable and reliably put some serious power to the ground. As a dream car for myself and many others, our Hot Wheels® version features custom aero with a proper stance to really live up to its highway missile reputation!

Cette voiture de sport japonaise emblématique, qui compte parmi les légendes JDM des années 1990, a toujours été présente sur les routes et reste l'un des modèles qui auront le plus marqué la culture automobile JDM. Le légendaire moteur 2JZ 6 cylindres était facilement modifiable et transmettait une puissance impressionnante aux roues avec une fiabilité remarquable. Pour rester fidèle à cette voiture qui compte de nombreux fans (dont je fais partie), notre version Hot Wheels® est dotée d'un aérodynamisme personnalisé et d'une allure inimitable : de quoi faire honneur à sa réputation de missile automobile !

Este icónico coche deportivo japonés, además de ser unos de los titanes del JDM en los 90, siempre ha tenido una gran presencia en las calles y es uno de los coches más influyentes de la cultura automovilística del JDM. El legendario motor 2JZ de seis cilindros se adaptaba con facilidad y aportaba una potencia muy considerable. Este coche es un sueño tanto para mí como para muchas otras personas, y nuestra versión Hot Wheels® tiene una forma aerodinámica personalizada e ideal para mantener su reputación de cohete en la carretera.

Dieser ikonische japanische Sportwagen gilt als einer der Titanen der japanischen Autokultur der 90er Jahre. Dieses Auto war stets auf den Straßen präsent und ist eines der einflussreichsten Autos der JDM-Autokultur. Der legendäre 2JZ 6-Zylinder-Motor war leicht zu tunen und brachte zuverlässig ordentlich Leistung für die Straße. Als Traumauto für mich und viele andere verfügt unsere Hot Wheels® Version über eine maßgeschneiderte Aerodynamik mit einer passenden Haltung, damit das Auto seinem Ruf als Autobahnrakete wirklich gerecht wird!



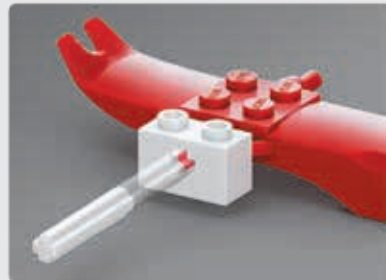

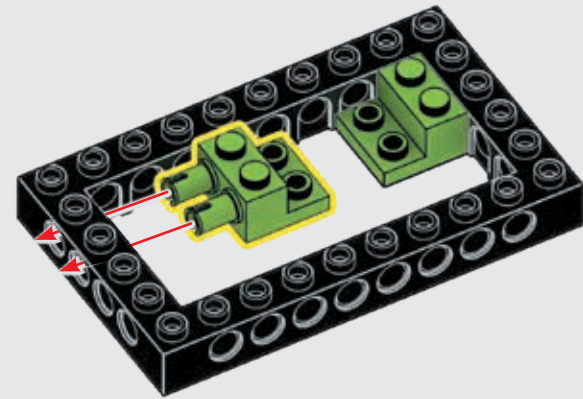
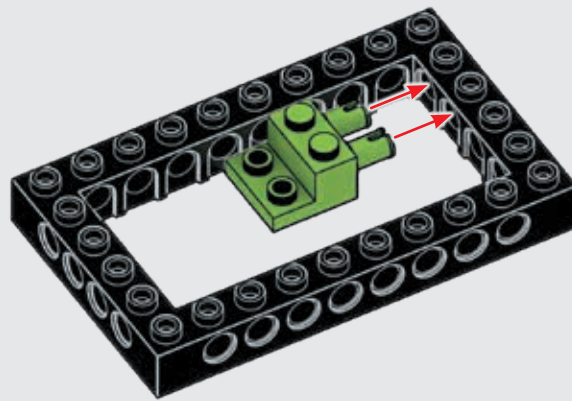
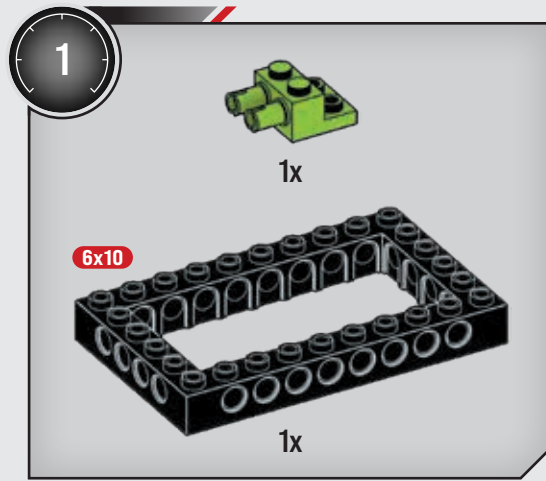

3



2x

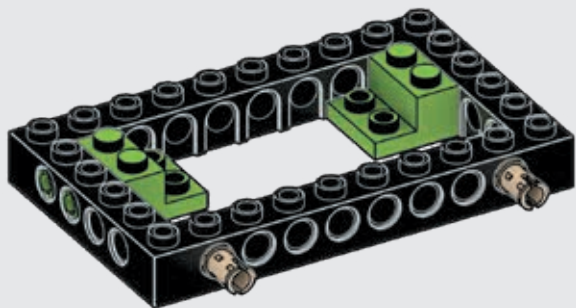
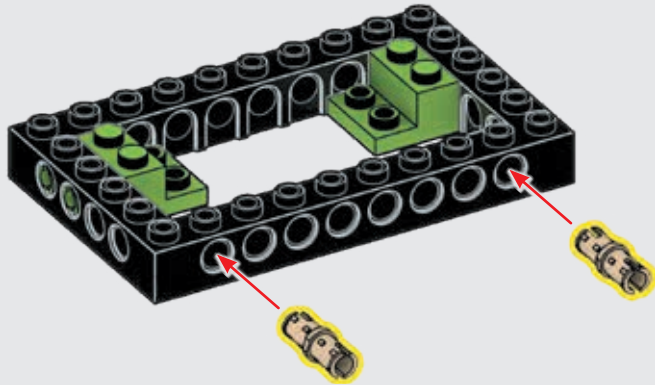

4

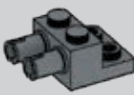

1x

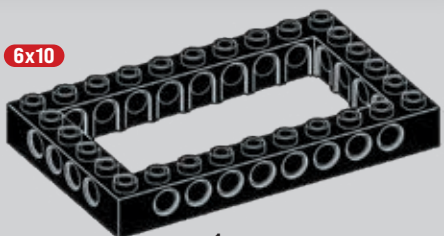

6x10

1x

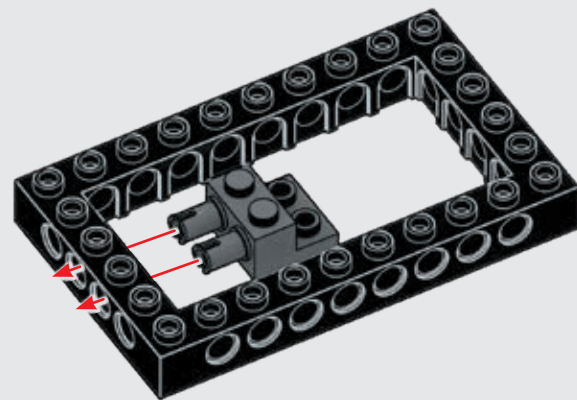

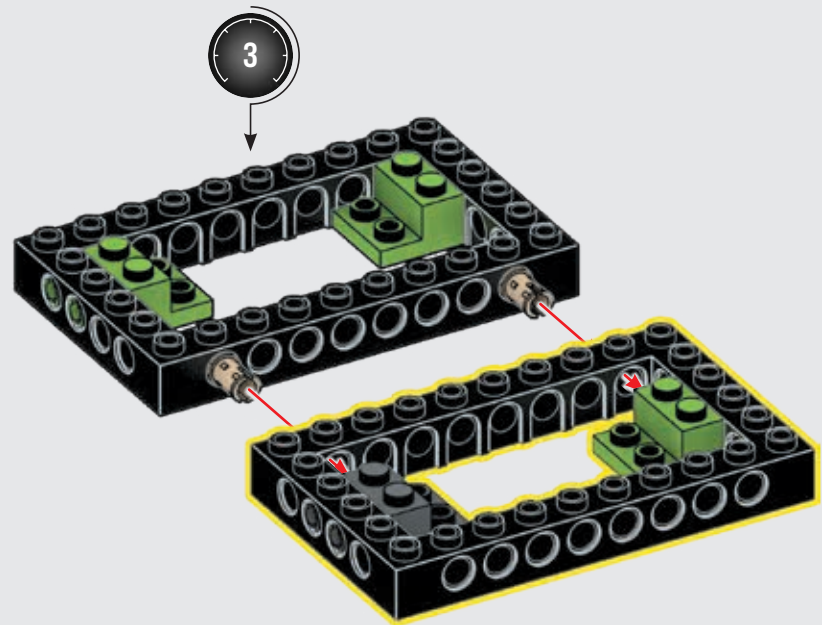
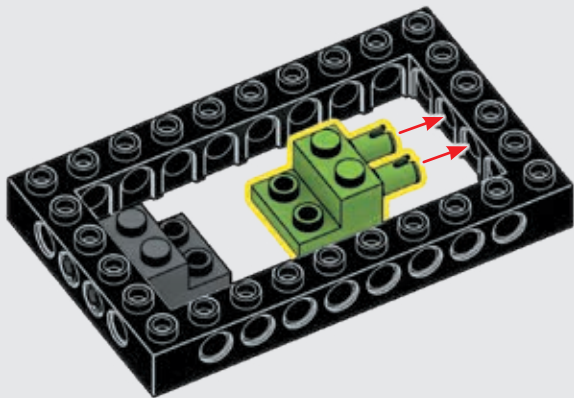
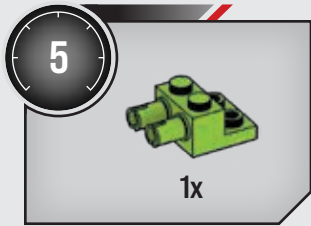

7



4x

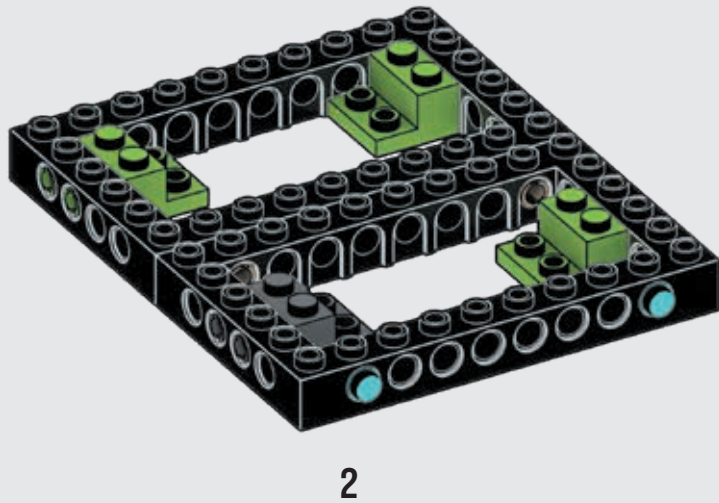
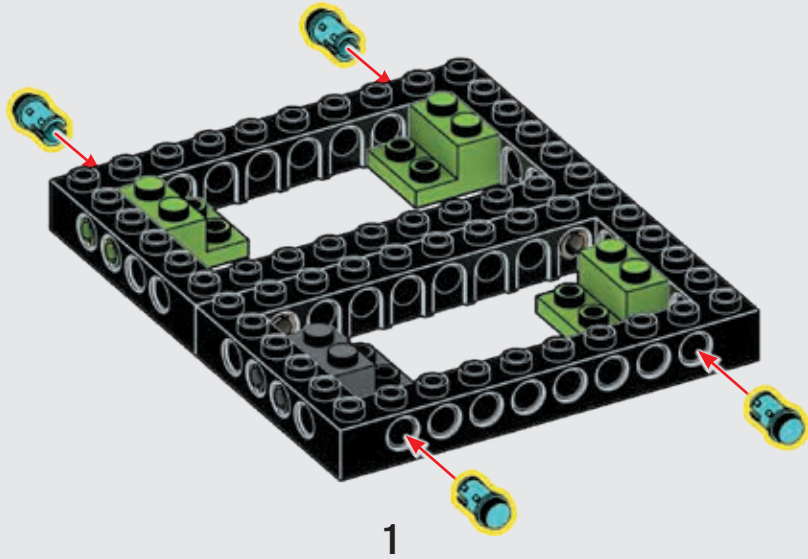

8

6x8

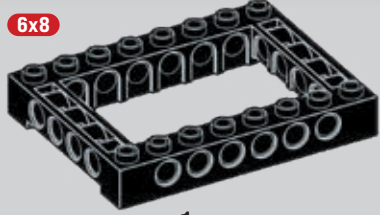

2x

1x

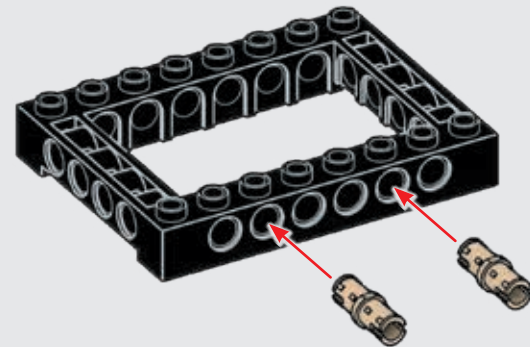

9



4x



2x



2x

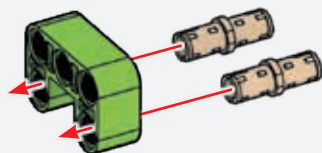

1

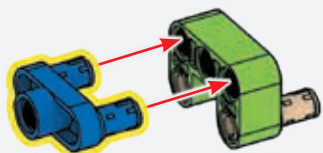

2

x2

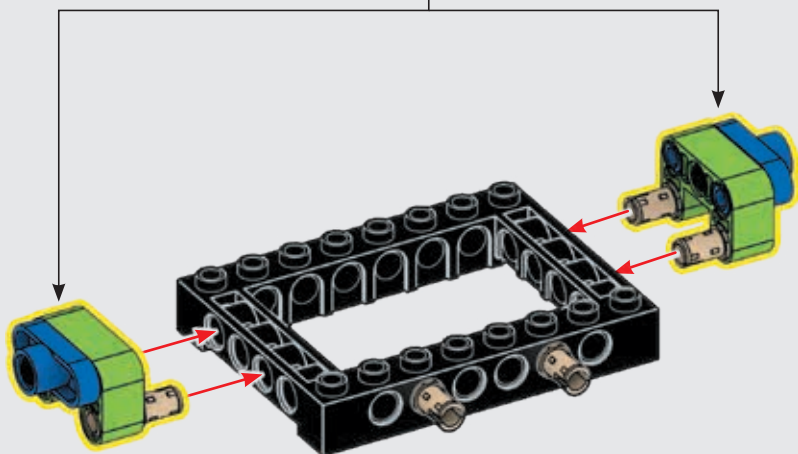

10



3x

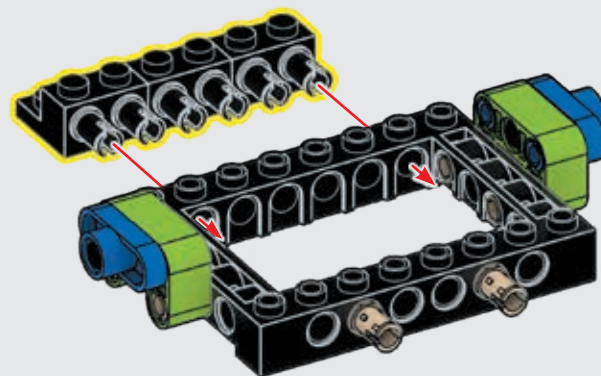

1

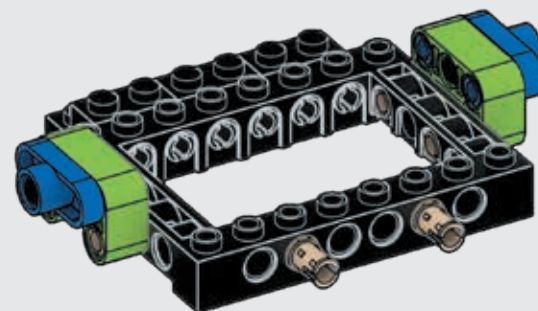

2

11

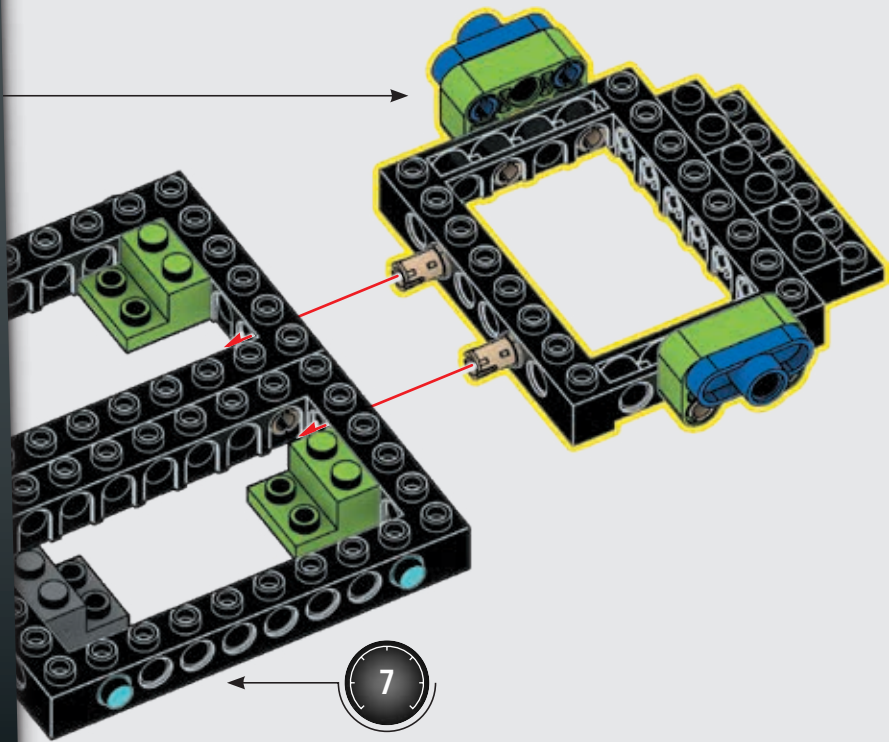

12

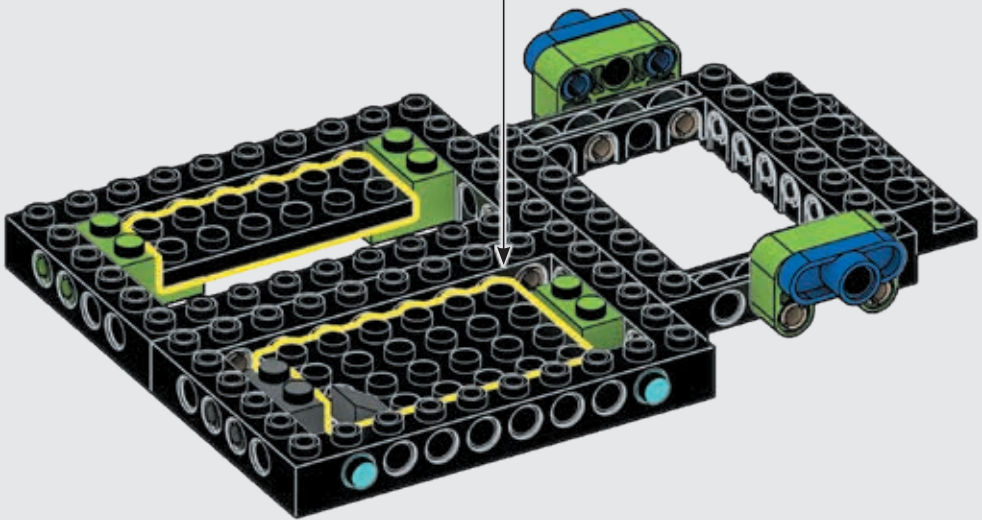
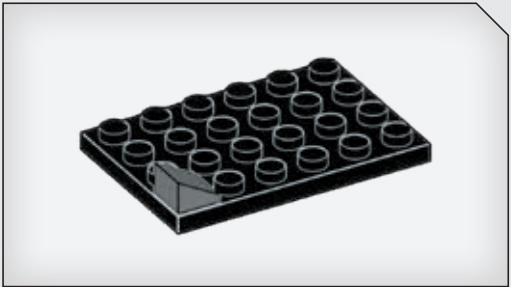

13

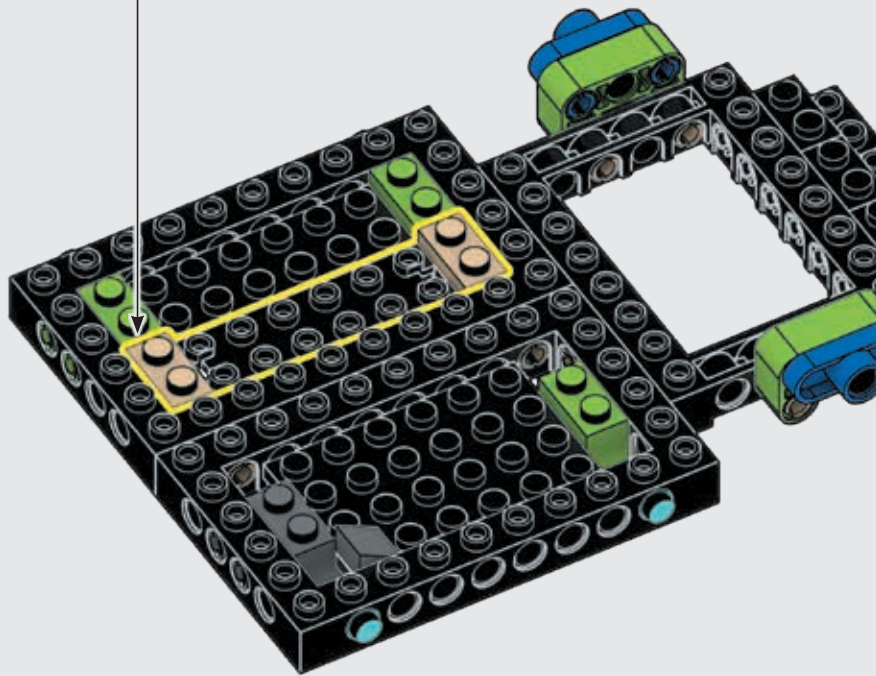
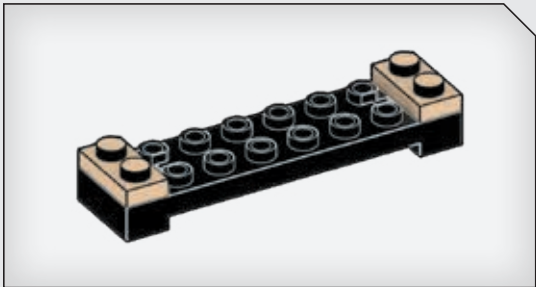

14

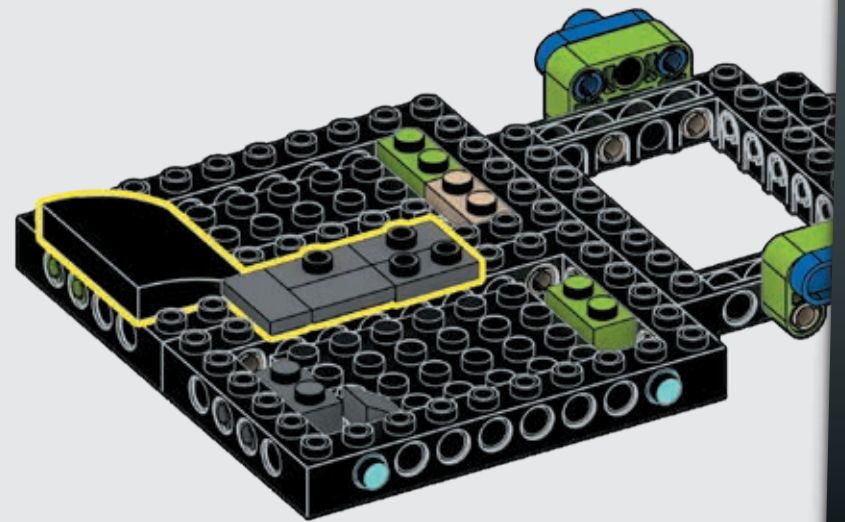
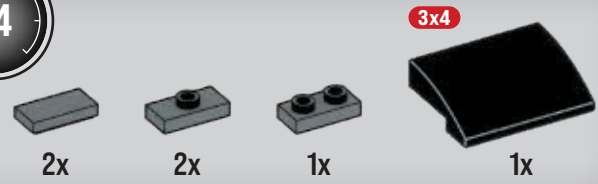

15

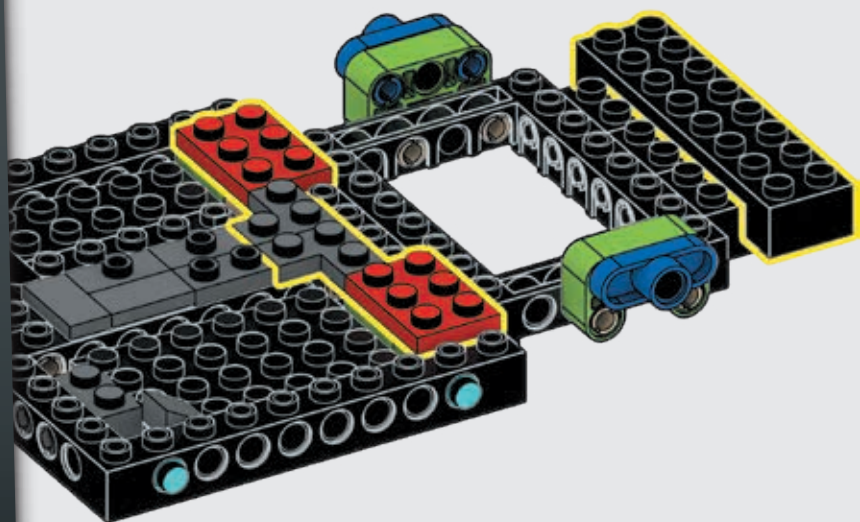
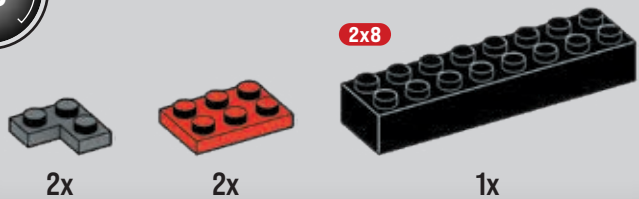

16

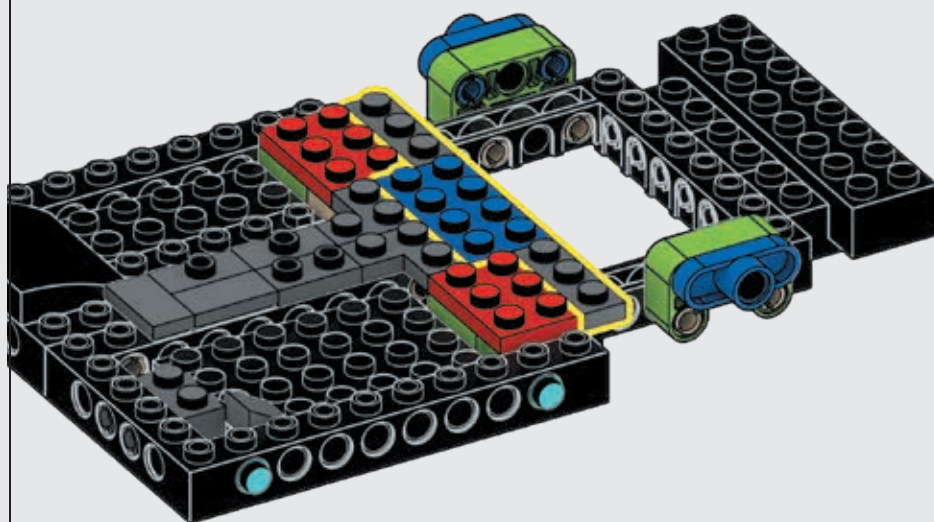
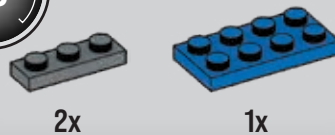

17

6x8

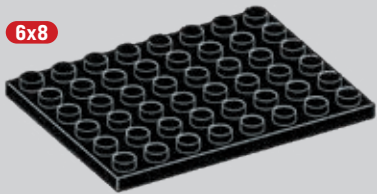

1x

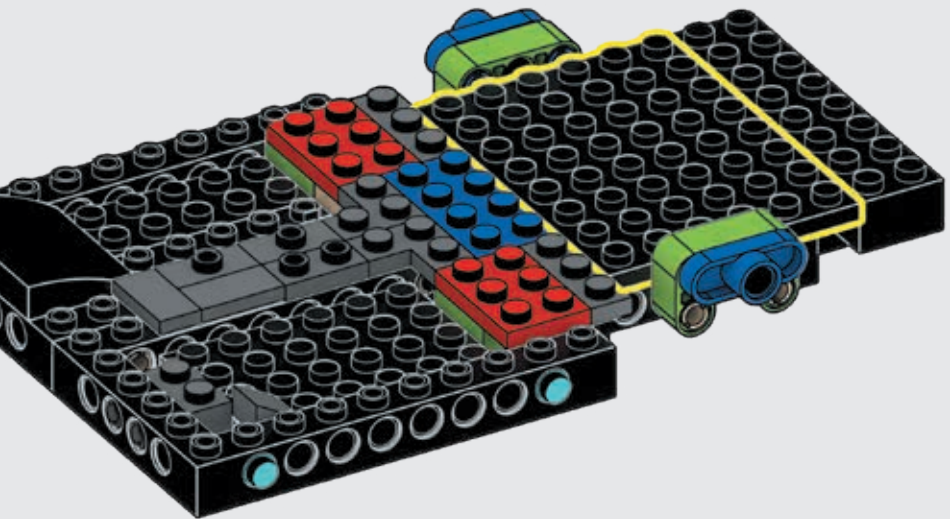

18



1x



1x



1x



1x

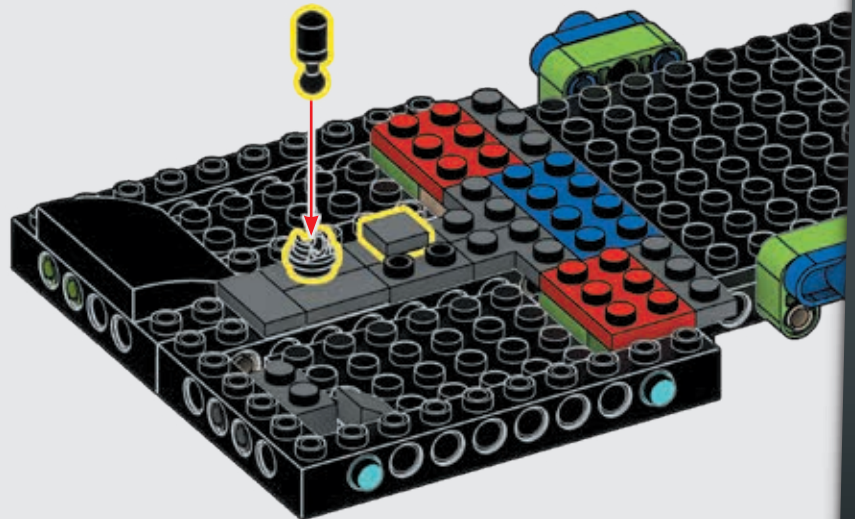
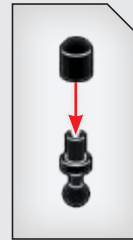

19

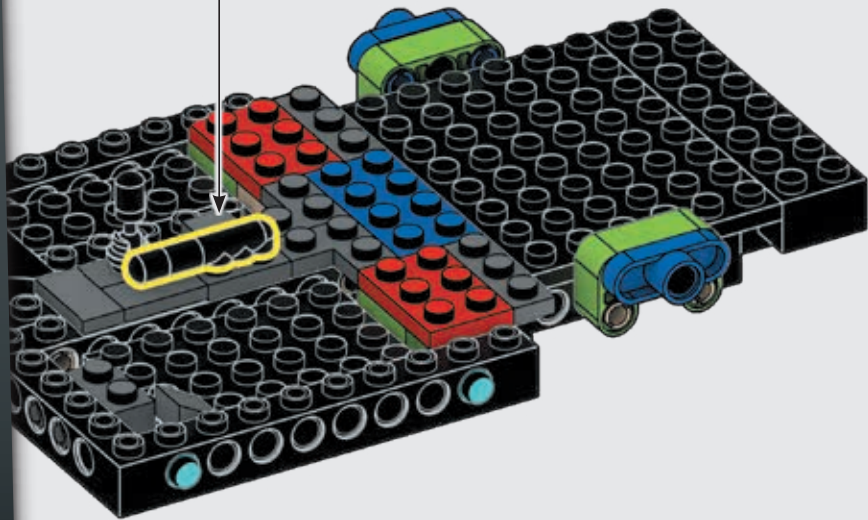
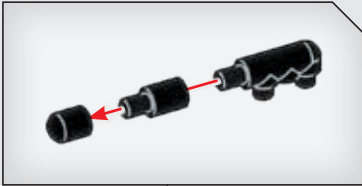

20

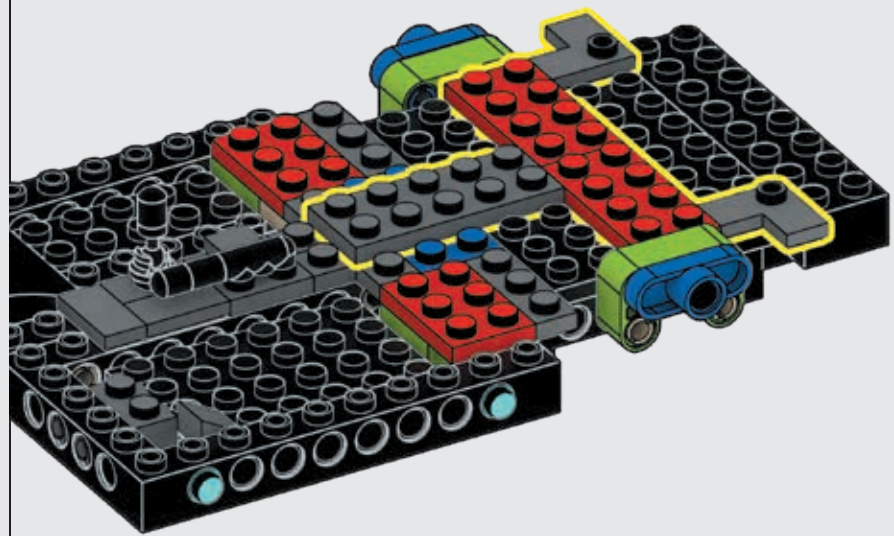
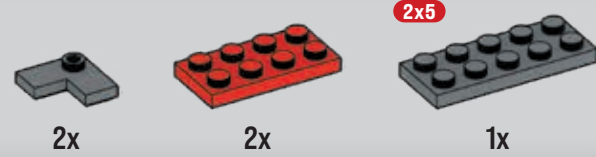

21



2x

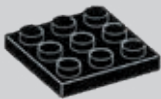

2x

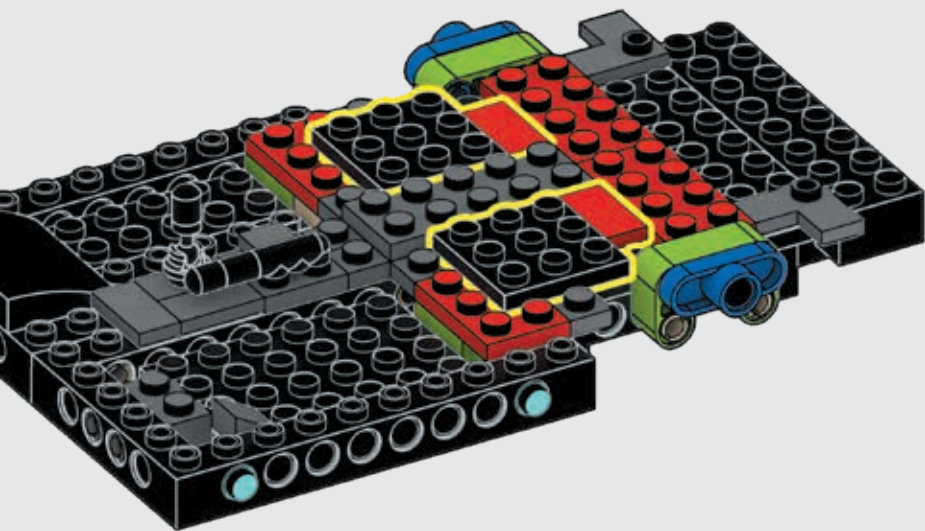

22



2x

2x3

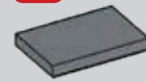

1x

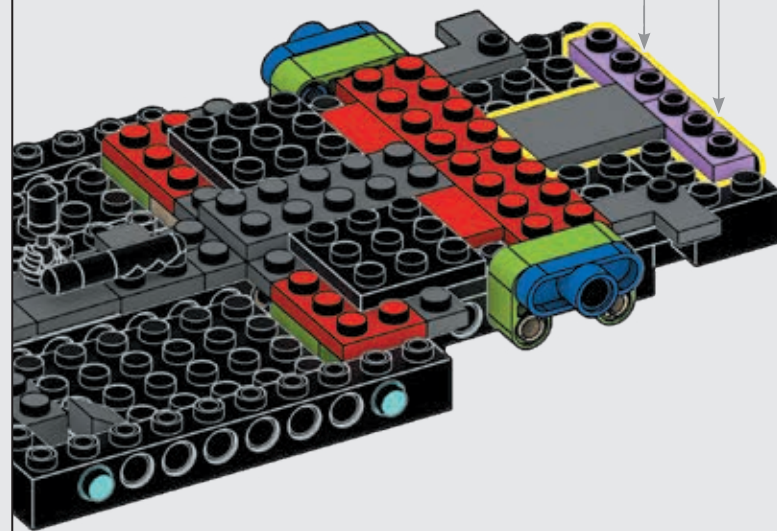

23



2x

1x3



1x

1x4



1x

1x6



1x

24



2x



2x

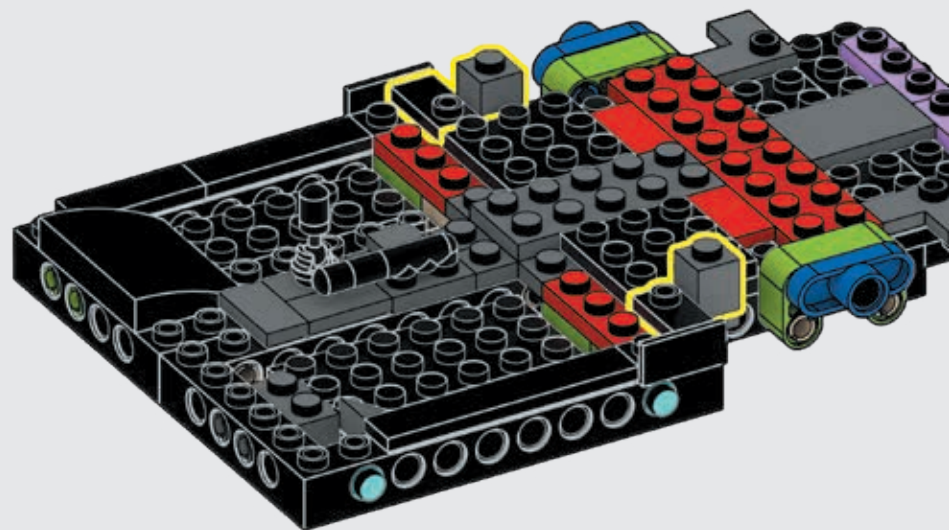
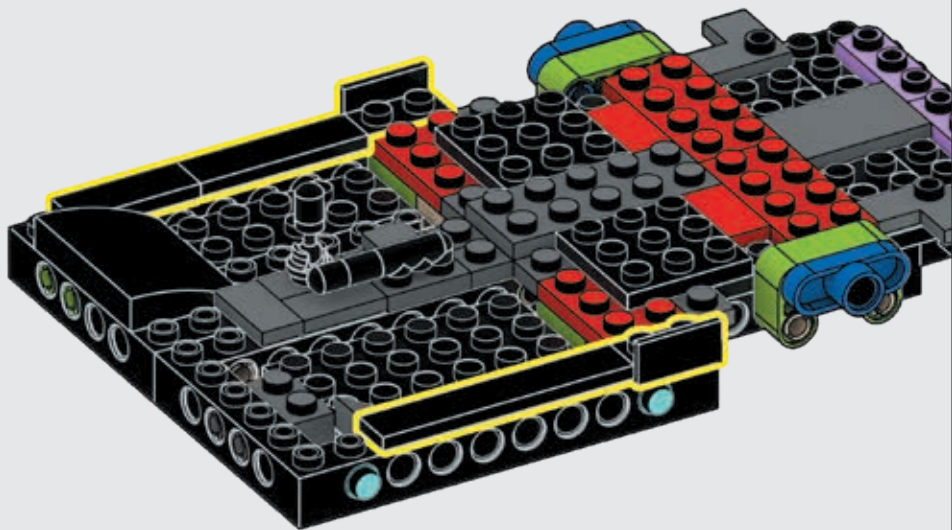

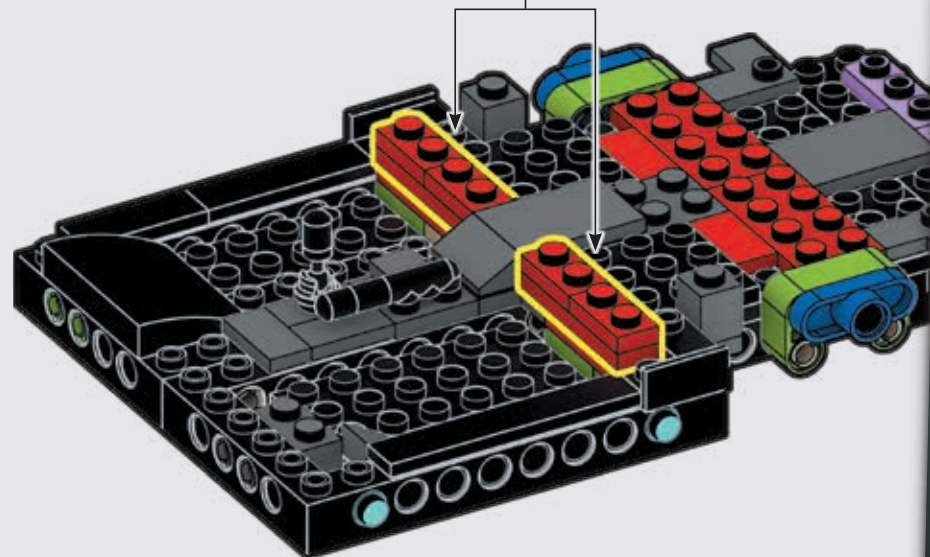
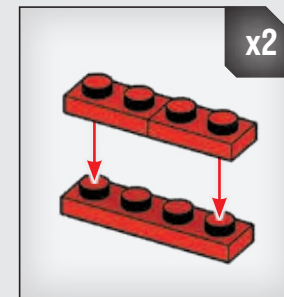
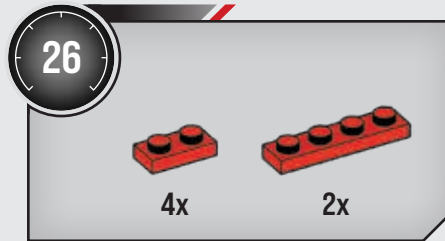
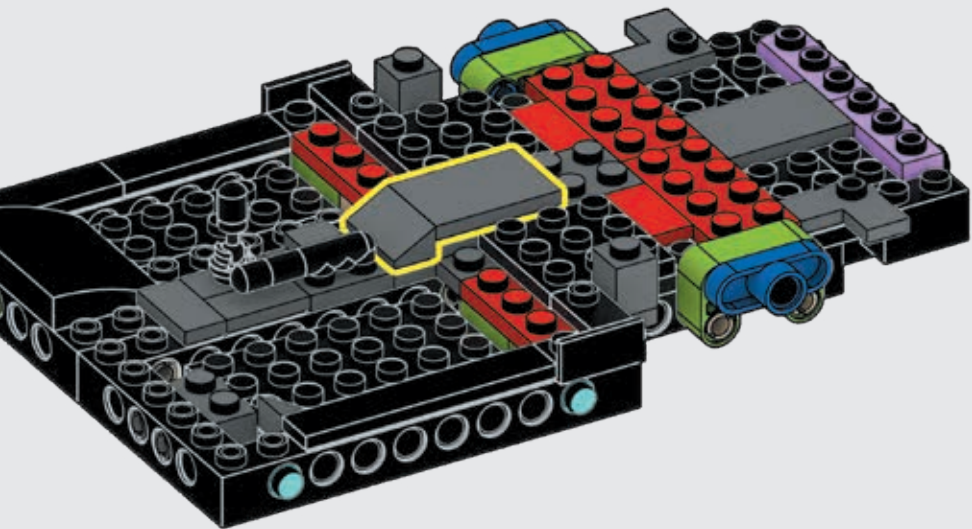
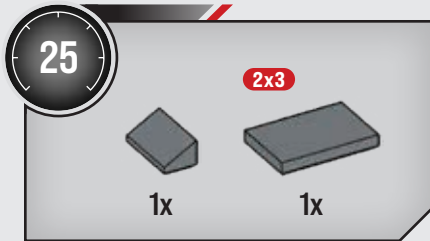

27

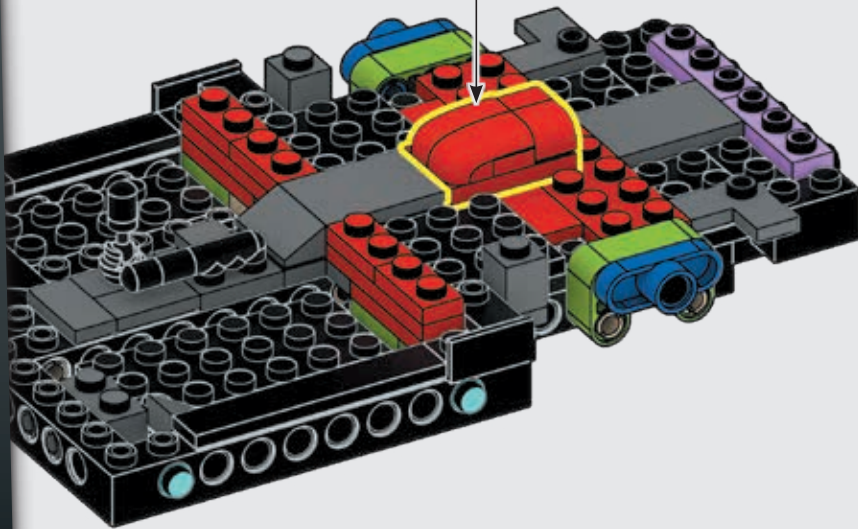
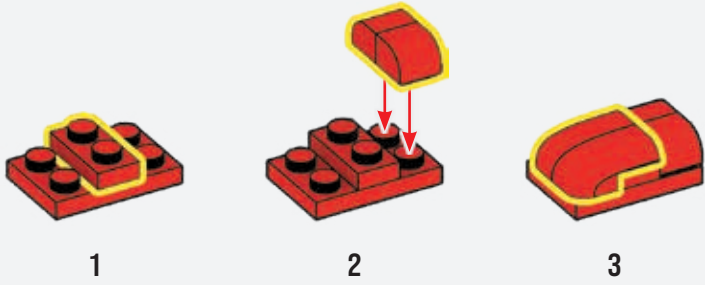
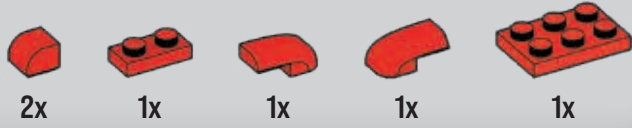

28

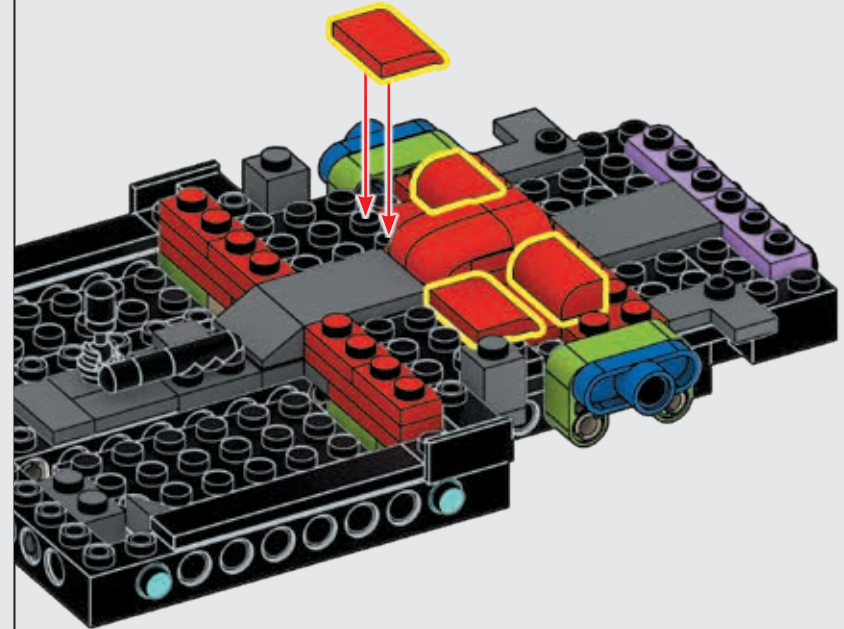
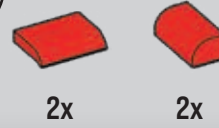

29

- 2x 
- 2x 
- 1x 
- 1x 
- 2x 

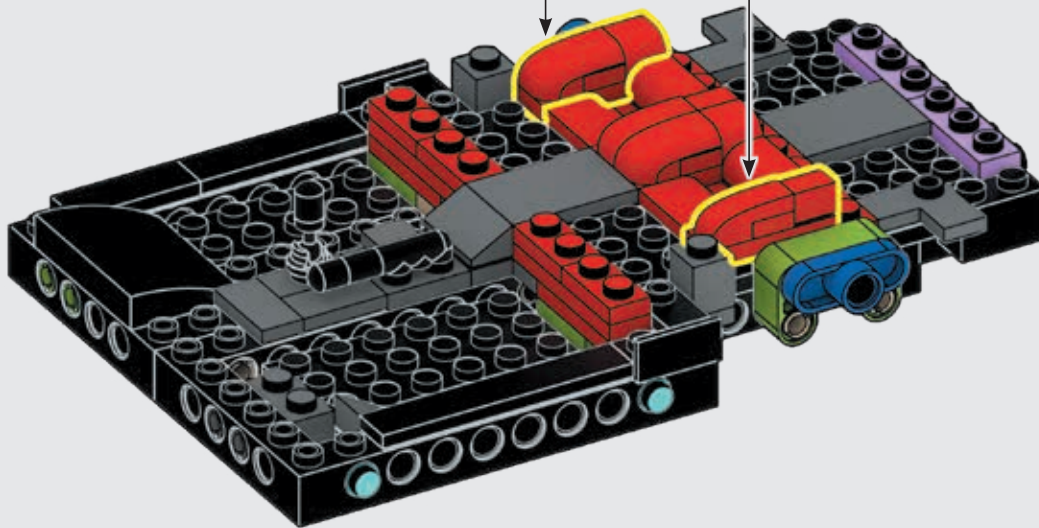
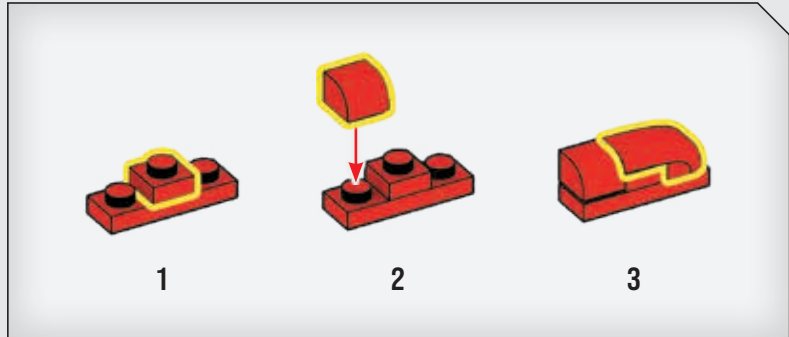
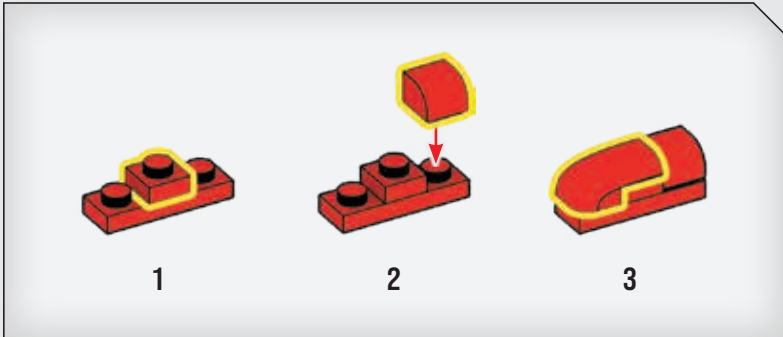

30

8x8

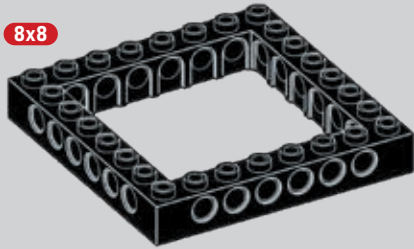

1x

1x

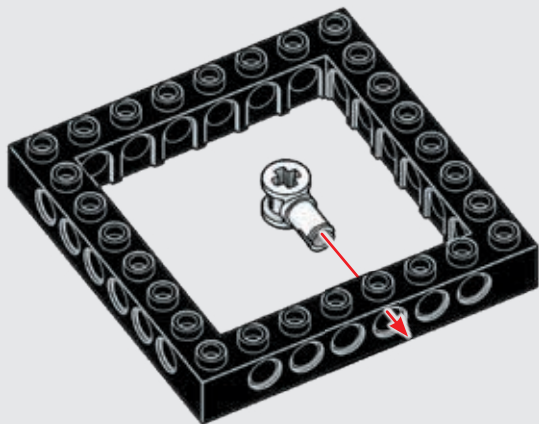

31



1x

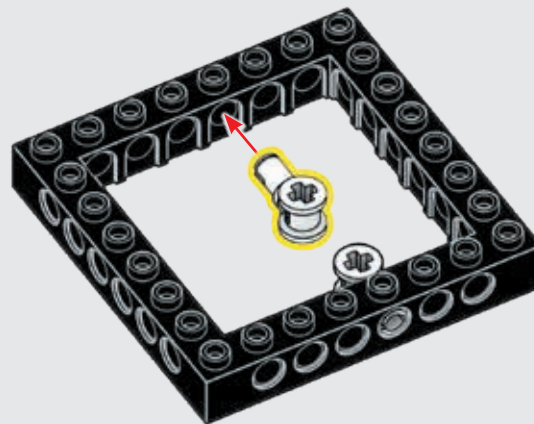

32

2x

1x

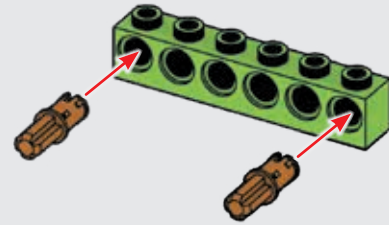

1

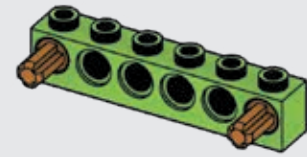

2

33

1x

1x

1x

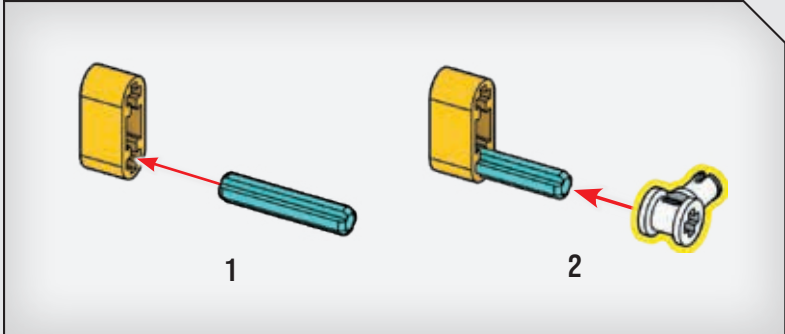

1

2

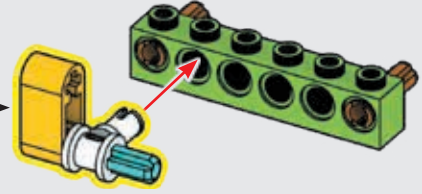

1

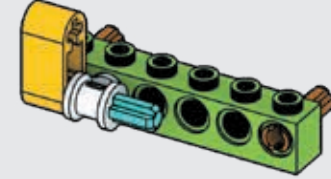

2

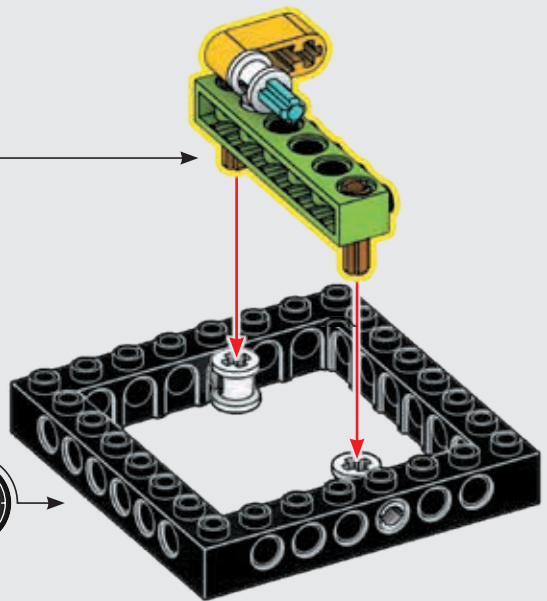

1

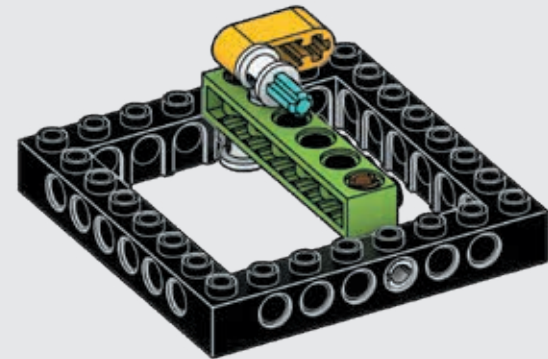

2

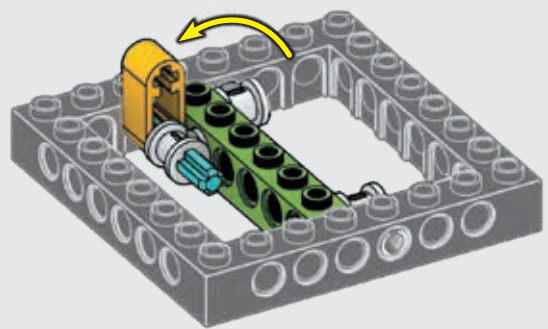

3

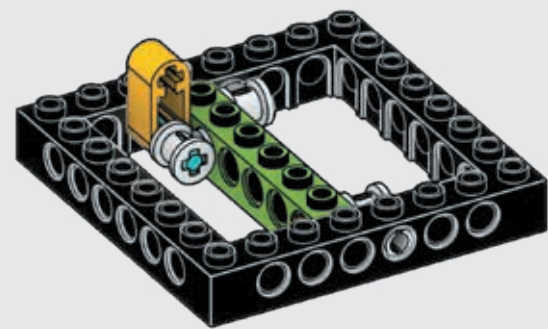
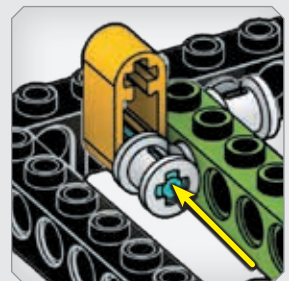

4

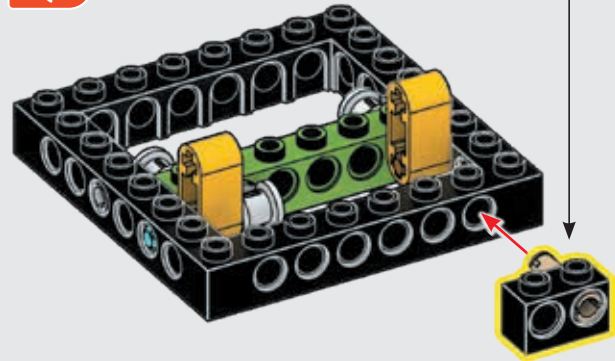
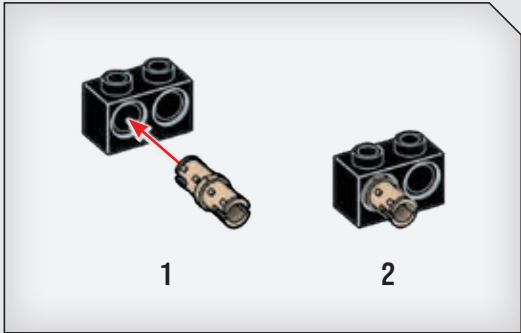
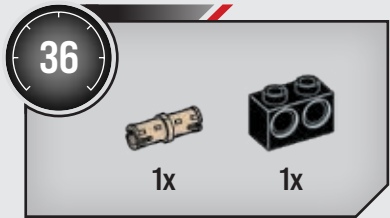
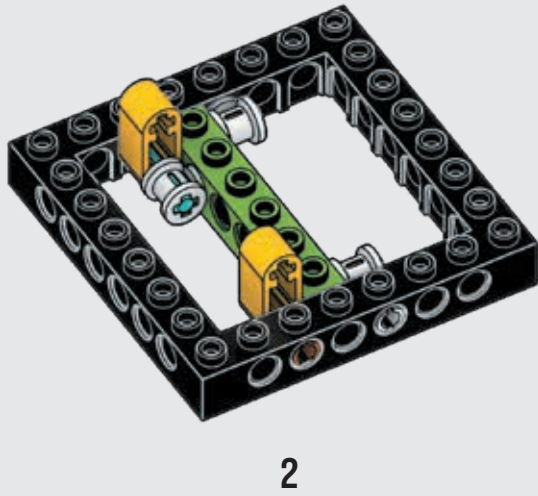
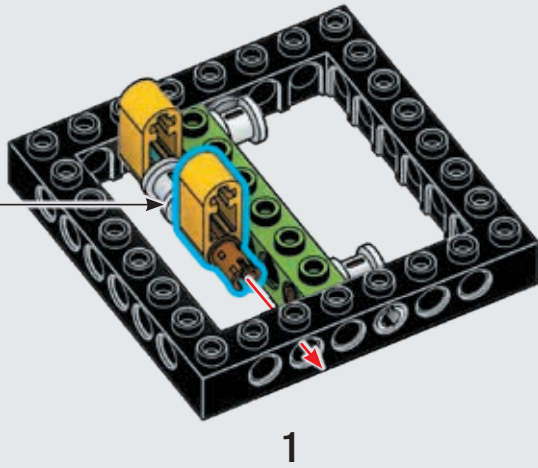
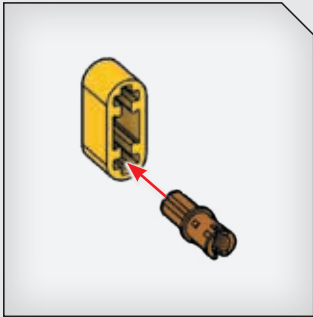
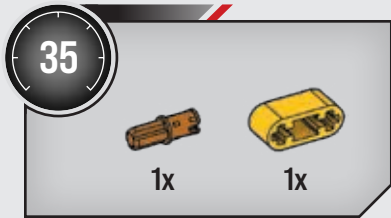

37

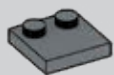

1x



1x

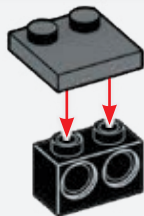

1



2

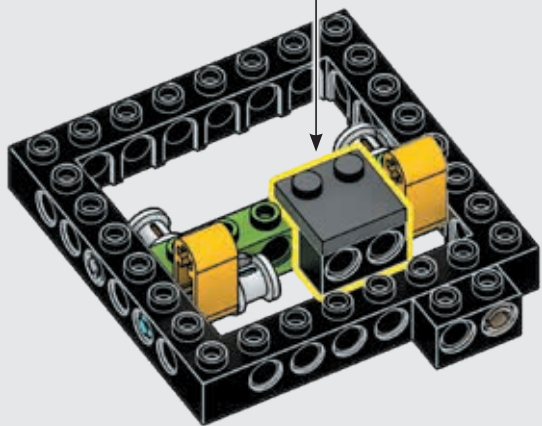

38



1x

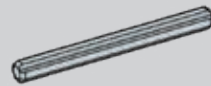

1x

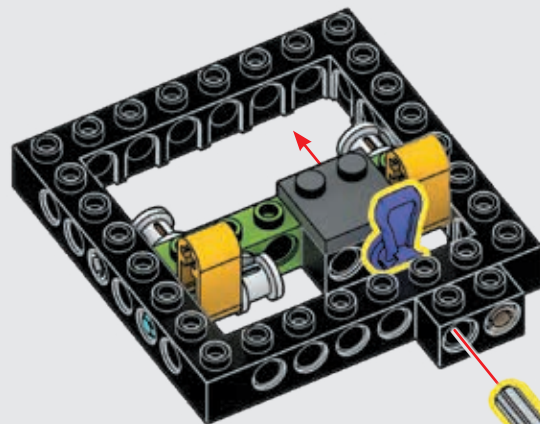

1

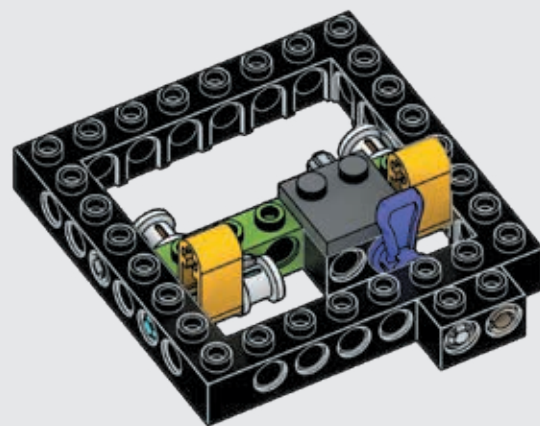

2

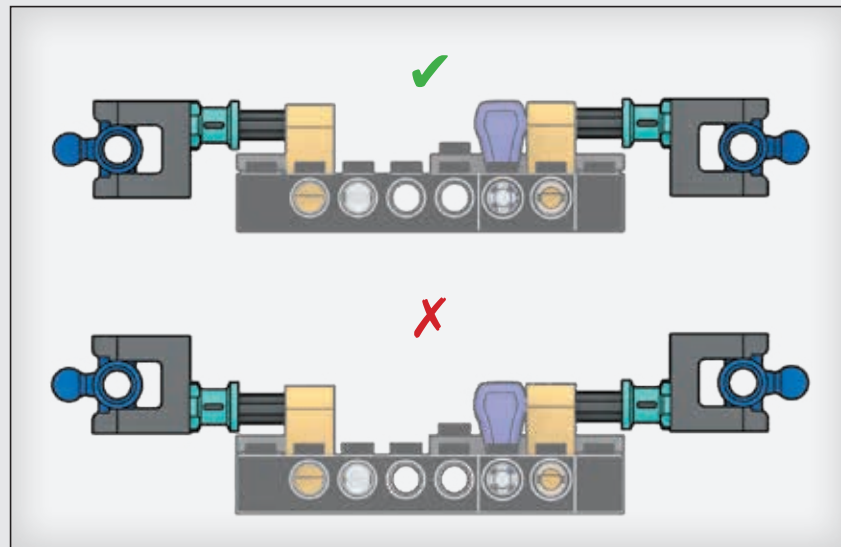
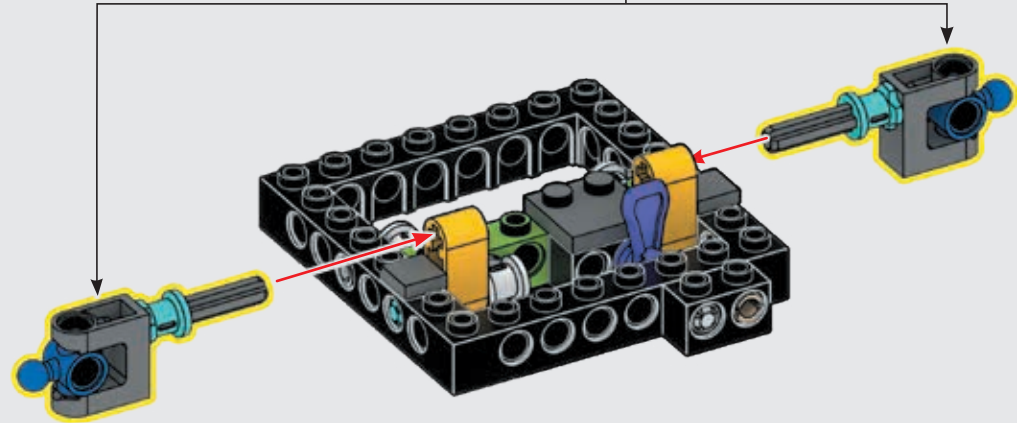
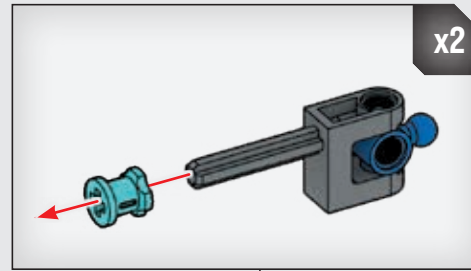
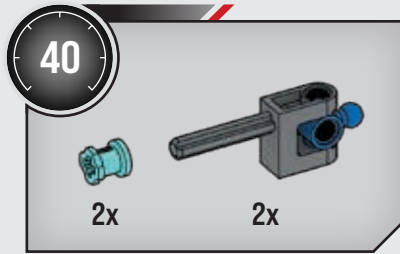
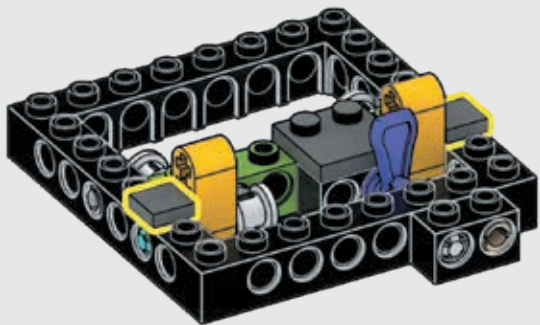
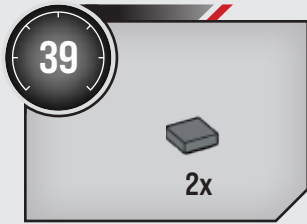

41

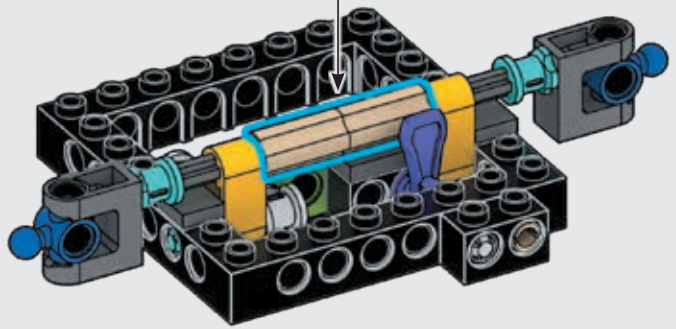
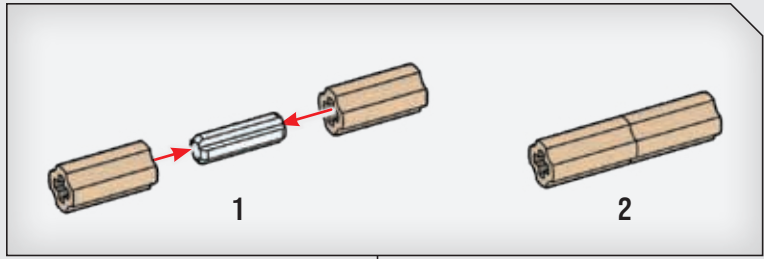

1

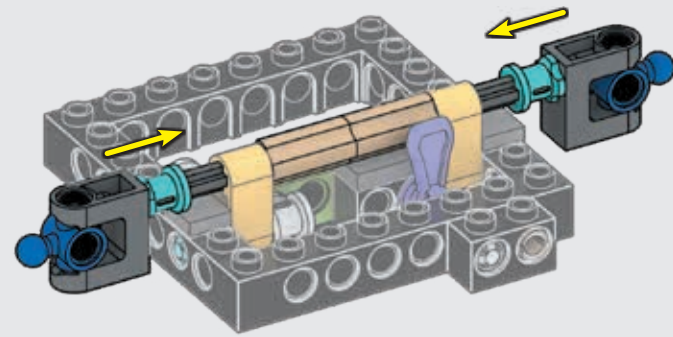

2

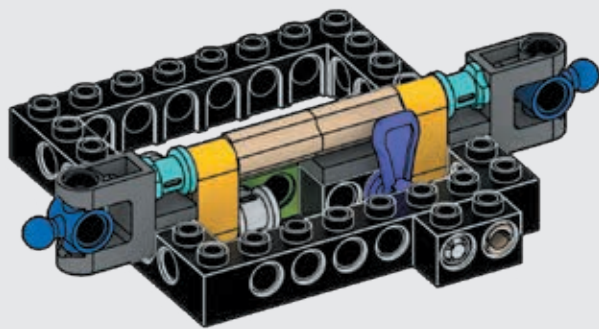

3

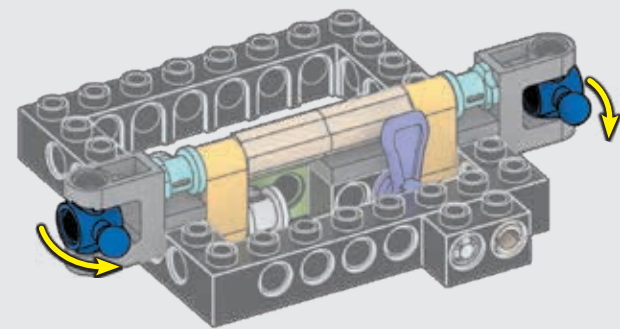

4

42

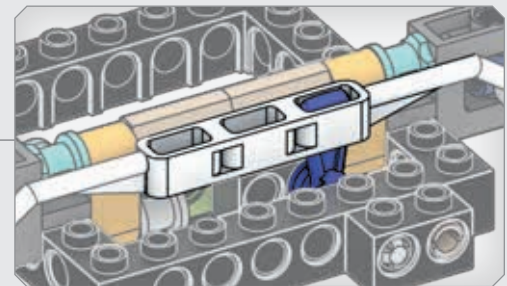
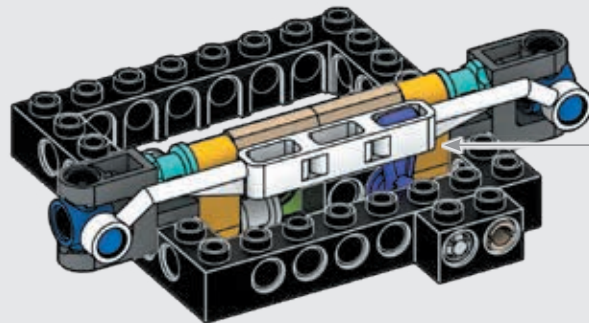
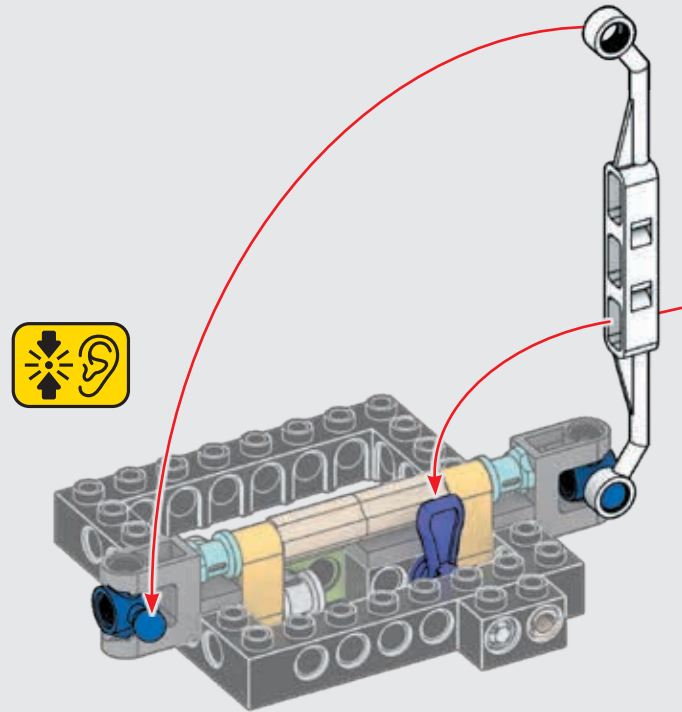
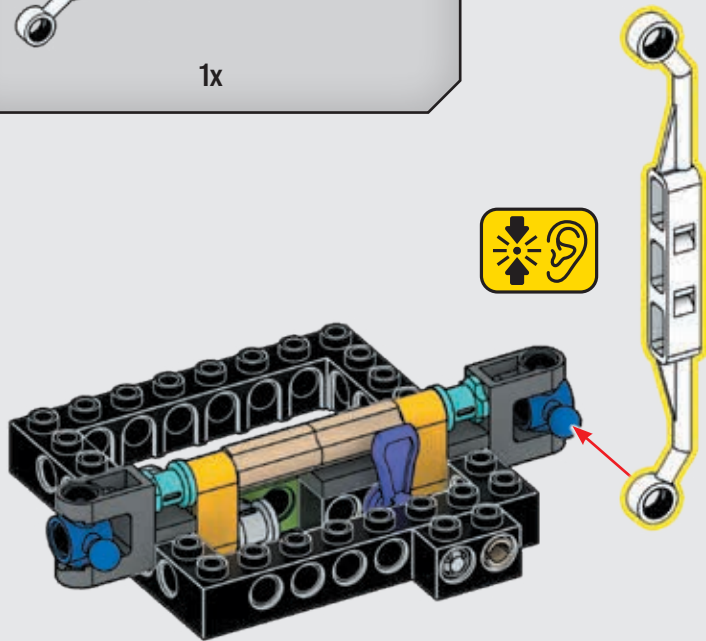
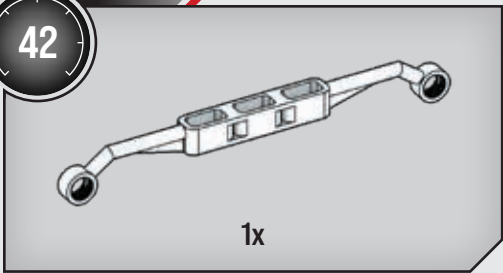

43



1x



1x



1x

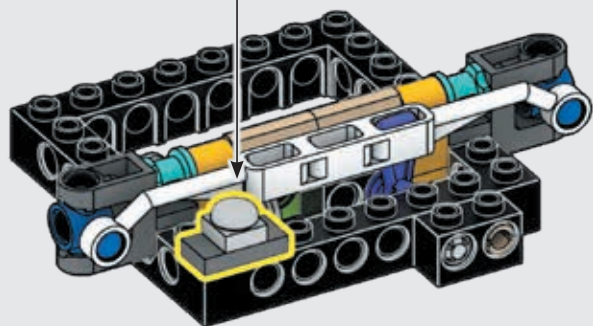
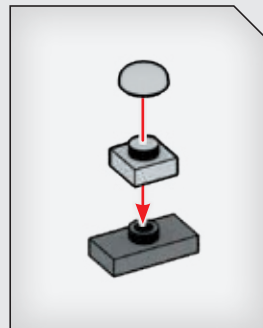

44



1x



1x

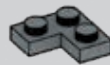

1x

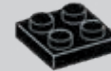

1x

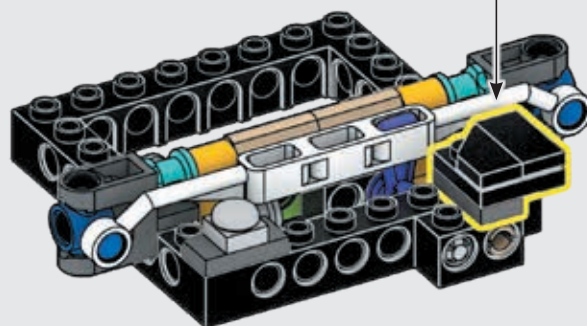
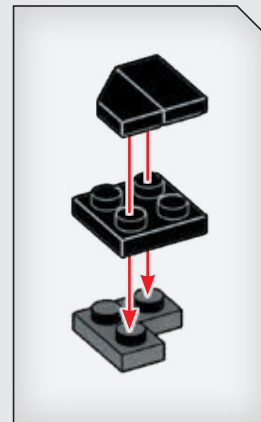

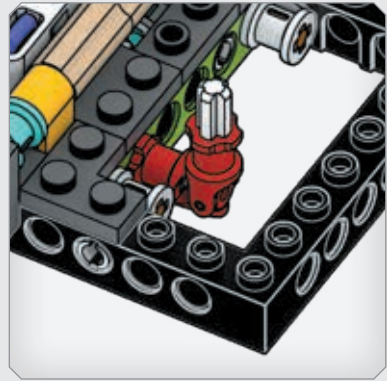
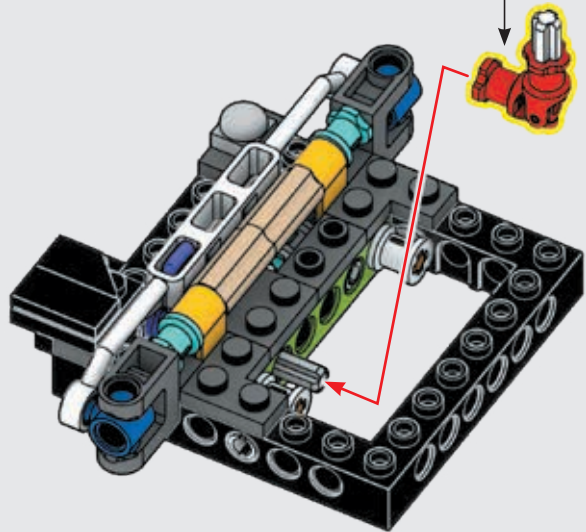
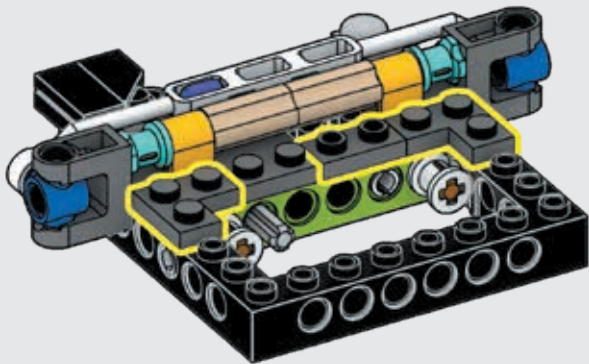
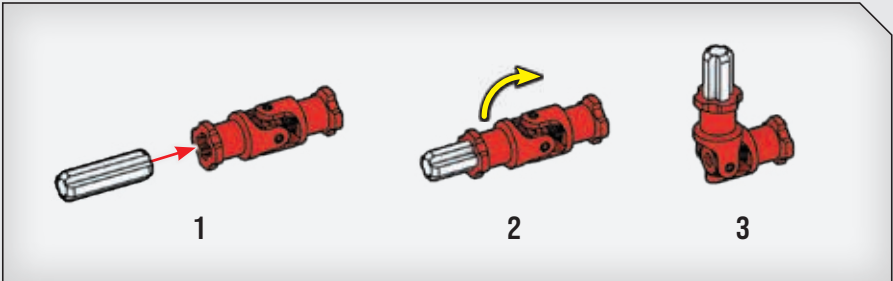
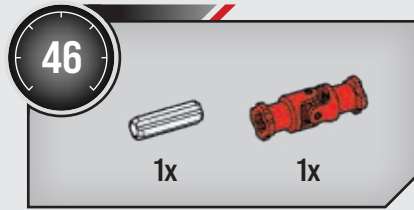
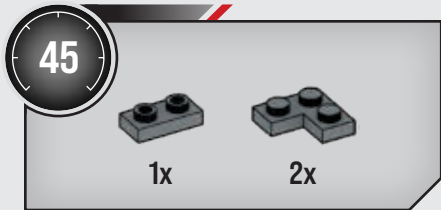

47

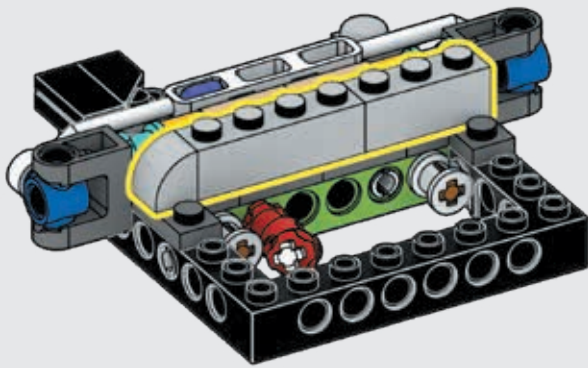
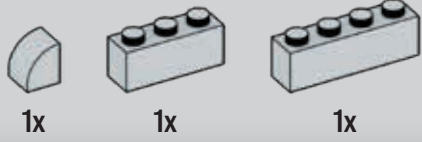

48

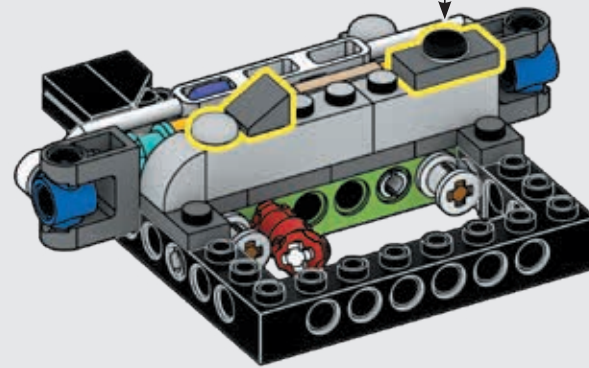
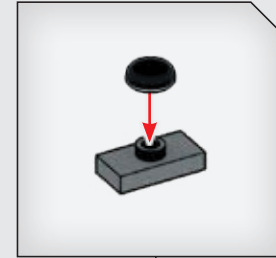

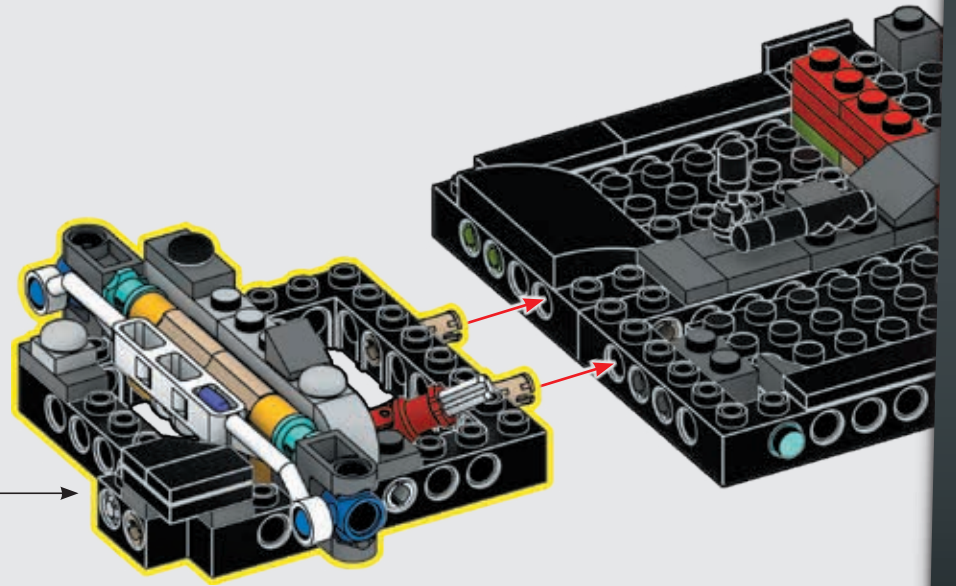
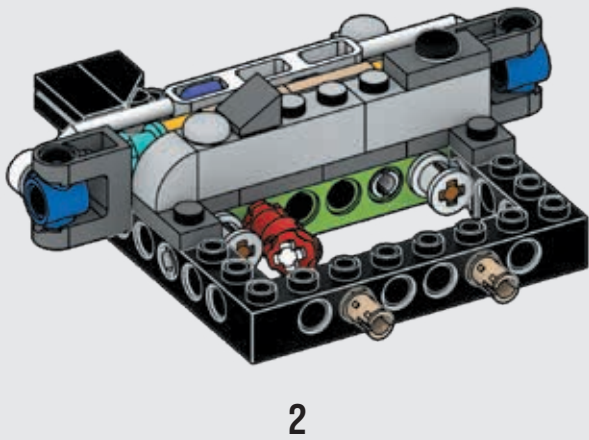
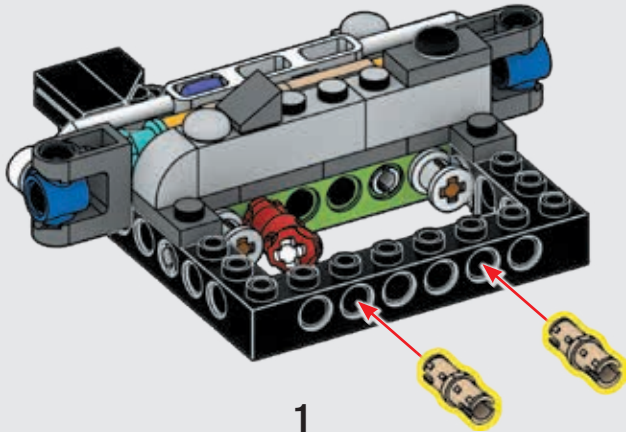
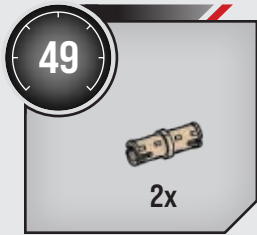

51

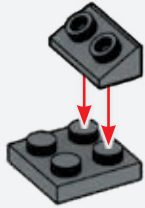

1

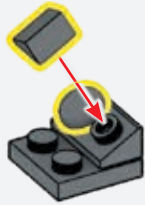

2

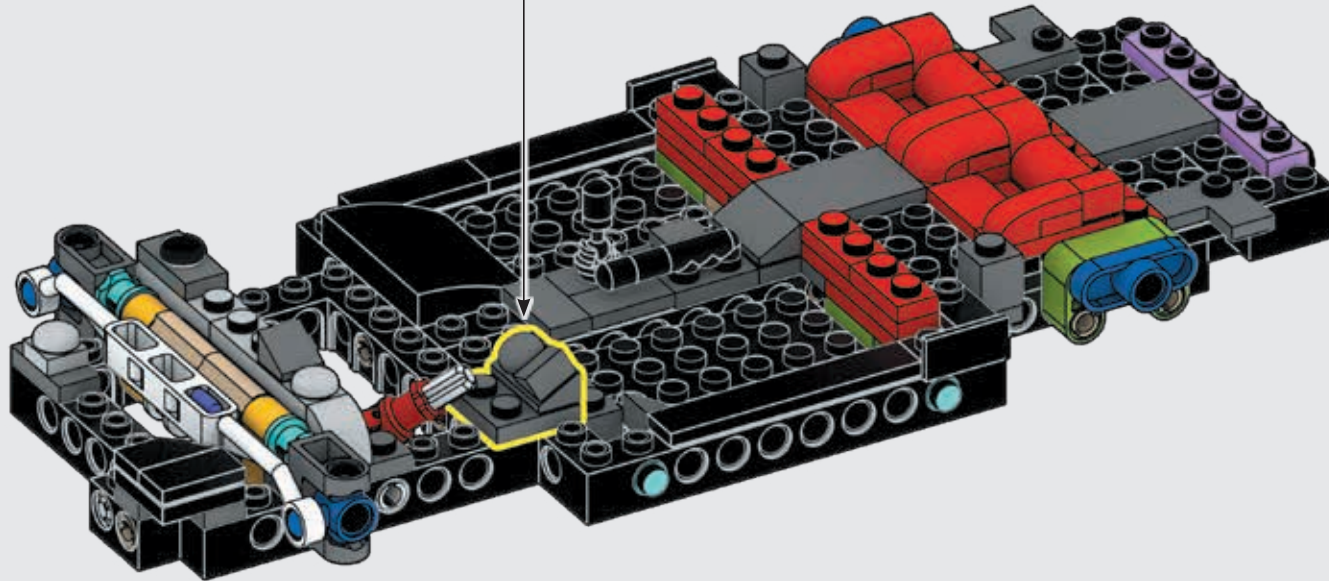

52



1x

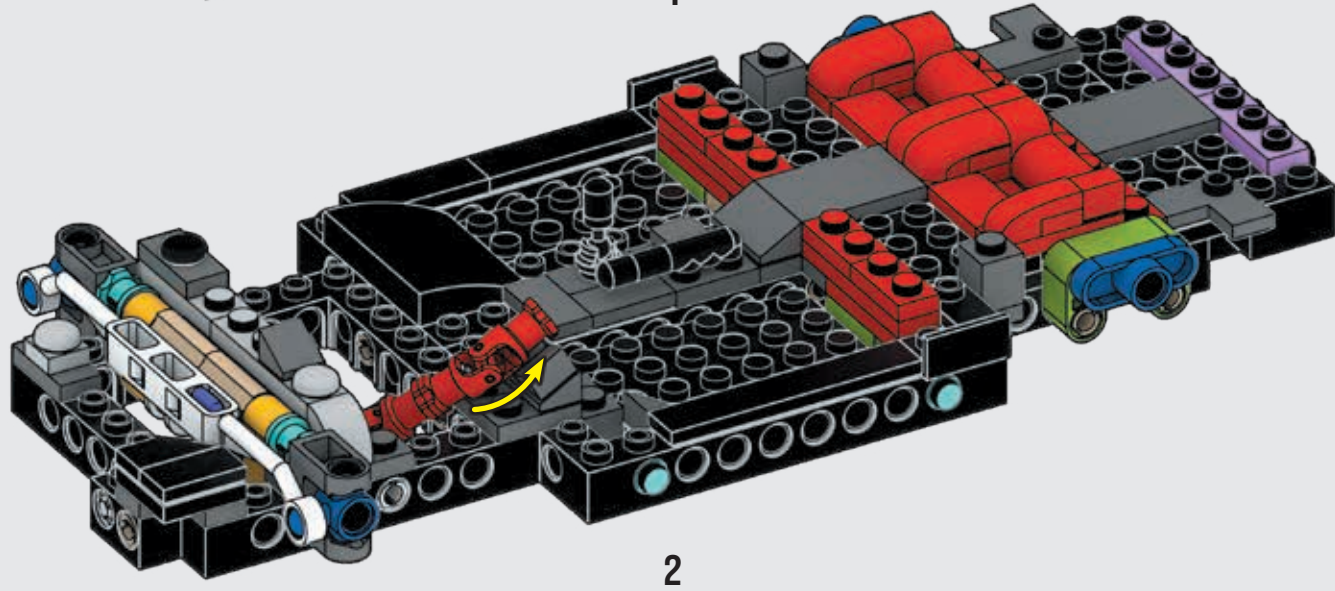
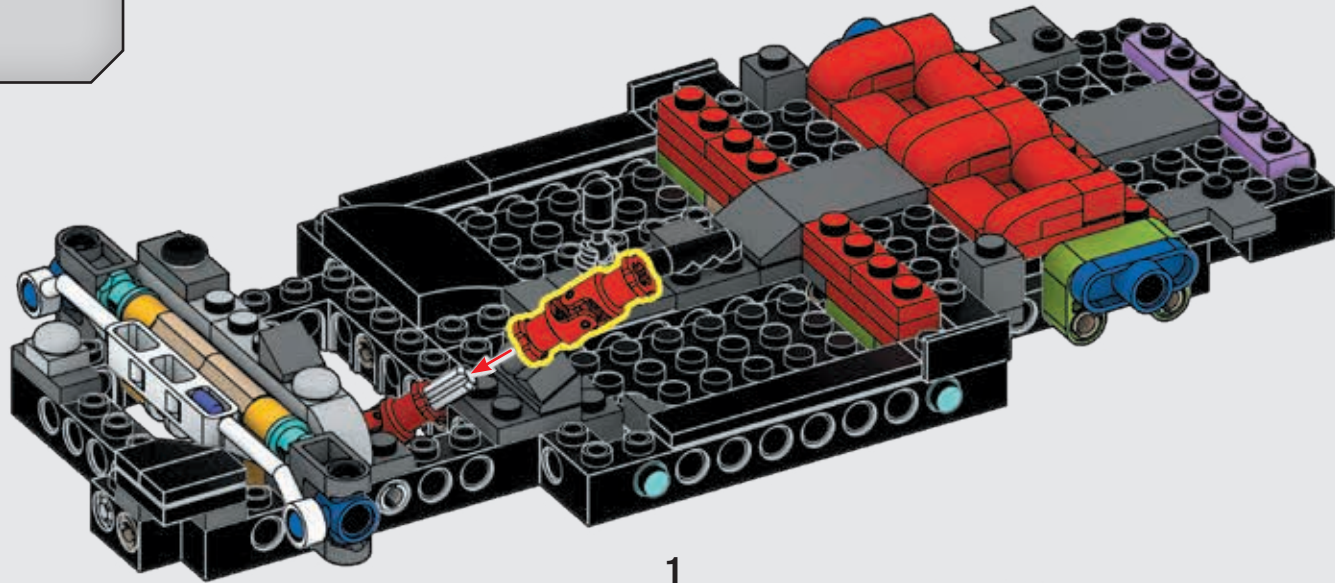



53

1x8
1x

2x8
1x

A 1x8 grey Technic beam with 8 holes and a 2x8 black Technic beam with 8 holes and 2 rows of holes.

54

1x **1x**

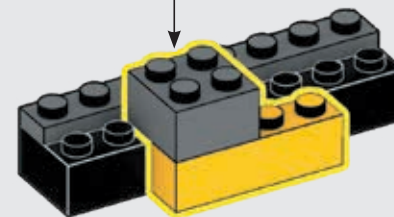
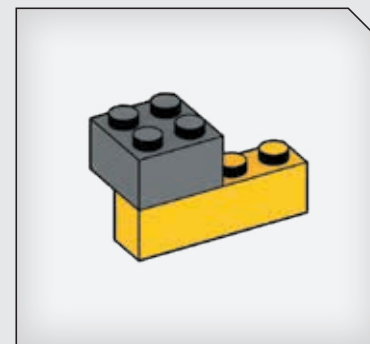
A 1x3 grey Technic brick with 3 holes and a 1x4 yellow Technic brick with 4 holes.

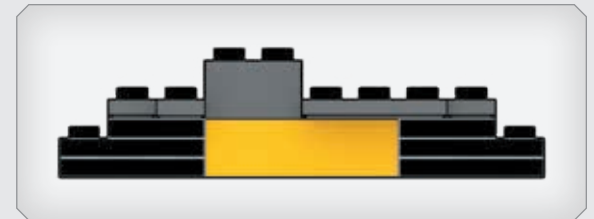
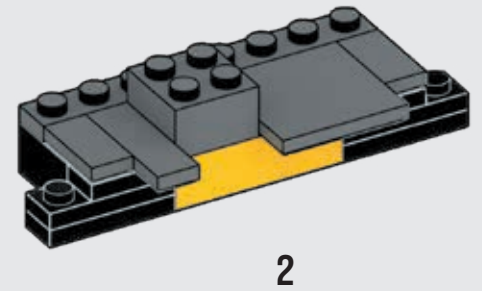
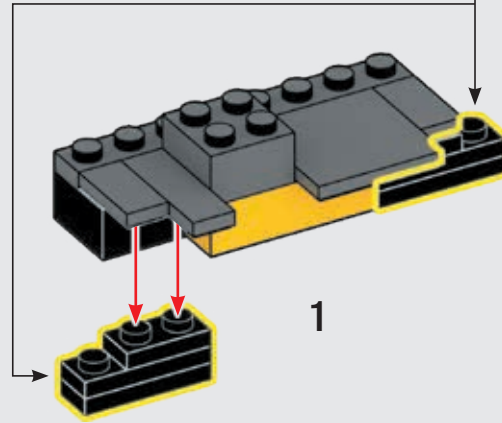
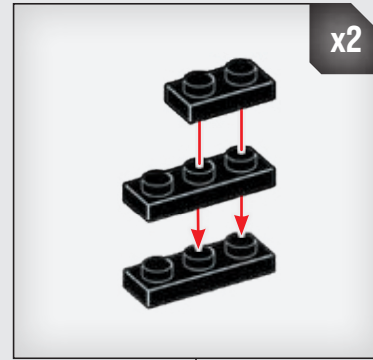
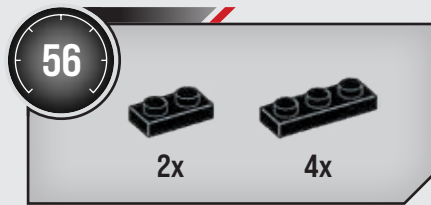
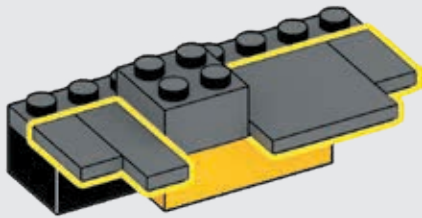
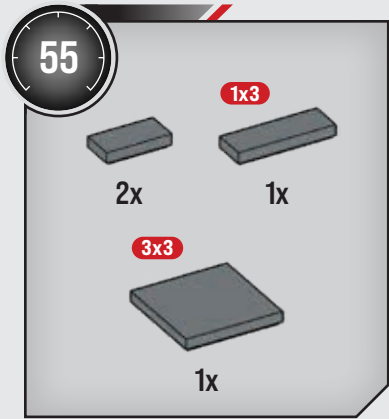

57

2x8



2x

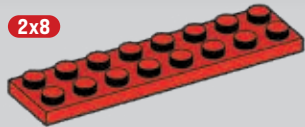

1x

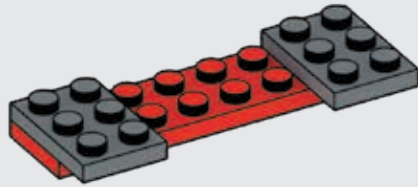

58



2x

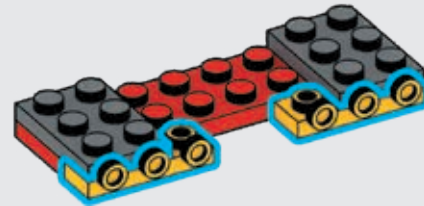

59



1x



1x

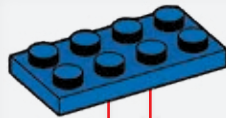

1

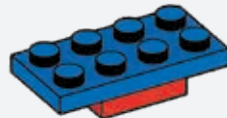

2

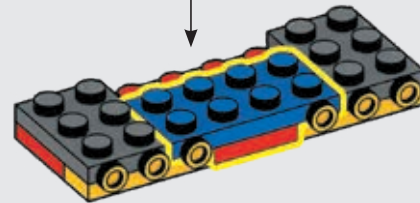

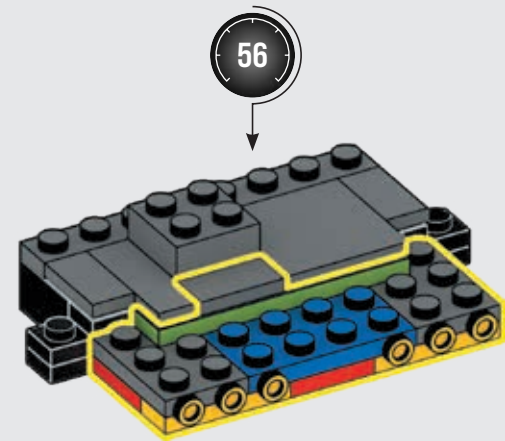
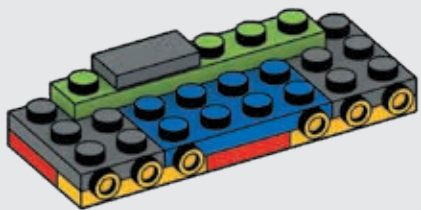
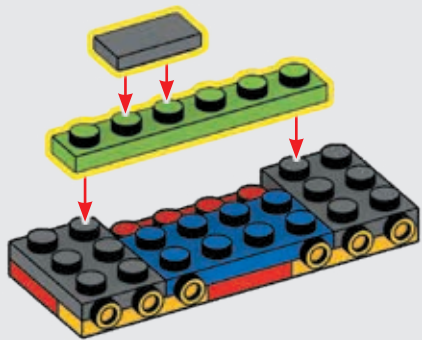
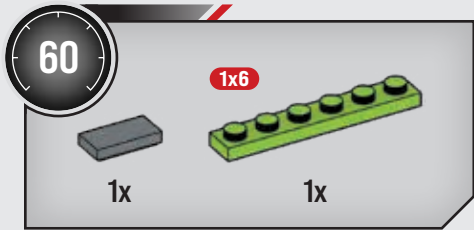

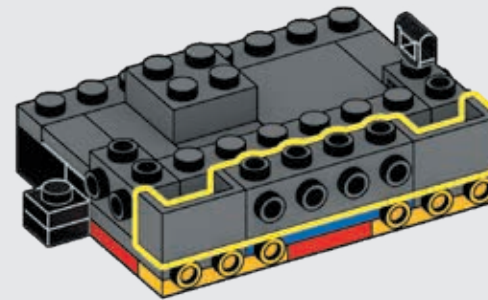
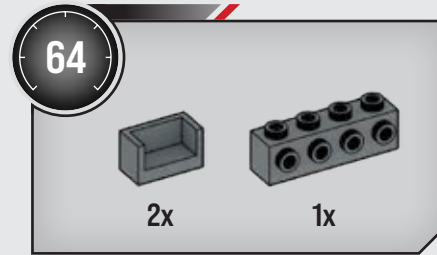
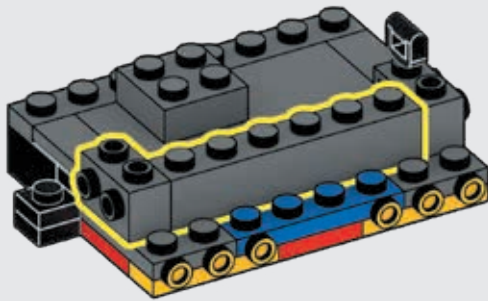
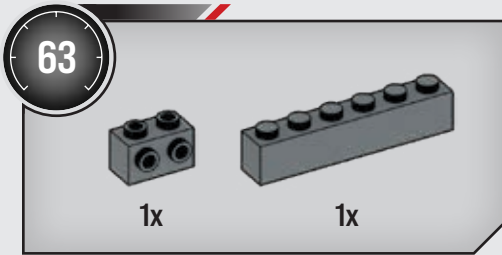
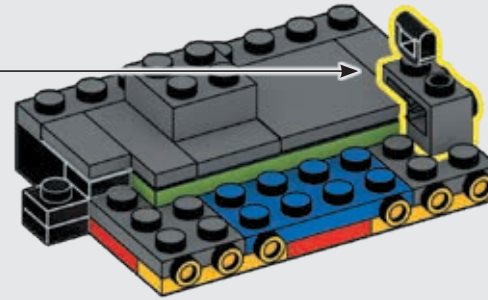
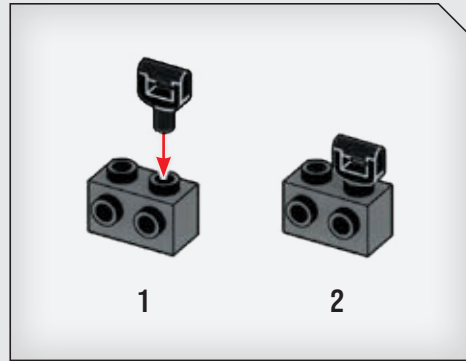
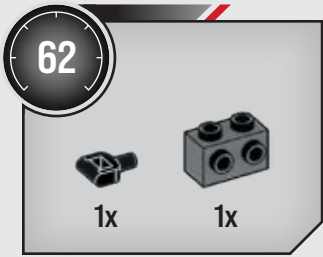

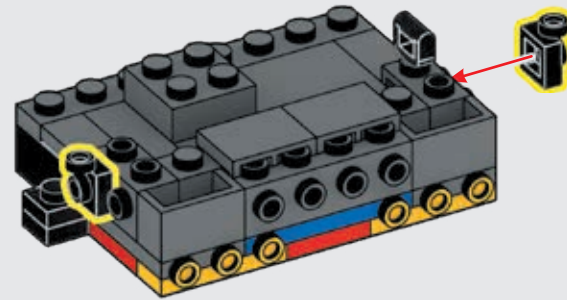
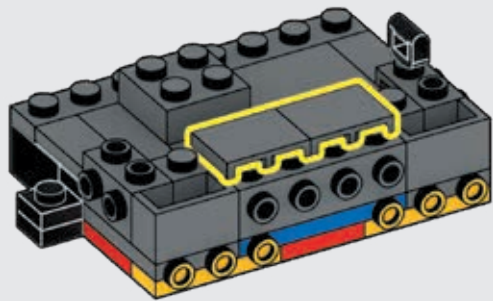
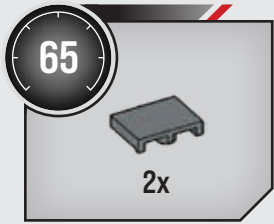

1

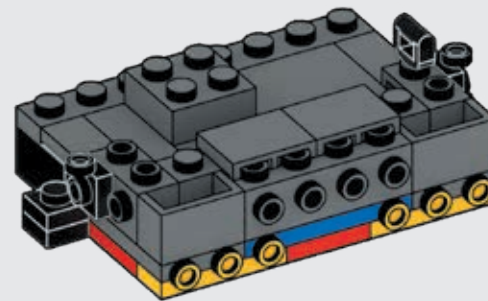

2

67

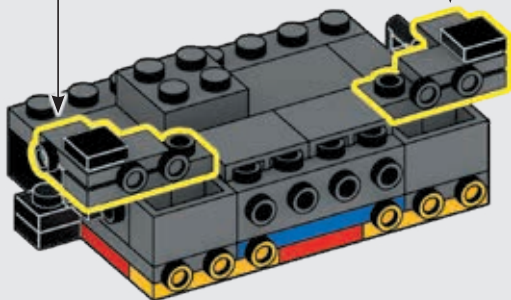
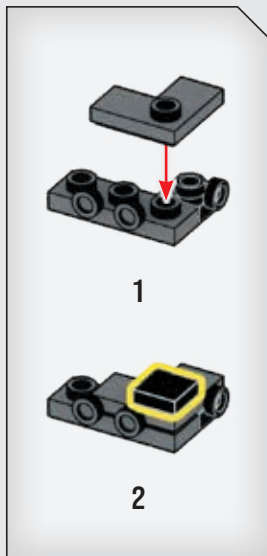
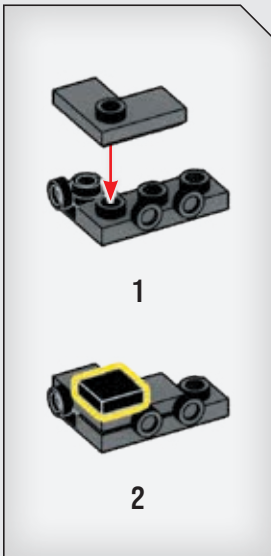

68

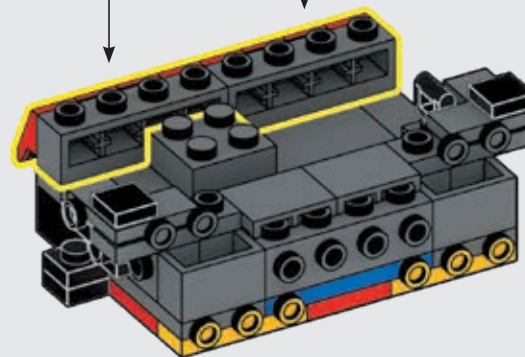
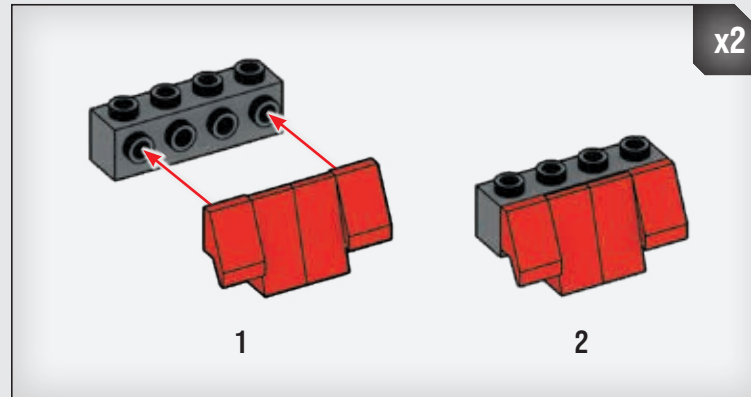
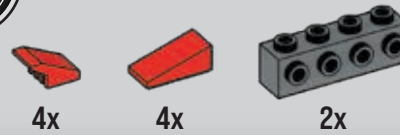

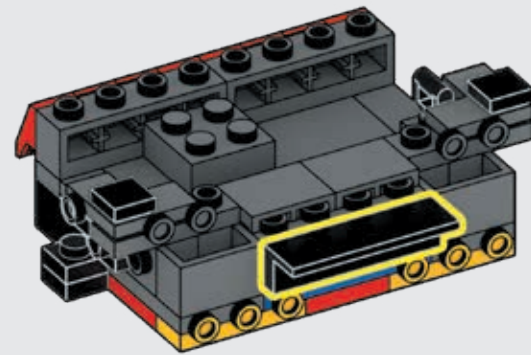
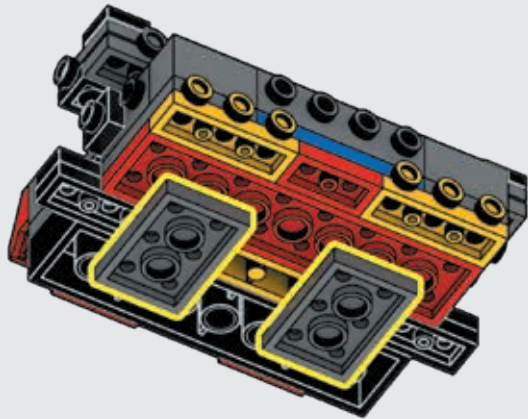
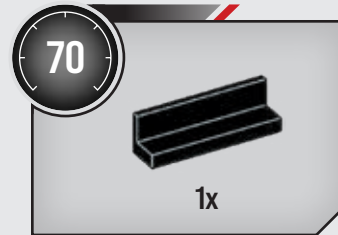

71

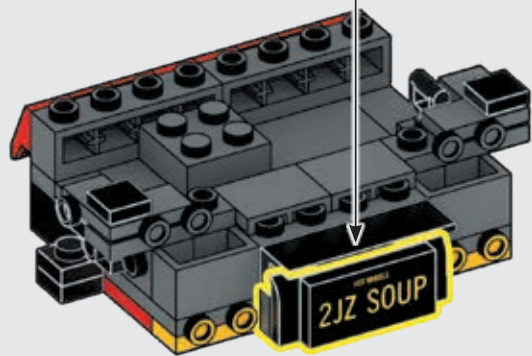
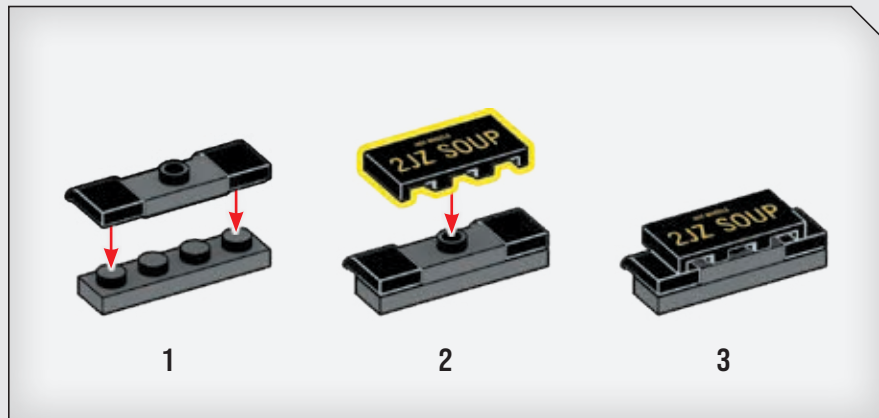

72

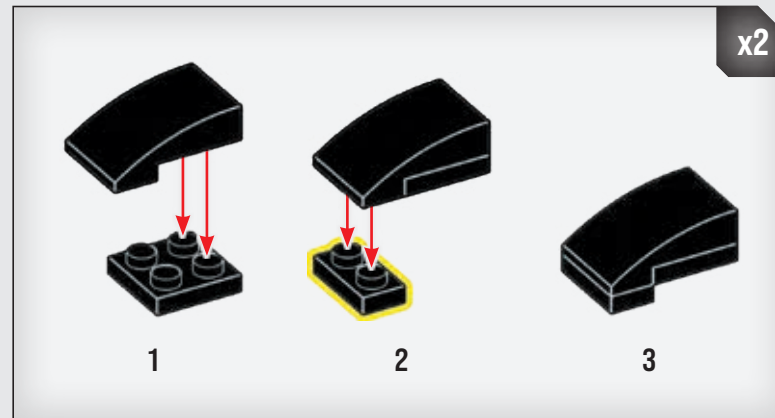

x2

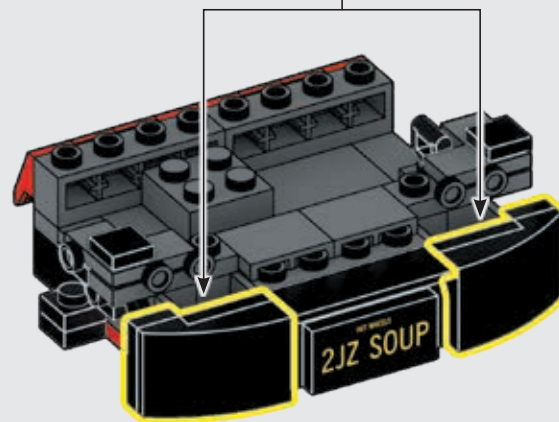

73



2x



2x



1x



1x

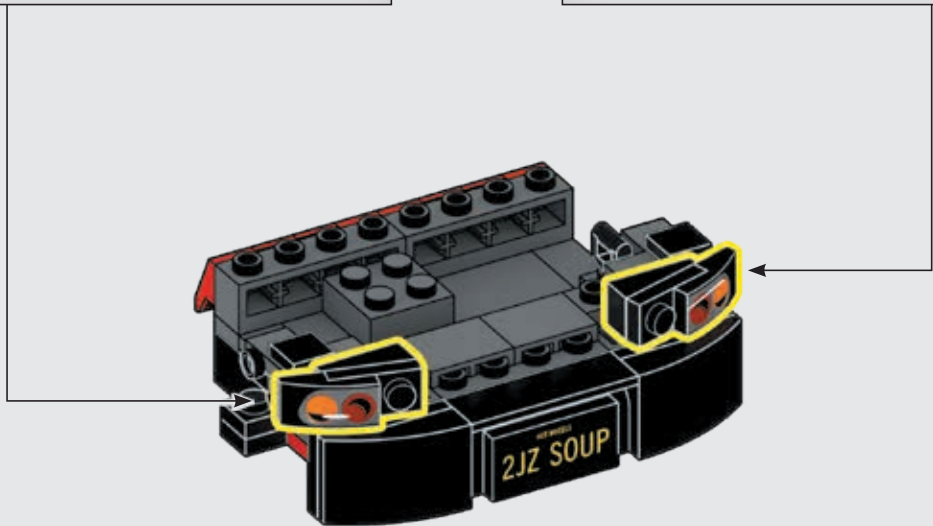
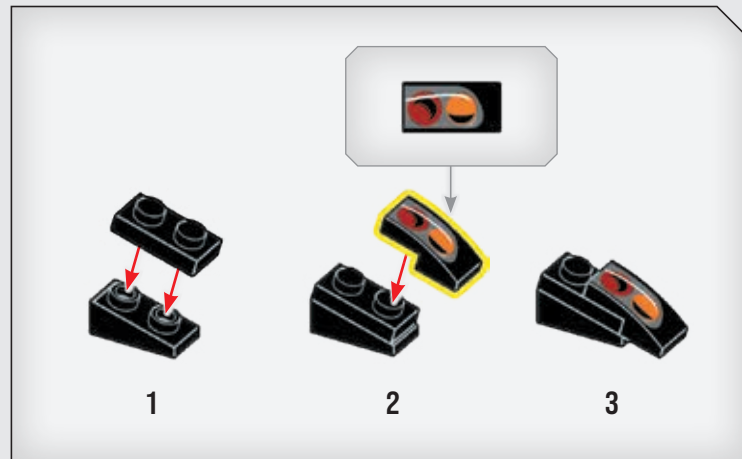
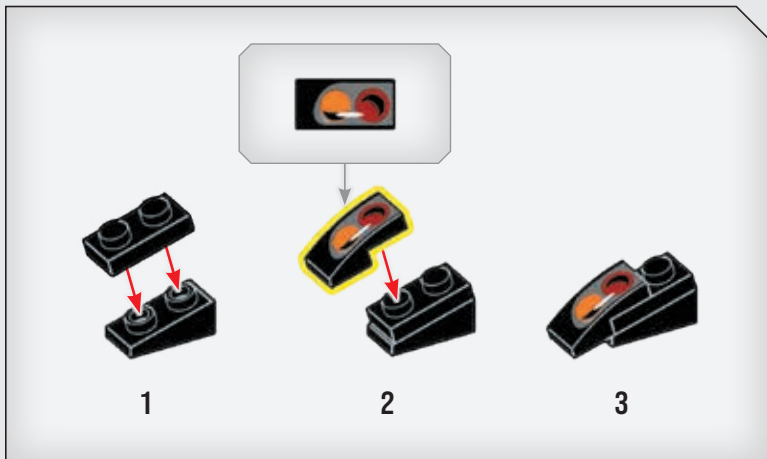

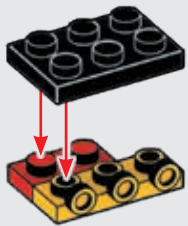
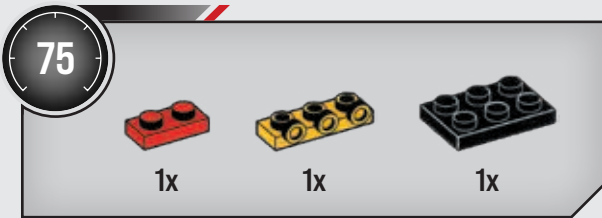
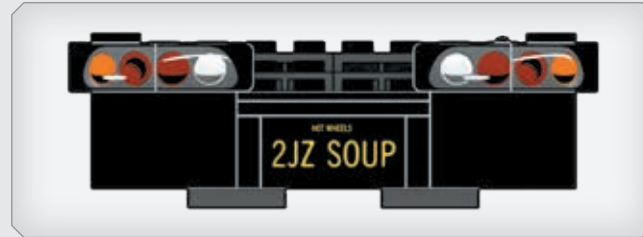
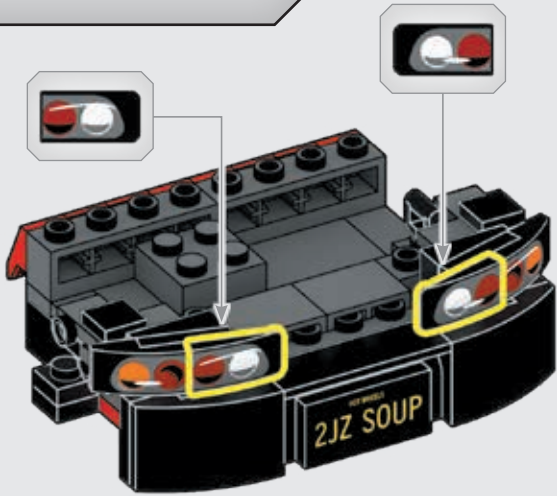
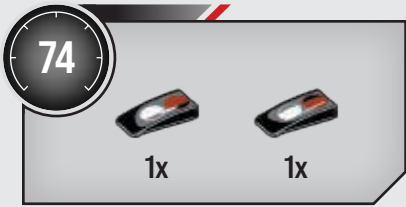

1

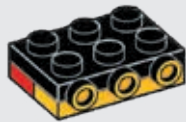

2

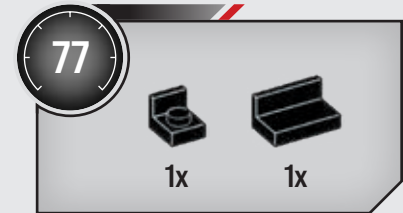

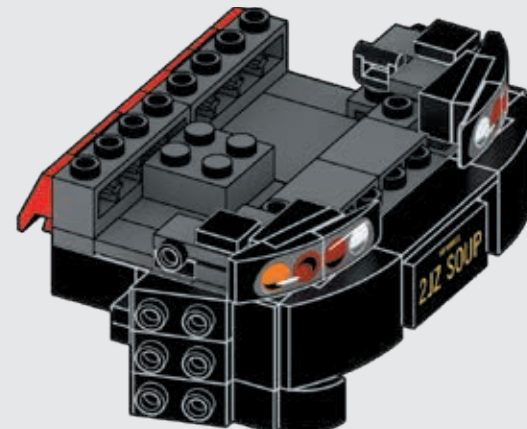
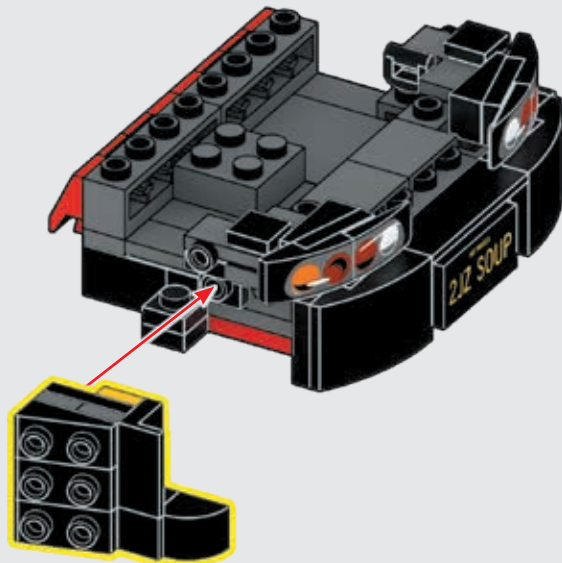
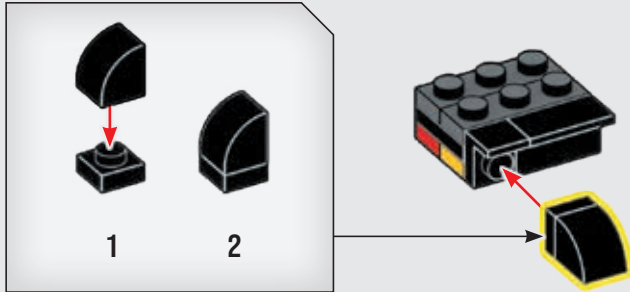

81

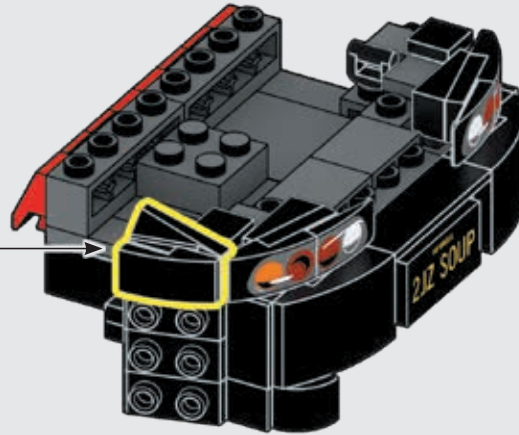
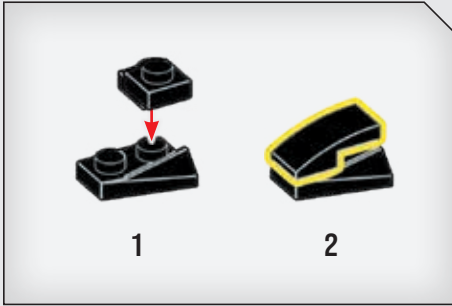

82

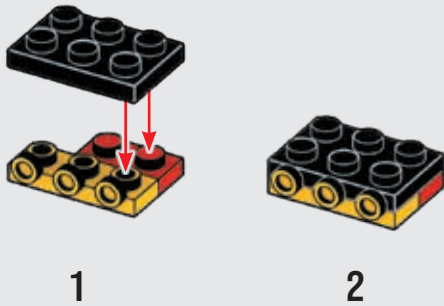

83

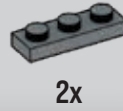

84



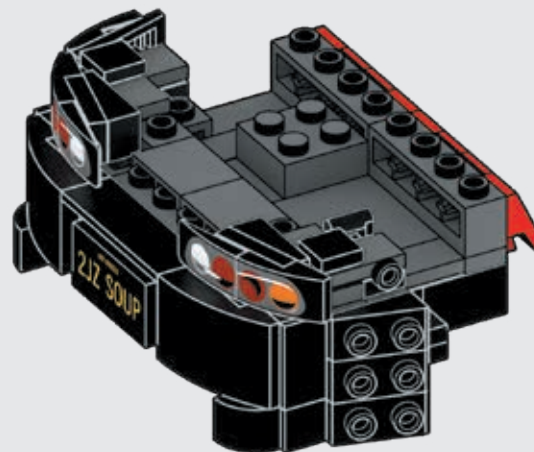
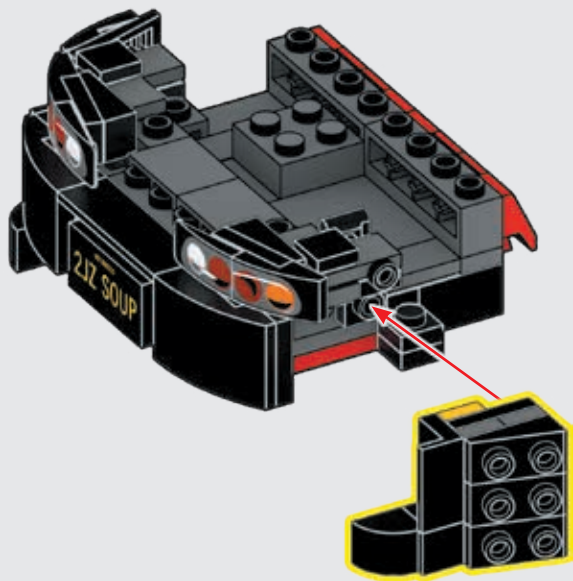
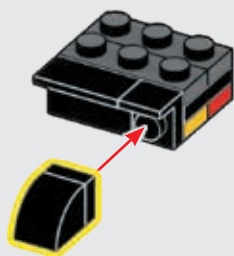
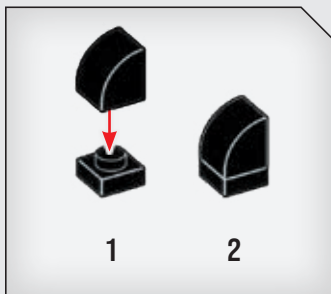
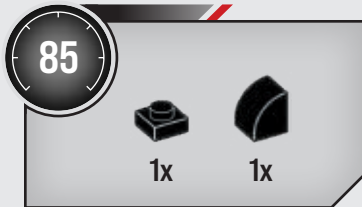

88



1x



1x



1x

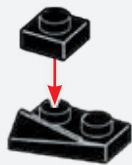

1



2

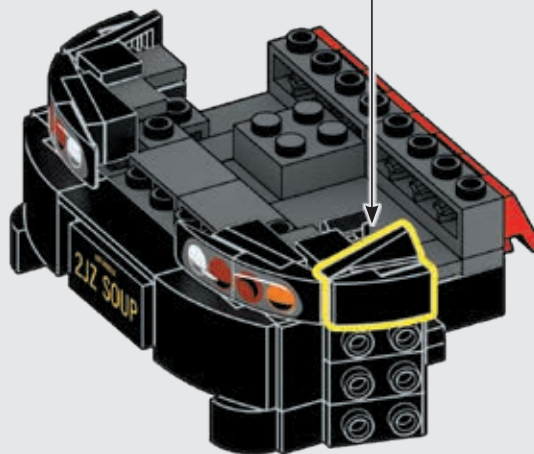

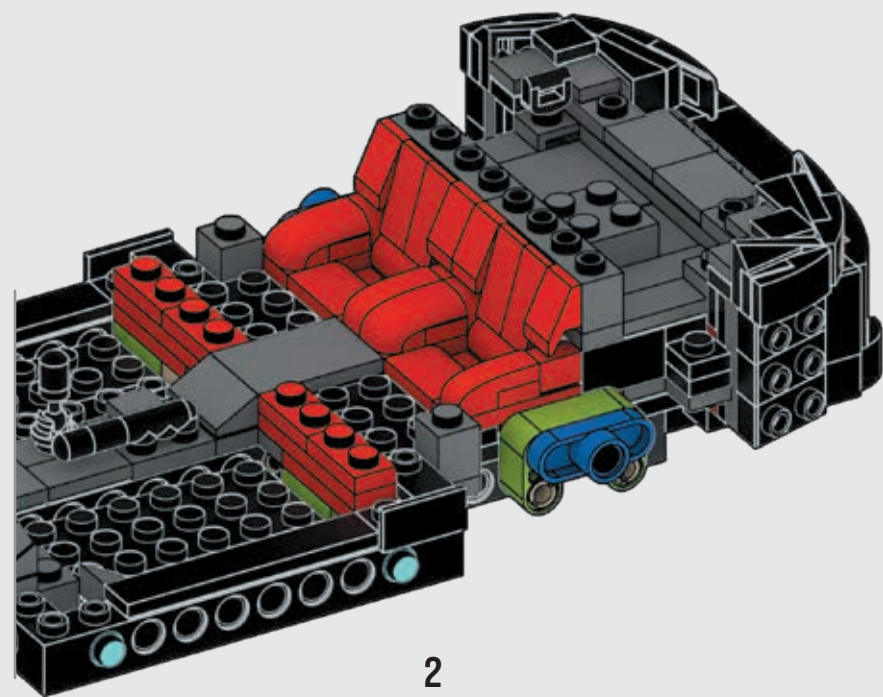
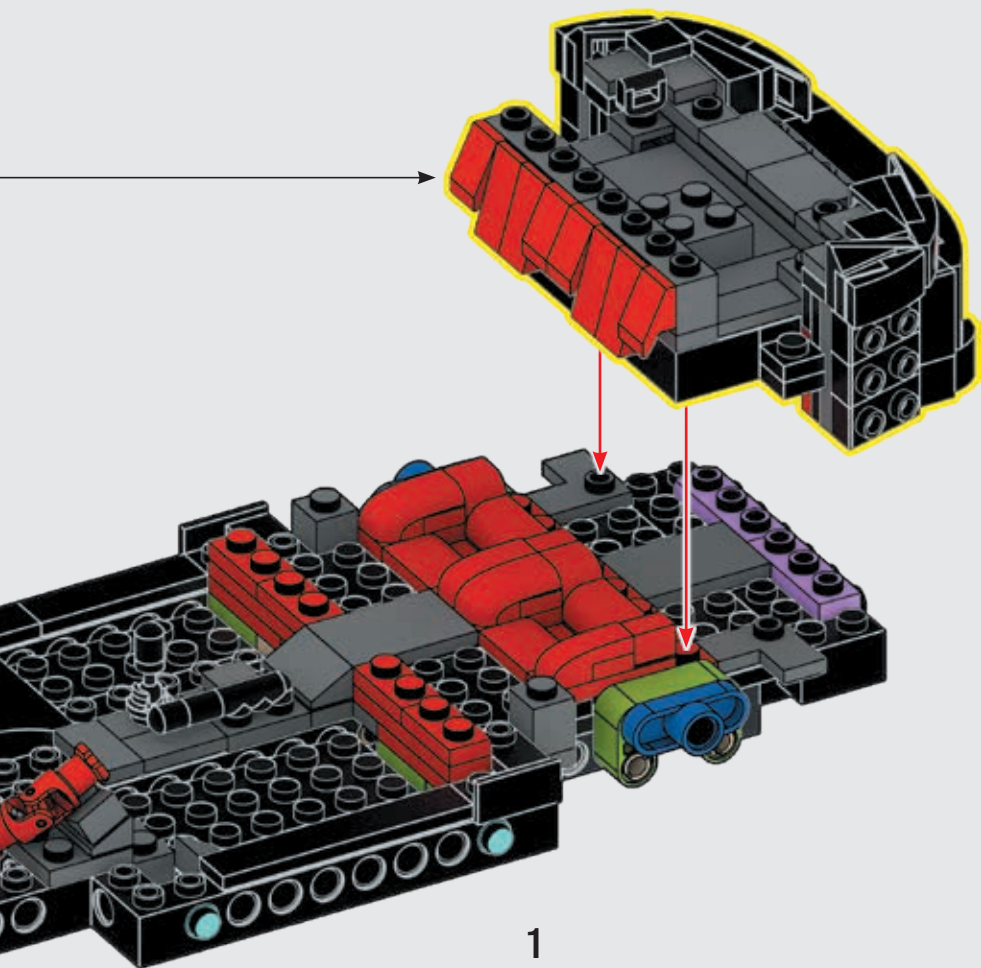

90



1x



1x



2x

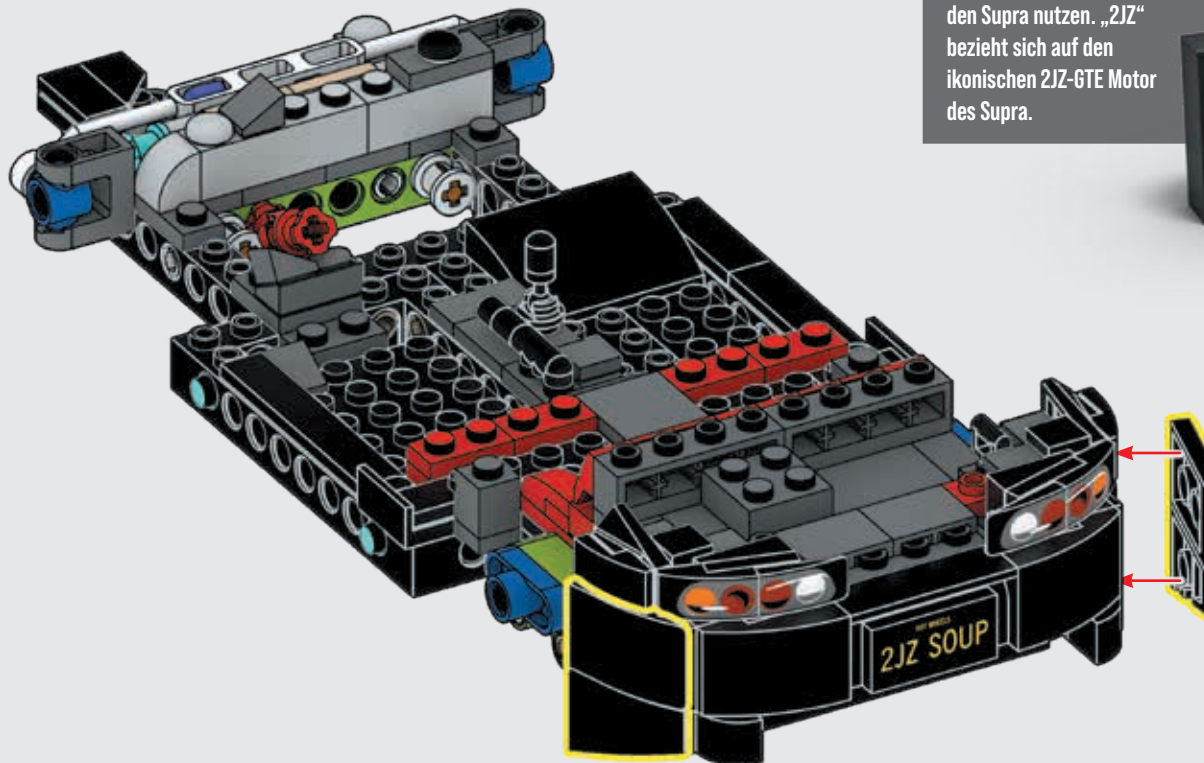

Notice the License plate? 'Soup' refers to the slang term fans use for the Supra. '2JZ' is a reference to the Supra's iconic 2JZ-GTE engine.

Vous avez remarqué la plaque d'immatriculation ? « Soup » fait référence au terme argotique utilisé par les fans pour parler de la Supra. « 2JZ » renvoie au moteur 2JZ-GTE emblématique de la Supra.

¿Has visto la matrícula? "Soup", que significa "sopa", es la forma coloquial con la que los fans se refieren al Supra. "2JZ" es una referencia al icónico motor 2JZ-GTE del Supra.

Schon das Nummernschild entdeckt? „Soup“ bezieht sich auf den umgangssprachlichen Begriff, den Fans für den Supra nutzen. „2JZ“ bezieht sich auf den ikonischen 2JZ-GTE Motor des Supra.



91

1x6



1x

1x8

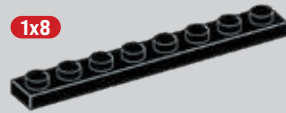

1x

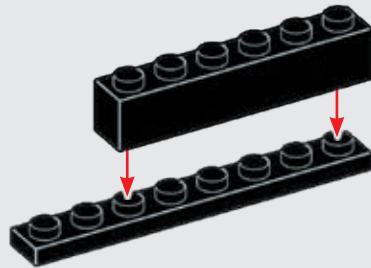

92



1x



1x



1x



1x

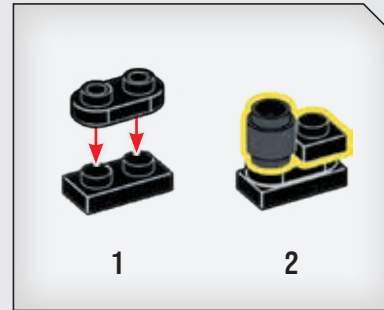

1

2

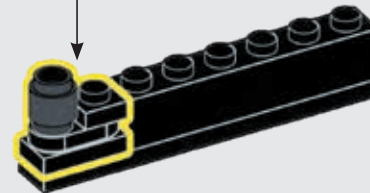

93



2x



1x

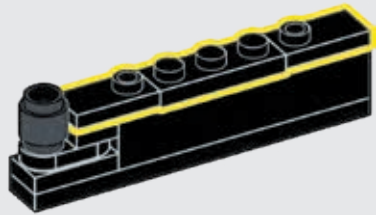

94



1x

1x3



2x

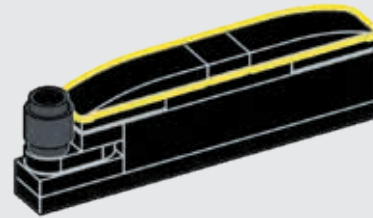

95

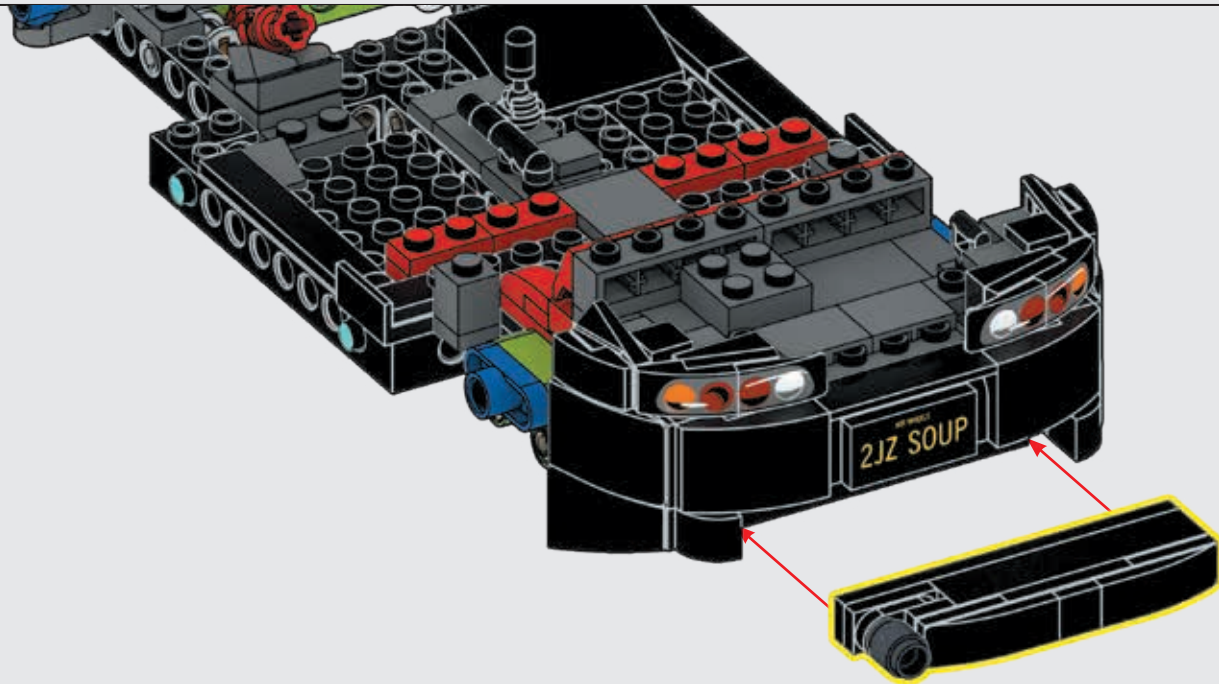

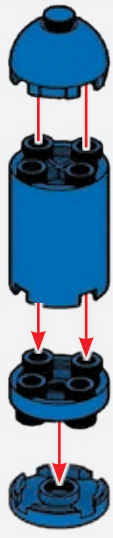
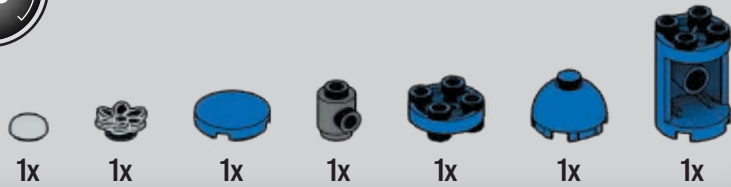

1

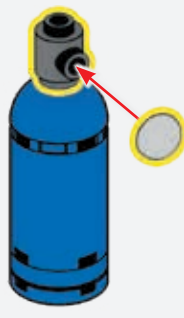

2



3

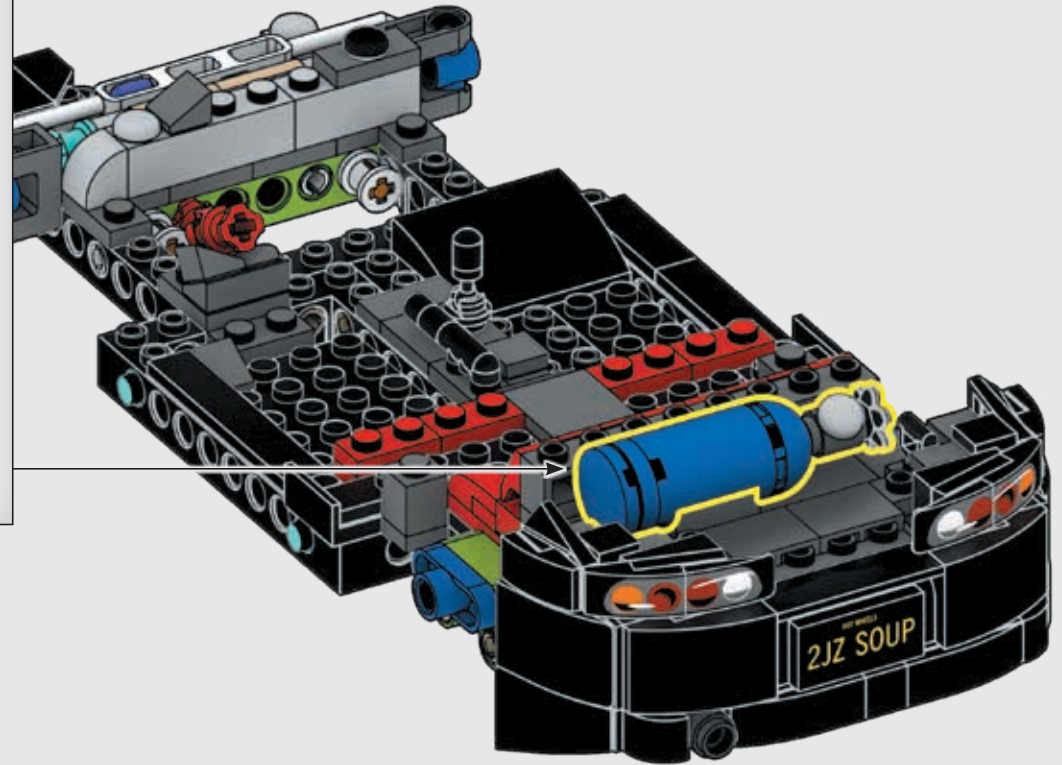

Did you know? 'Supra' derives from the Latin meaning 'to go beyond'.
 Le saviez-vous? « Supra » est issu du latin et signifie « qui va au-delà ».
 ¿Lo sabías? "Supra", en latín, significa "ir más allá".
 Schon gewusst? „Supra“ stammt aus dem Lateinischen und bedeutet so viel wie „Über das Ziel hinausgehen“.

97

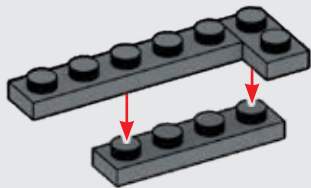
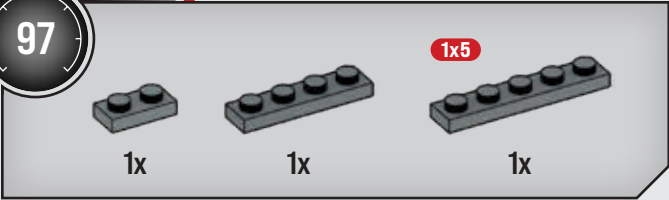

98

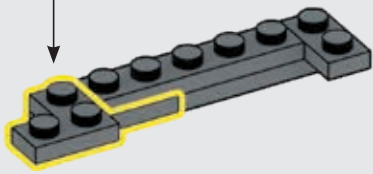
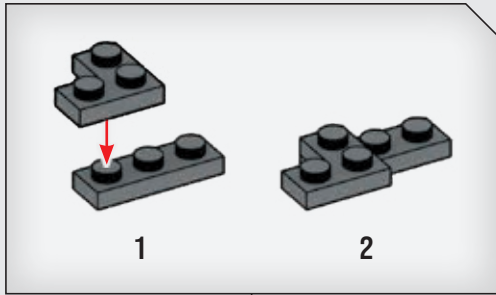
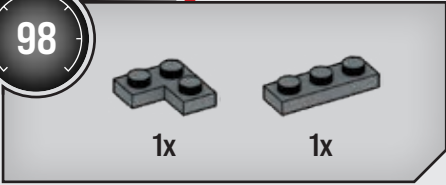

99

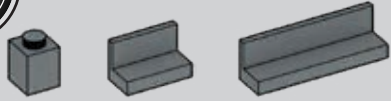

1x

1x

1x

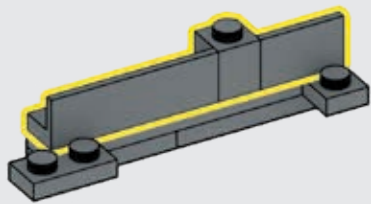

100



2x

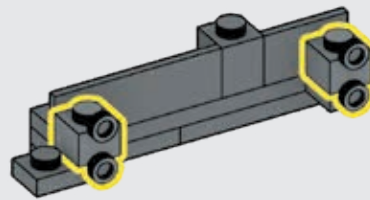

101



2x



1x

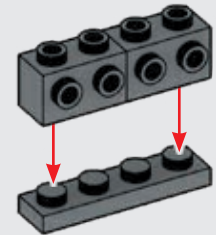



1x



1x



1x



1x



1x



1x

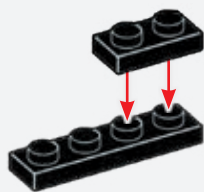

1

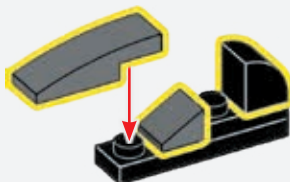

2

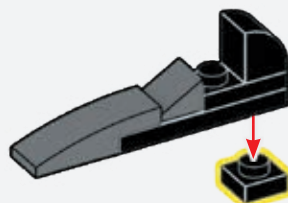

3

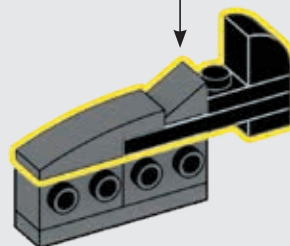

103

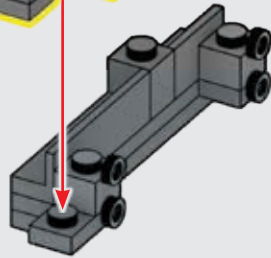
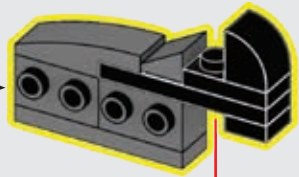

1

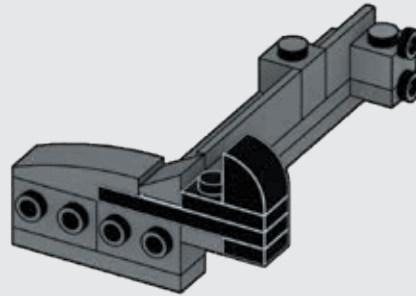

2

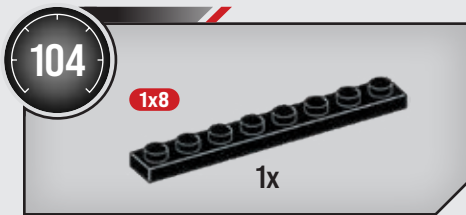

104

1x8

1x



105

1x

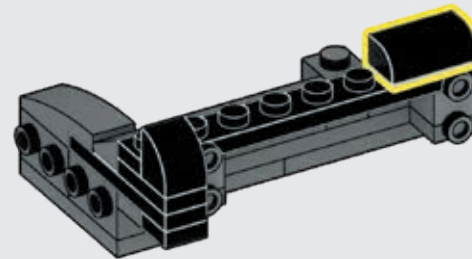
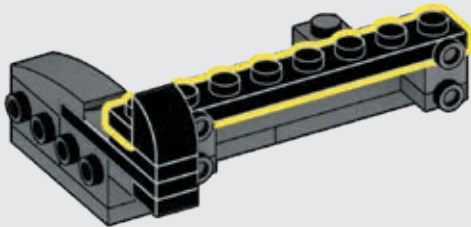

106



1x



1x



1x



1



2

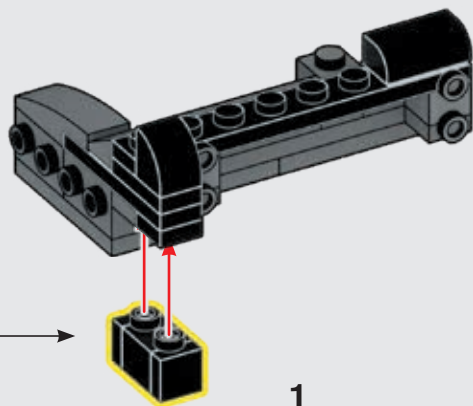

1

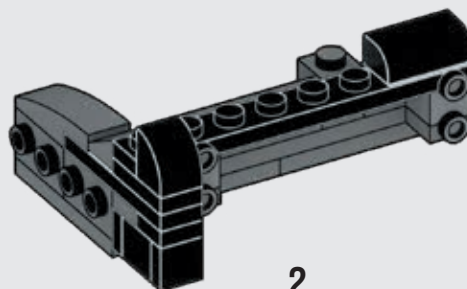

2

107

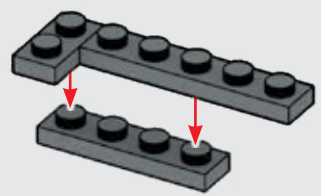

108

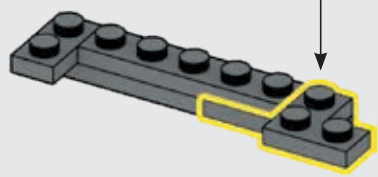
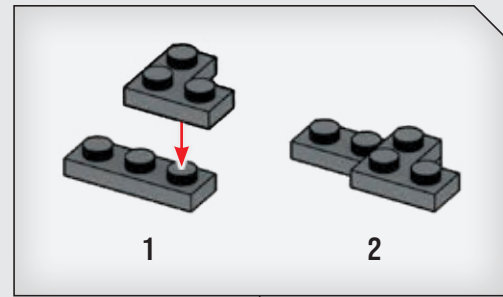
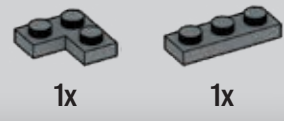

109

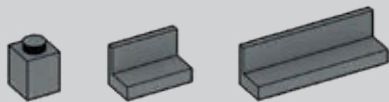

1x

1x

1x

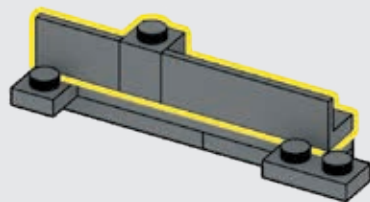

110



2x

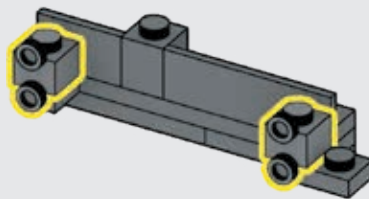

111



1x



2x

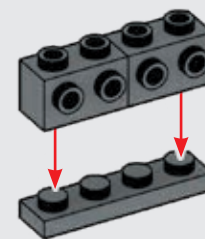

112

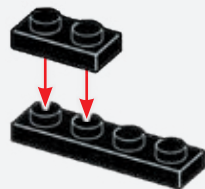

1

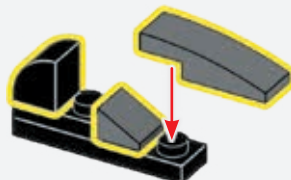

2

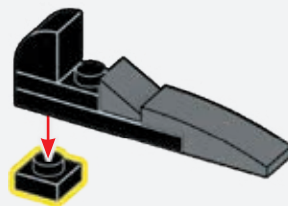

3

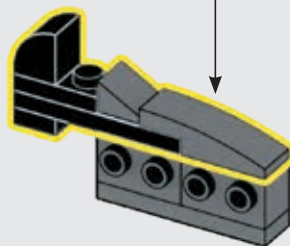

113

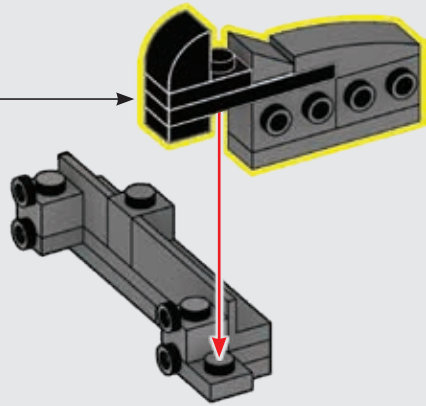

1

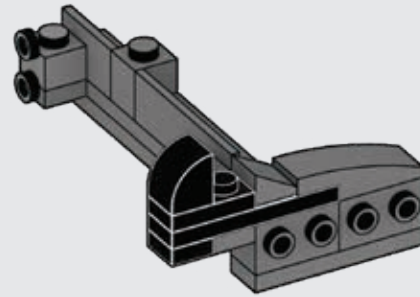

2

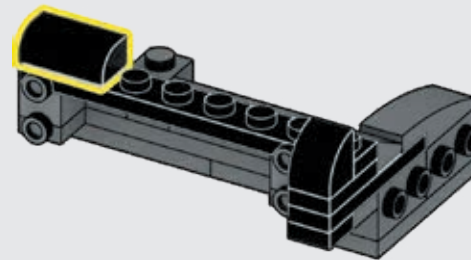
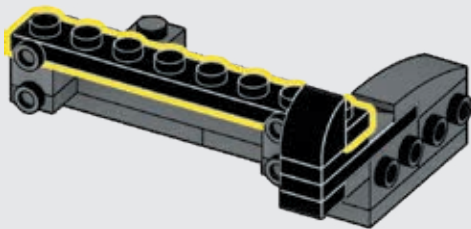
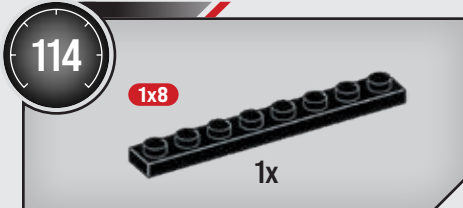

116



1x



1x



1x



1



2

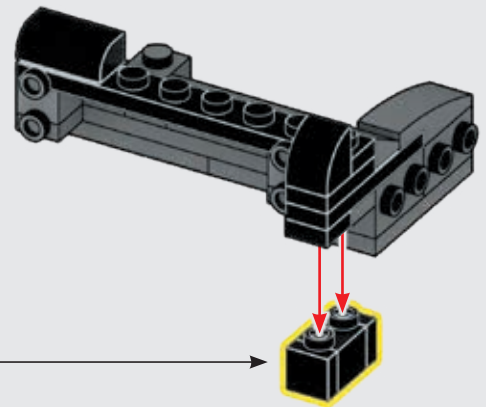

1

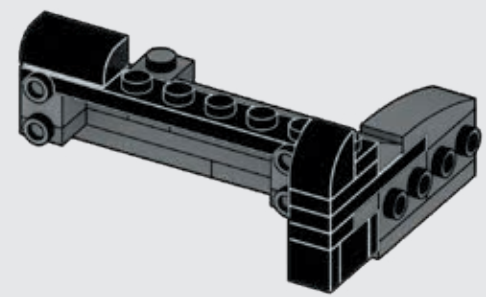

2

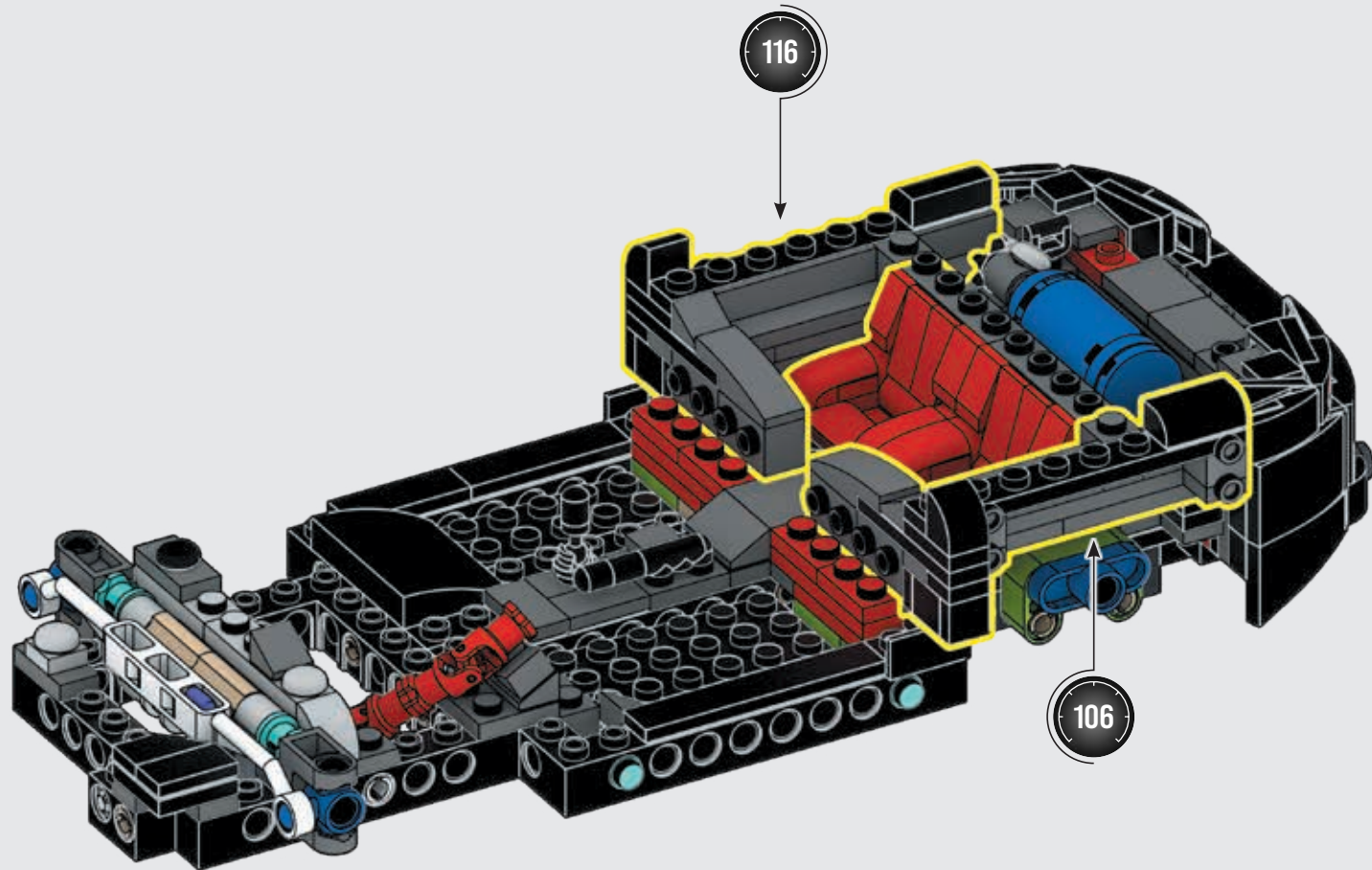

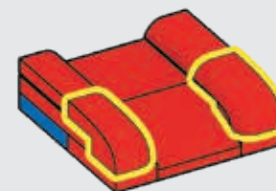
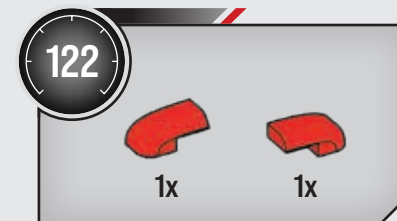
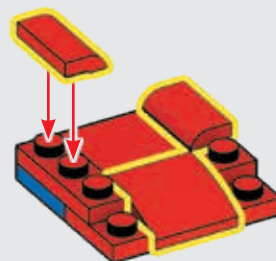
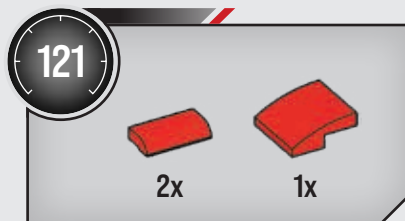
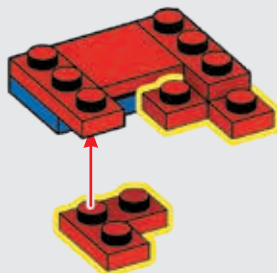
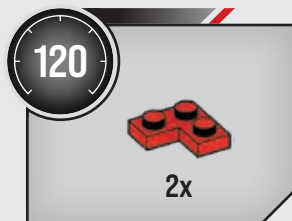
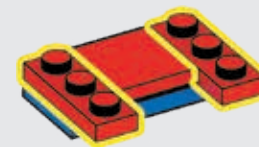
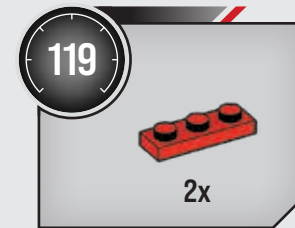
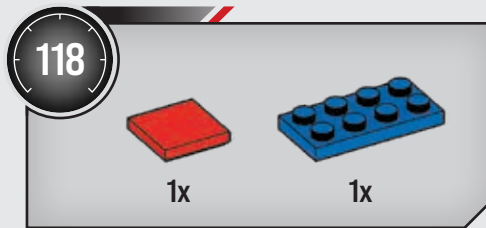
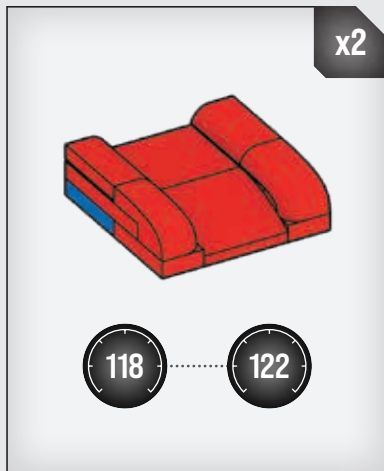

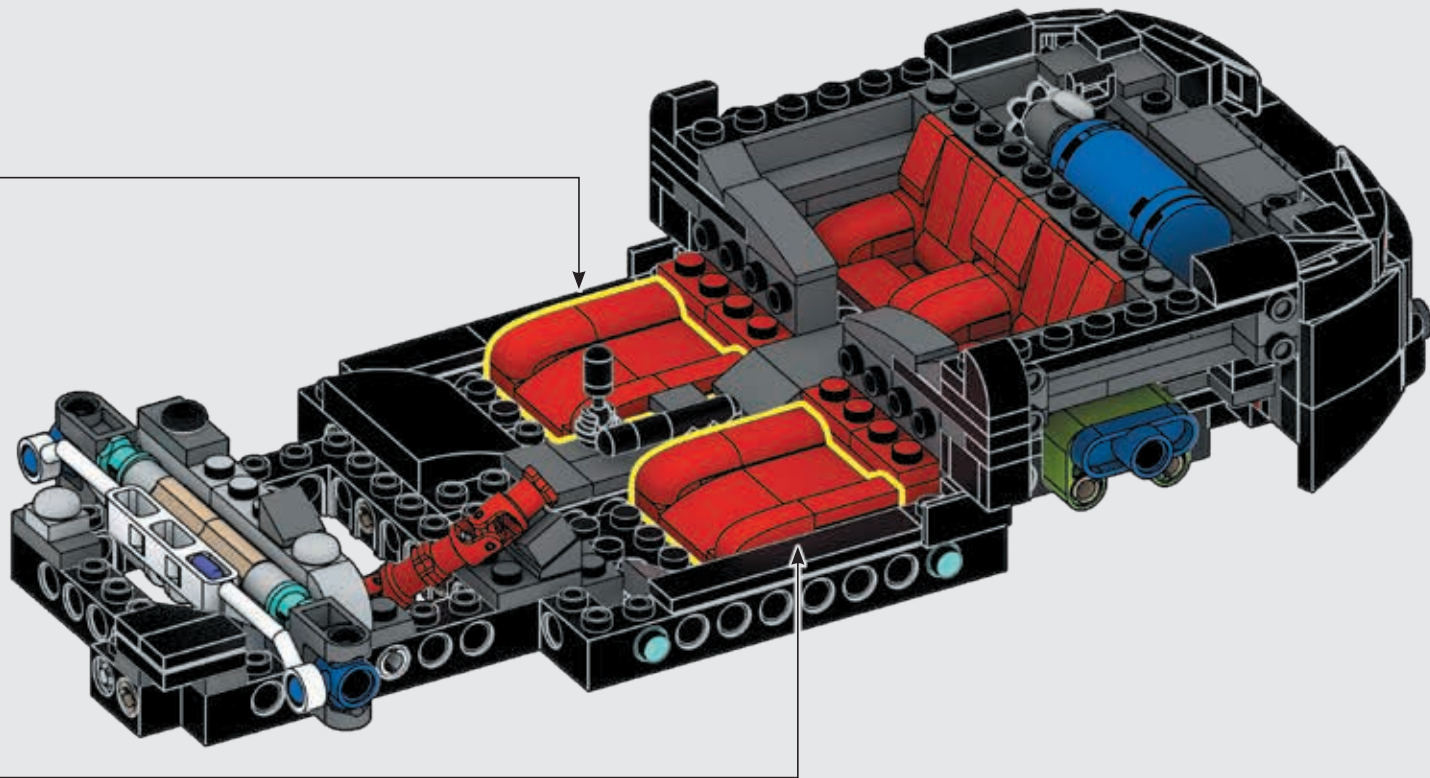

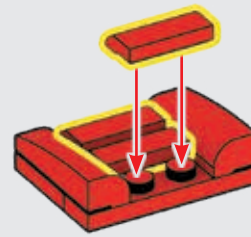
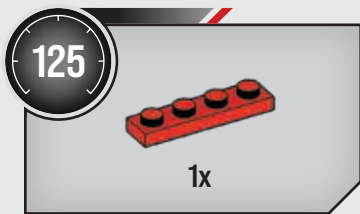
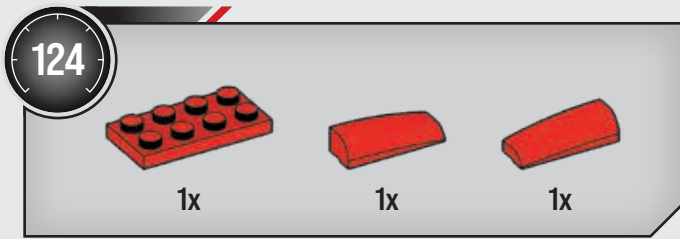

1

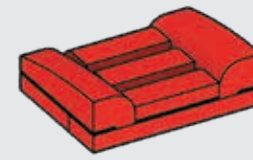

2

127



2x

1x

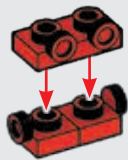

128



1x



129



2x

1x

1x

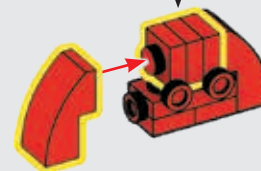
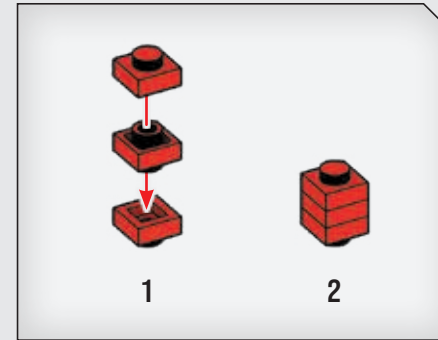

130

1x 1x

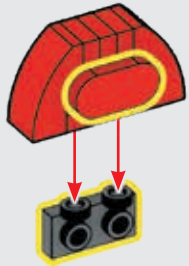

1

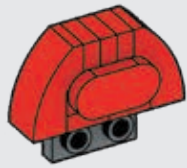

2

131



126

132

2x

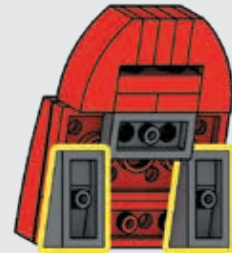

Our designers chose red bricks for the seats to give the build a bold pop of color.

Nos designers ont choisi des briques rouges pour les sièges afin de donner à la construction une touche de couleur audacieuse.

Nuestro equipo de diseño eligió bloques rojos para los asientos, lo que aporta a la construcción un toque de color atrevido.

Unsere Designer haben rote Teile für die Sitze ausgewählt, um dem Bauset einen kräftigen Farbakzent zu verleihen.

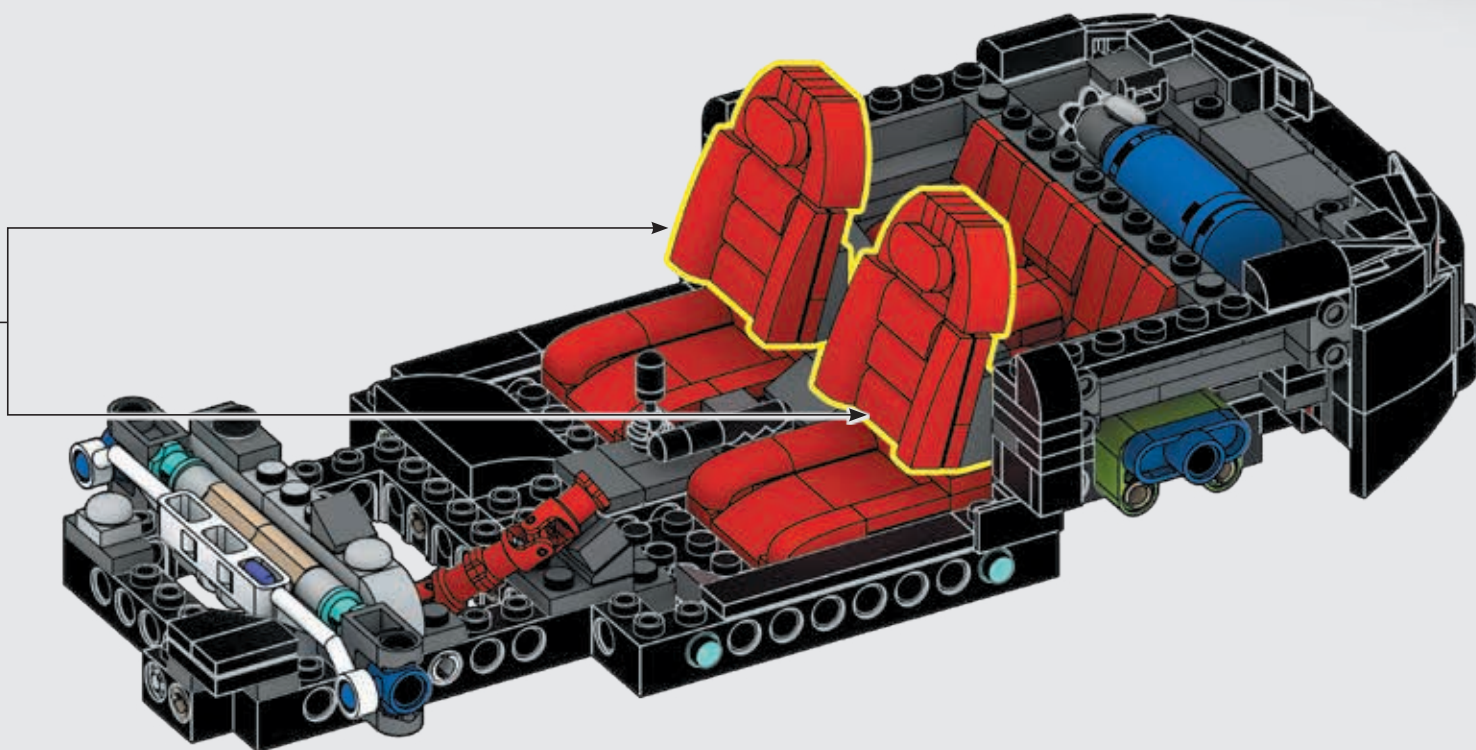

134



1x

1x3



1x

1x8



1x



135



1x



1x

1x8

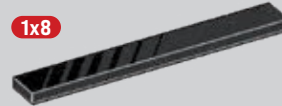

1x

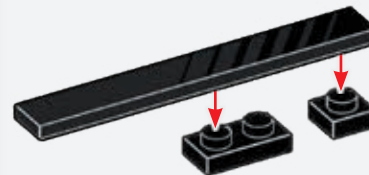

1



2

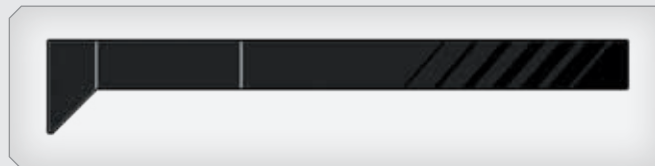

136

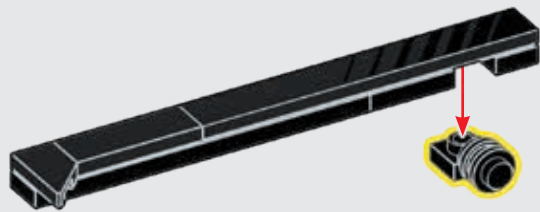
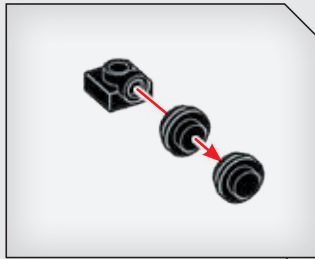

1

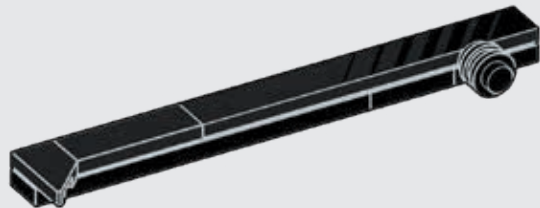

2

137

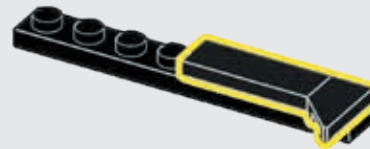

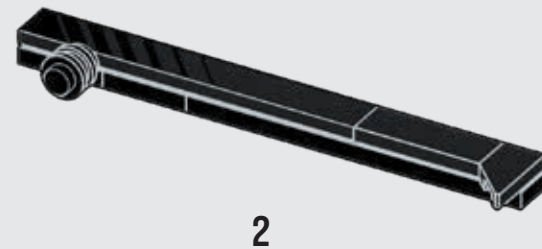
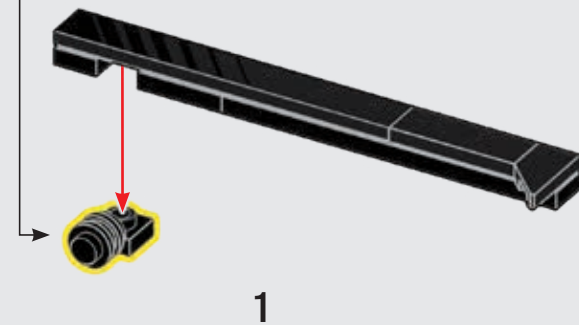
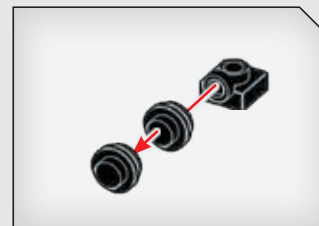
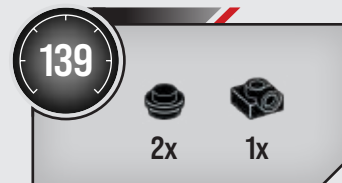
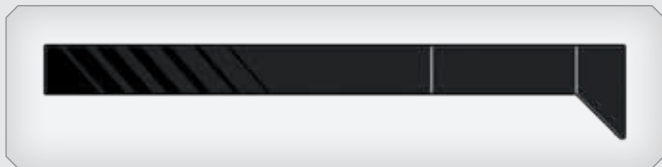
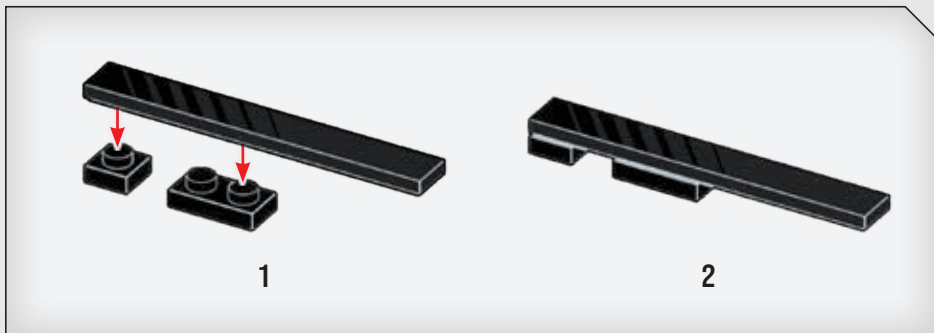
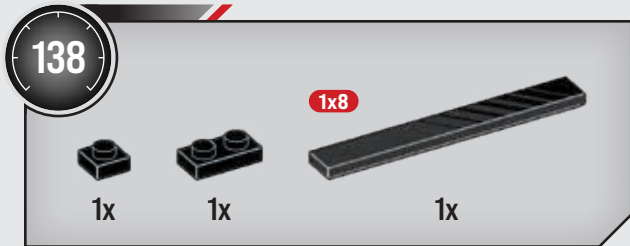

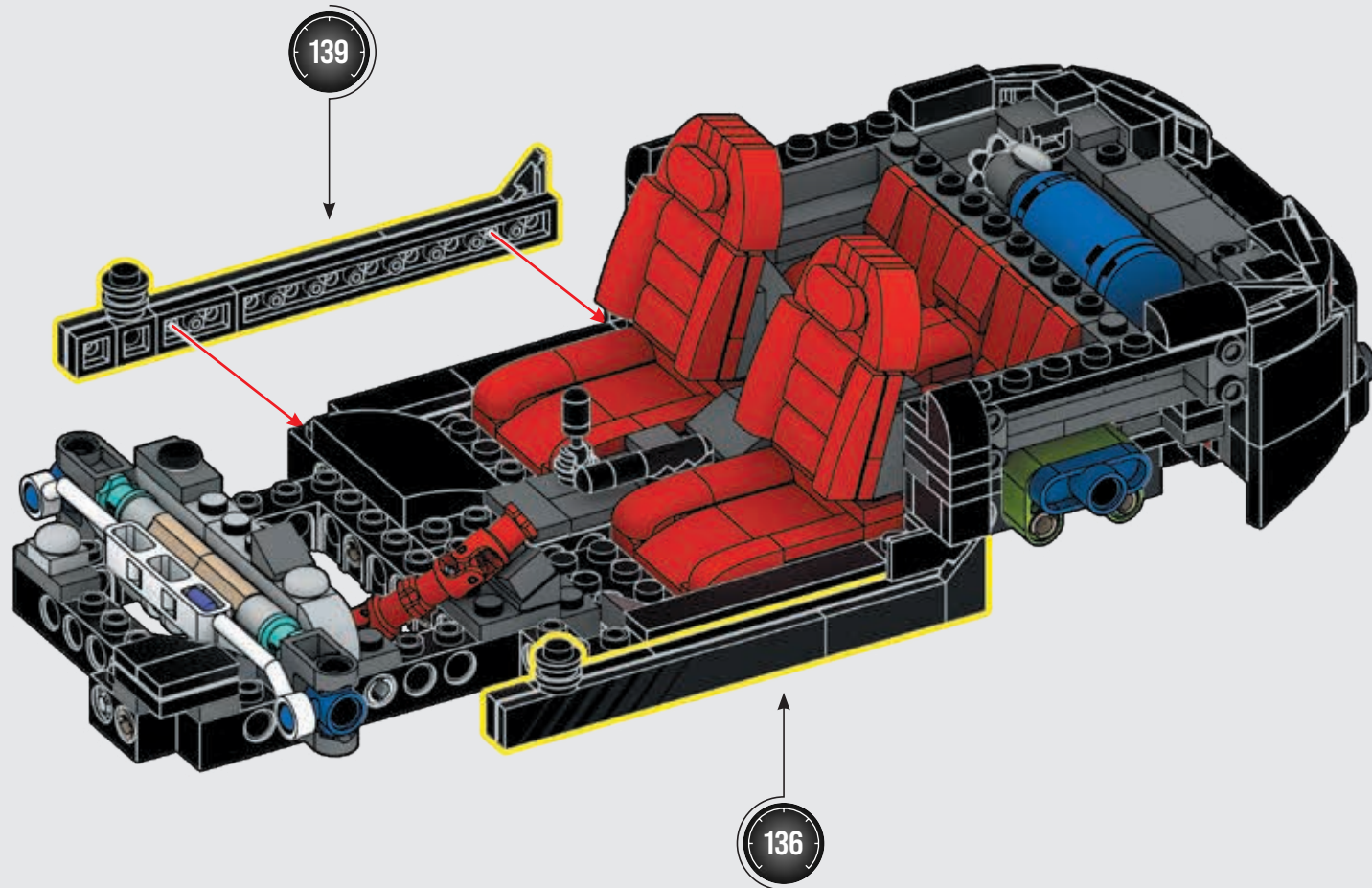

143



1x 1x 1x 1x

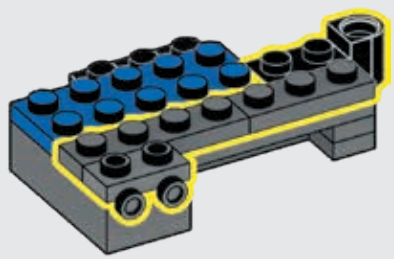

144



1x 1x

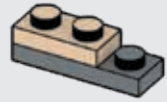

145



1x 1x 1x

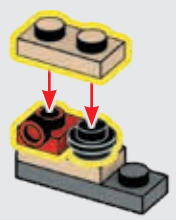

146



1x 1x 1x

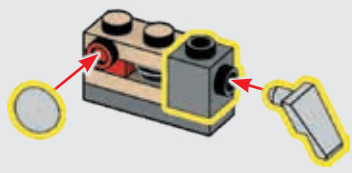

147



1x 1x 1x

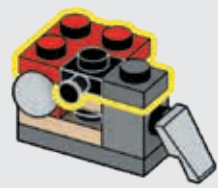

148

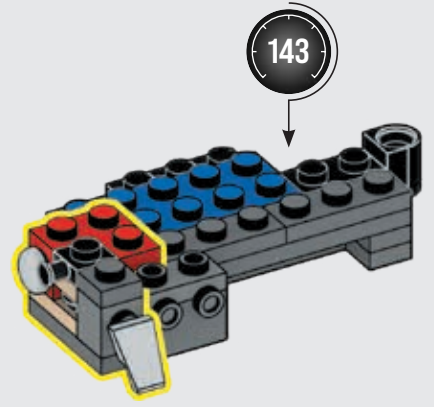

149

1x 1x 1x6

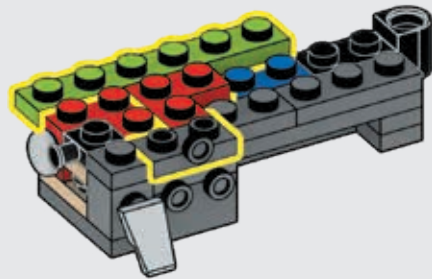

150

1x 1x 1x

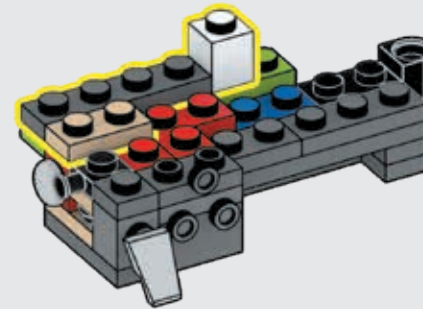

151

1x 1x 1x

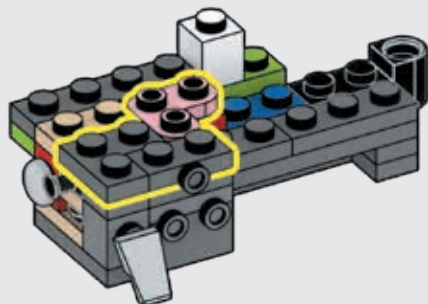

152

1x 1x 1x 2x 1x

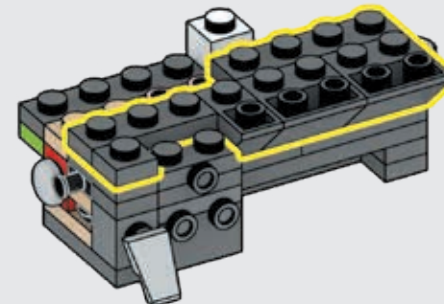

153



1x

1x

1x

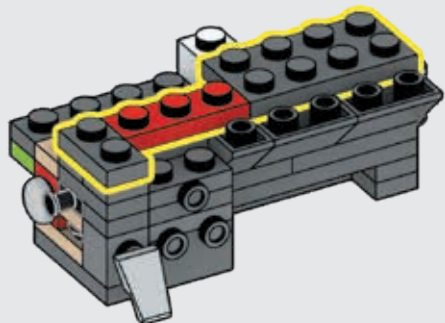

154



1x

1x

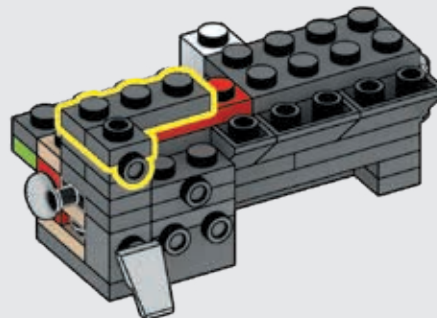

155

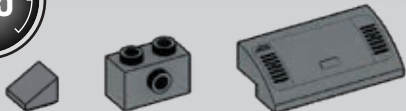

1x

1x

1x

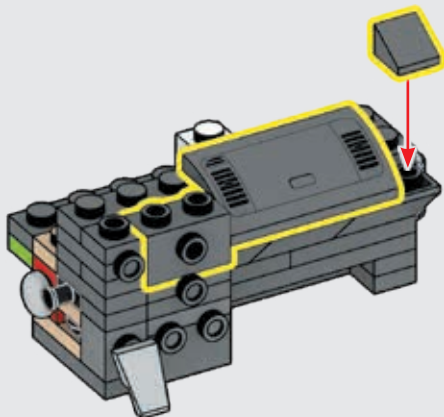

156

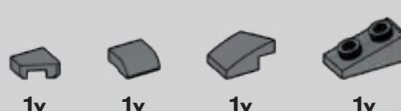

1x

1x

1x

1x

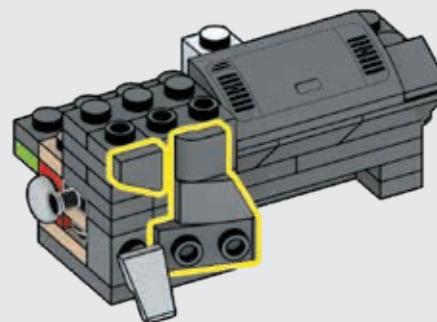

157

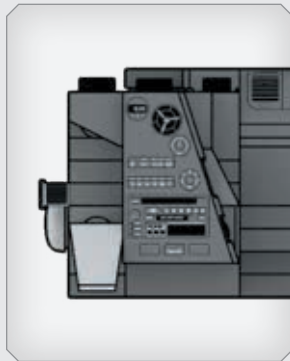
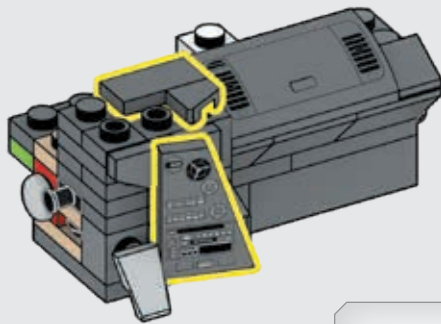
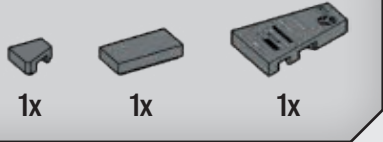

158

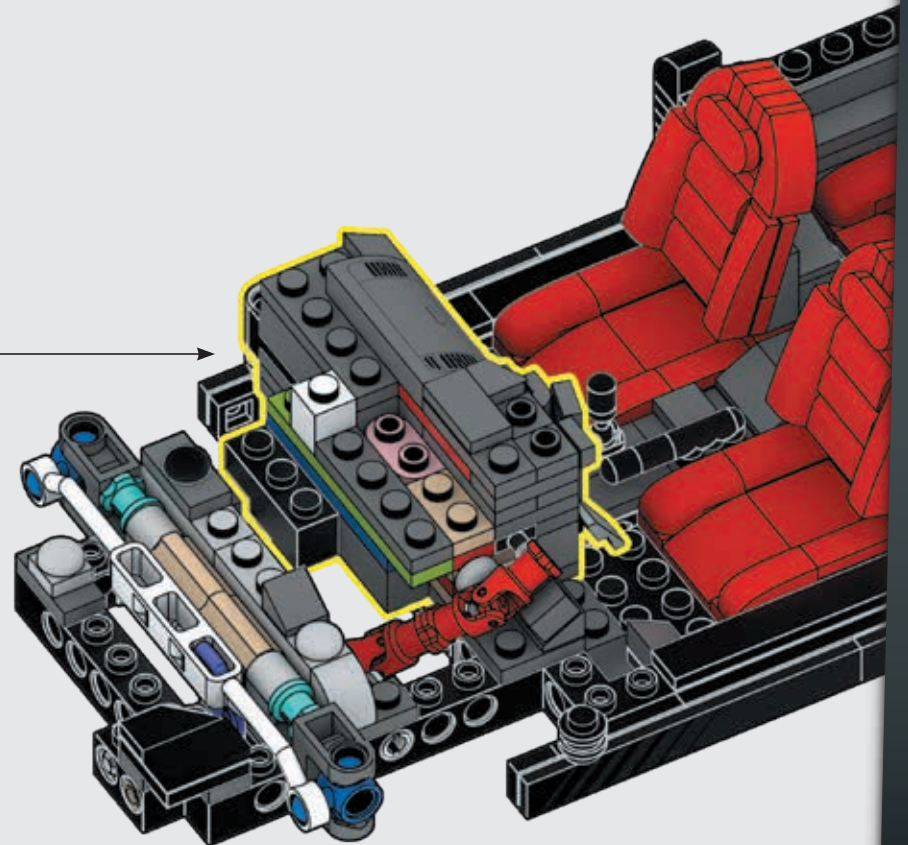

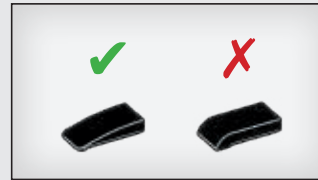
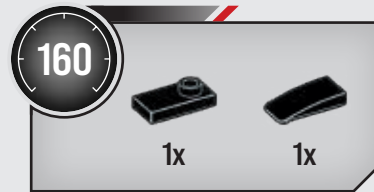
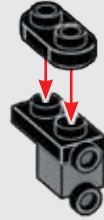
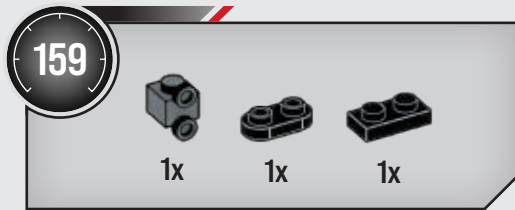

1



2

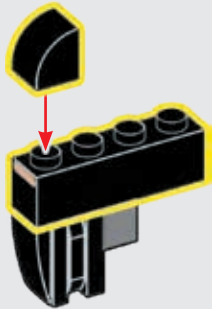
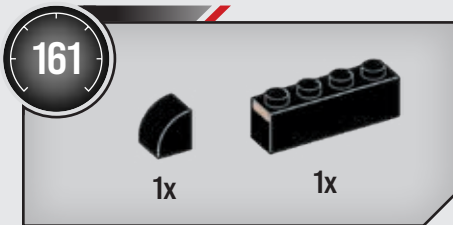

1

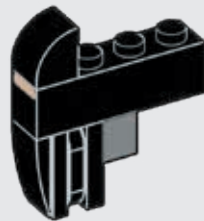

2

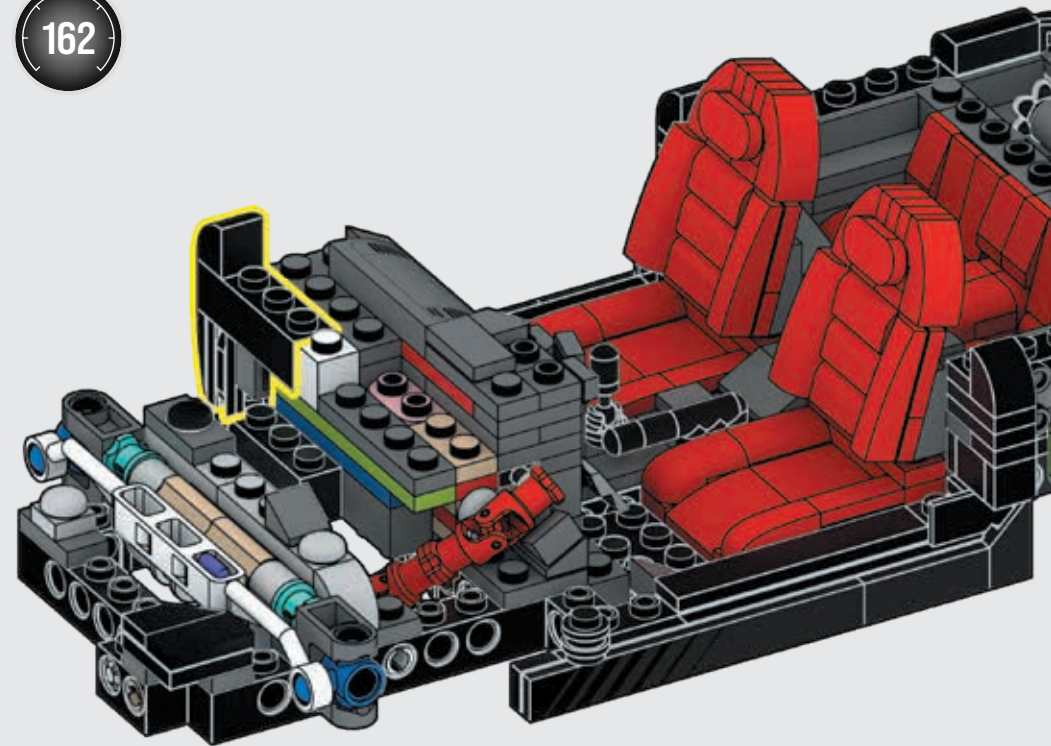

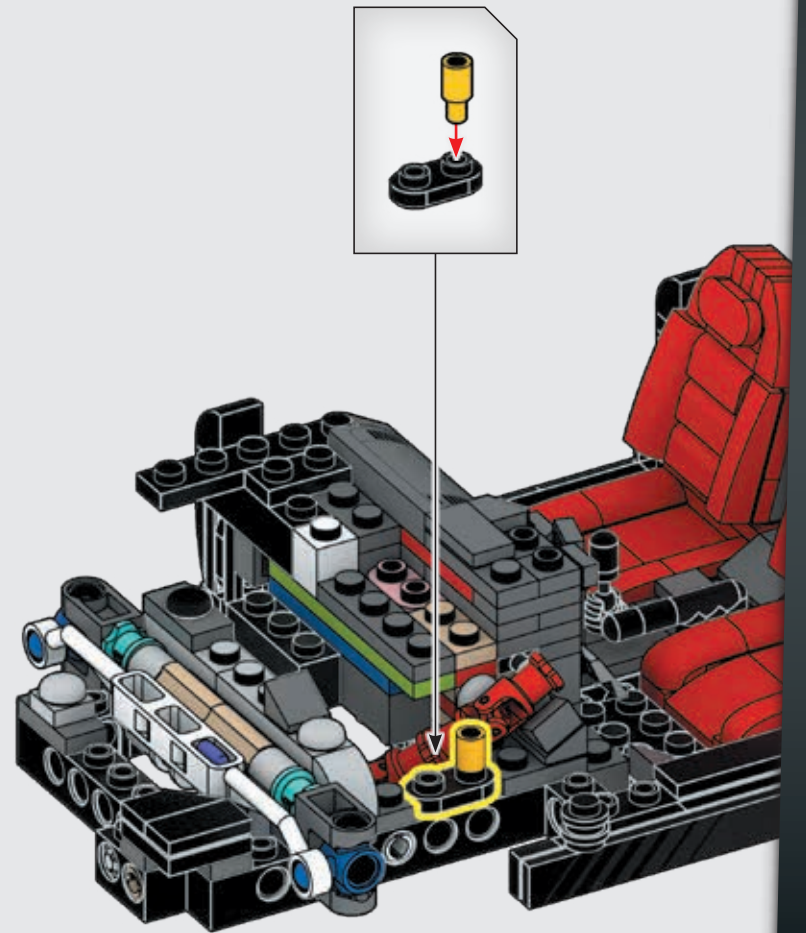
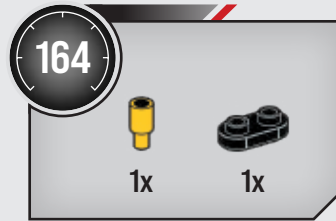
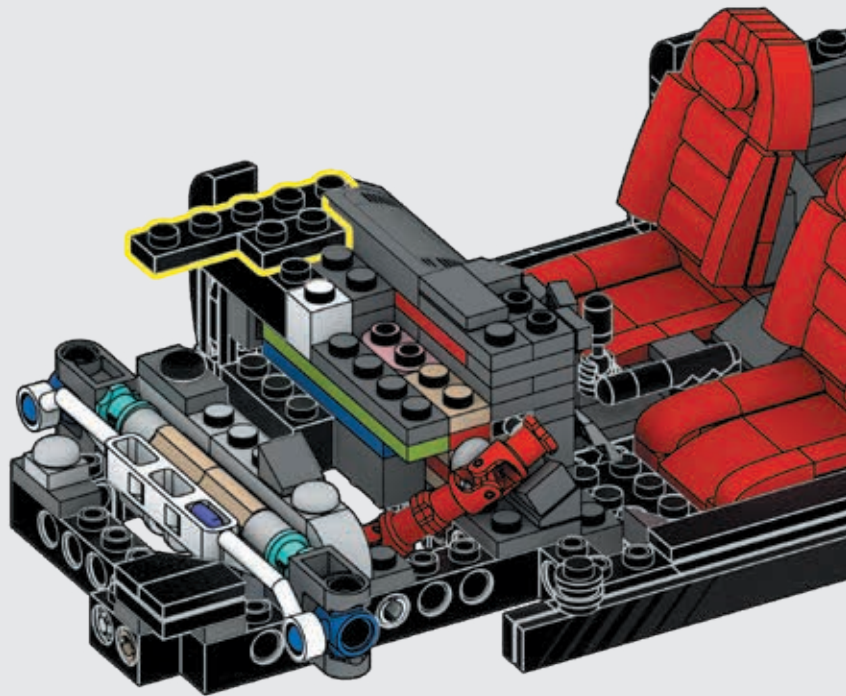
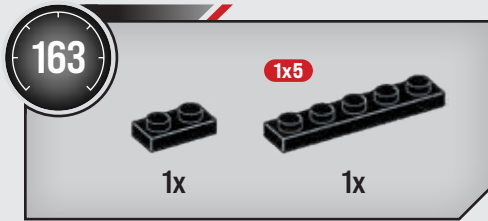

165

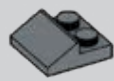

1x



1x

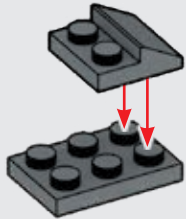

166



1x

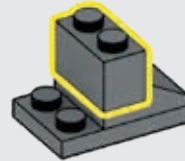

167



1x



2x



1x



1

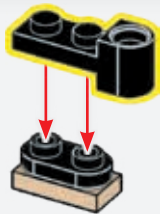

2

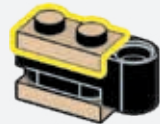

3

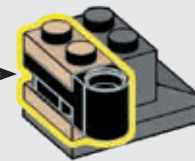

168



1x



1x

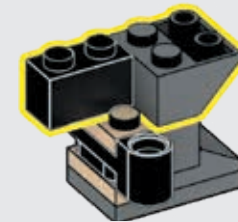

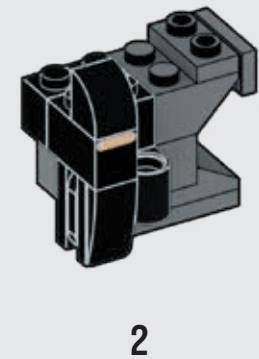
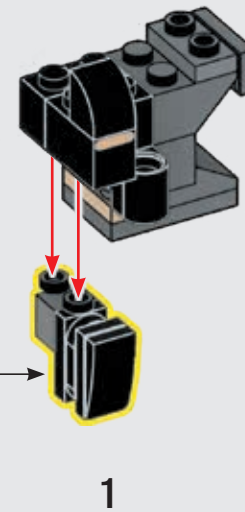
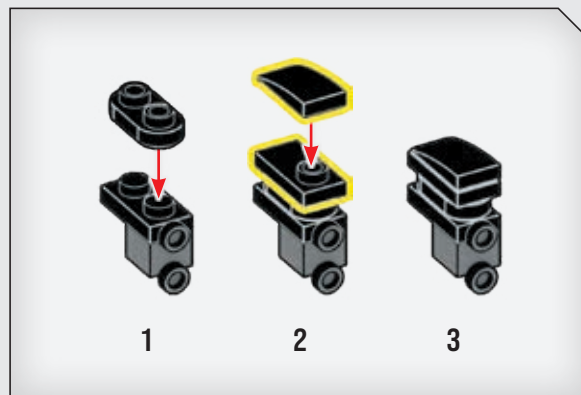
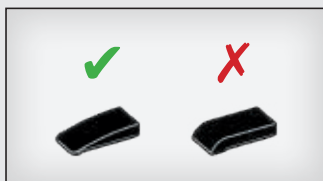
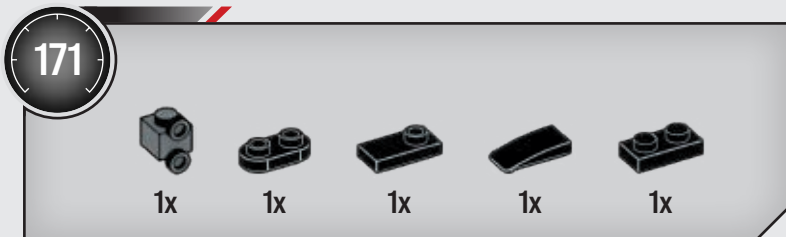
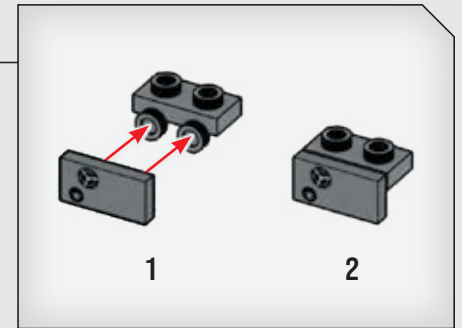
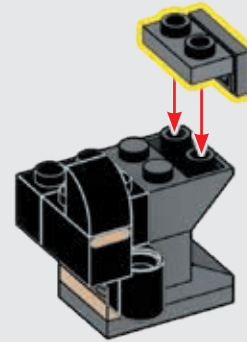
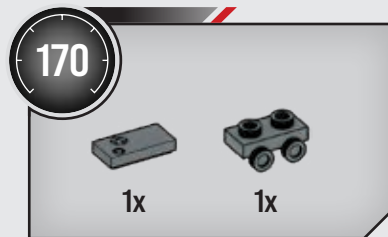
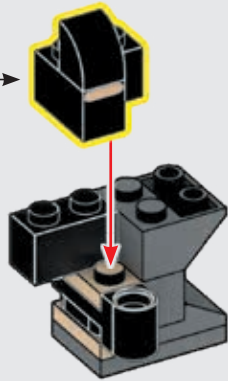
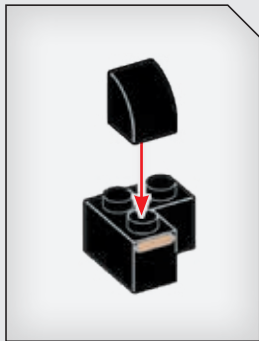
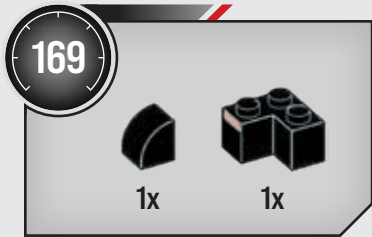

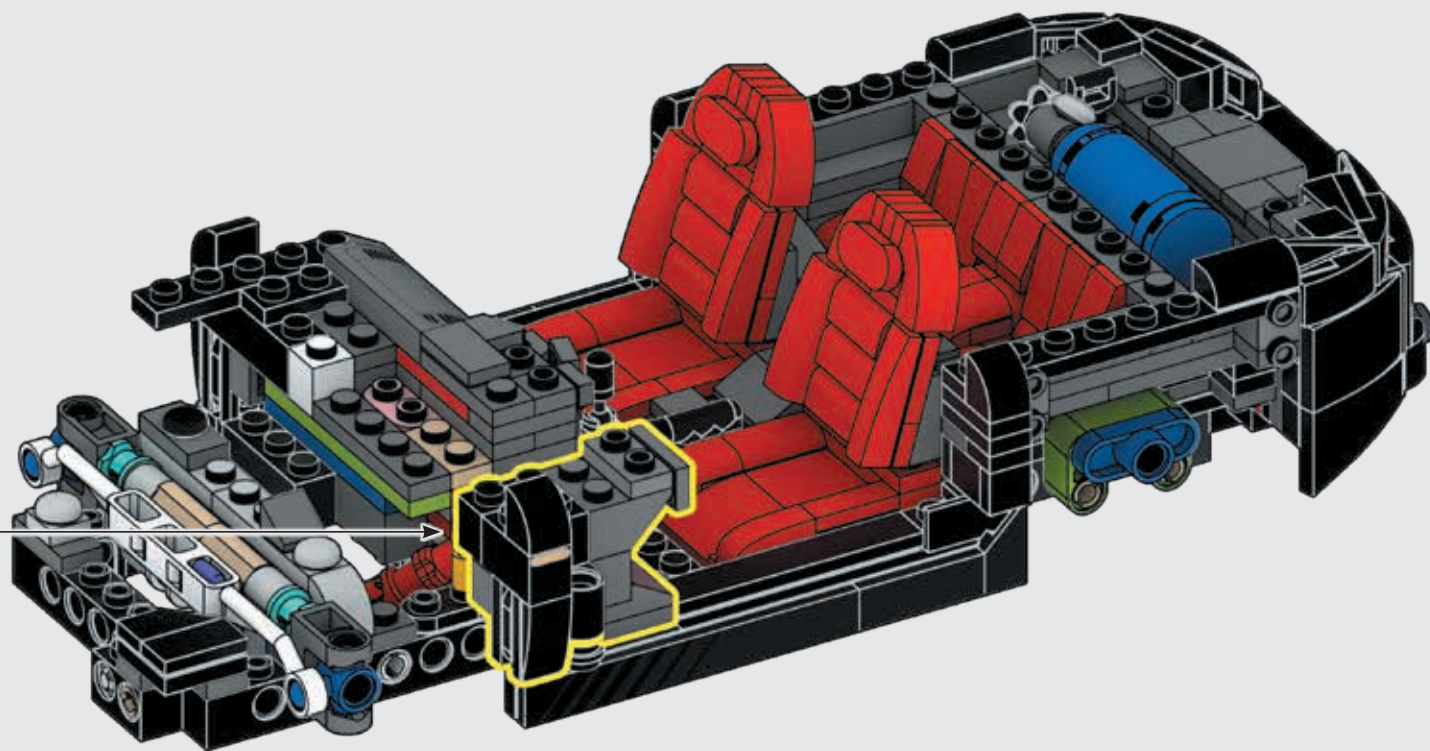

173



1x

1x5



1x

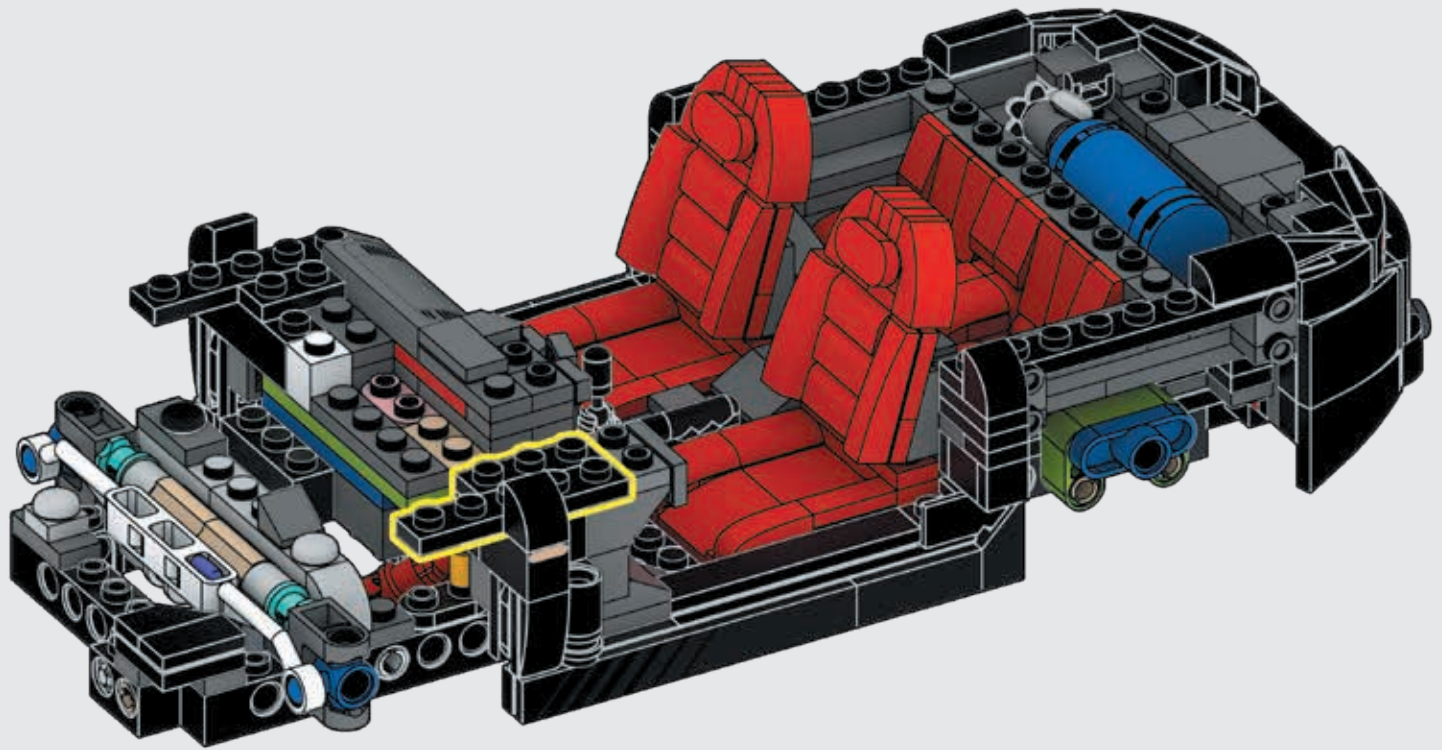

174

2x 1x

175

1x

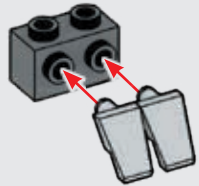

1

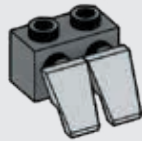

2

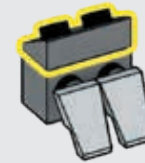

176

1x

177

1x 1x 1x

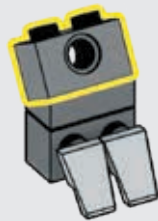

1

2

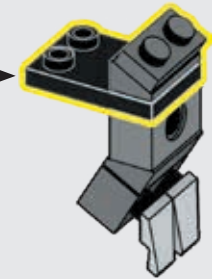

178

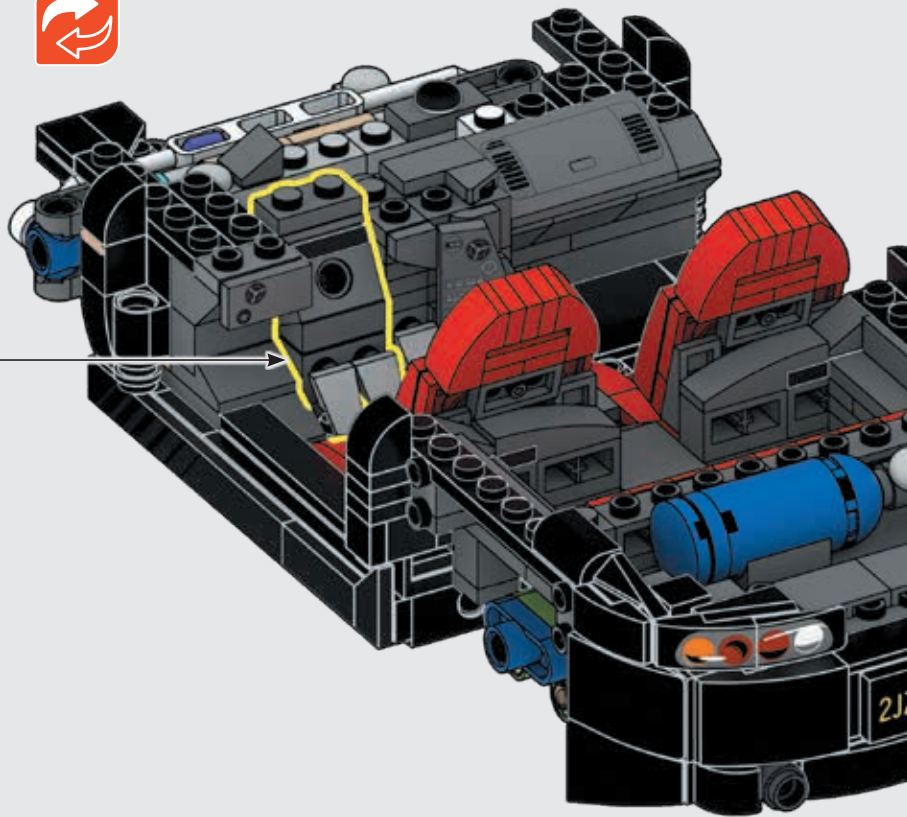

179



2x

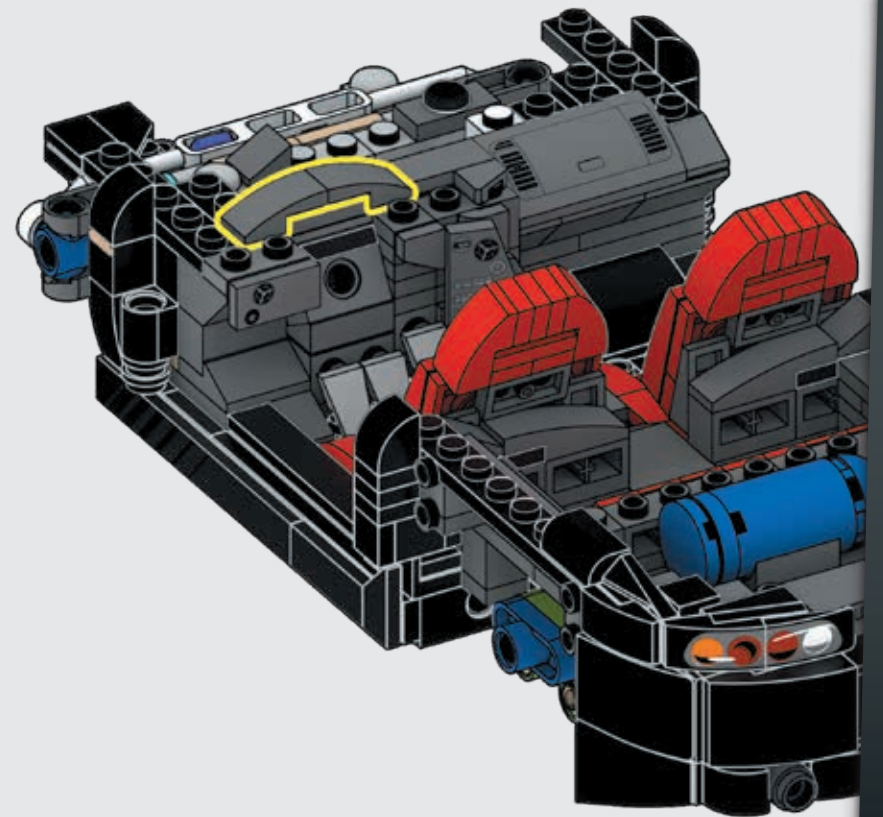

180

1x

1x

1x

1x

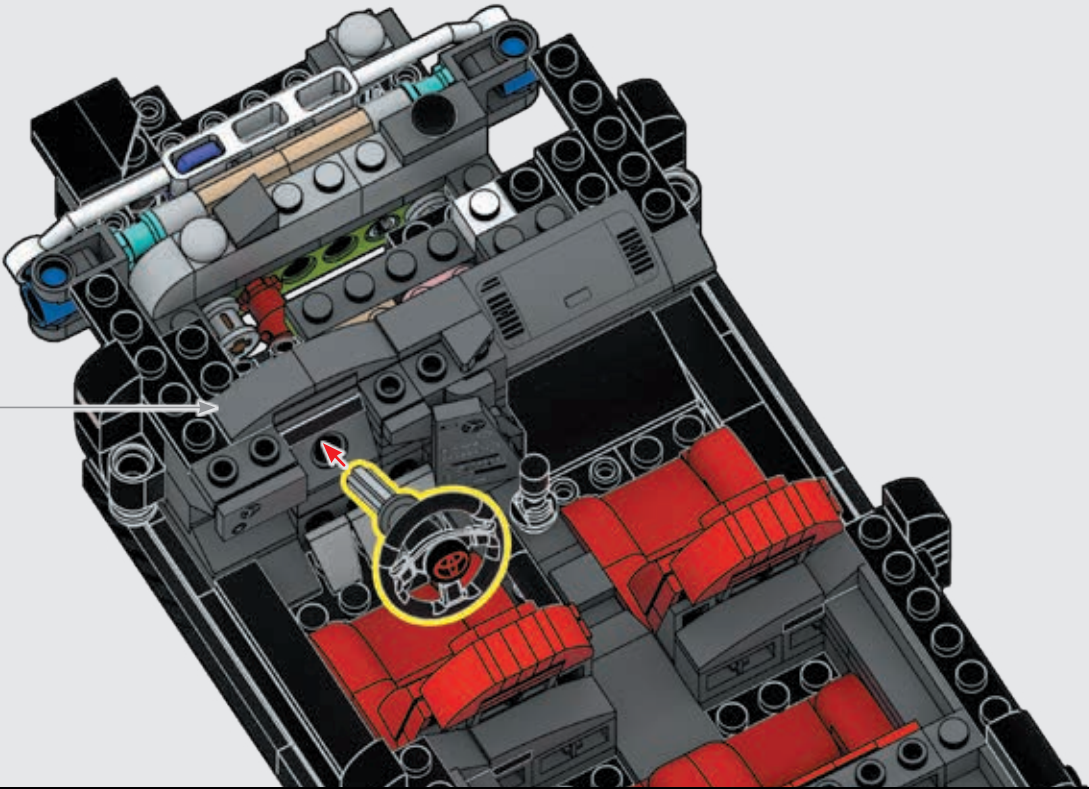
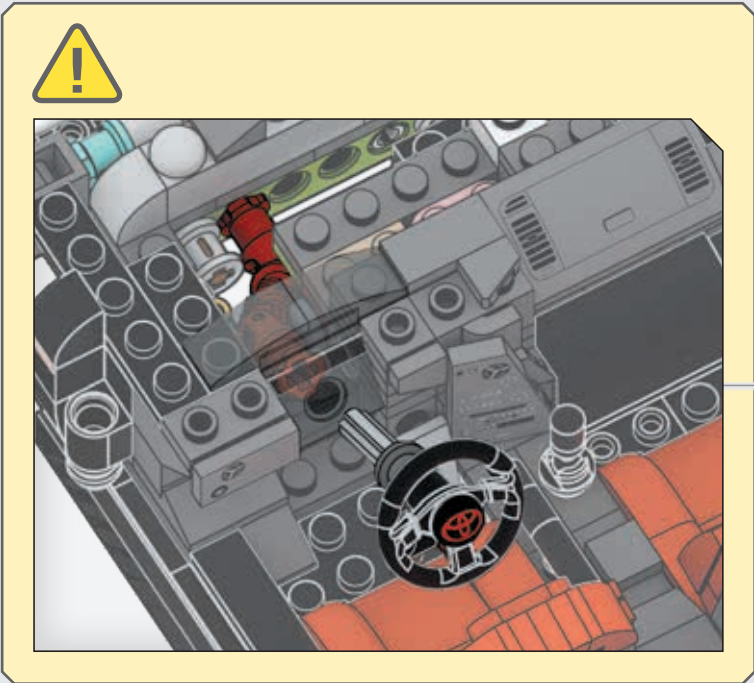
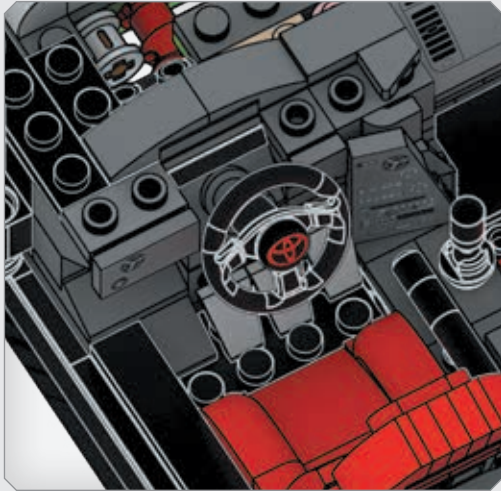
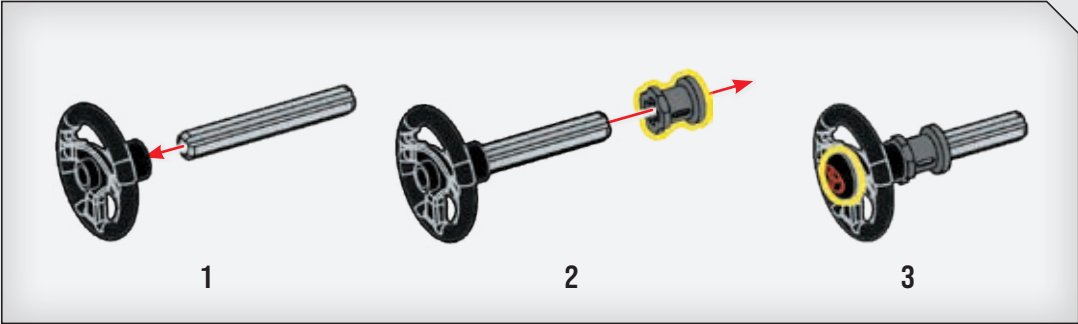

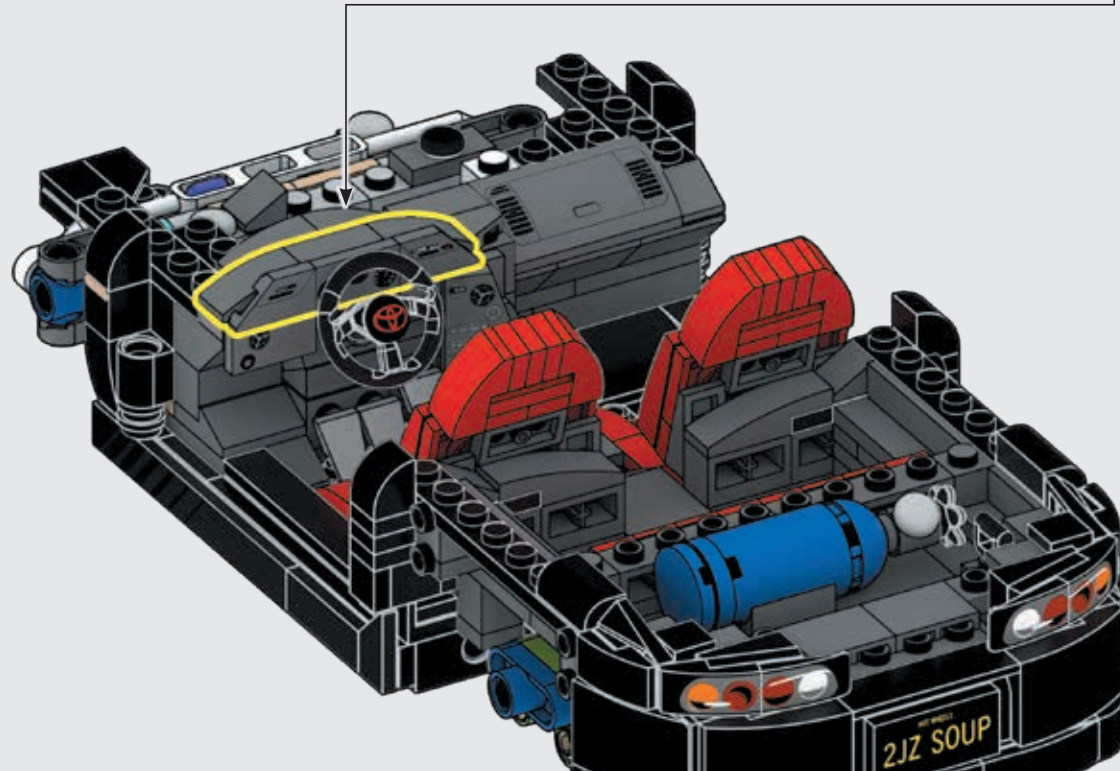
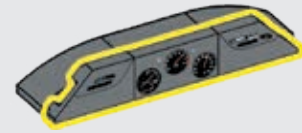
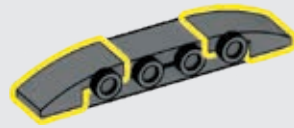
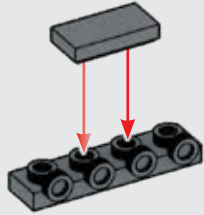
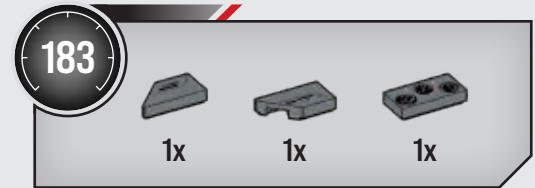
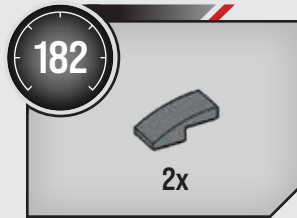
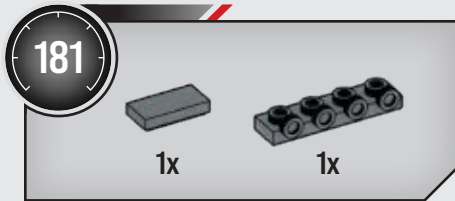

185

1x 1x



186

1x 1x

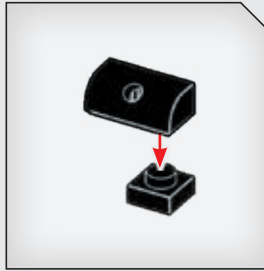

187

1x 1x

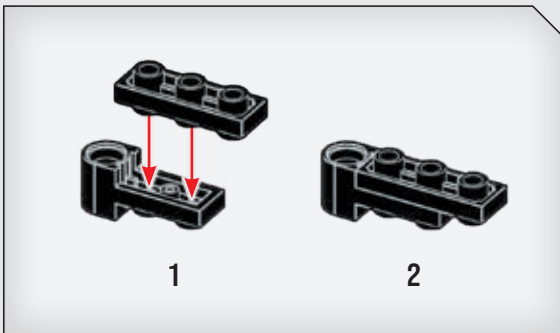

188

1x 1x5

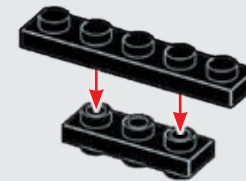

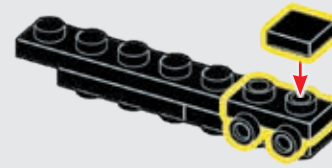
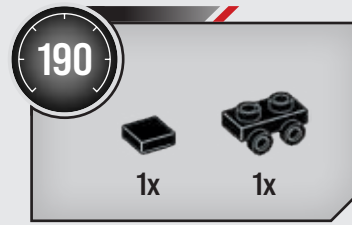
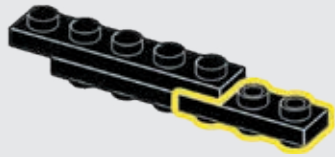

1

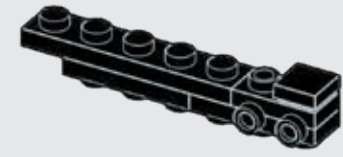

2

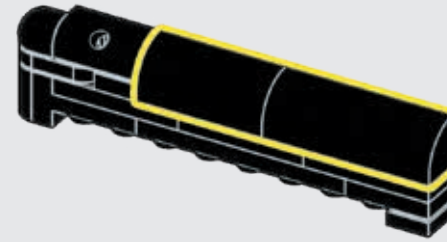
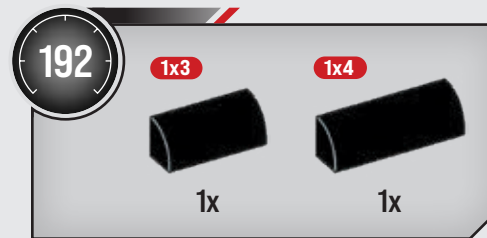
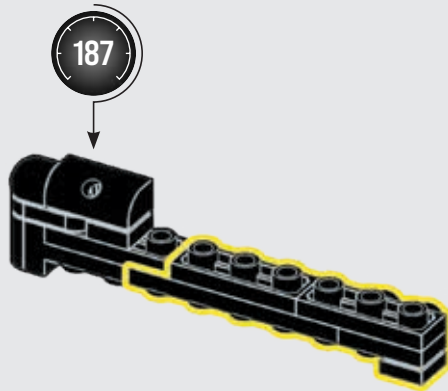

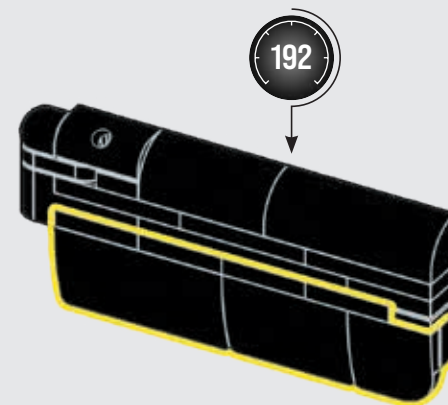
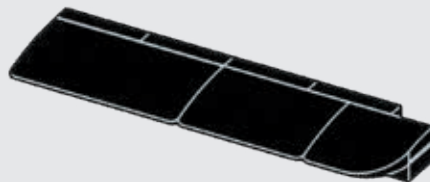
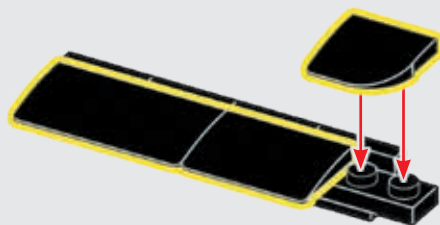
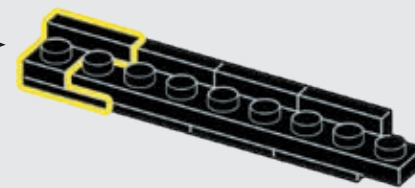
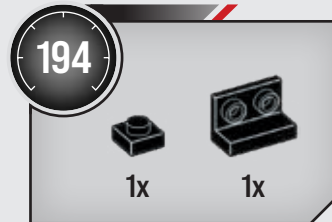
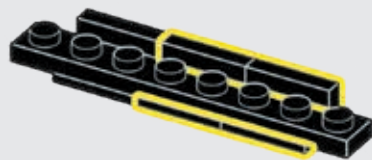
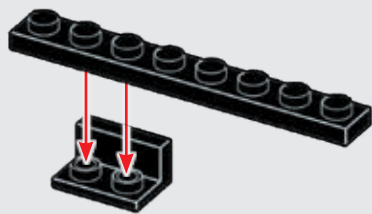
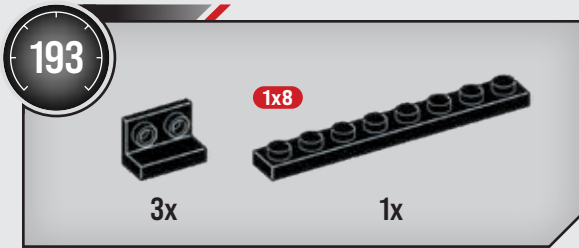

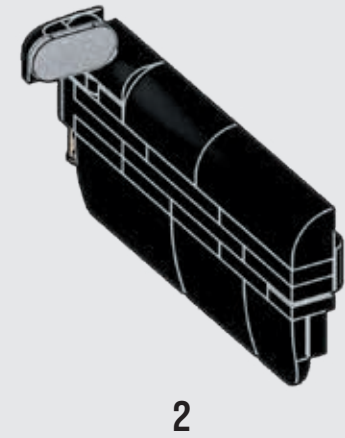
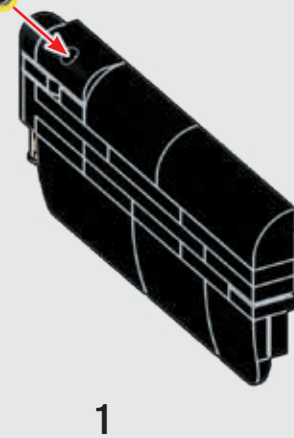
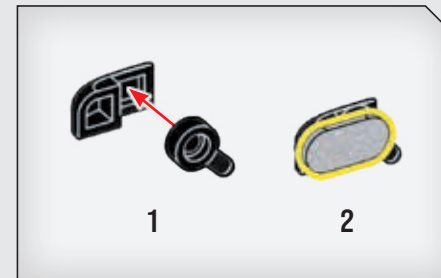
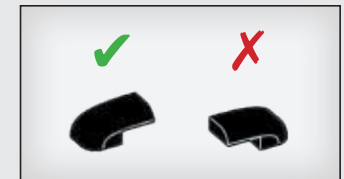
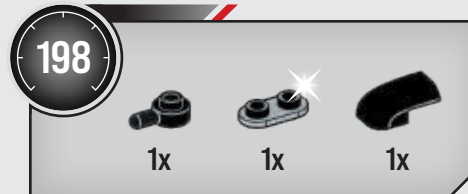
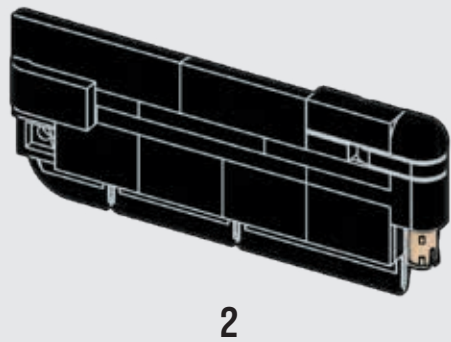
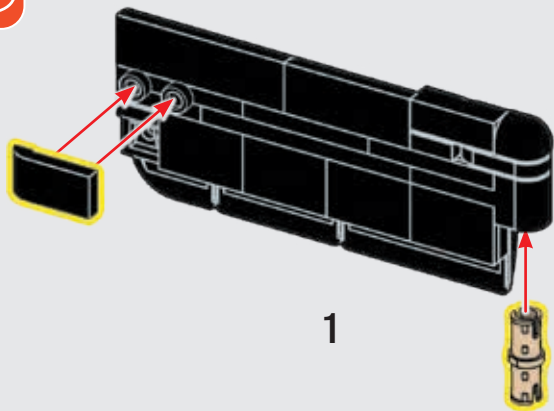
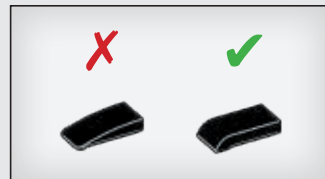

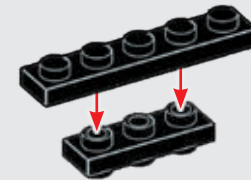
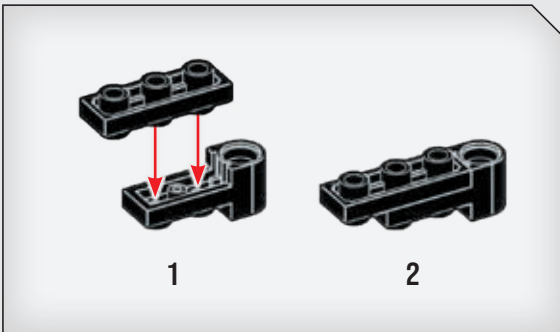
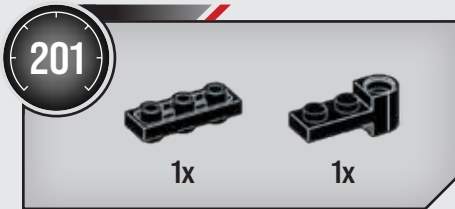
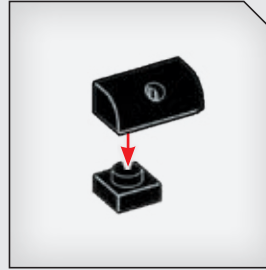
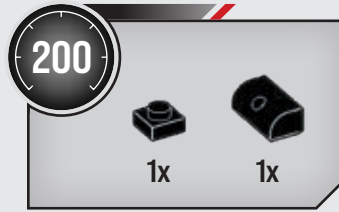
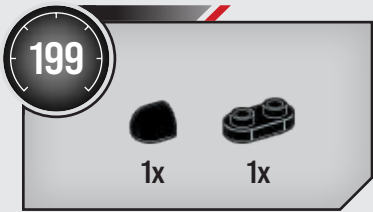

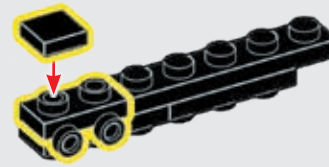
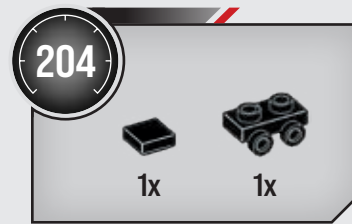
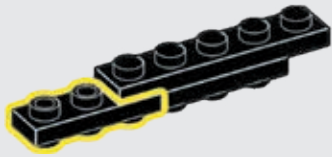
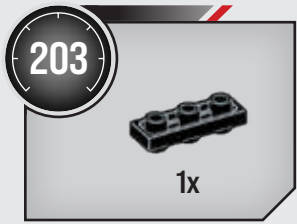

1

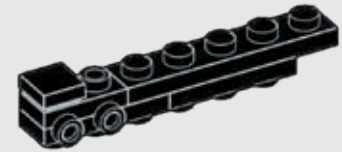

2

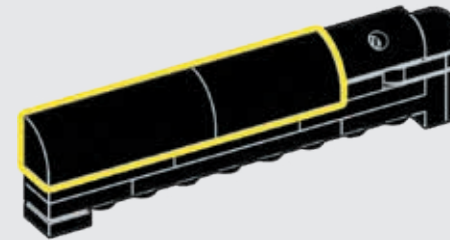
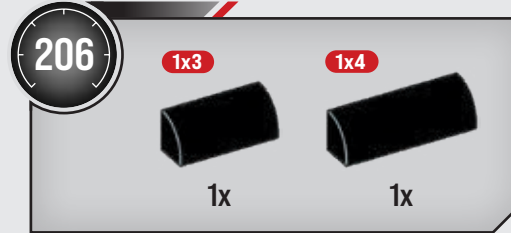
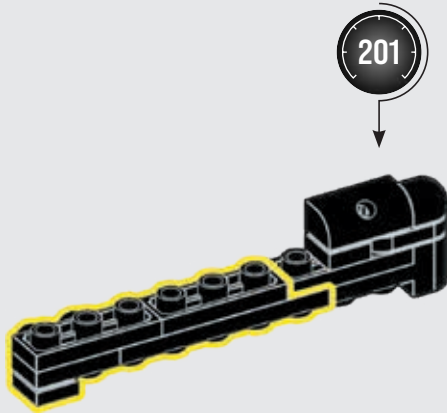

207

3x **1x8**

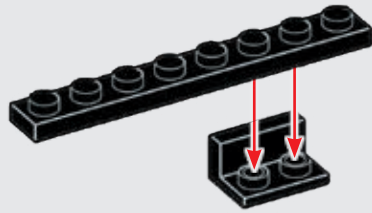

1



2

208

1x 1x

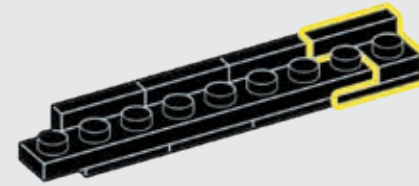
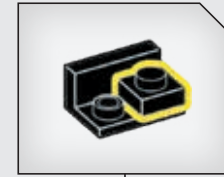

209

1x **2x3** **2x4**

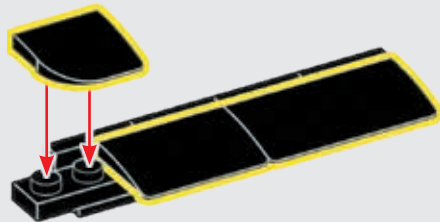

1

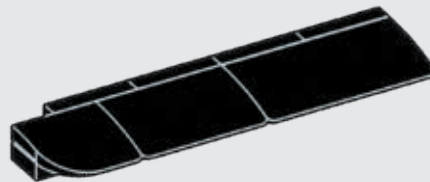

2

210

206

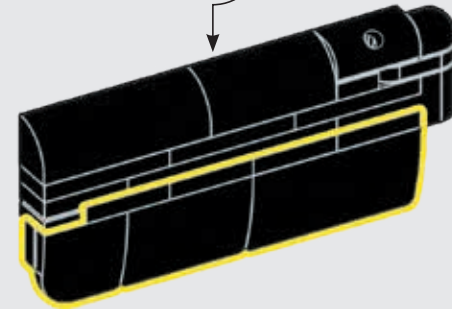

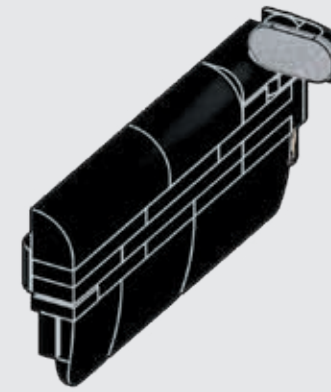
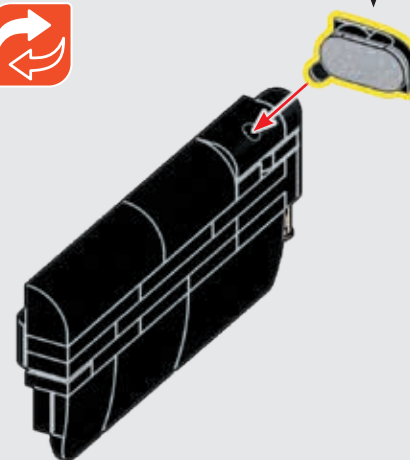
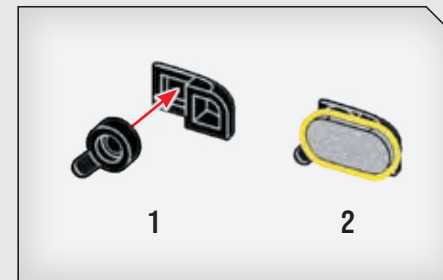
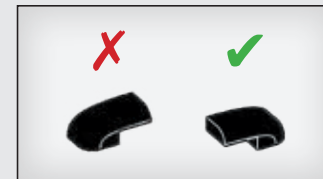
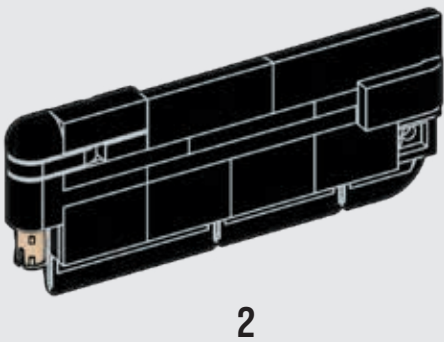
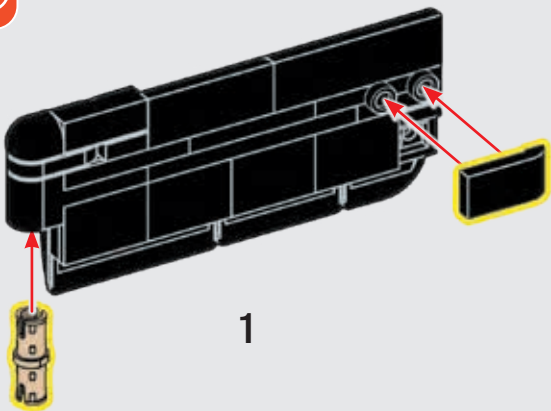
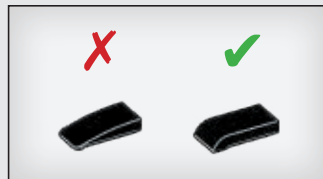

213

198

212

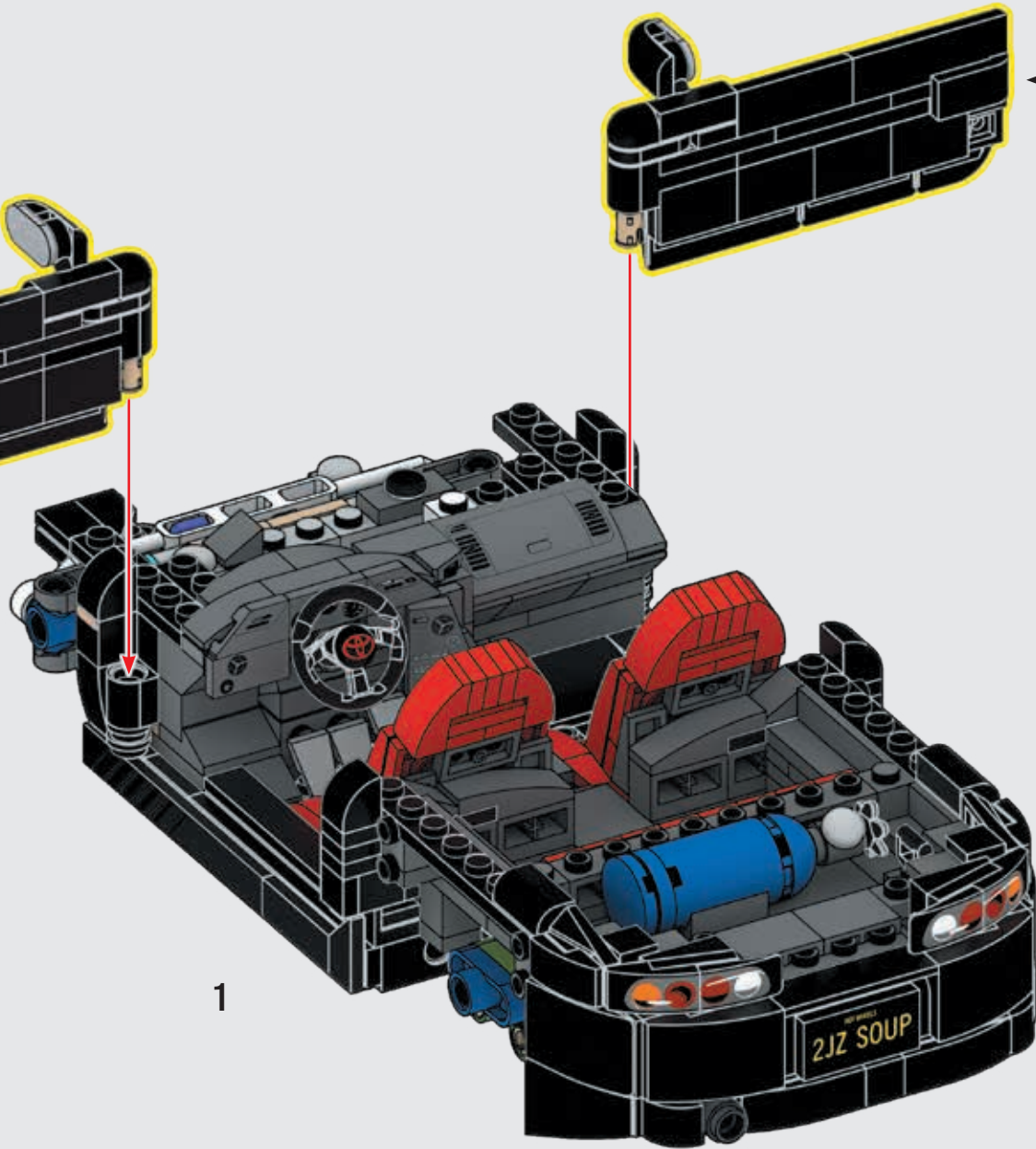

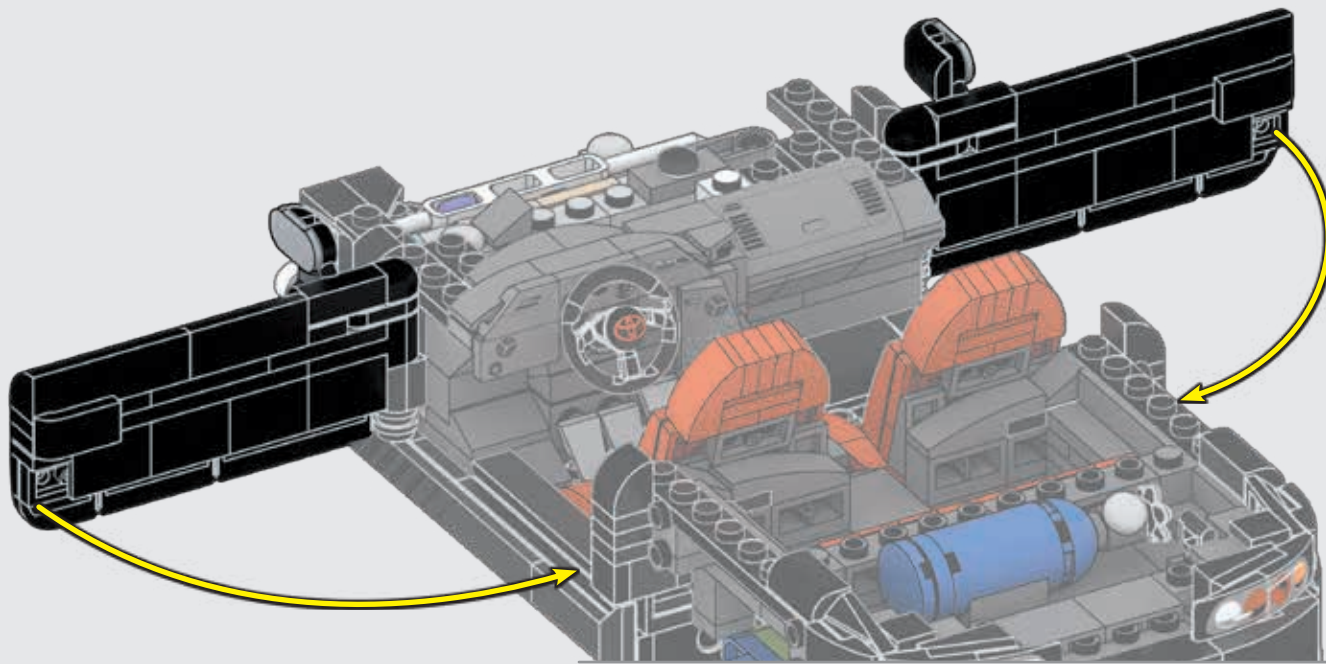

2

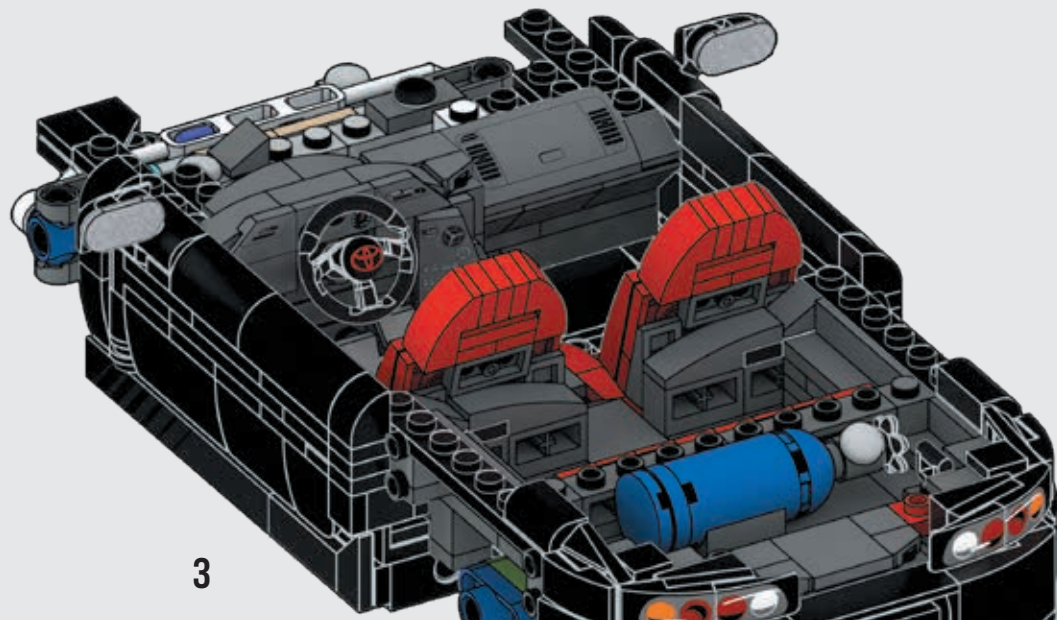

3

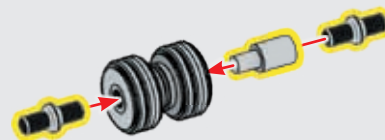
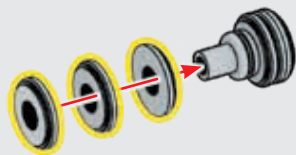
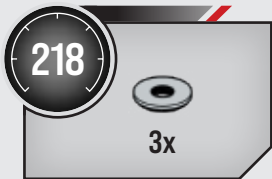
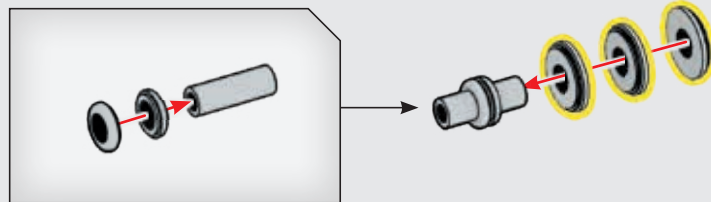
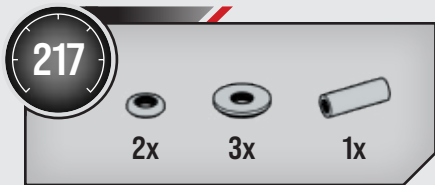

220



1x



1x



1x

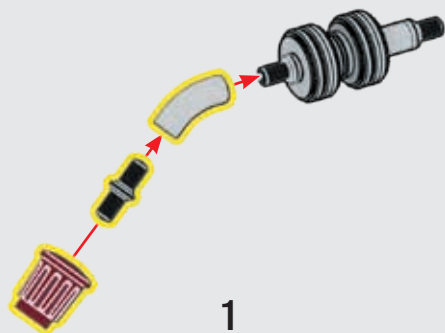

1

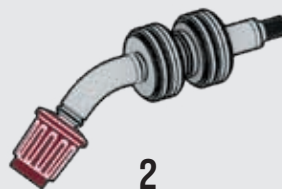

2

221

216

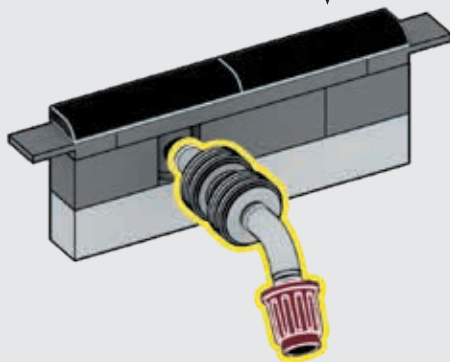

1

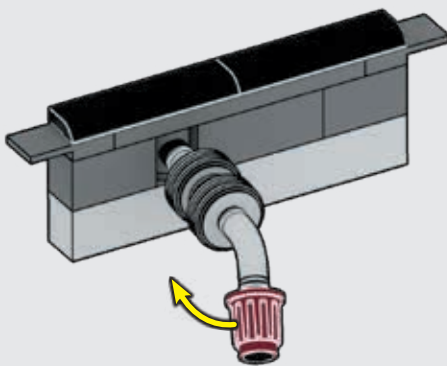

2

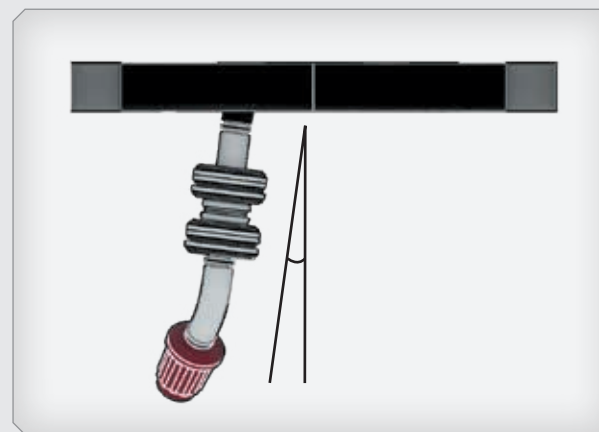

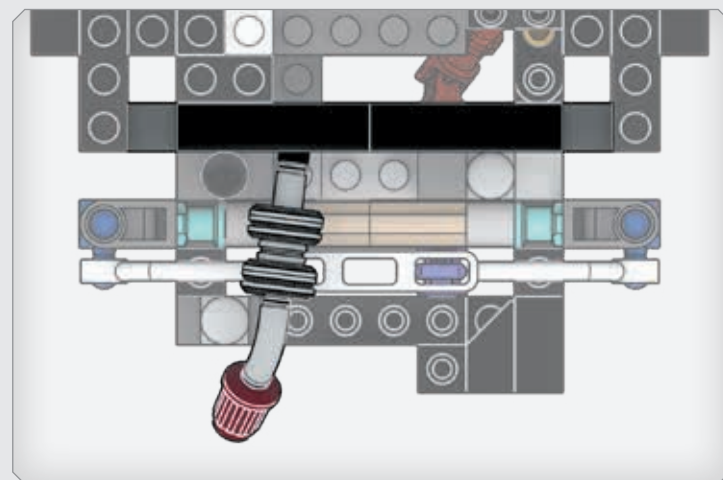
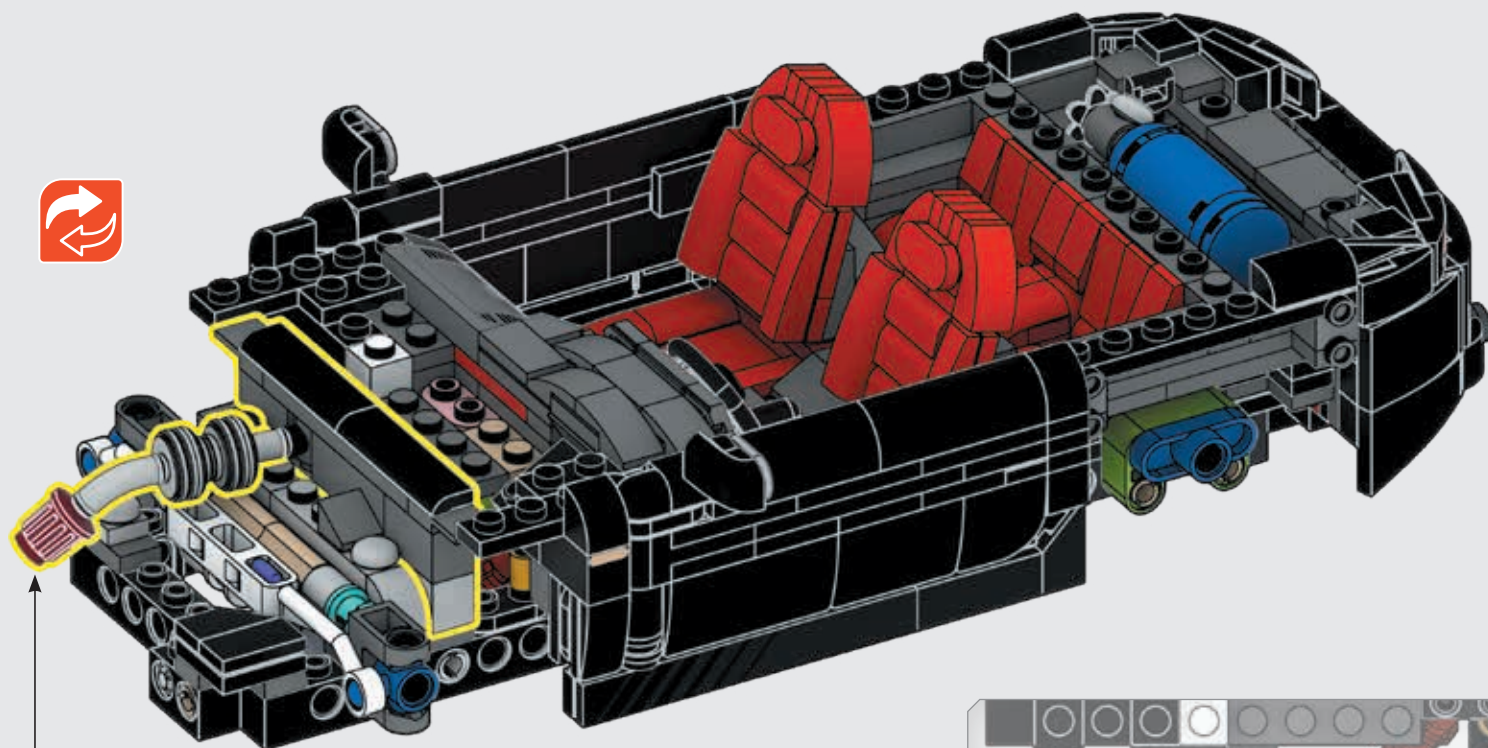

223



2x

1x

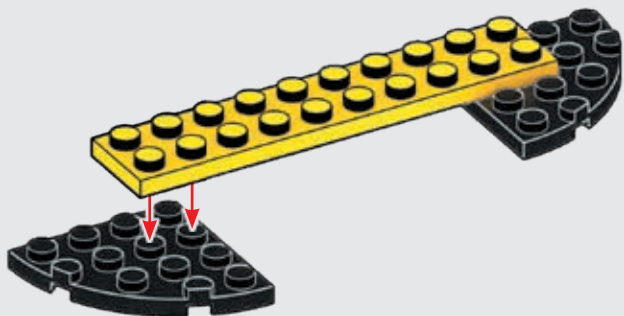

224



3x

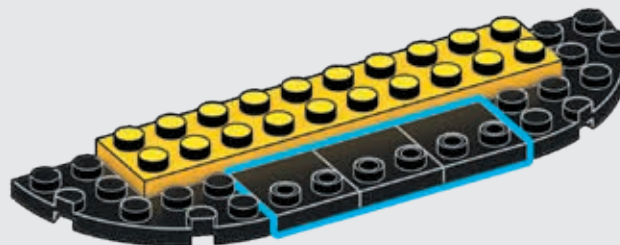

225



1x



1x

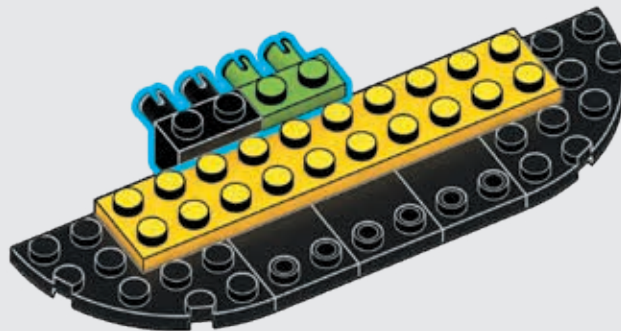

226

1x 1x 1x 1x 2x

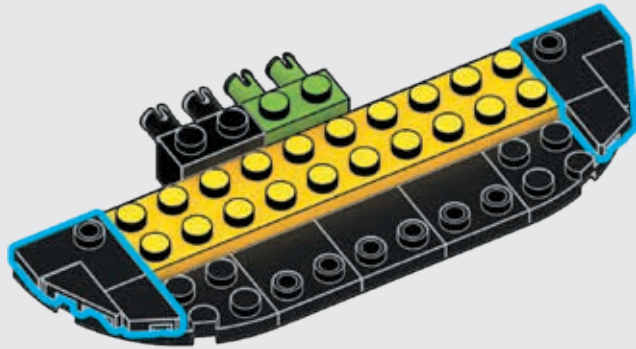

227

2x 1x6 1x

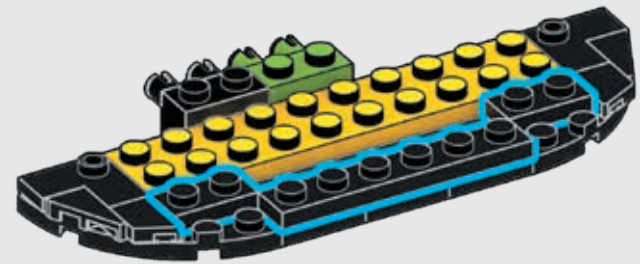

228

2x 1x 1x

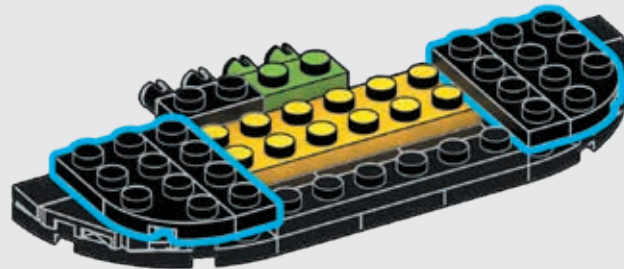

229



2x

1x4



1x

2x6

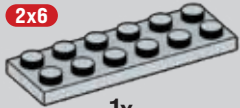

1x

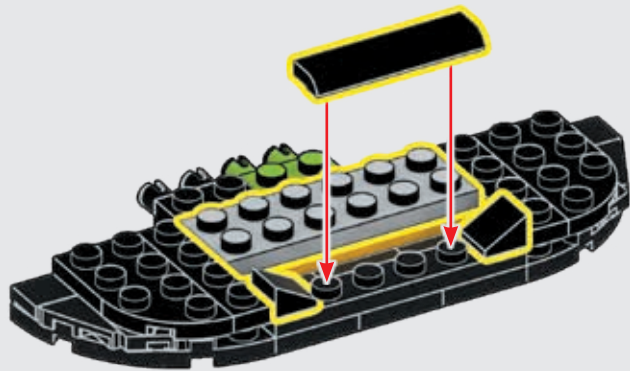

230



2x



2x



2x



1



2



1



2



231



2x



1x



1x

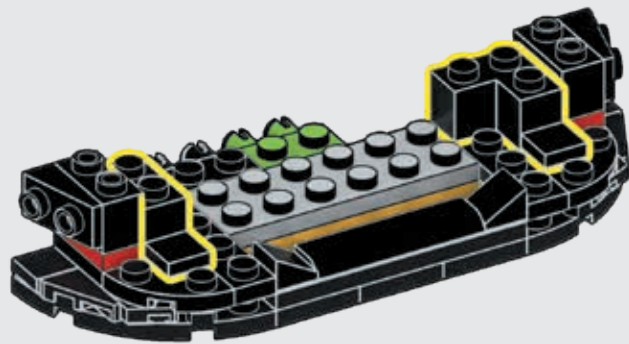

232



9x

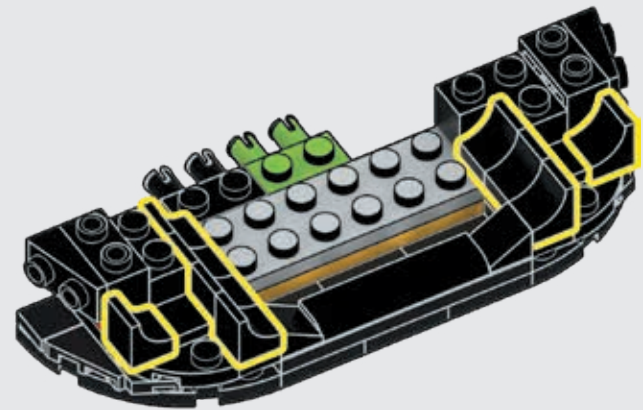

233



2x



1x



2x

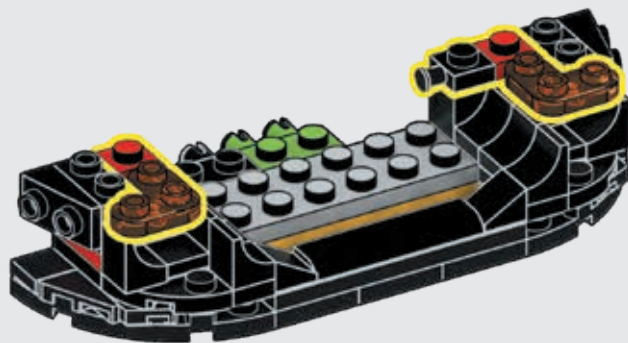

234



2x

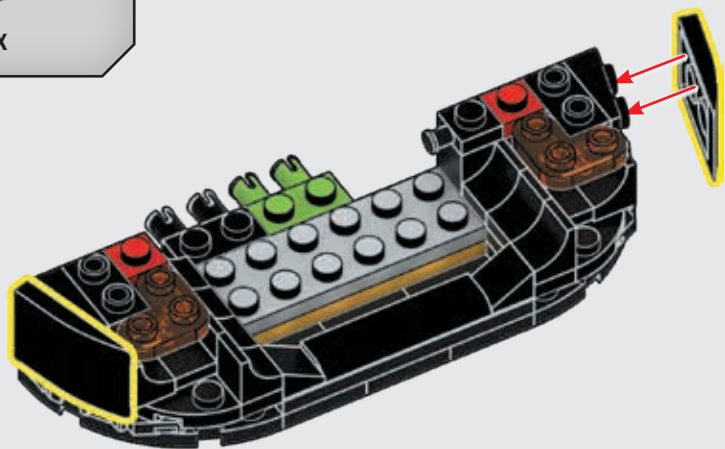

1

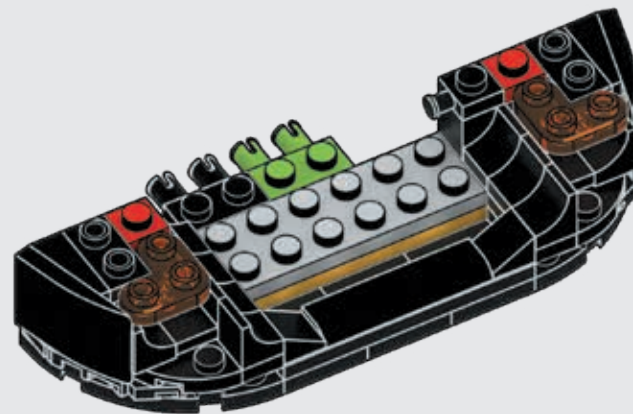

2

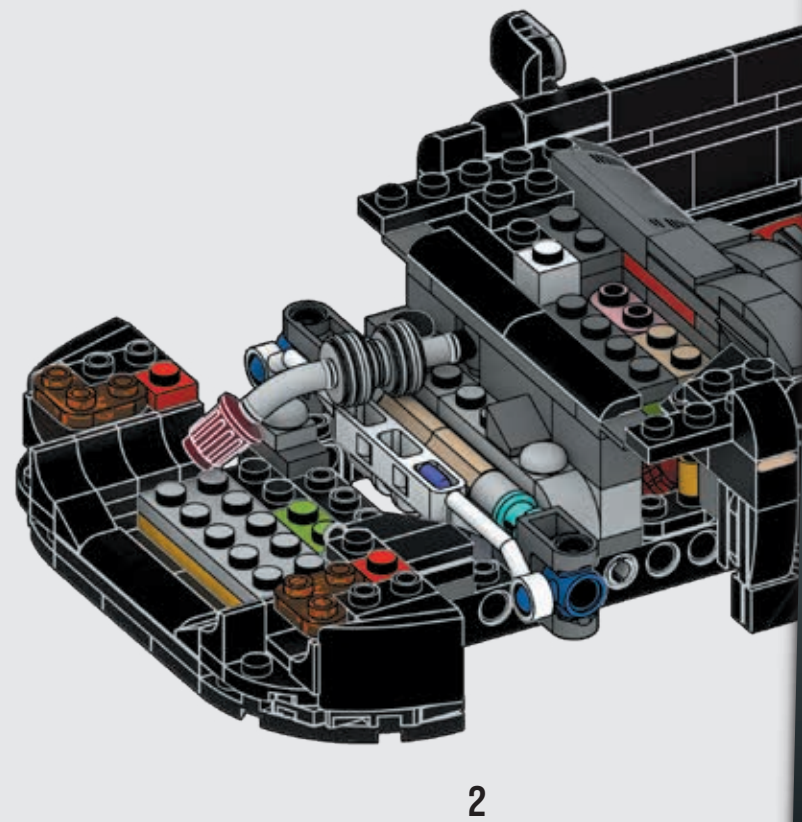
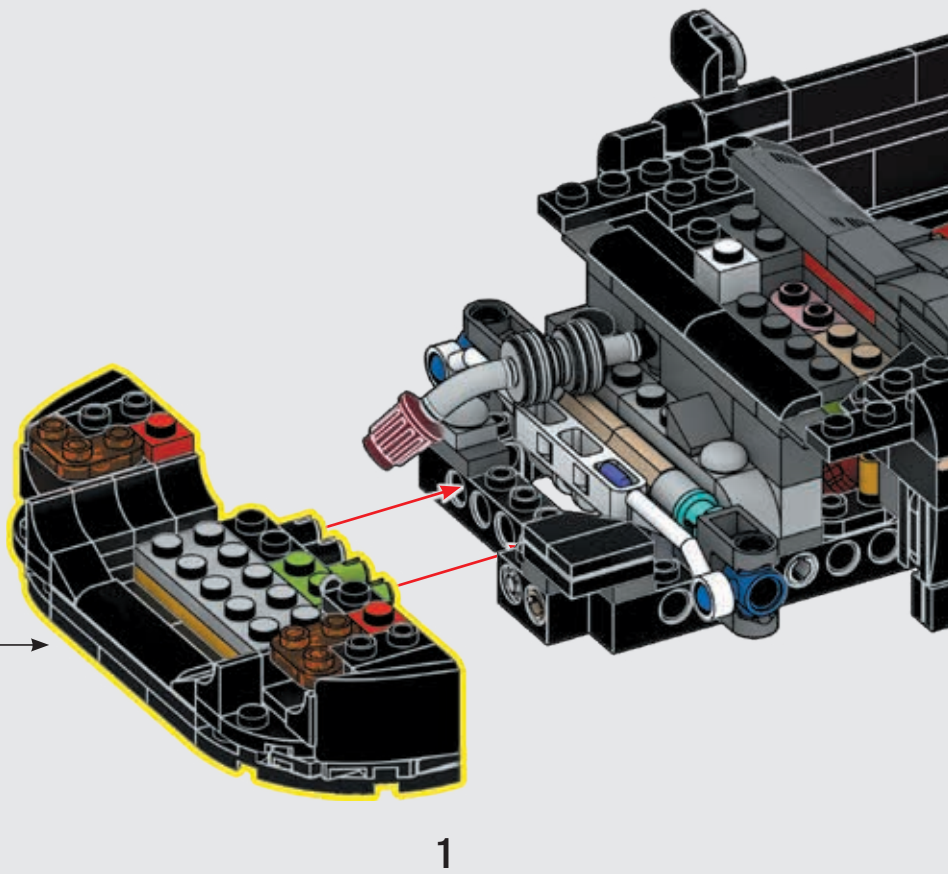

236

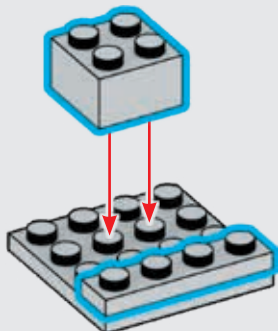
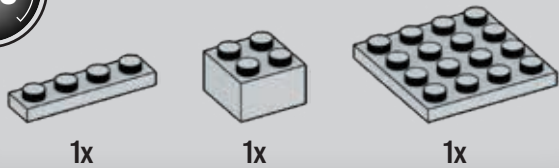

237

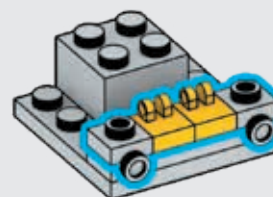

238

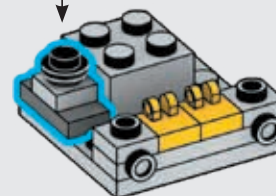
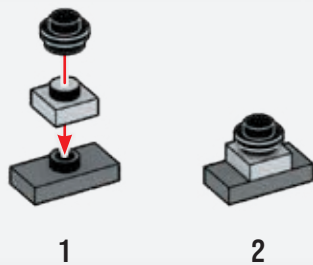

239



1x



1x



1x



1x

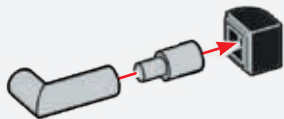

1

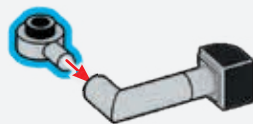

2

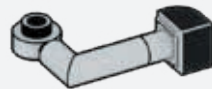

3

1:1

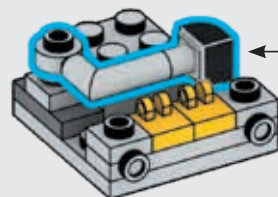
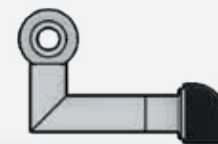
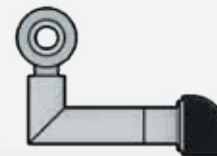

1

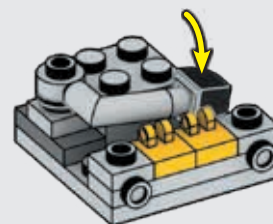

2

240



1x



1x

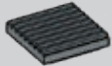

2x



1x

1x6



1x

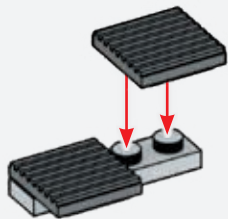

1

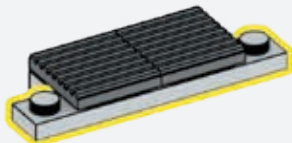

2

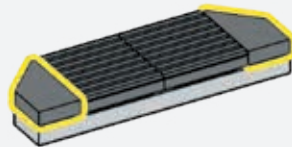

3

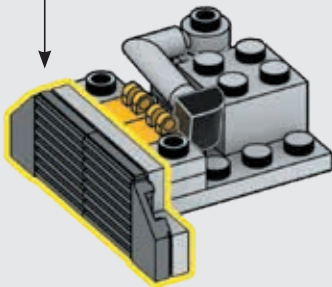

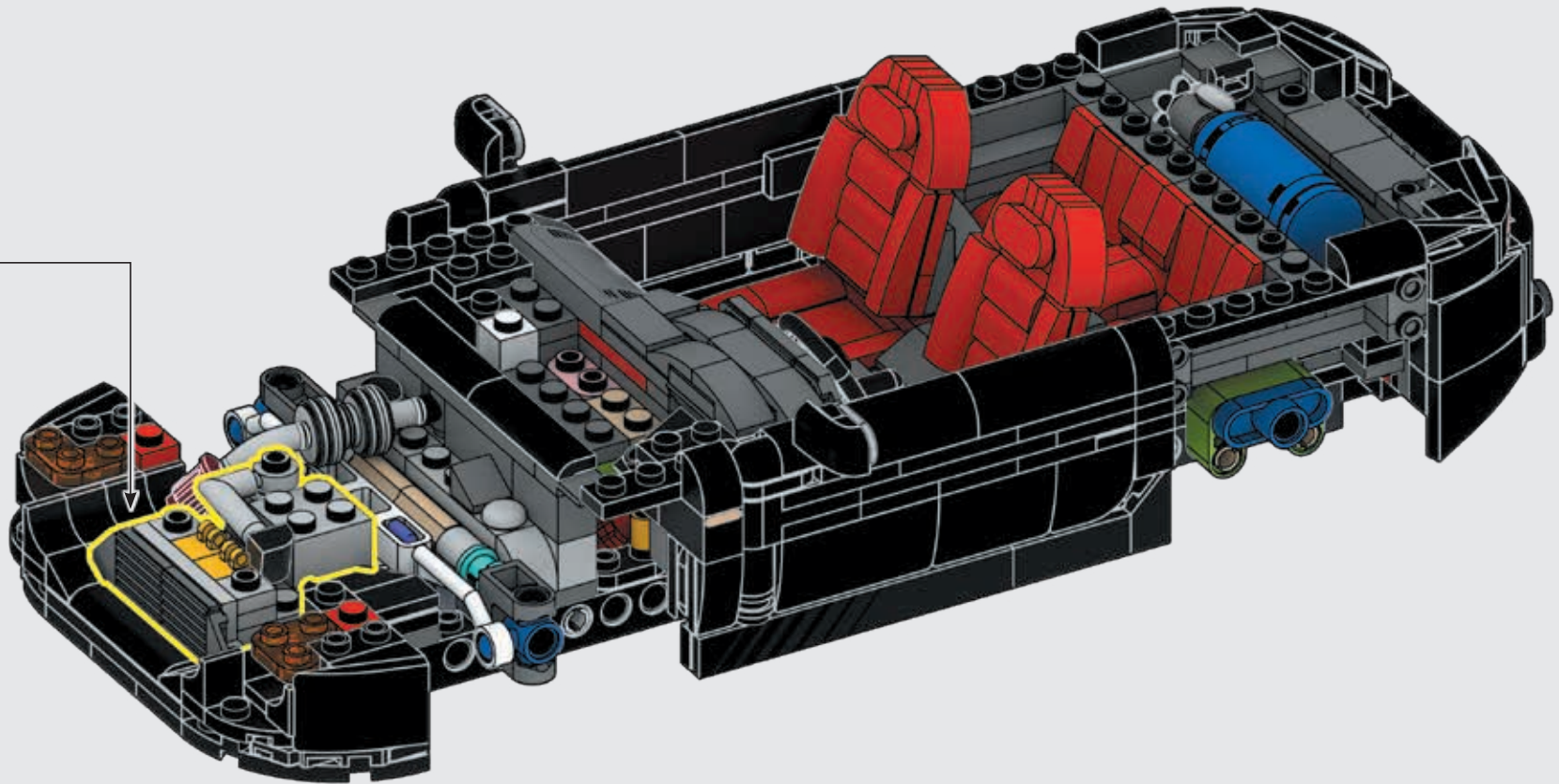
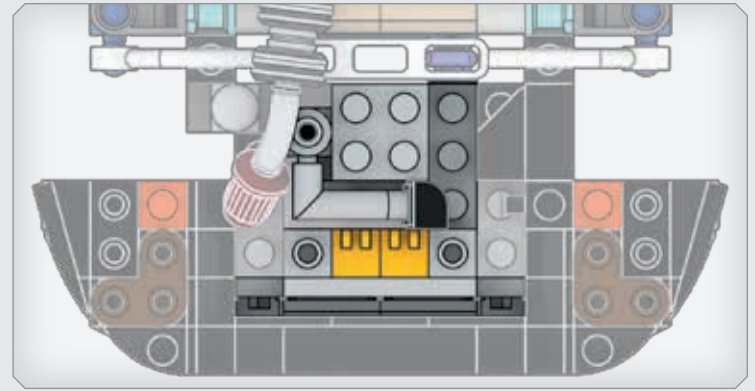

242

1x 1x

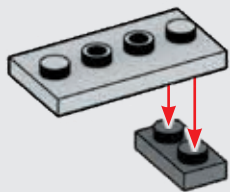

243

1x 1x 1x

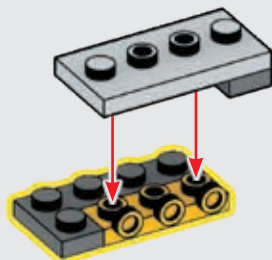

1

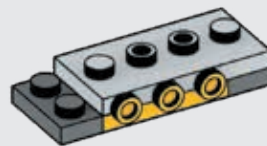

2

244

2x 1x

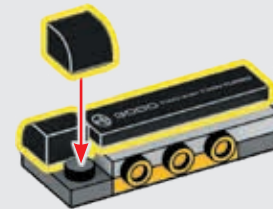

245

1x 1x 1x

1x 1x

1 2 3



1

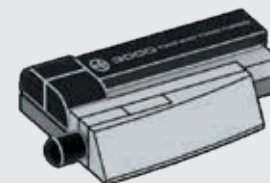

2

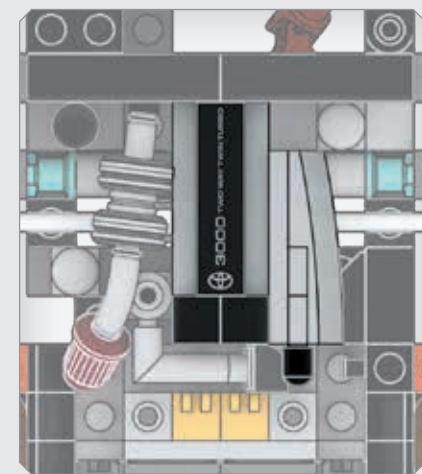
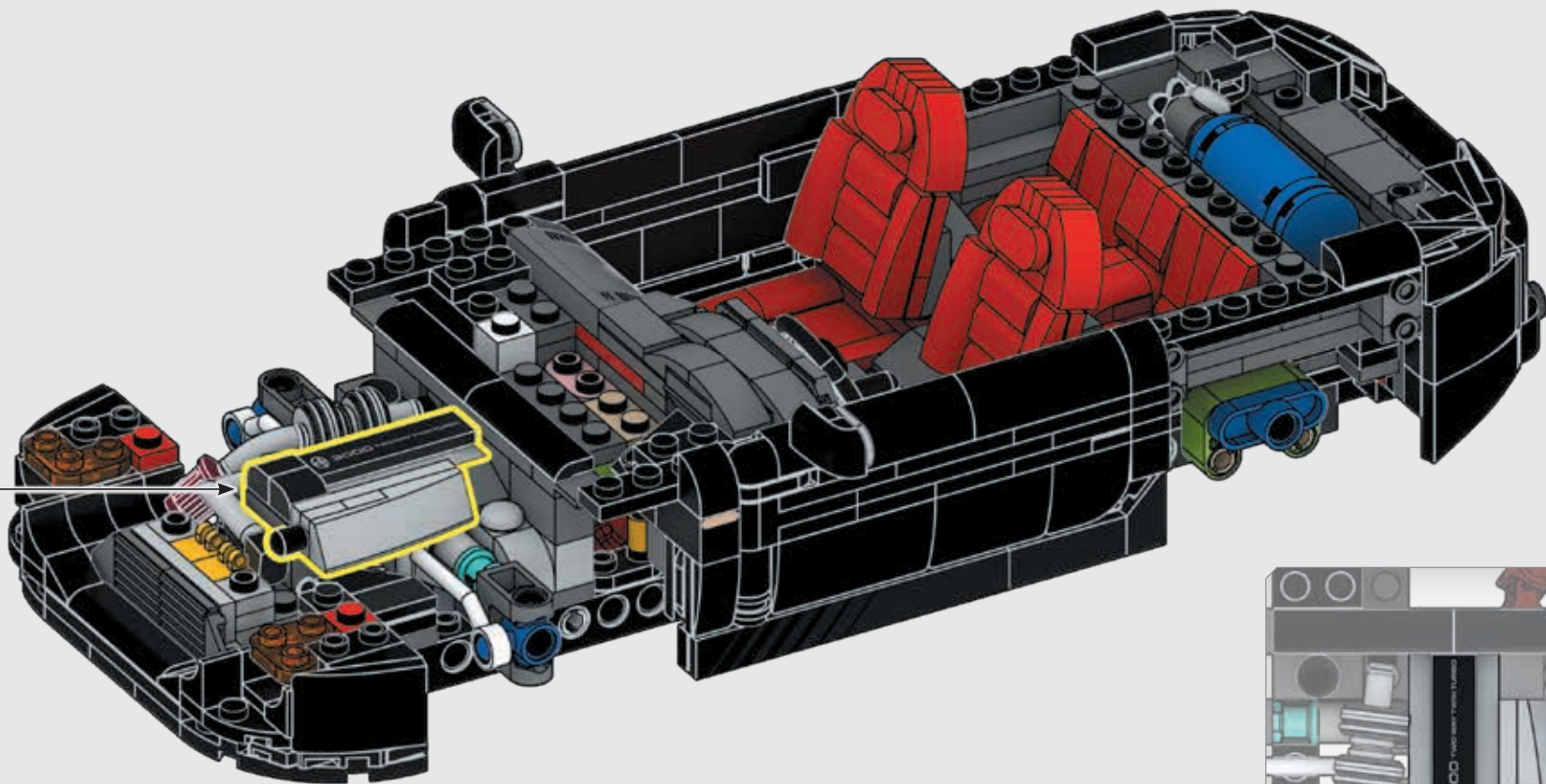

247



1x



1x

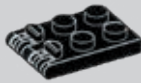

1x

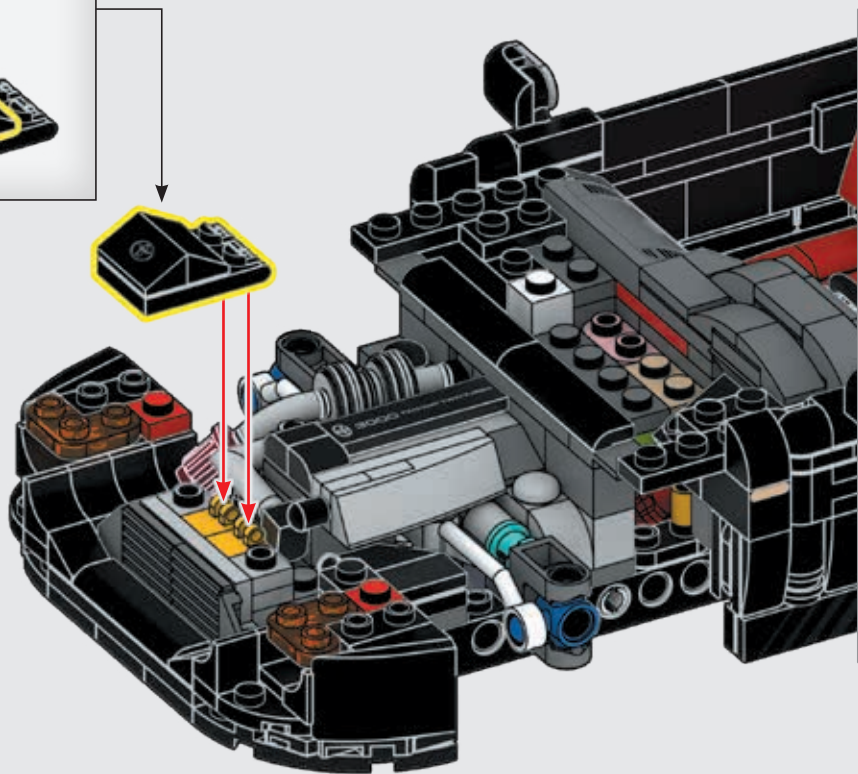
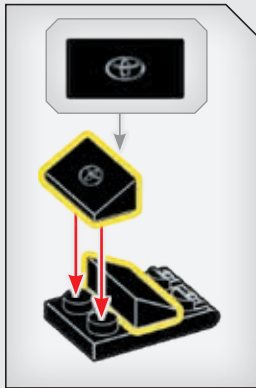

1

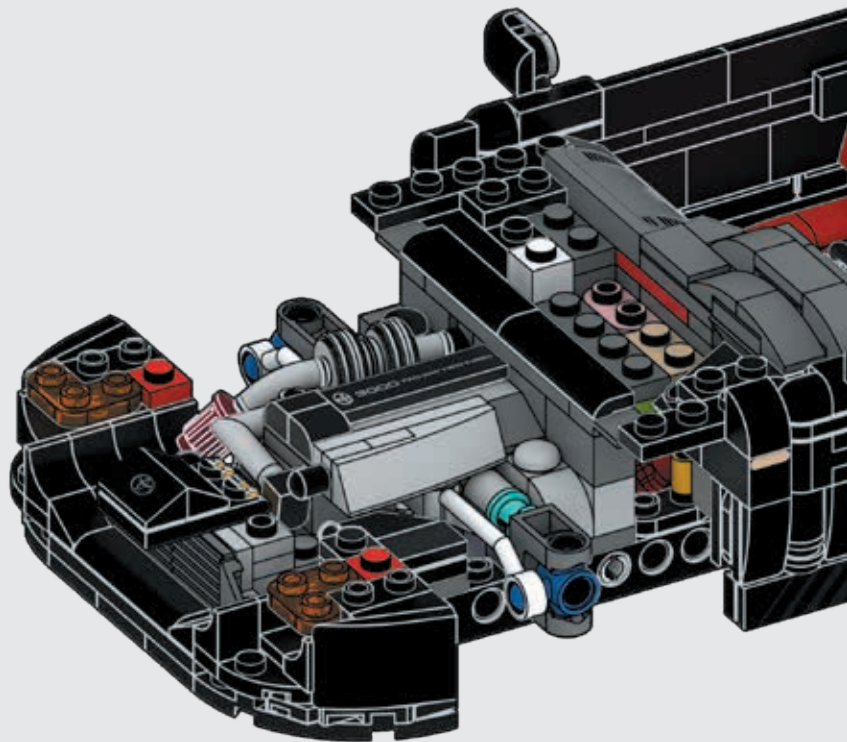

2

248



2x



2x



2x

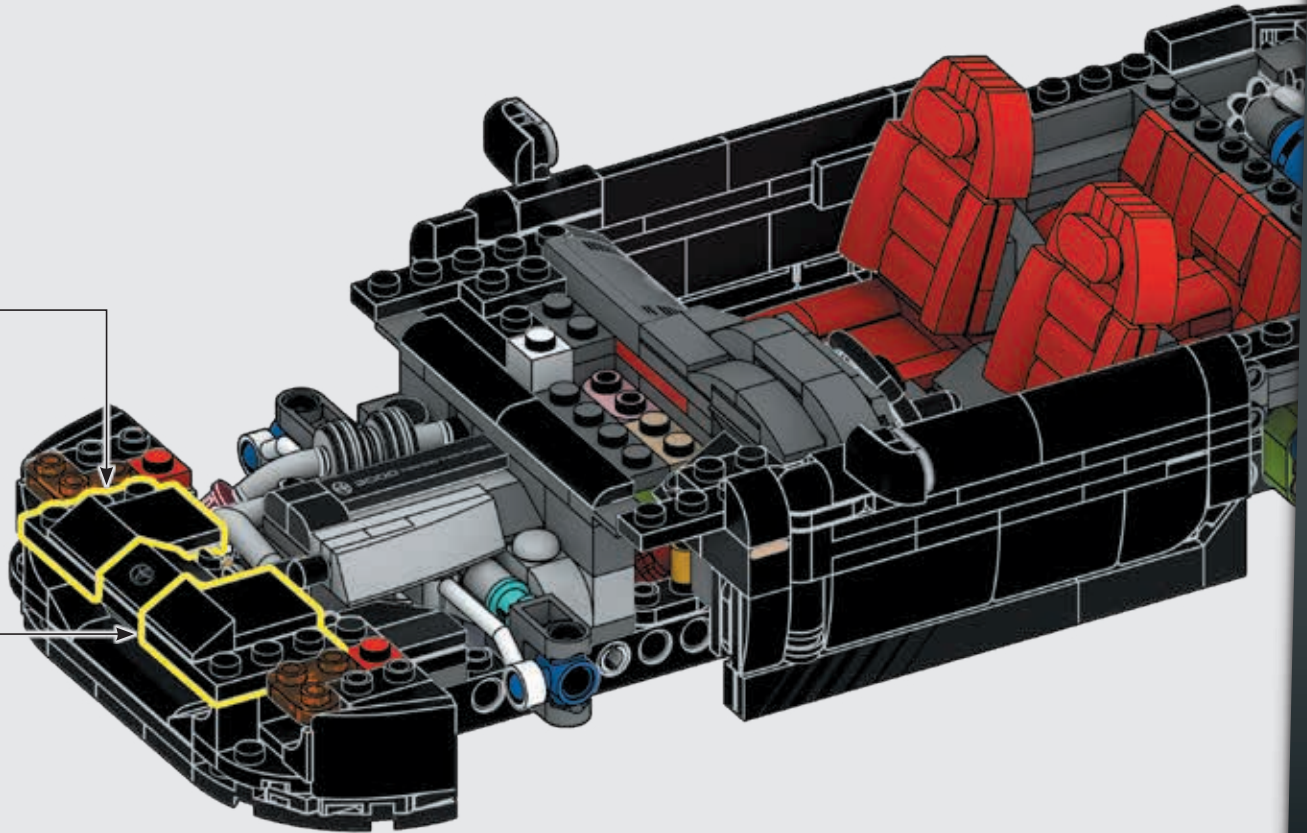
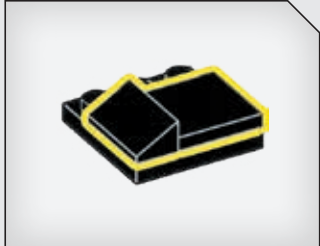

249



1x

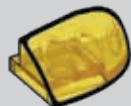

1x



2x

For maximum authenticity, our design team created custom headlight pieces for the Toyota Supra MKIV.

Pour un maximum d'authenticité, notre équipe de designers a créé des phares personnalisés pour la Toyota Supra MKIV.

Para ofrecer la máxima autenticidad, nuestro equipo de diseño ha creado piezas personalizadas para los faros del Toyota Supra MKIV.

Um ein Höchstmaß an Authentizität zu erreichen, hat unser Designteam individuell gestaltete Scheinwerferteile für den Toyota Supra MKIV entwickelt.

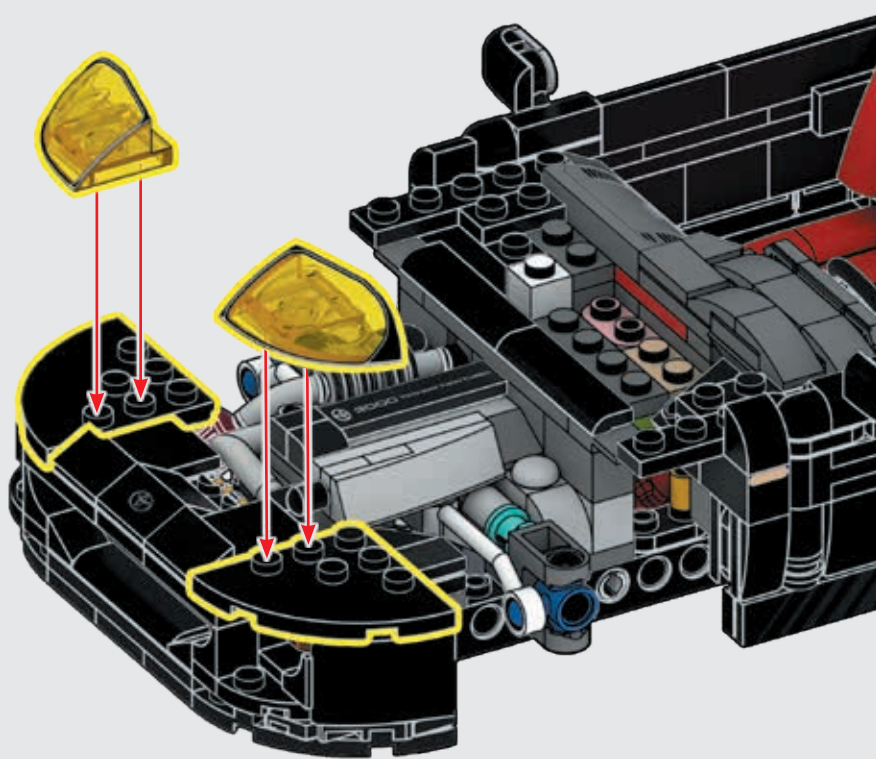
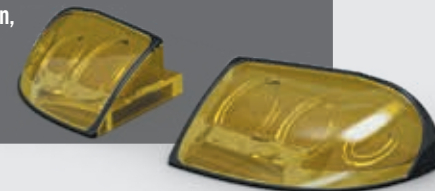

1

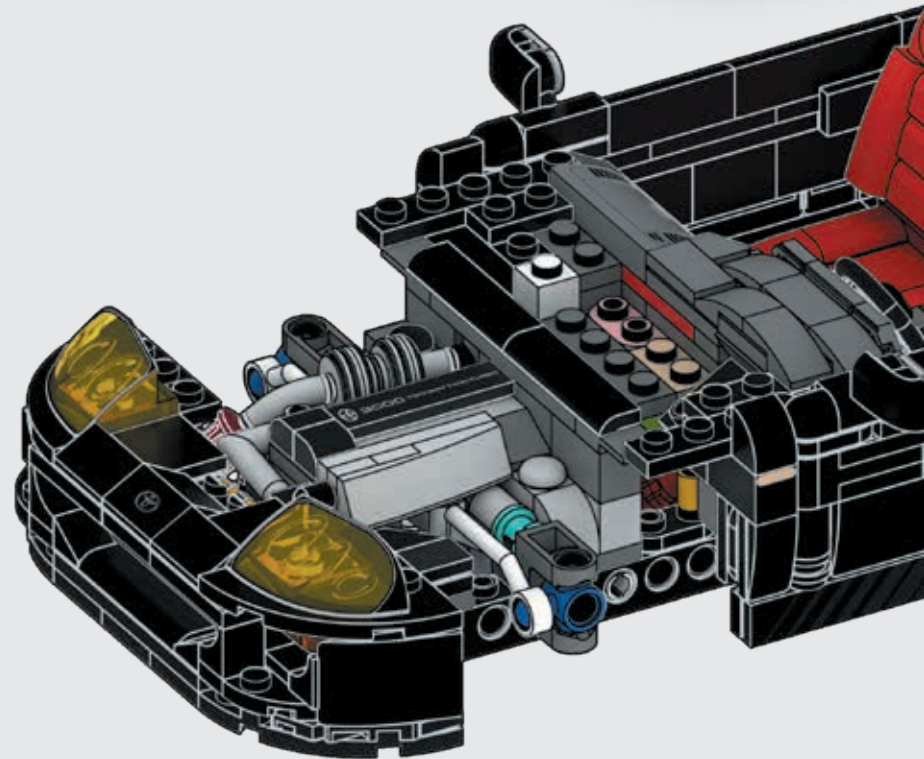

2

250

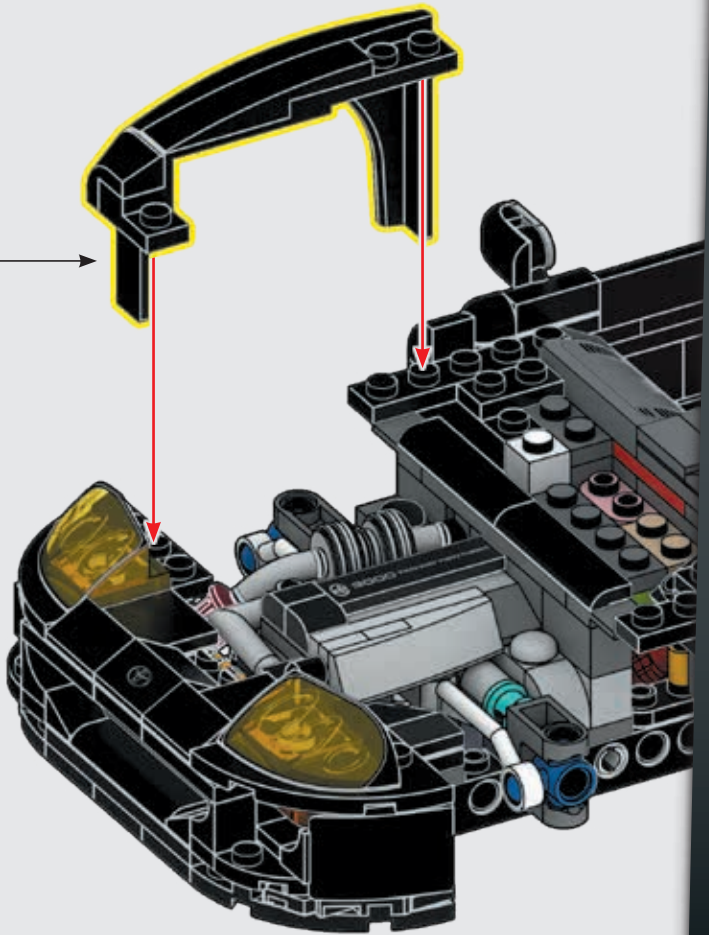
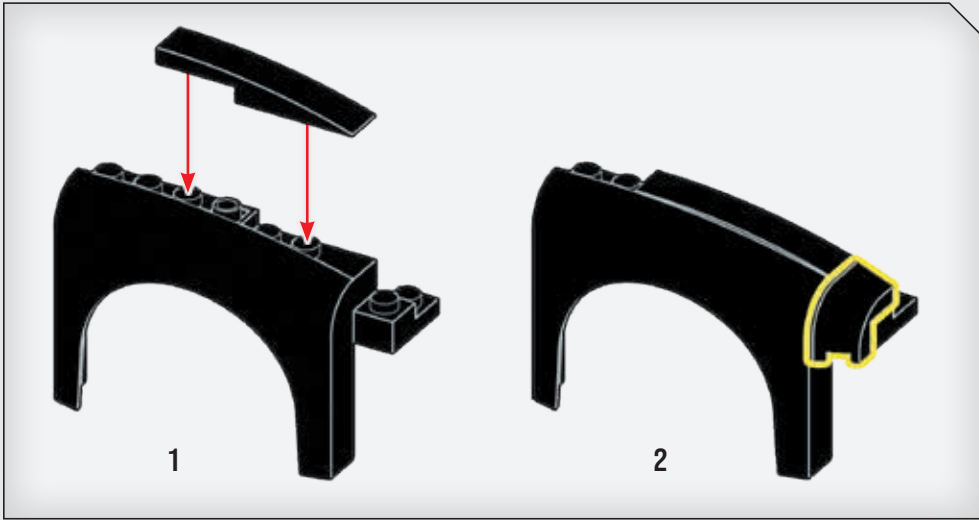
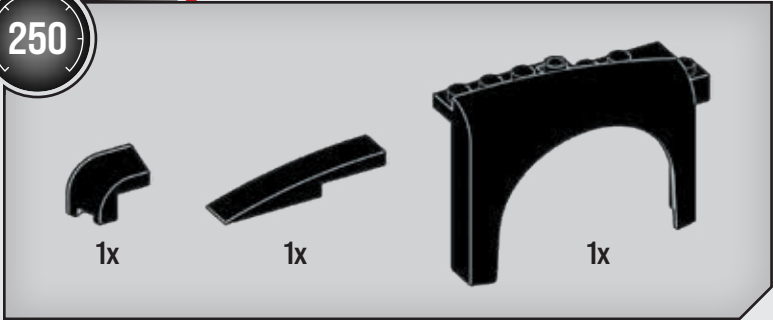

251



1x



1x

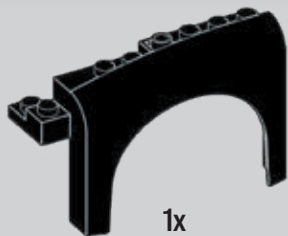

1x

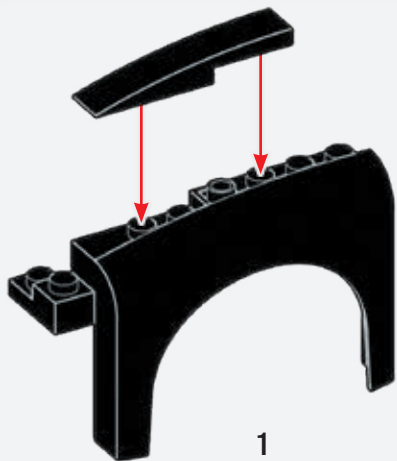

1

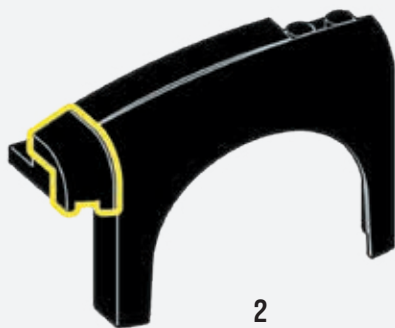

2

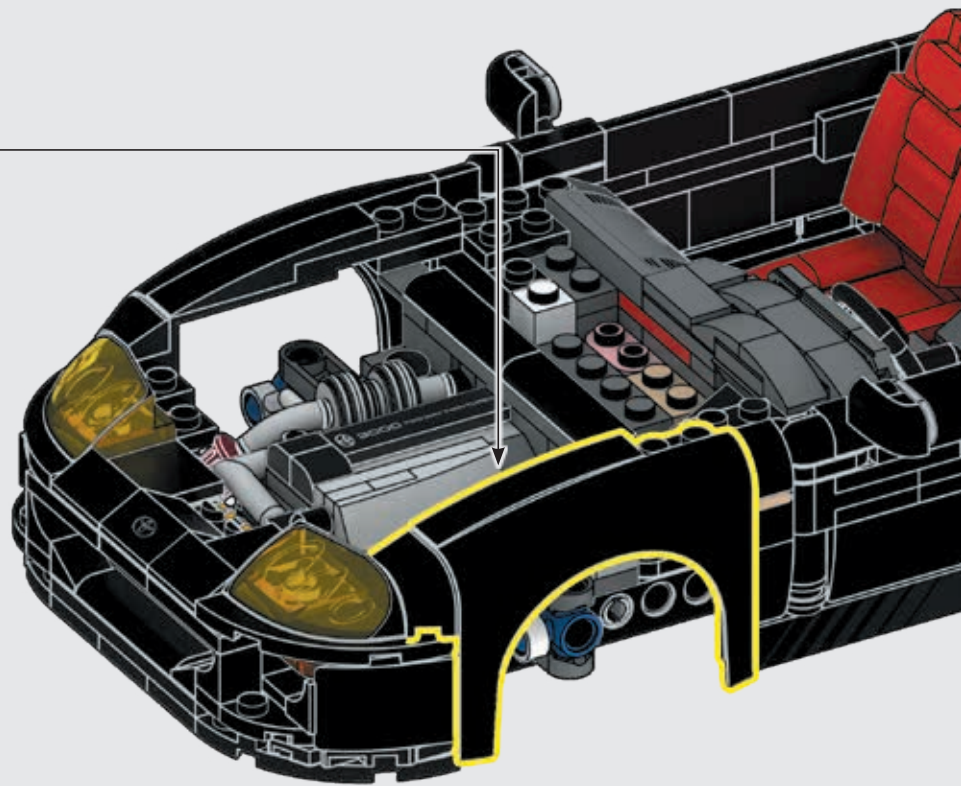

252



2x

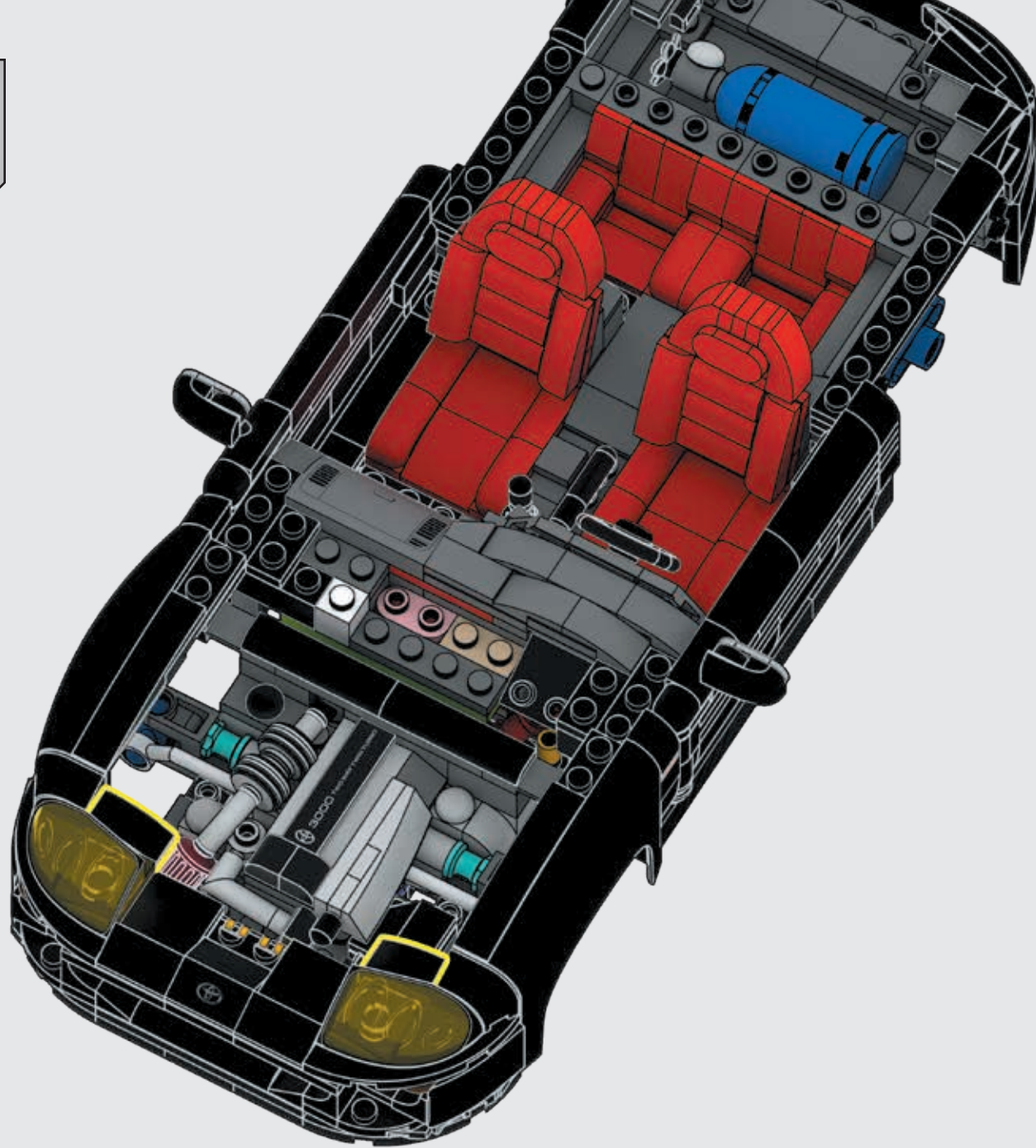

253



1x



1x



1x



1



2

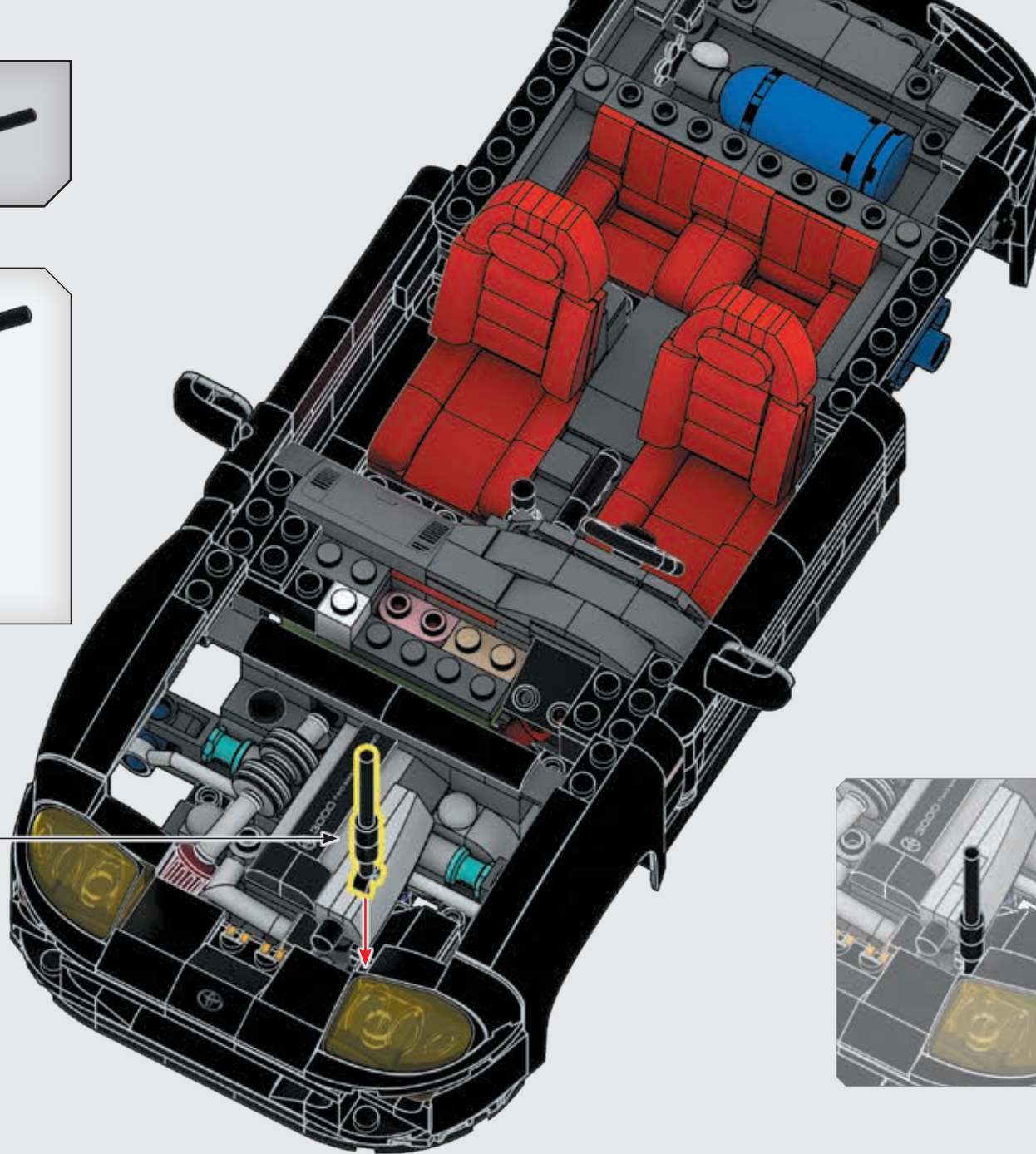

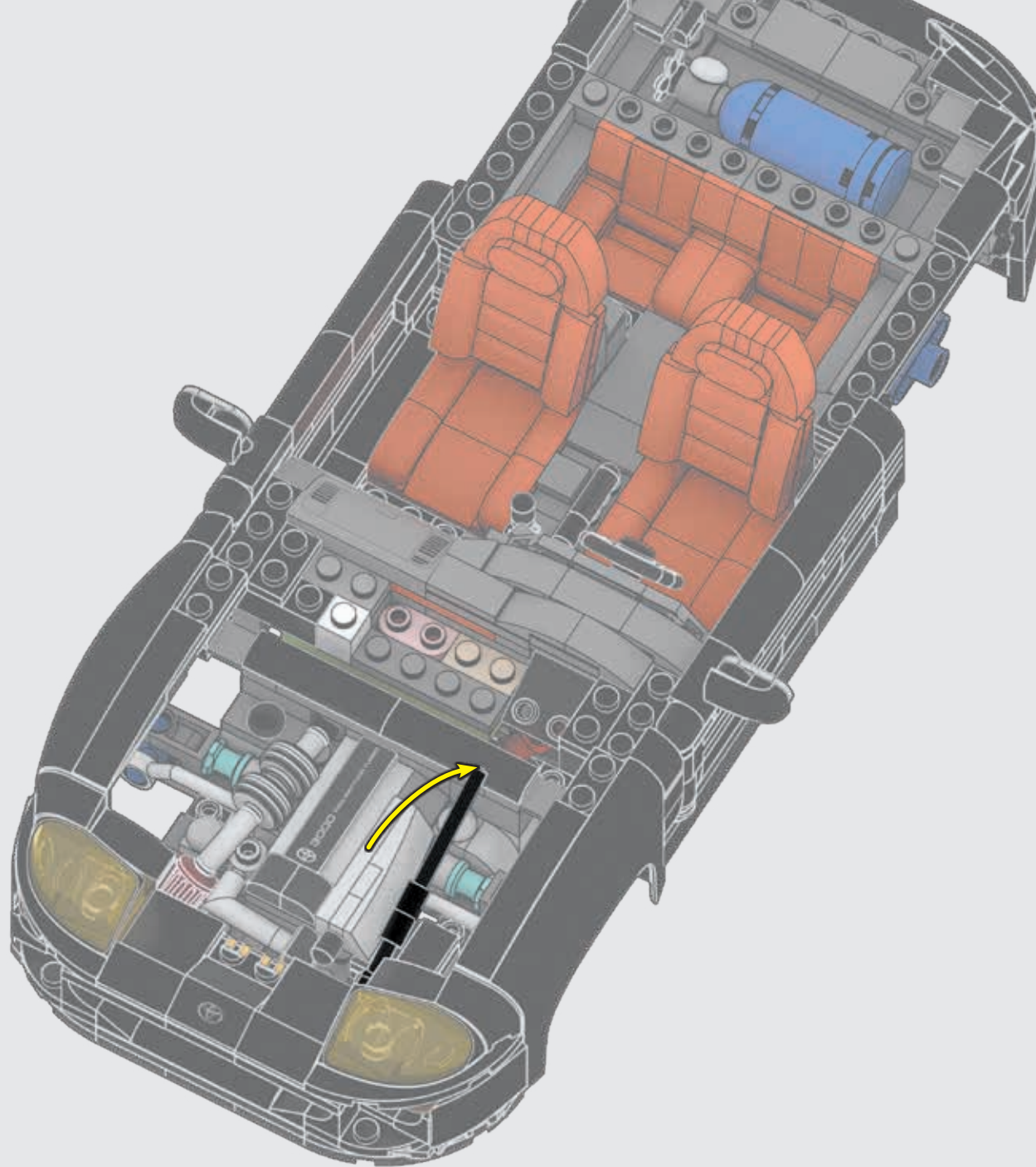

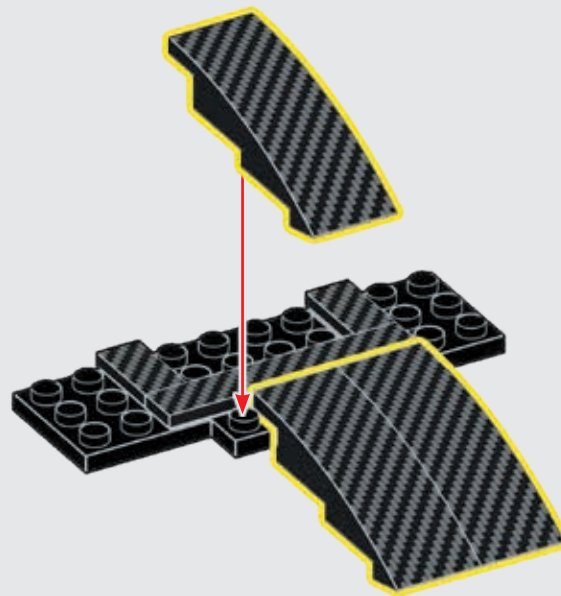
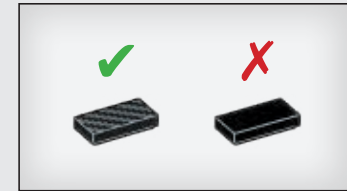

258

2x

2x8

1x

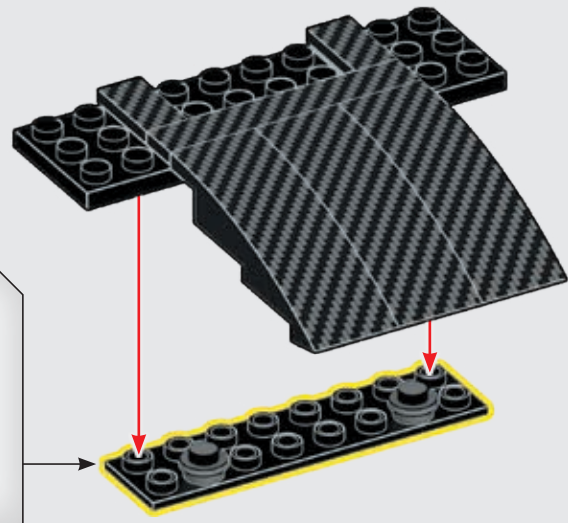
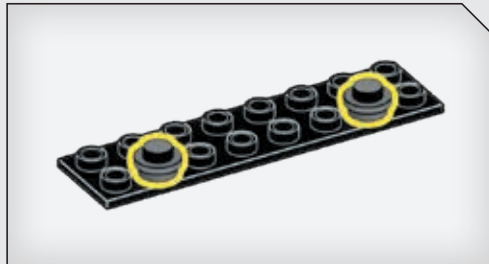
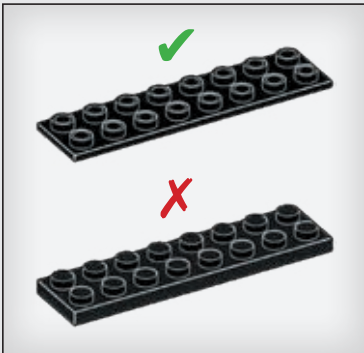

259

2x

2x8

1x

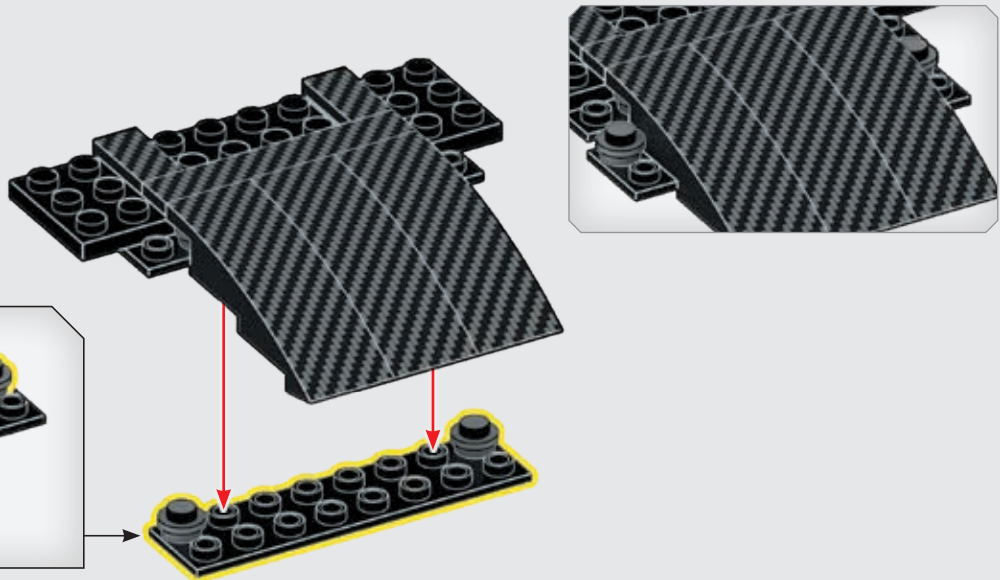
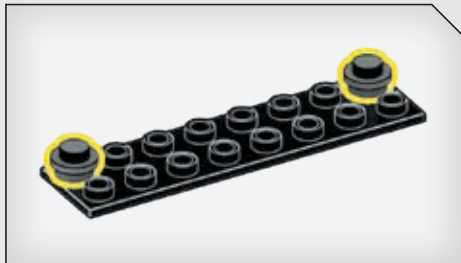
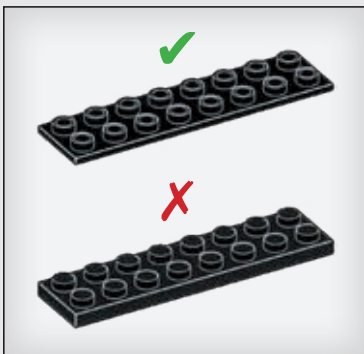

260

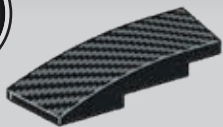

1x

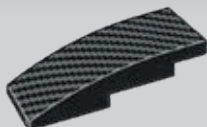

1x

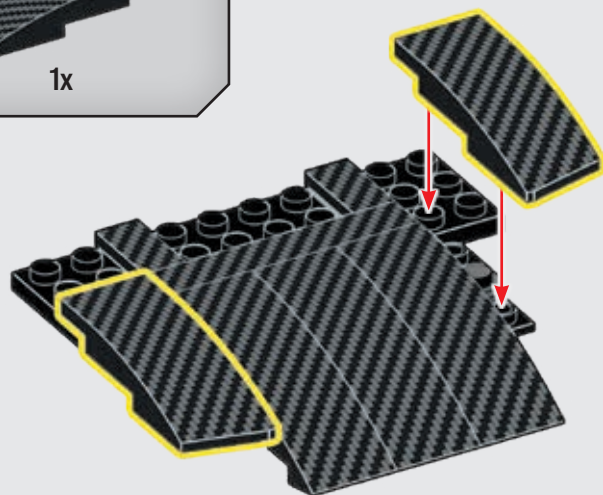

1

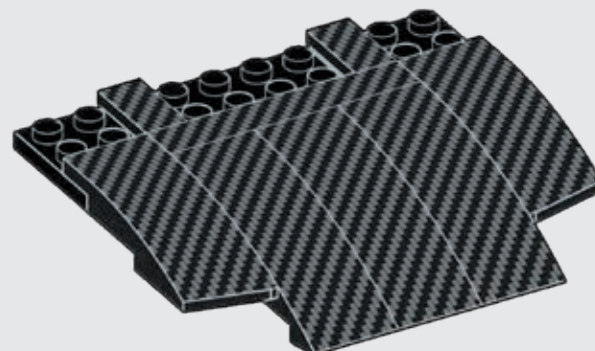

2

261



2x



1x

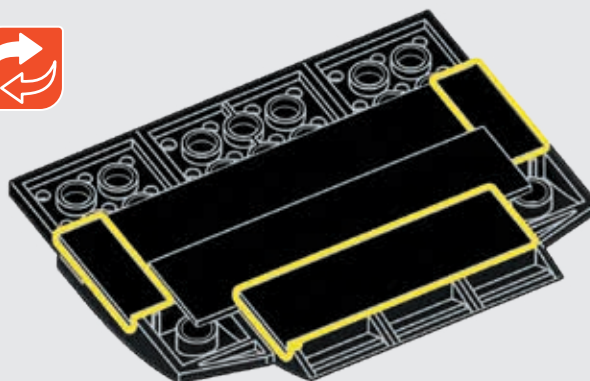

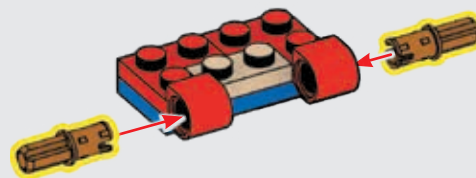
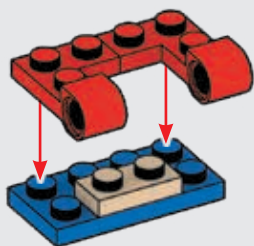
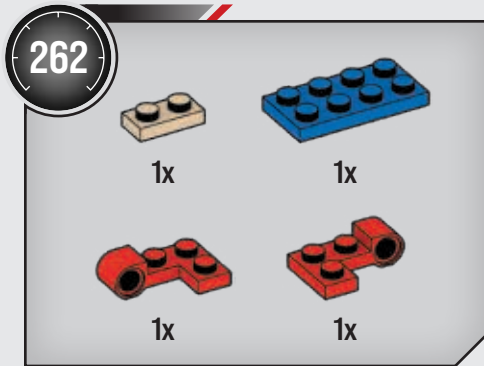

1

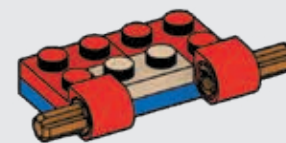

2

264



2x



2x

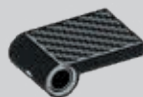

2x

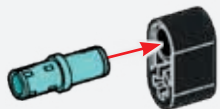

1

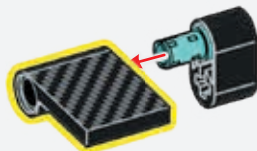

2

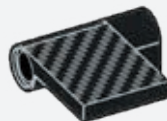

3

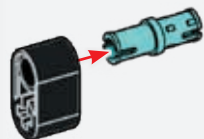

1

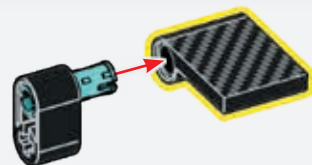

2

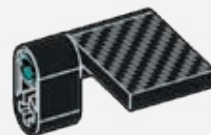

3

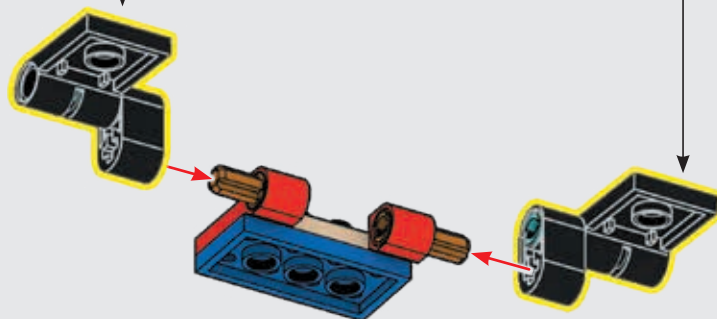

265

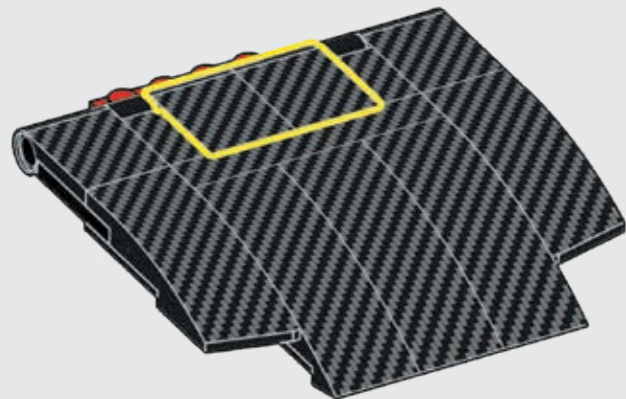
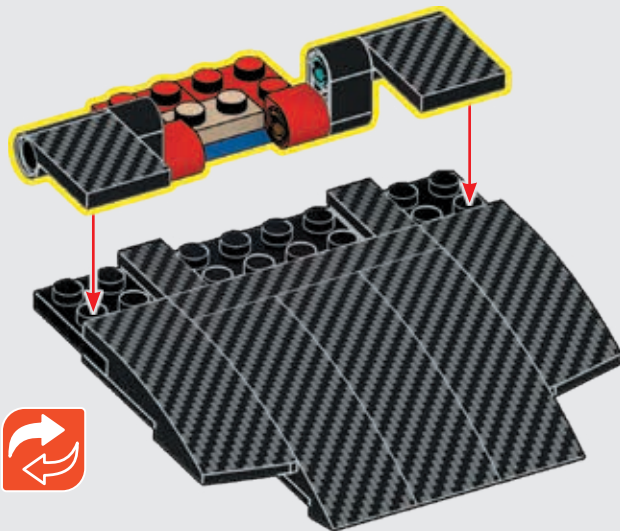

This is the first ever building set to contain carbon fiber-style parts, created by our design team to elevate the build. The Toyota Supra includes 9 custom textured parts, including the hood, skirt, and flat spoiler.

C'est le tout premier ensemble de construction à contenir des pièces de style fibre de carbone, créé par notre équipe de design pour élever l'ensemble. La Toyota Supra comprend 9 pièces texturées personnalisées, dont le capot, le bas de caisse et le spoiler plat.

Este es el primer set de construcción que incluye piezas con estilo de fibra de carbono, creado por nuestro equipo de diseño para elevar la experiencia de construcción. El Toyota Supra incluye 9 piezas texturizadas personalizadas, entre las que se incluyen el capó, el faldón y el alerón plano.

Dies ist das erste Bauset überhaupt mit Bauteilen im Kohlefaser-Stil, entwickelt von unserem Designteam, um den Bau auf ein neues Niveau zu heben. Der Toyota Supra umfasst 9 individuell gestaltete strukturierte Bauteile, darunter die Motorhaube, die Schürze und der flache Spoiler.

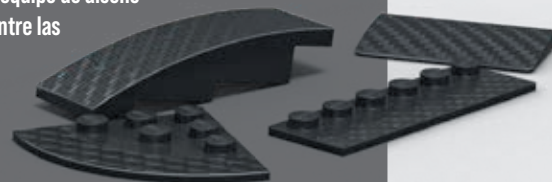

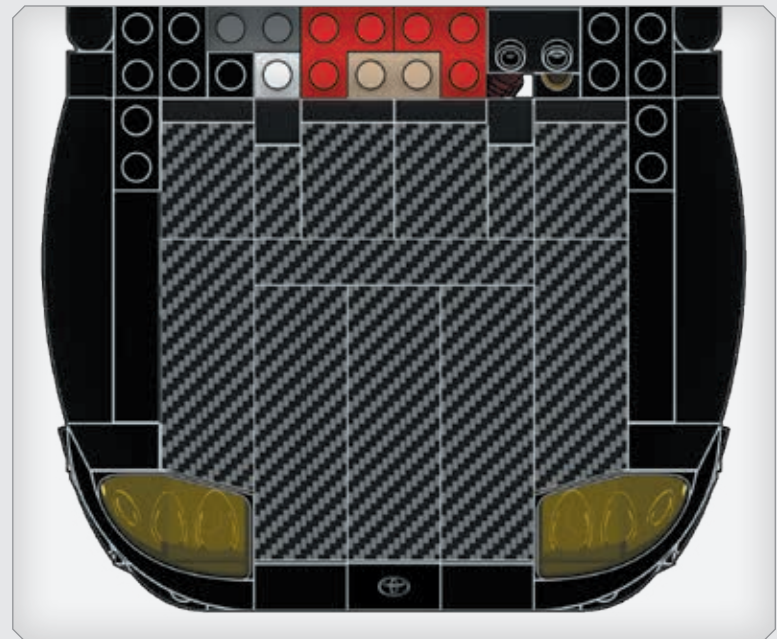
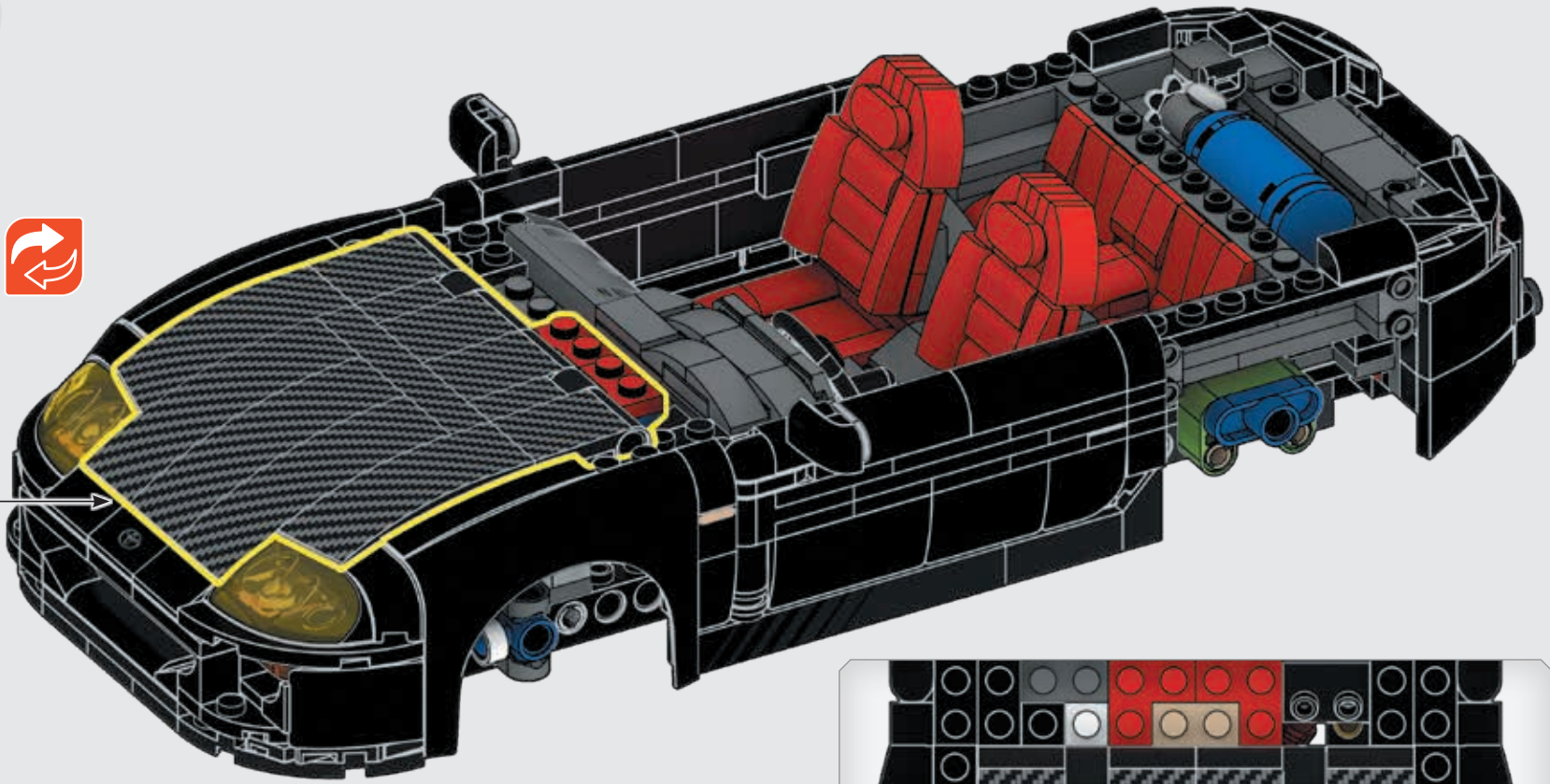

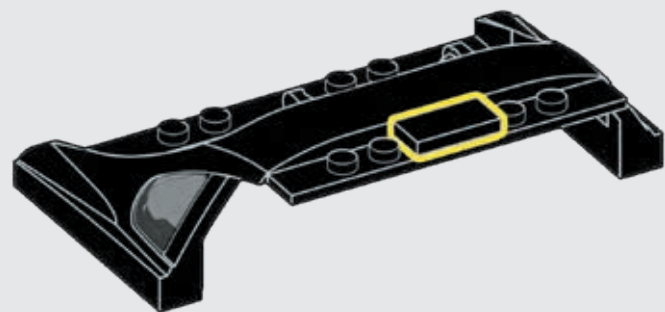
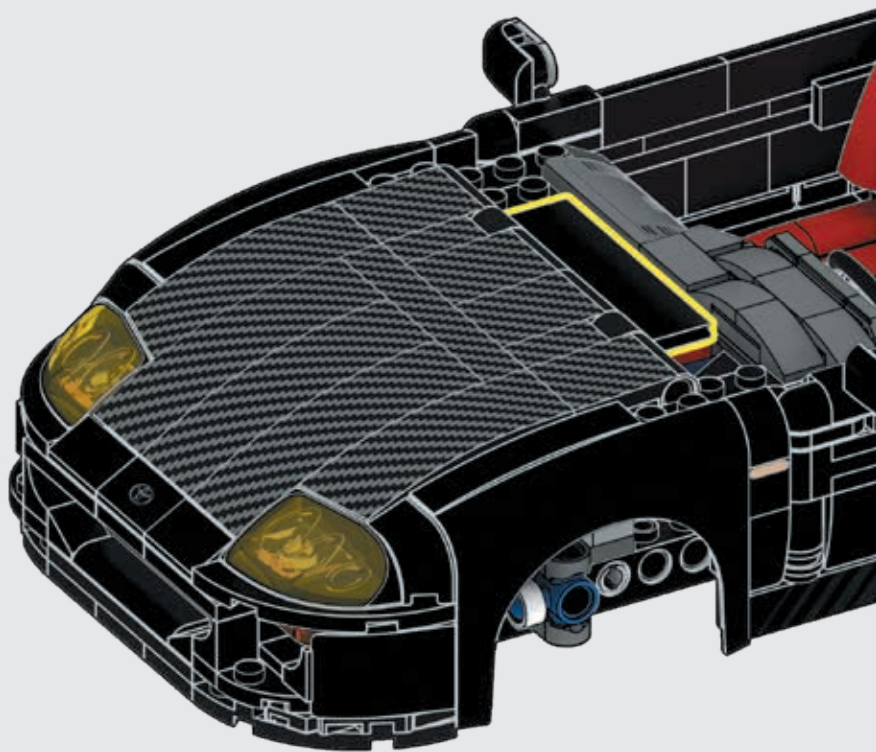
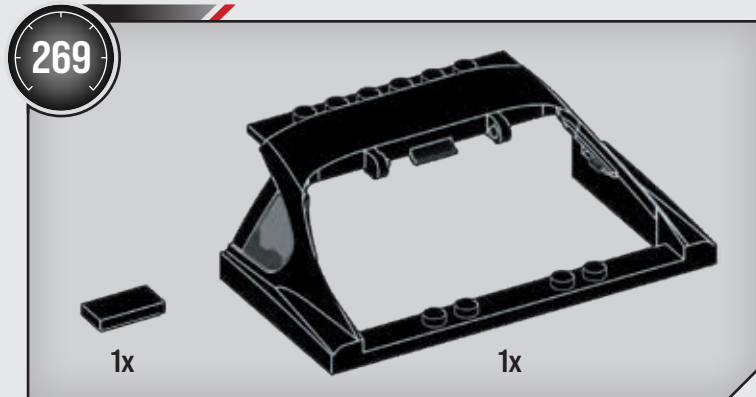
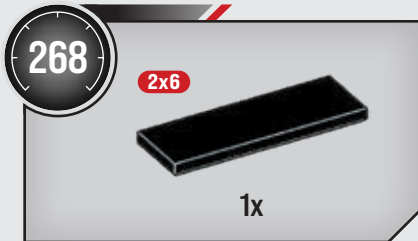

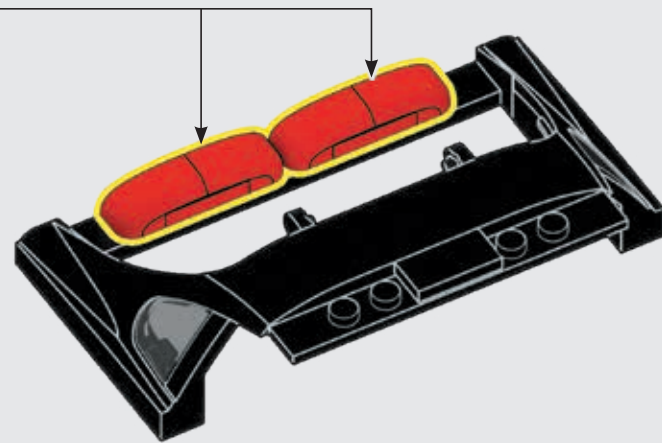
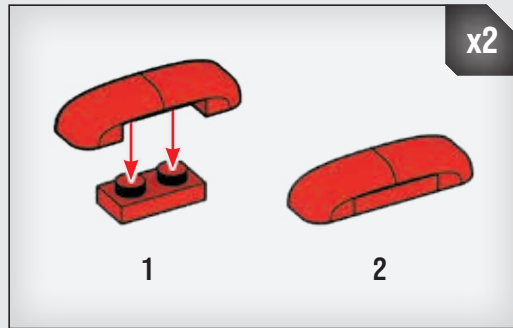
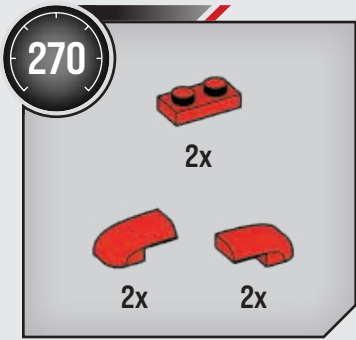

271

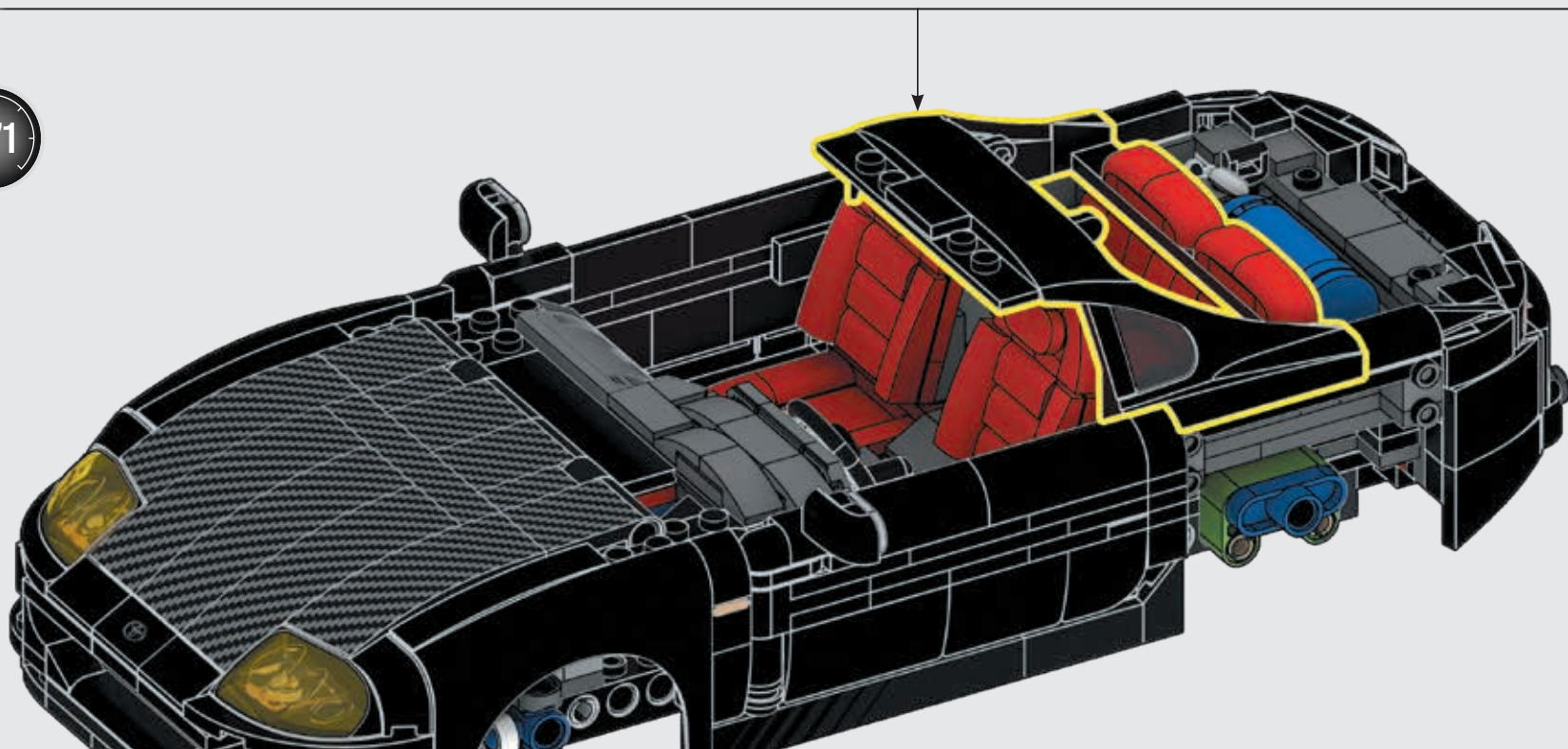

272



1x



1x



1x

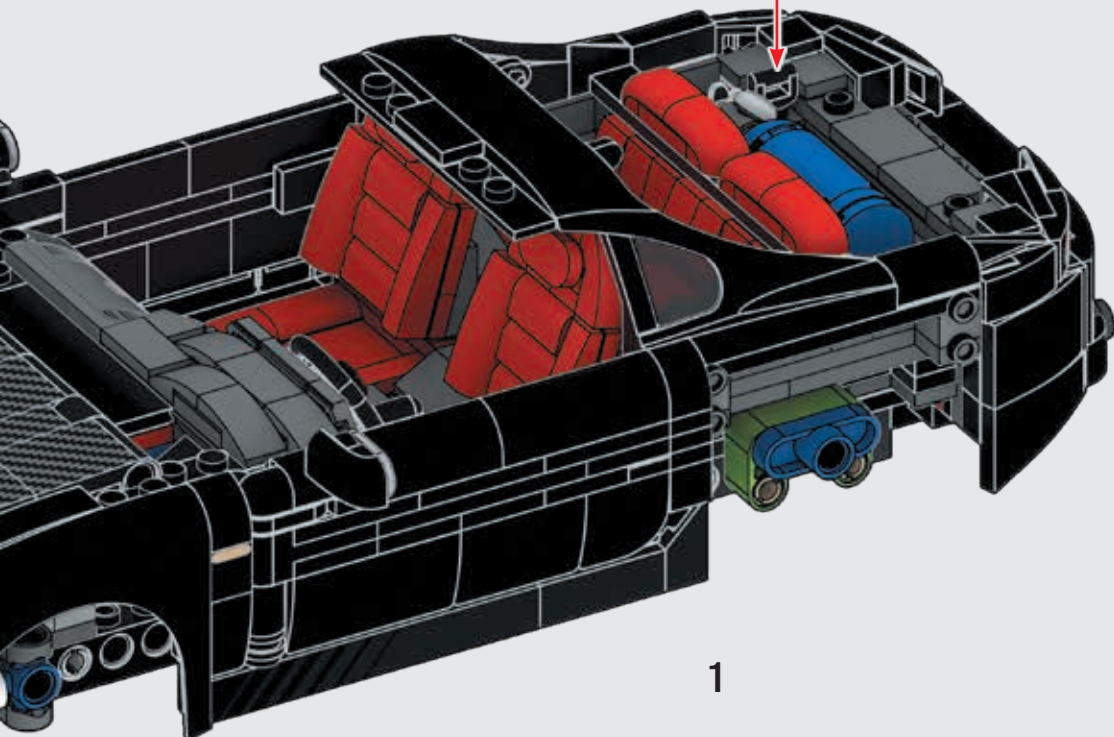
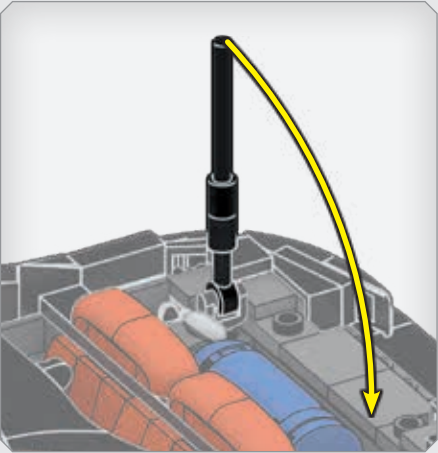
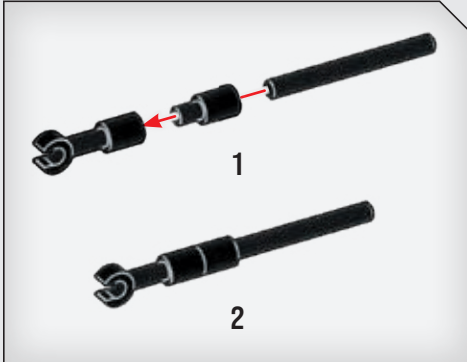

1

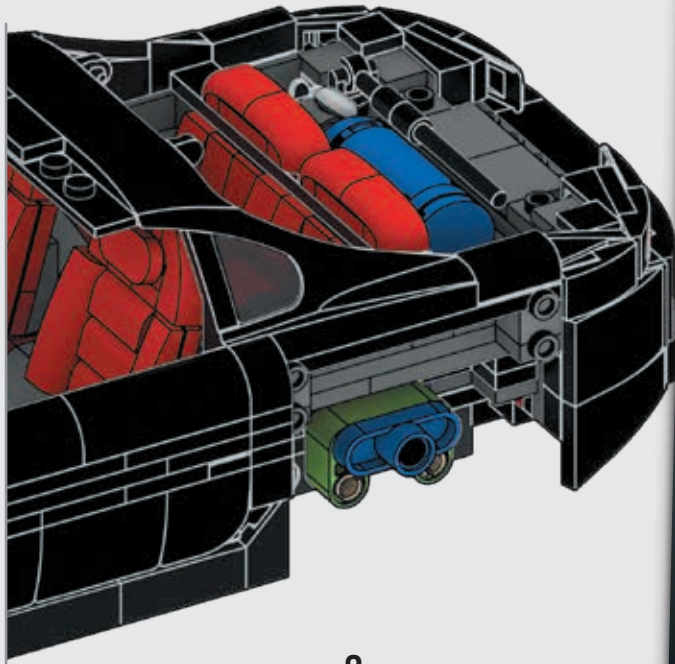

2

273

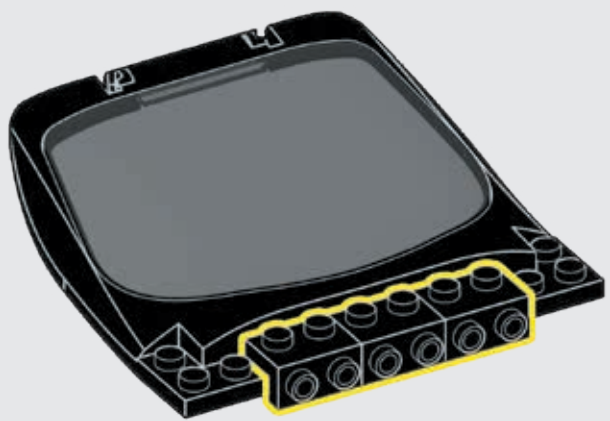
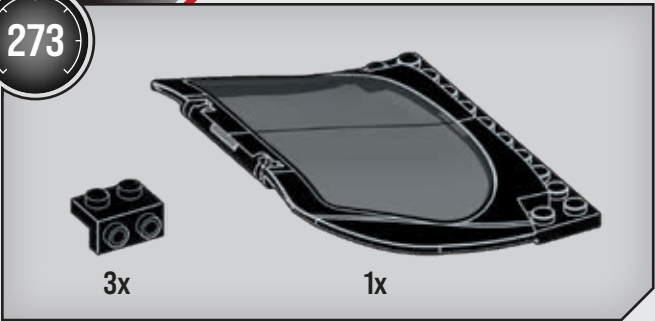

274

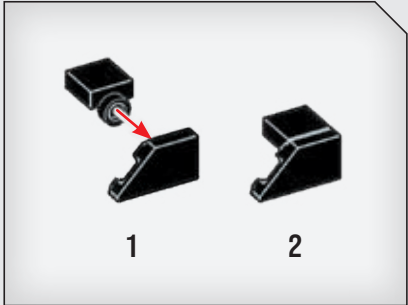

2

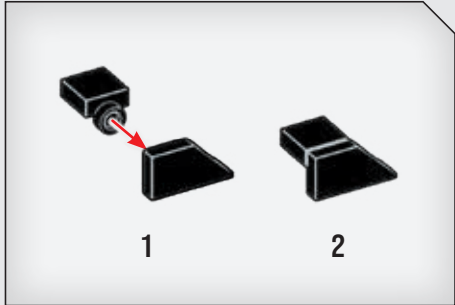

2

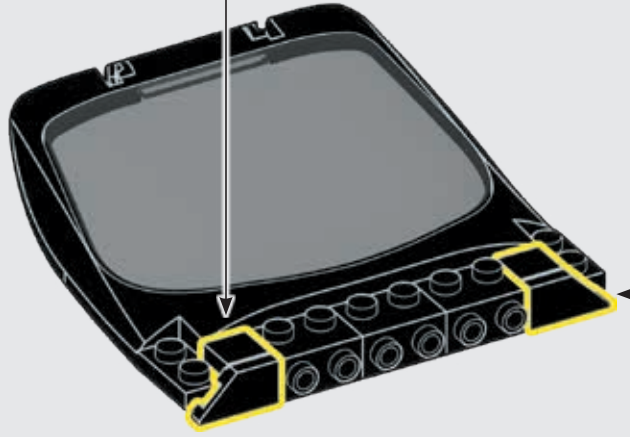

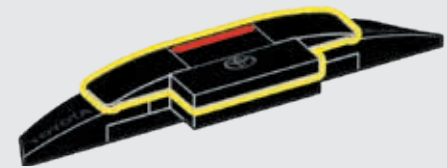
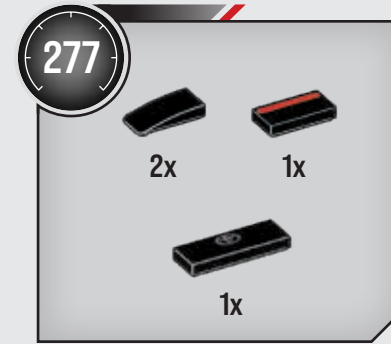
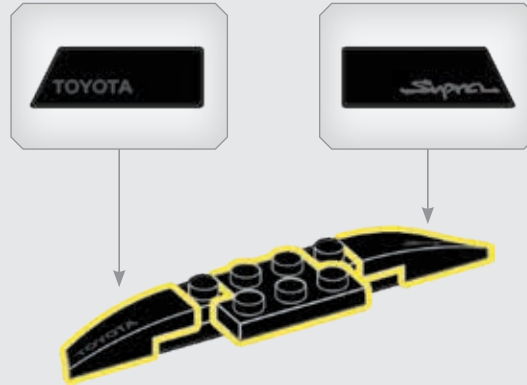
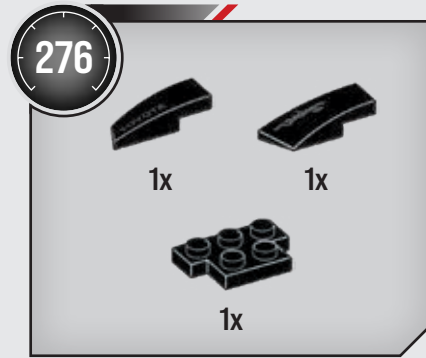
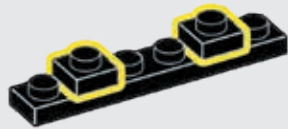
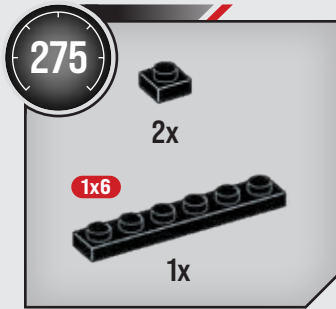

278

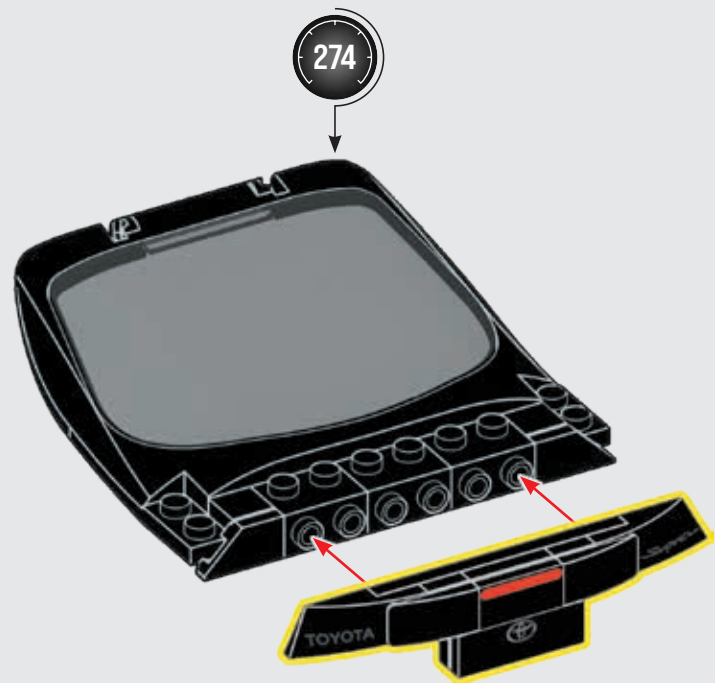

279

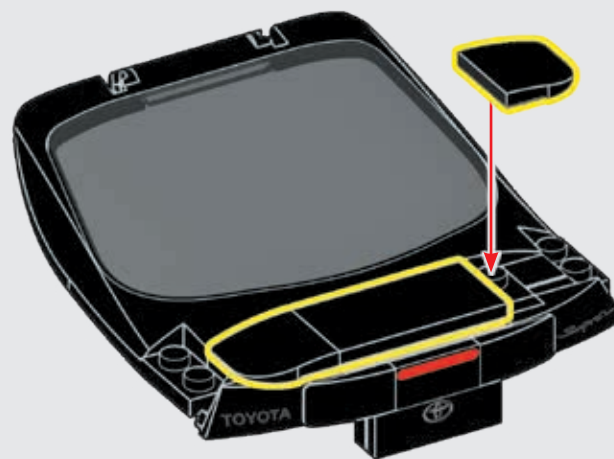
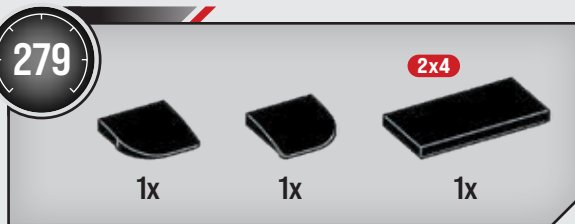

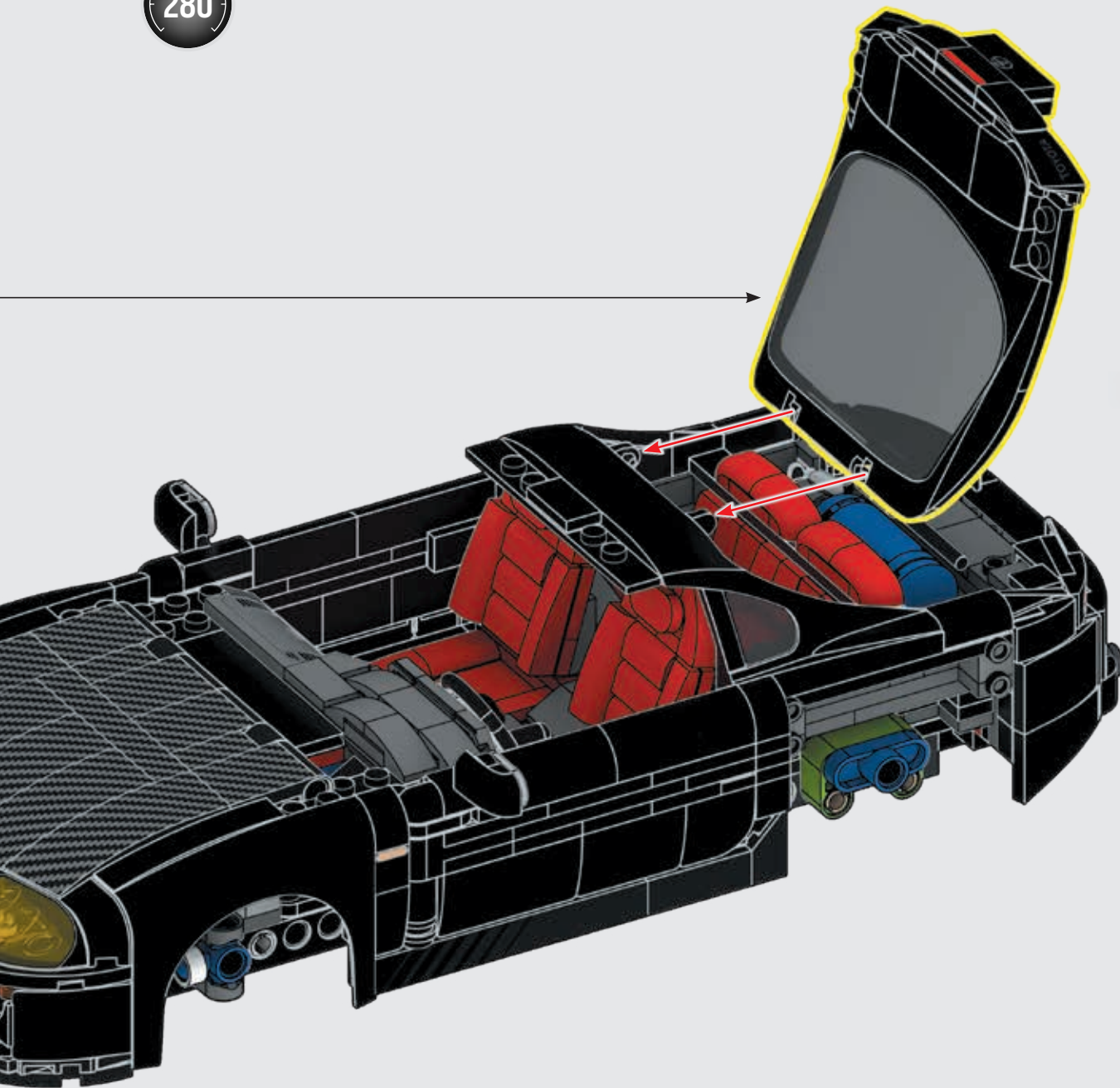

The back windshield was designed in 3 custom parts: the frame, the glass, and the hatch.

Le pare-brise arrière a été conçu en 3 parties personnalisées: le cadre, le verre et le hayon.

El parabrisas trasero está formado por tres piezas personalizadas: el marco, el cristal y el maletero.

Die Heckscheibe besteht aus drei individuell gestalteten Teilen: Rahmen, Glas und Klappe.



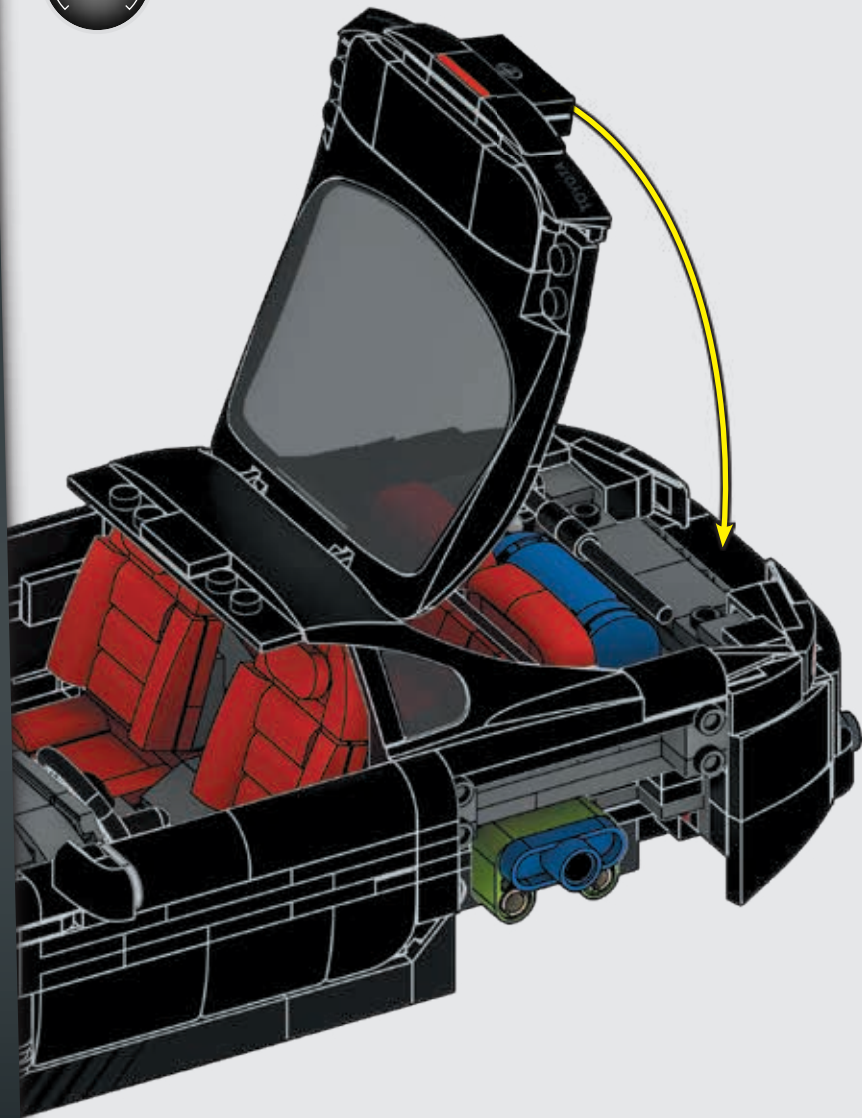

1

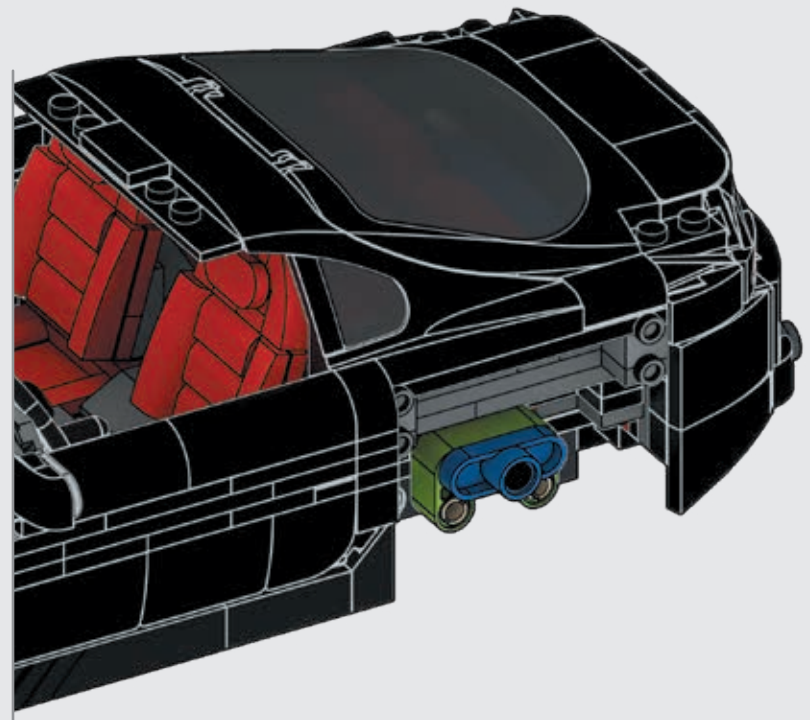

2

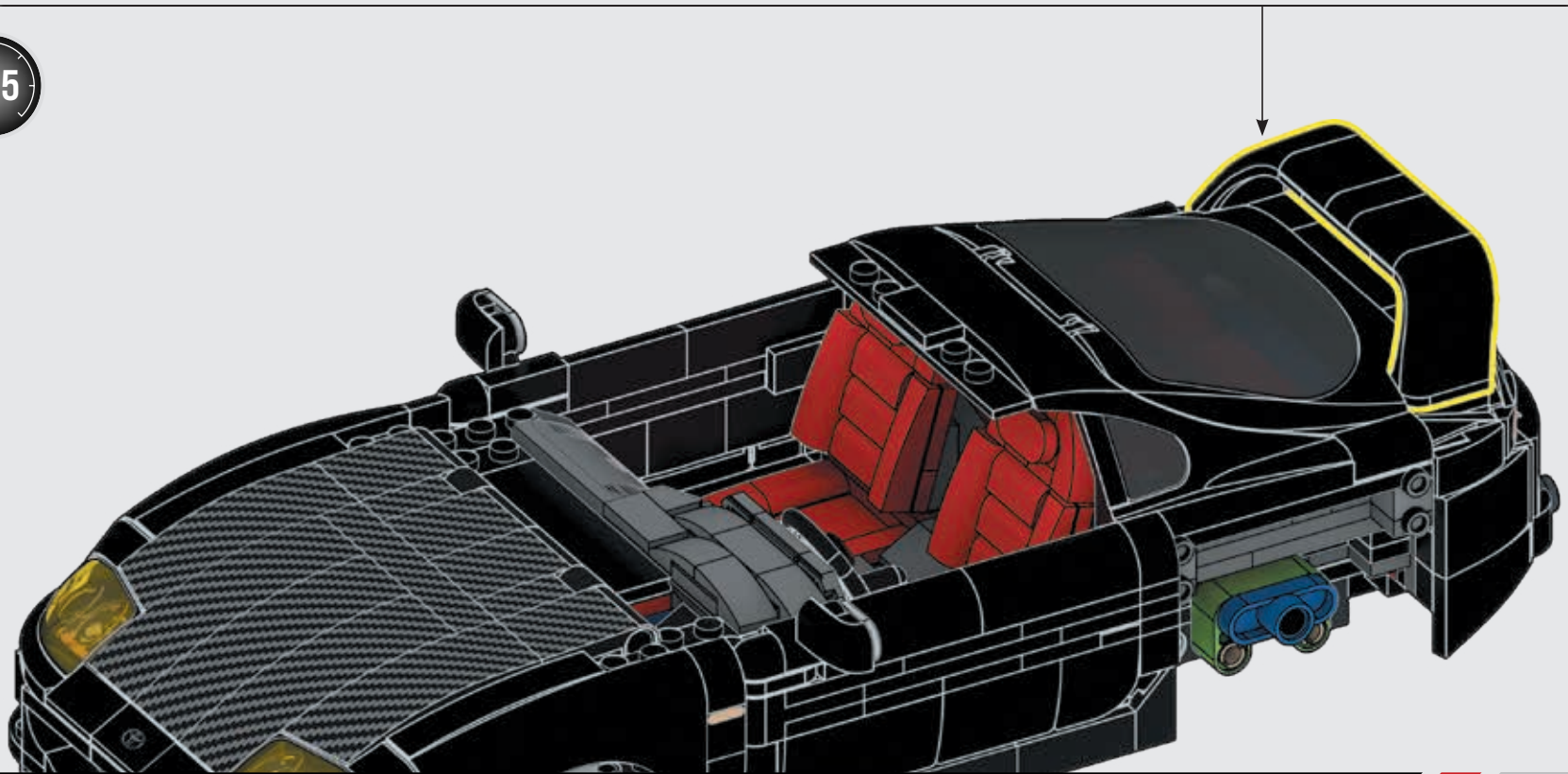
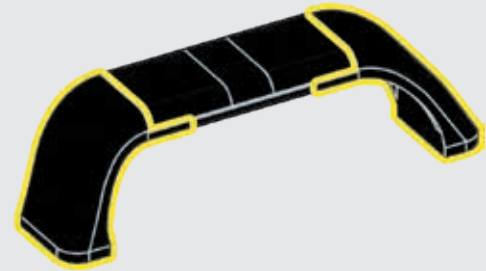
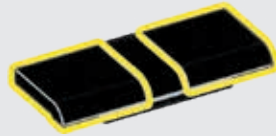
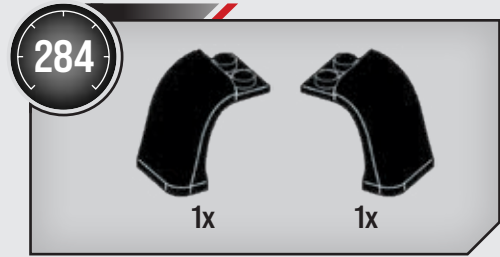
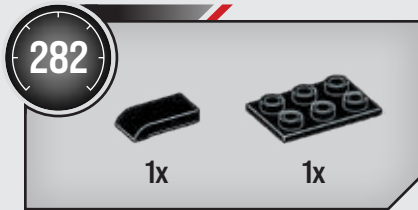

286

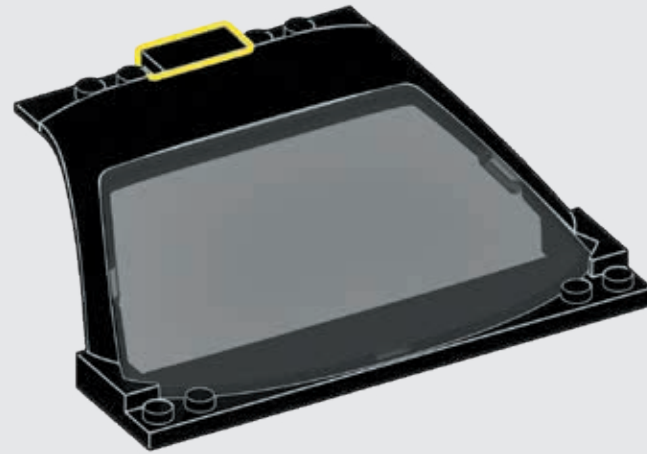
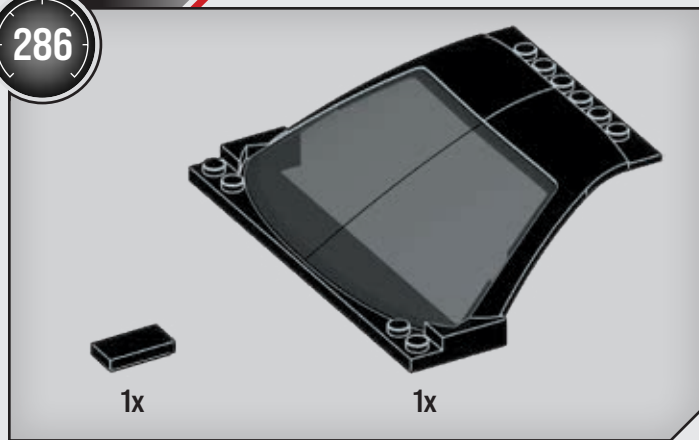

287

This tinted windshield piece was designed specifically for the Supra MKIV.

Ce pare-brise teinté a été spécialement conçu pour la Supra MKIV.

Este parabrisas tintado se ha diseñado específicamente para el Supra MKIV.

Dieses getönte Windschutzscheibenteil wurde speziell für den Supra MKIV entwickelt.

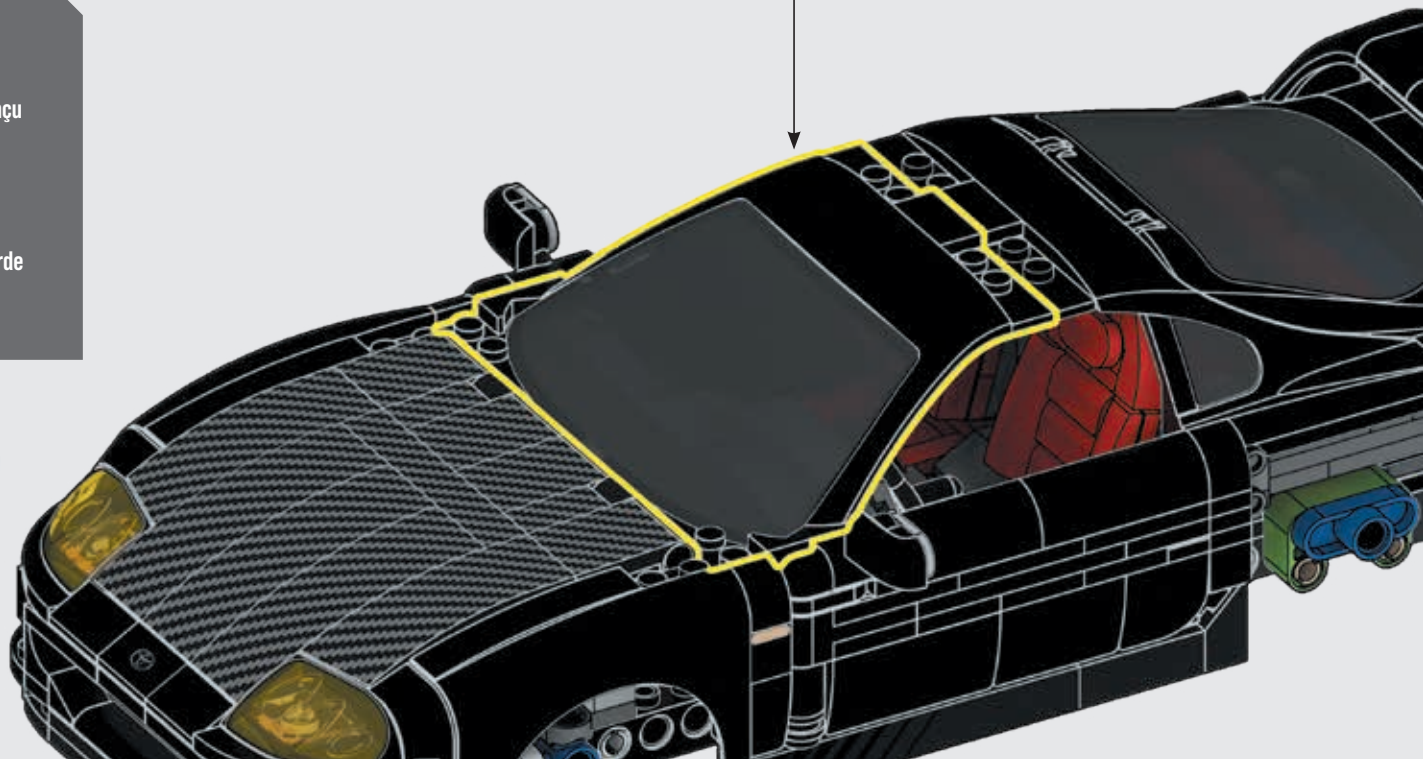

288



1x



1x

1x3



2x



2x

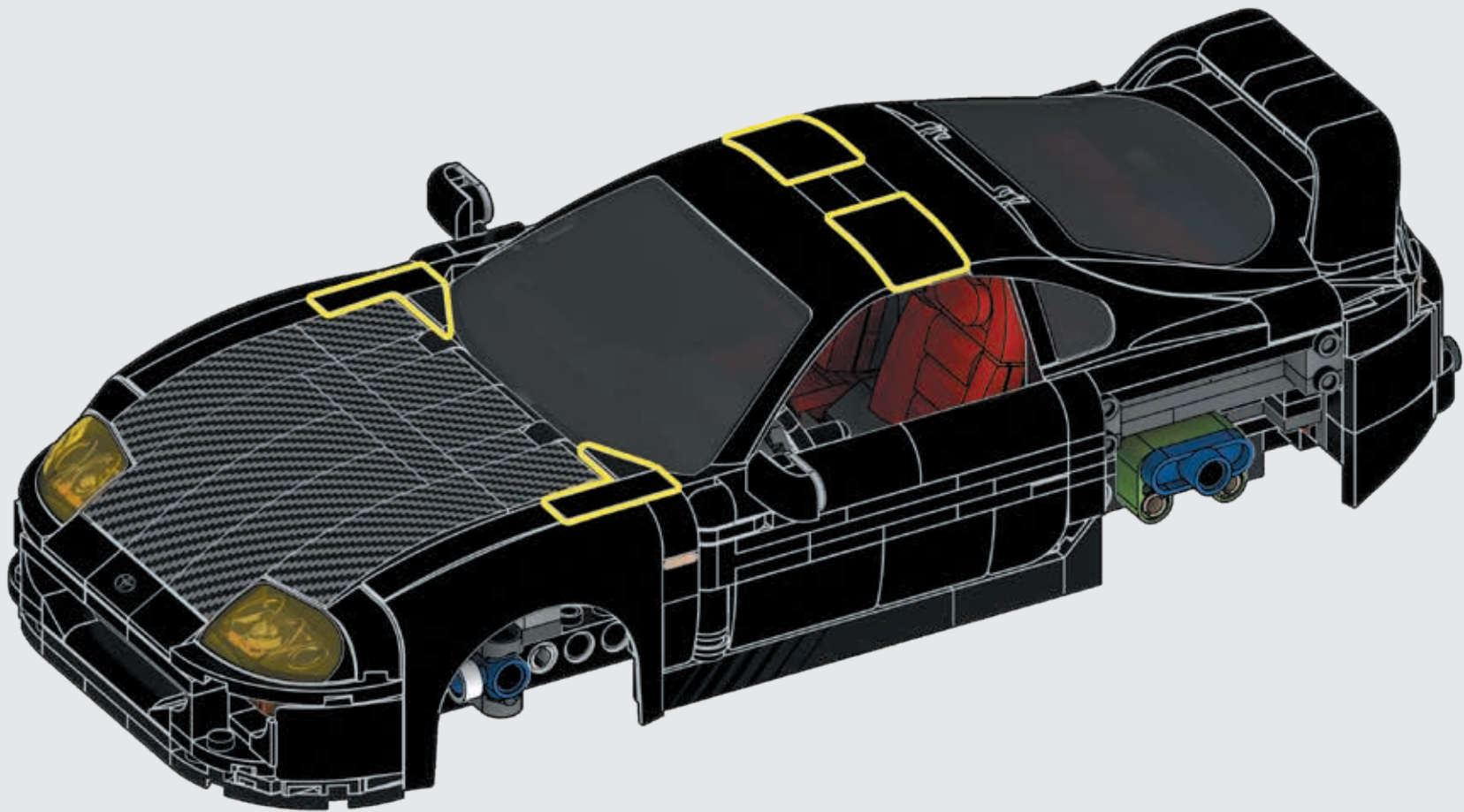

289

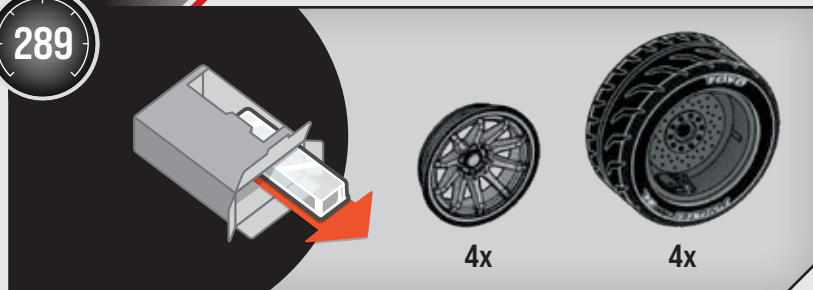

Includes officially licensed RAYS CE28 wheel covers and Toyo Tires Proxes R888R tires.

Comprend des enjoliveurs en métal RAYS CE28 et des pneus Toyo Tires Proxes R888R sous licence officielle.

Incluye tapacubos metálicos RAYS CE28 y neumáticos Proxes R888R de Toyo Tires con licencia oficial.

Mit offiziell lizenzierten CE28-Radkappen aus Metall von RAYS und Toyo Tires Proxes R888R-Reifen.

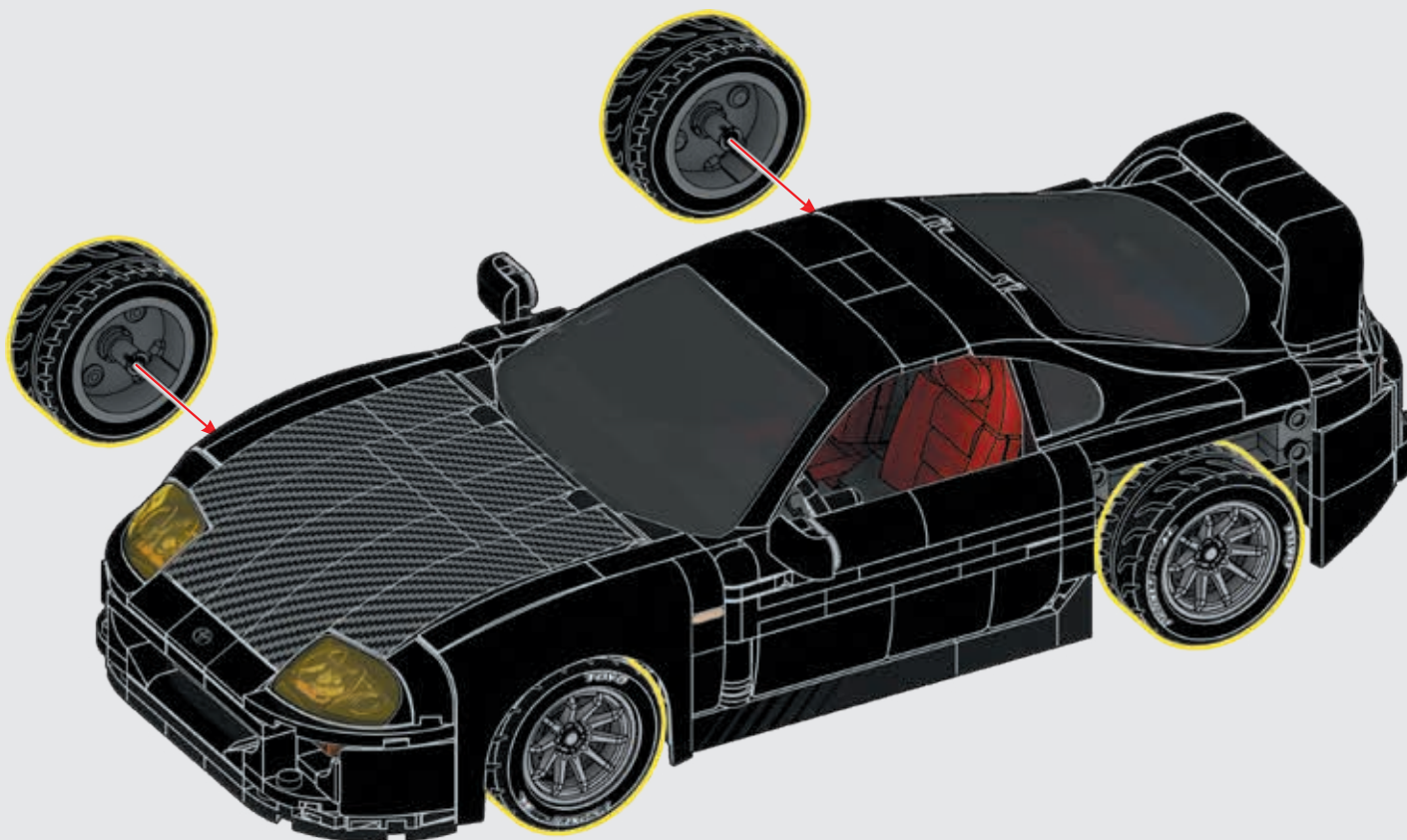

290

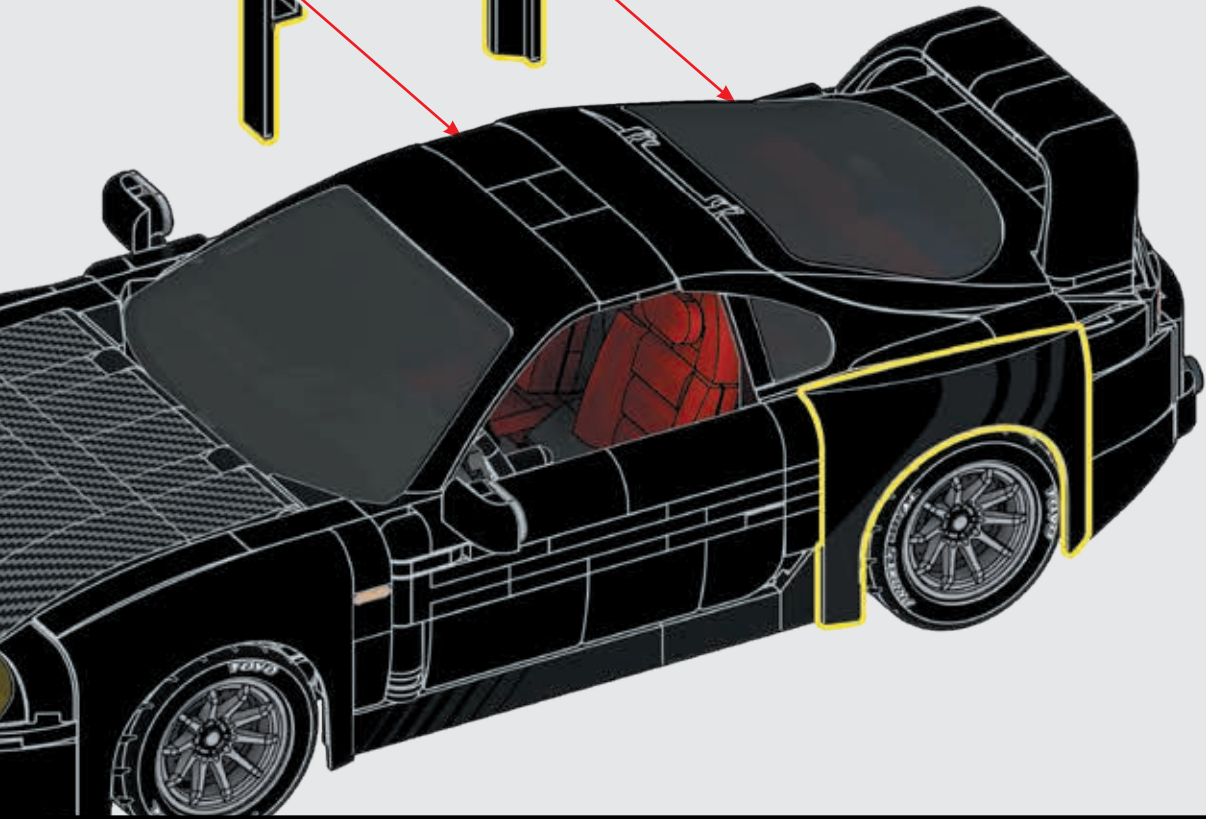
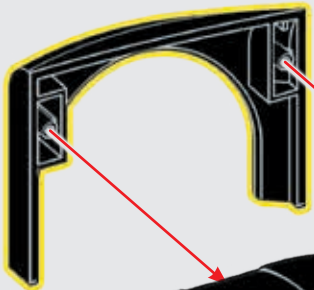
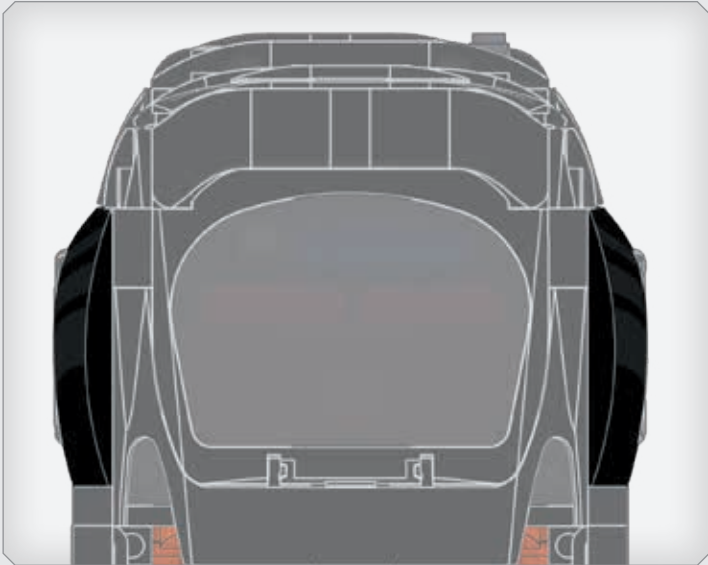
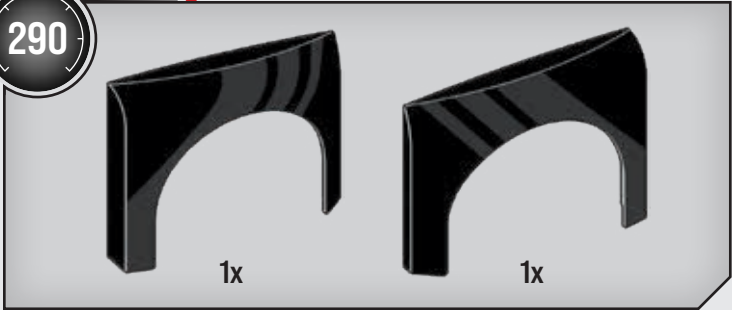

291



1x

As part of this exclusive build, the metal signature plate features a matte black finish. It doubles as a keychain!

Pour cette construction noire exclusive, la plaque de signature en métal présente une finition noire mate. Elle peut également servir de porte-clés!

Como parte de este diseño negro exclusivo, hemos creado una matrícula distintiva con un acabado negro mate. ¡También puede usarse como llavero!

Als Teil dieser exklusiven schwarzen Ausführung wurde das „Signature Plate“ aus schwarzem Metall gegossen. Es dient gleichzeitig als Schlüsselanhänger! Es dient gleichzeitig als Schlüsselanhänger!

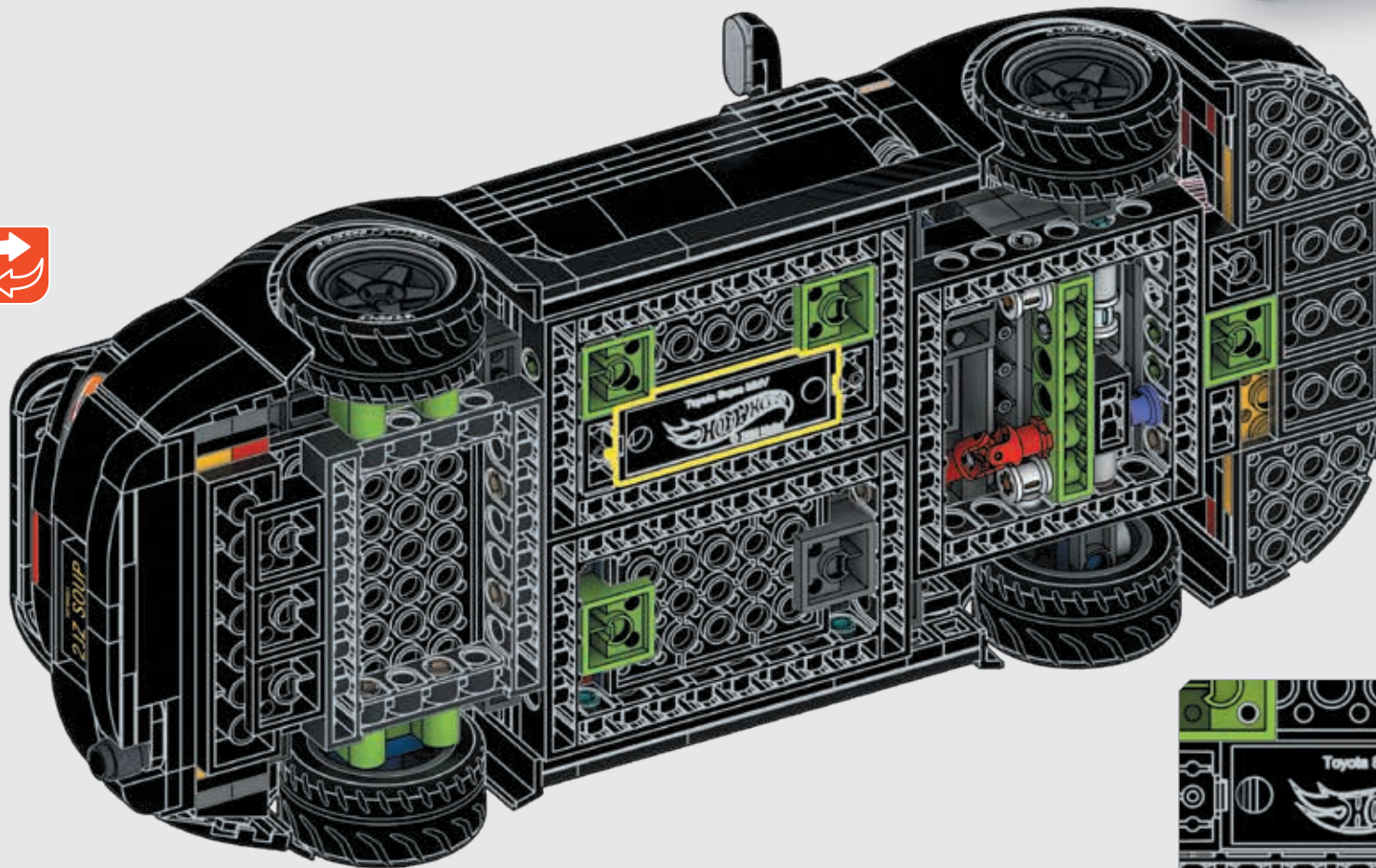

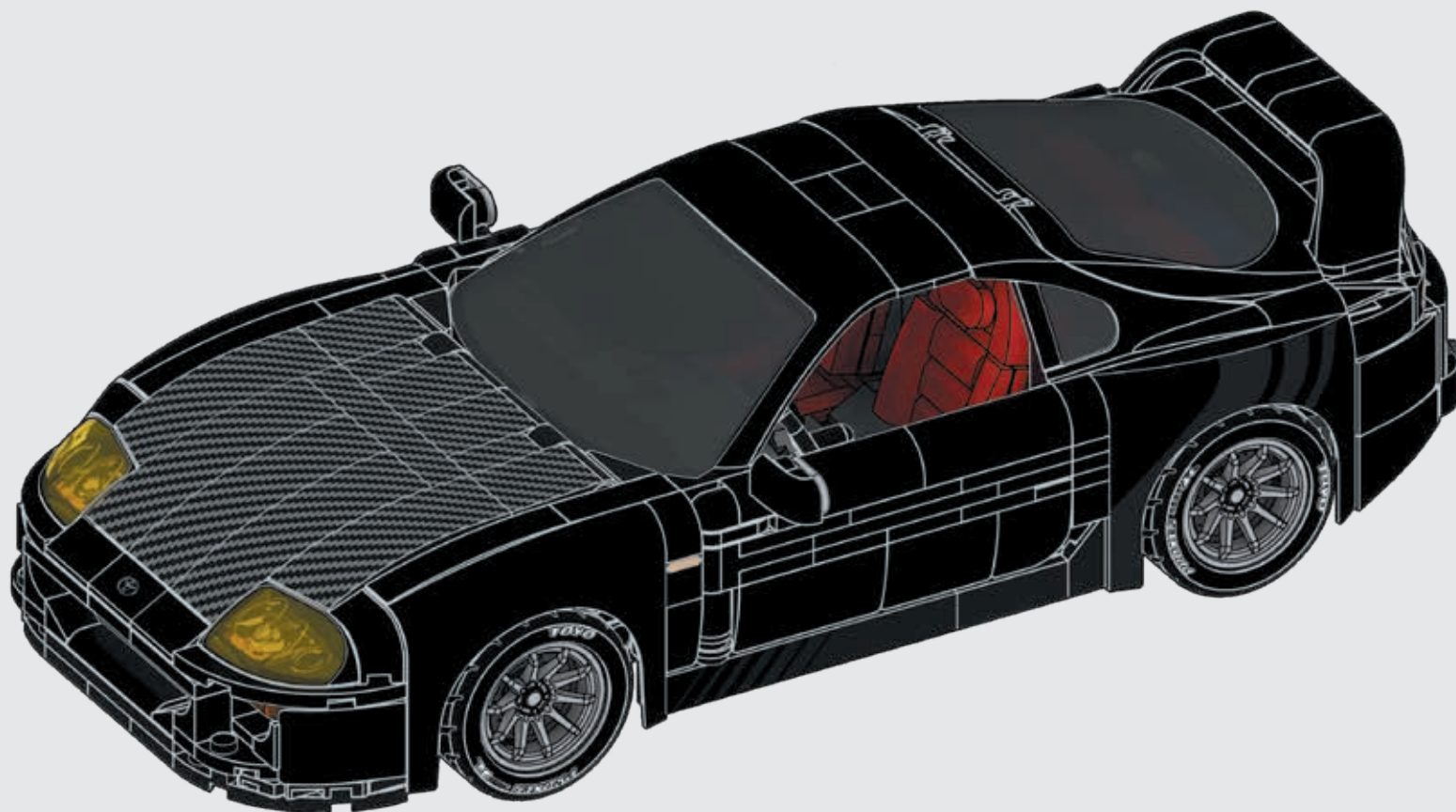

You've completed your '94 Toyota Supra MKIV!
Notice extra pieces? Don't worry – we included those in case any get misplaced!

¡Has completado tu '94 Toyota Supra MKIV!
¿Detectas piezas adicionales? No te preocupes. Las hemos incluido en caso de que se extravíe alguna.

Vous avez complété votre '94 Toyota Supra MKIV!
Vous remarquez des pièces supplémentaires ? Ne vous inquiétez pas : nous les avons inclus au cas où certaines pièces se perdraient quelque part.

Du hast den Bau deines '94 Toyota Supra MKIV fertiggestellt!
Zusätzliche Teile gefunden? Keine Sorge – wir haben sie hinzugefügt, falls welche verloren gehen!

The doors open & close for authenticity!

Les portes s'ouvrent et se ferment pour plus d'authenticité !

¡Las puertas se abren y se cierran para aumentar la sensación de autenticidad!

Die Türen lassen sich für Authentizität öffnen und schließen!

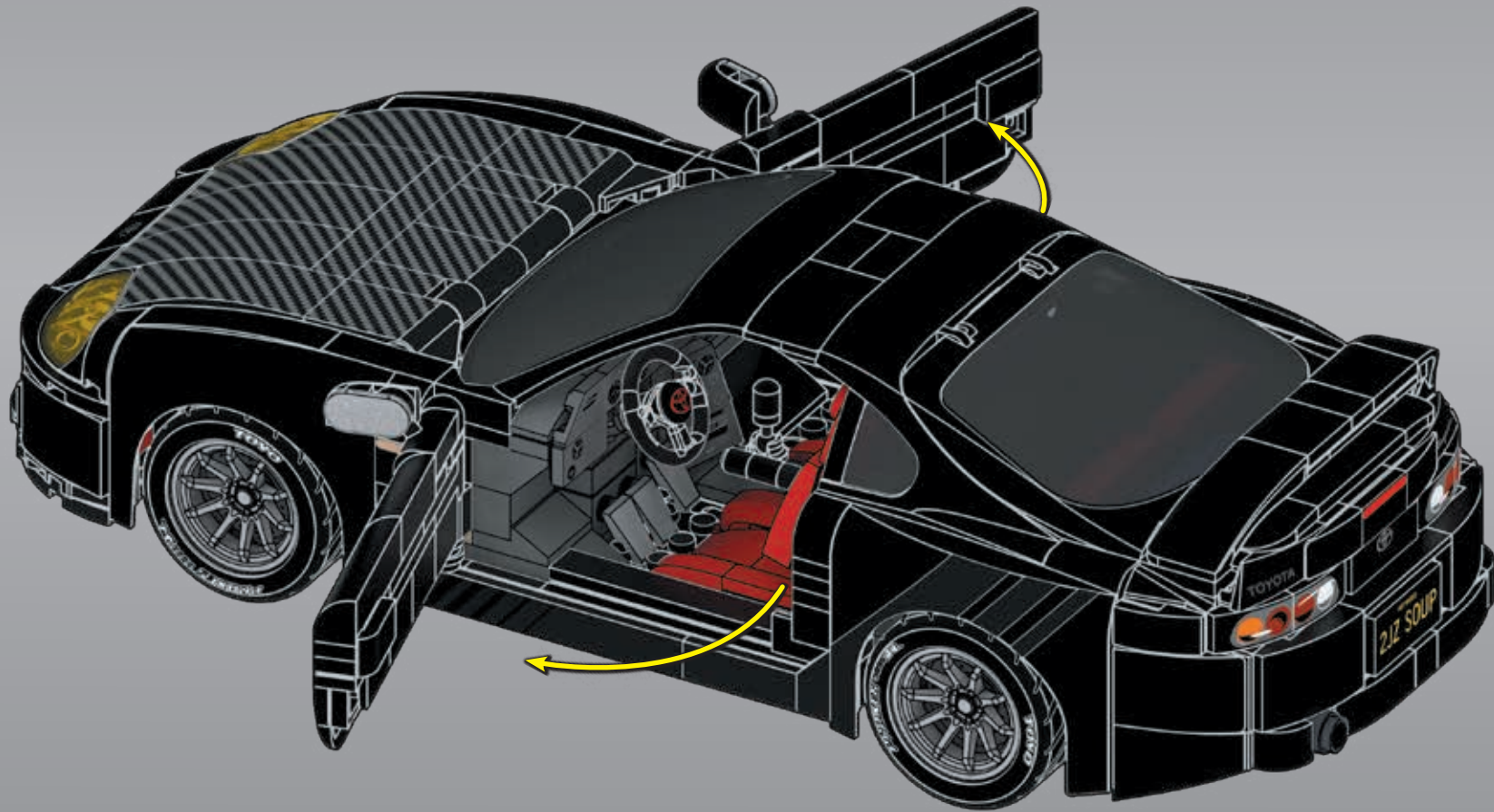

Notice the functional steering? Our design team included it as part of our commitment to realism.

Remarquez la direction fonctionnelle ? Notre équipe de design l'a ajoutée dans le cadre de notre engagement envers le réalisme.

¿Notas la dirección funcional? Nuestro equipo de diseño la incluyó como parte de nuestro compromiso con el realismo.

Bemerken Sie die funktionale Lenkung? Unser Designteam hat sie als Teil unseres Engagements für Realismus integriert.

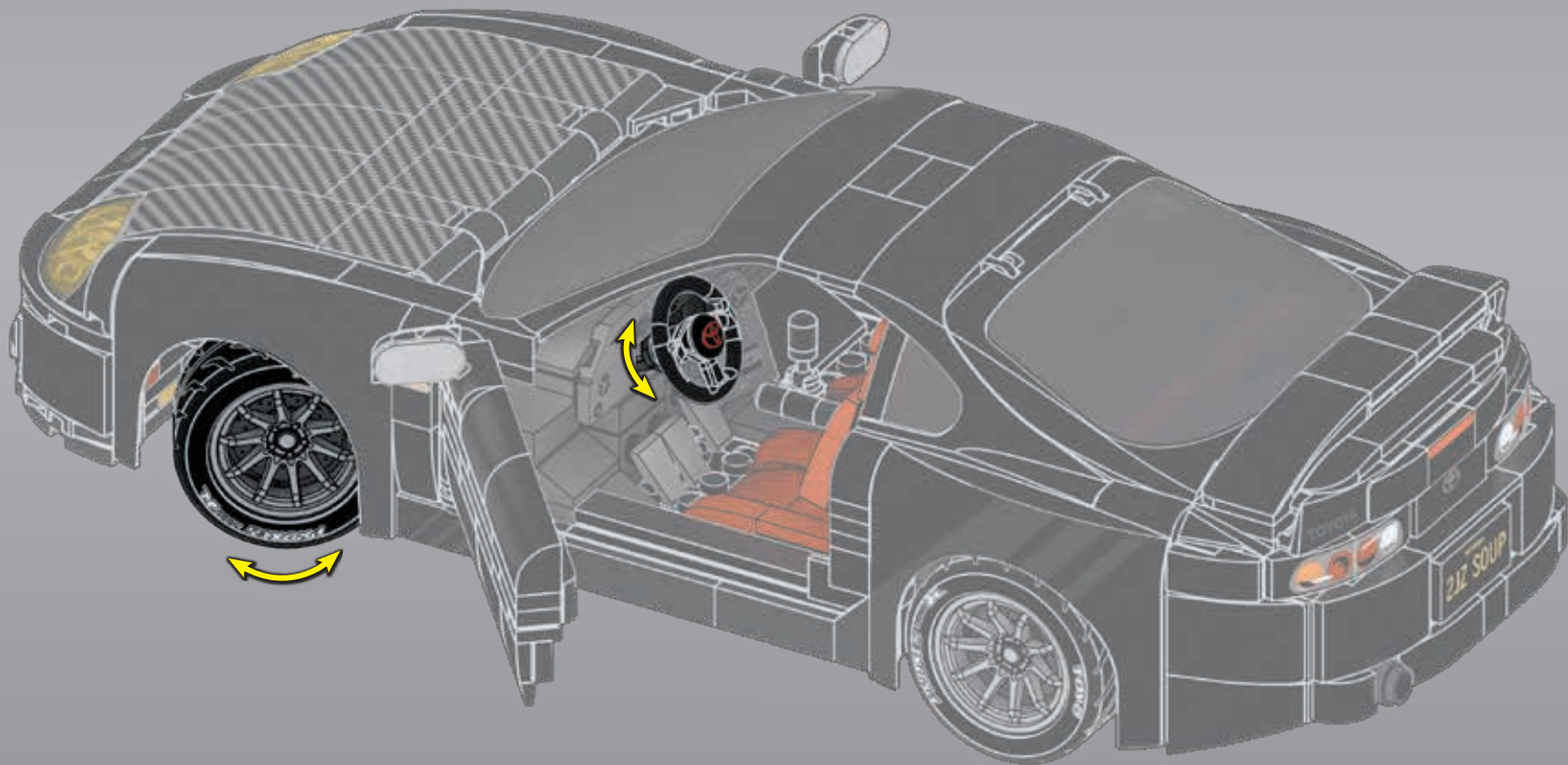

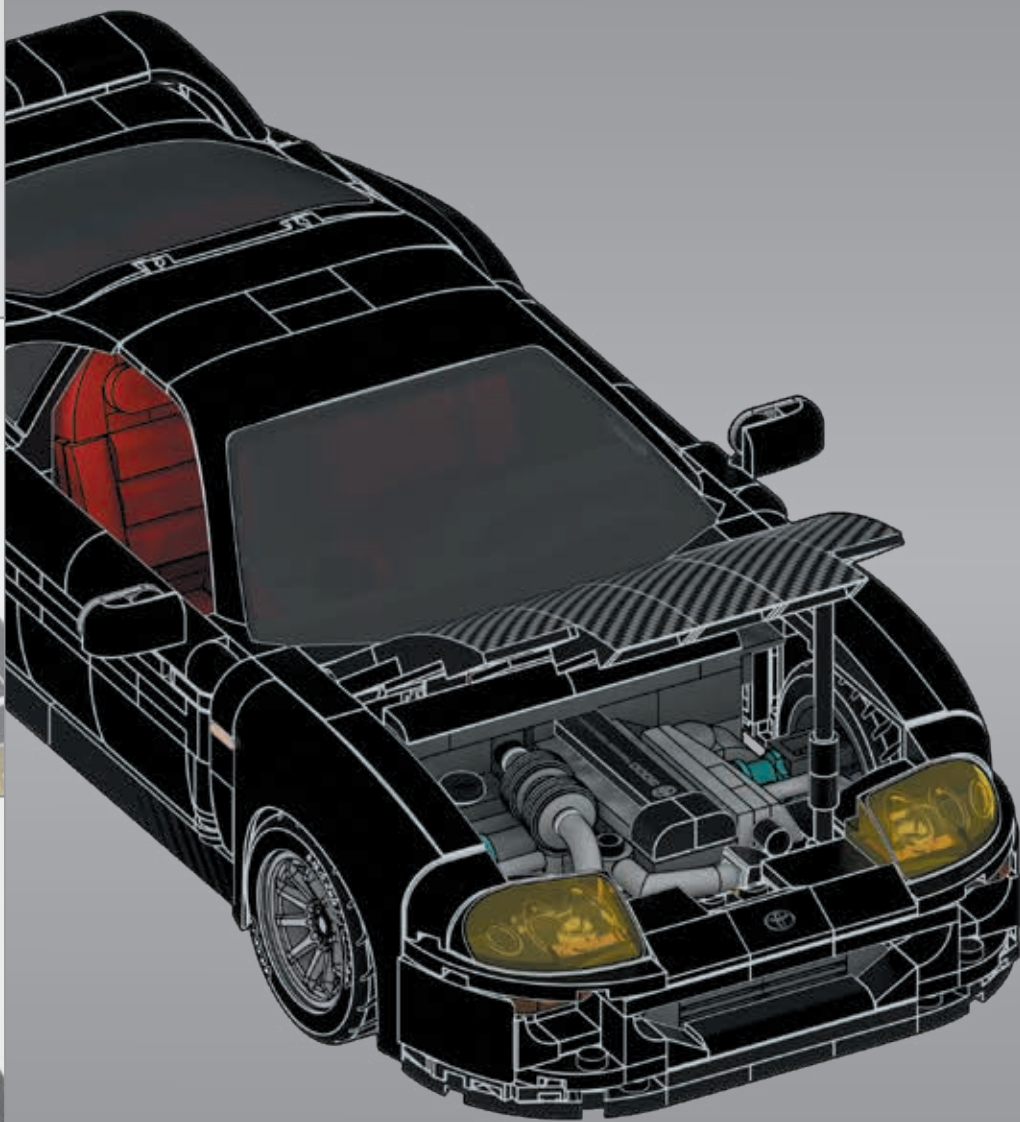
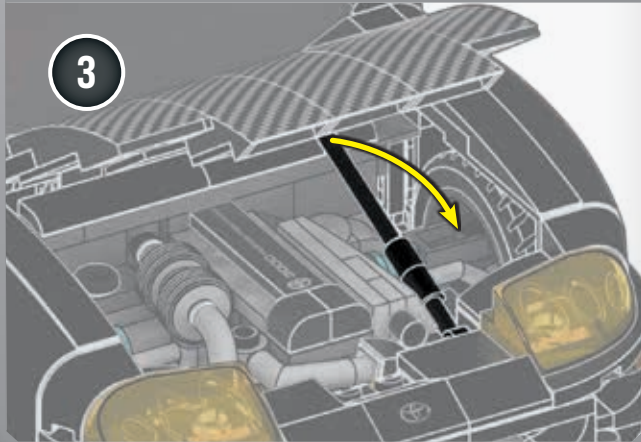
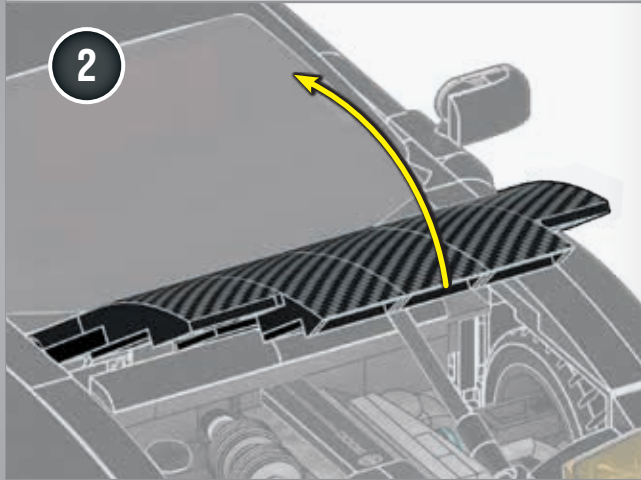
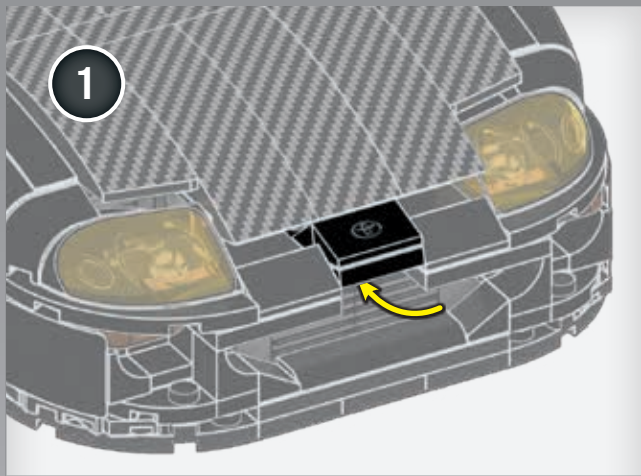

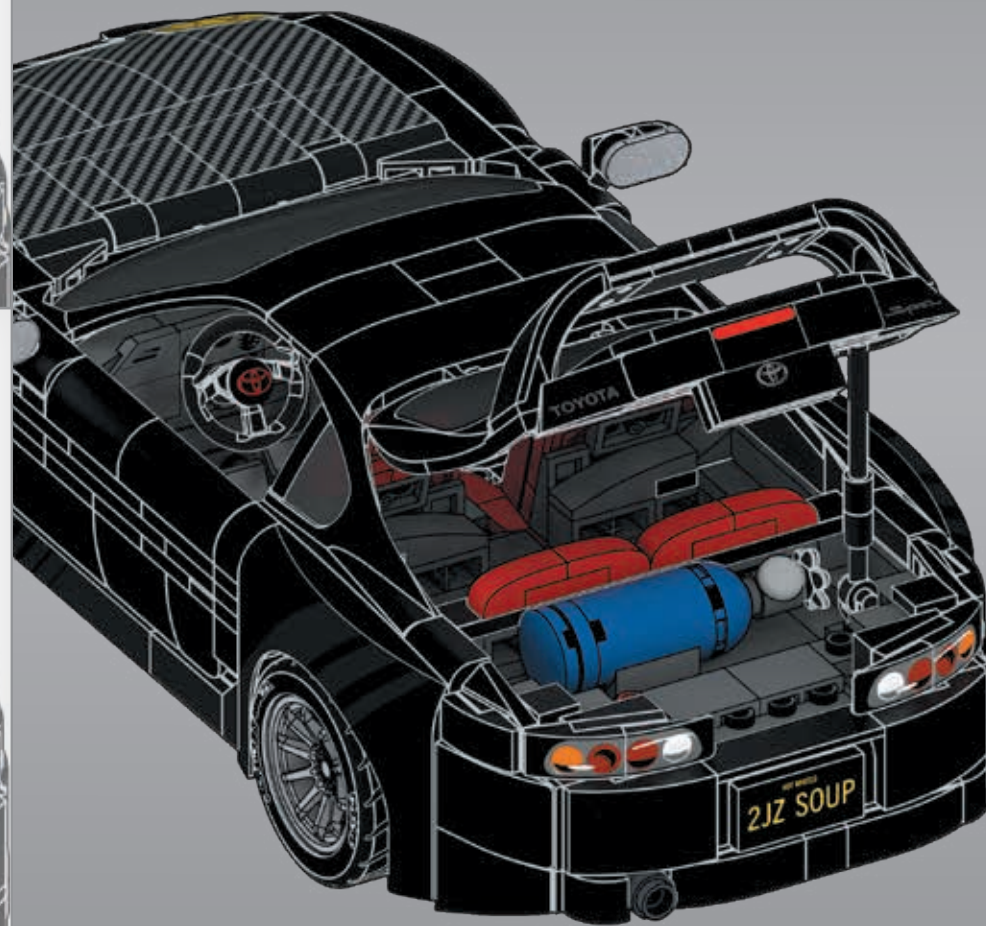
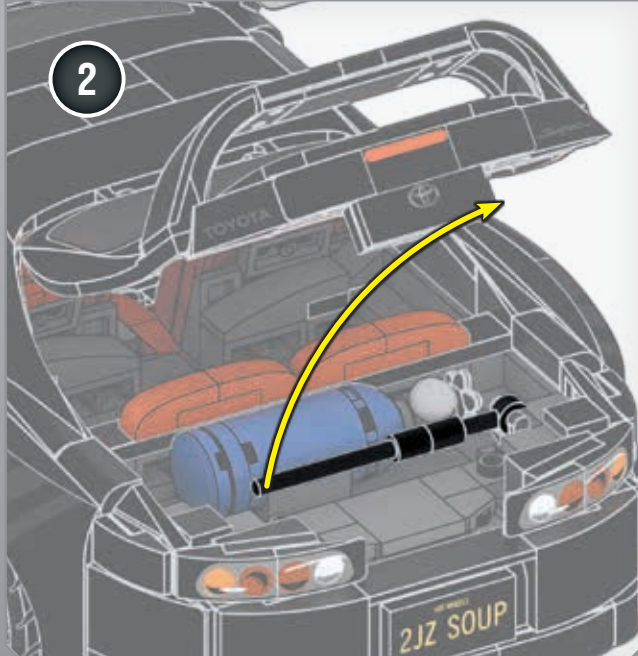
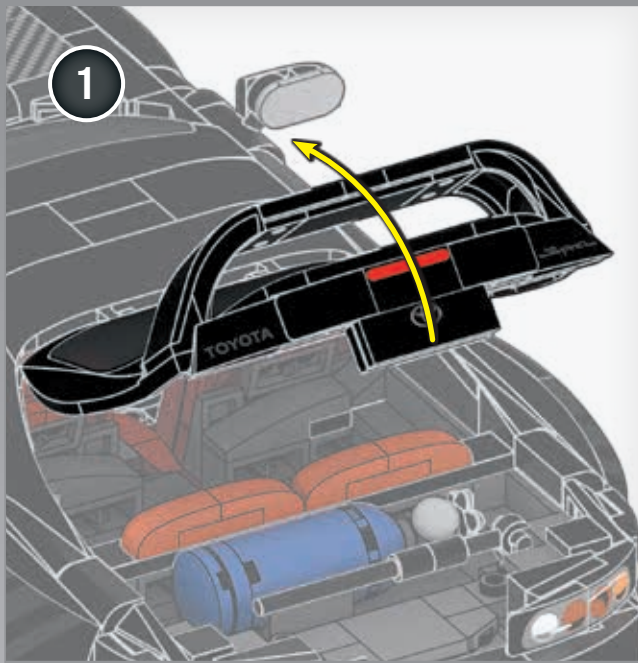

CUSTOMIZE YOUR CAR / PERSONNALISEZ VOTRE VOITURE

PERSONALIZA TU COCHE / DAS AUTO INDIVIDUELL GESTALTEN



Most models can be built one at a time. / La plupart des modèles peuvent être construits un à la fois. / La mayoría de modelos se pueden construir de uno en uno. / A maioria dos modelos pode ser construída separadamente. / La maggior parte dei modelli possono essere realizzati uno per volta. / Die meisten Modelle können eines nach dem anderen gebaut werden. / Większość modeli nie da się budować jednocześnie z innymi. / De meeste modellen kunnen één voor één gebouwd worden. / Большинство моделей могут быть собраны по одной за раз. / De fleste modeller kan bygges enkeltvis. / De flesta modeller kan byggas en i taget. / De fleste modellene kan bygges en om gangen. / Useimmat mallit voidaan rakentaa yksi kerrallaan. / Majoritatea modelelor pot fi construite unul câte unul. / Το περισσότερο μοντέλα μπορούν να κατασκευασθούν ένα ένα. / Modellerein çoğu ayrı ayrı inşa edilmeyi gerektirebilir. / Väčšina modelov môže byť zostavená iba raz. / A modellek többségéből egyszerre csak egy építhető. / Більшість моделей можна збирати по одній. / ほとんどのモデルは、一度に一つを組み立てることができます。 / 大多数型号可一次性建构。 / يمكن تركيب التصميم الواحد تلو الآخر.

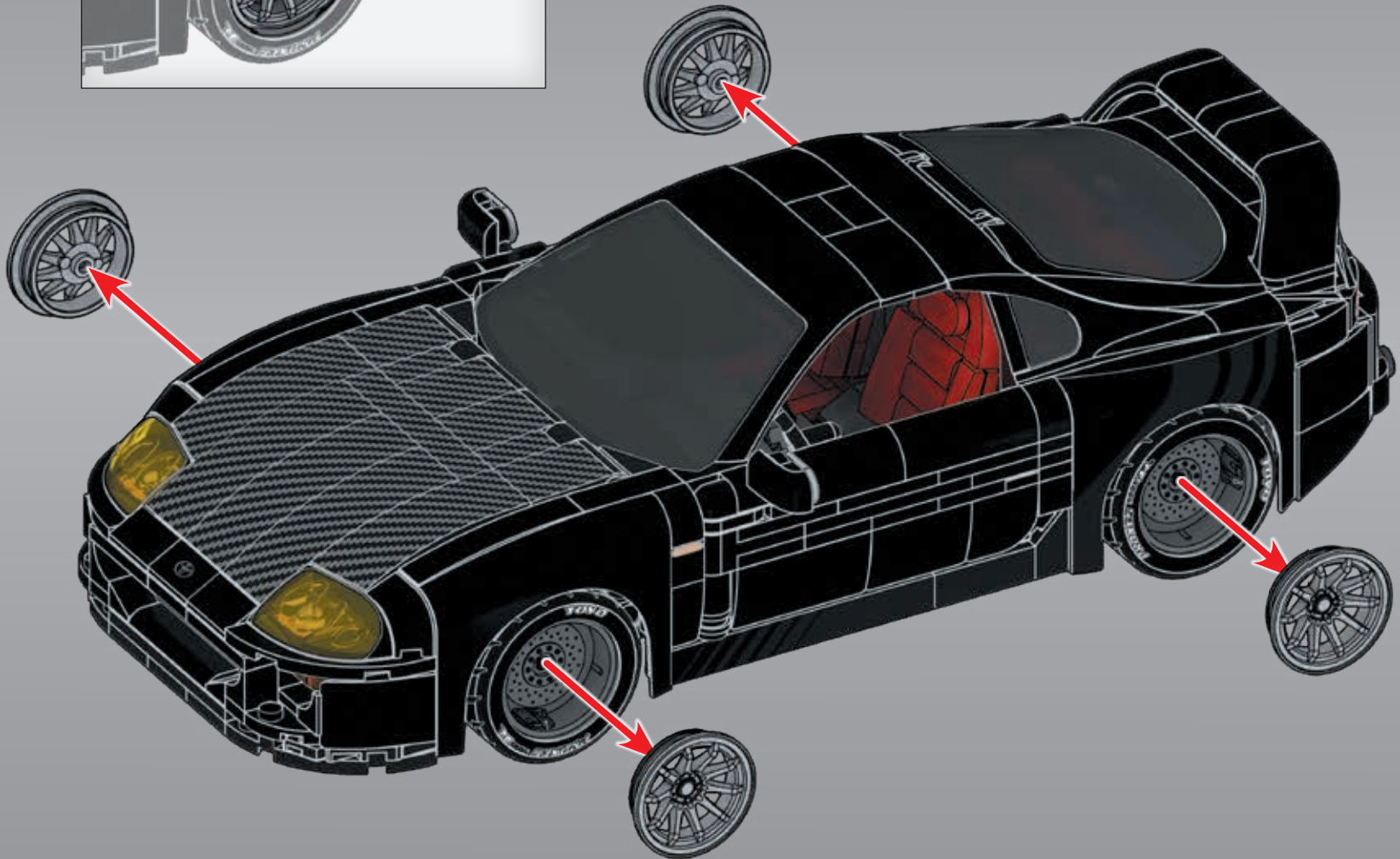
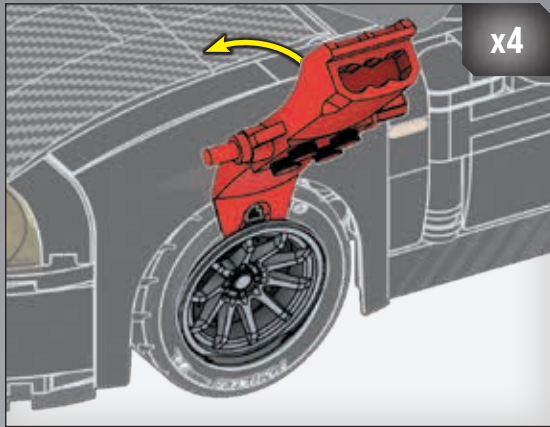

293



4x

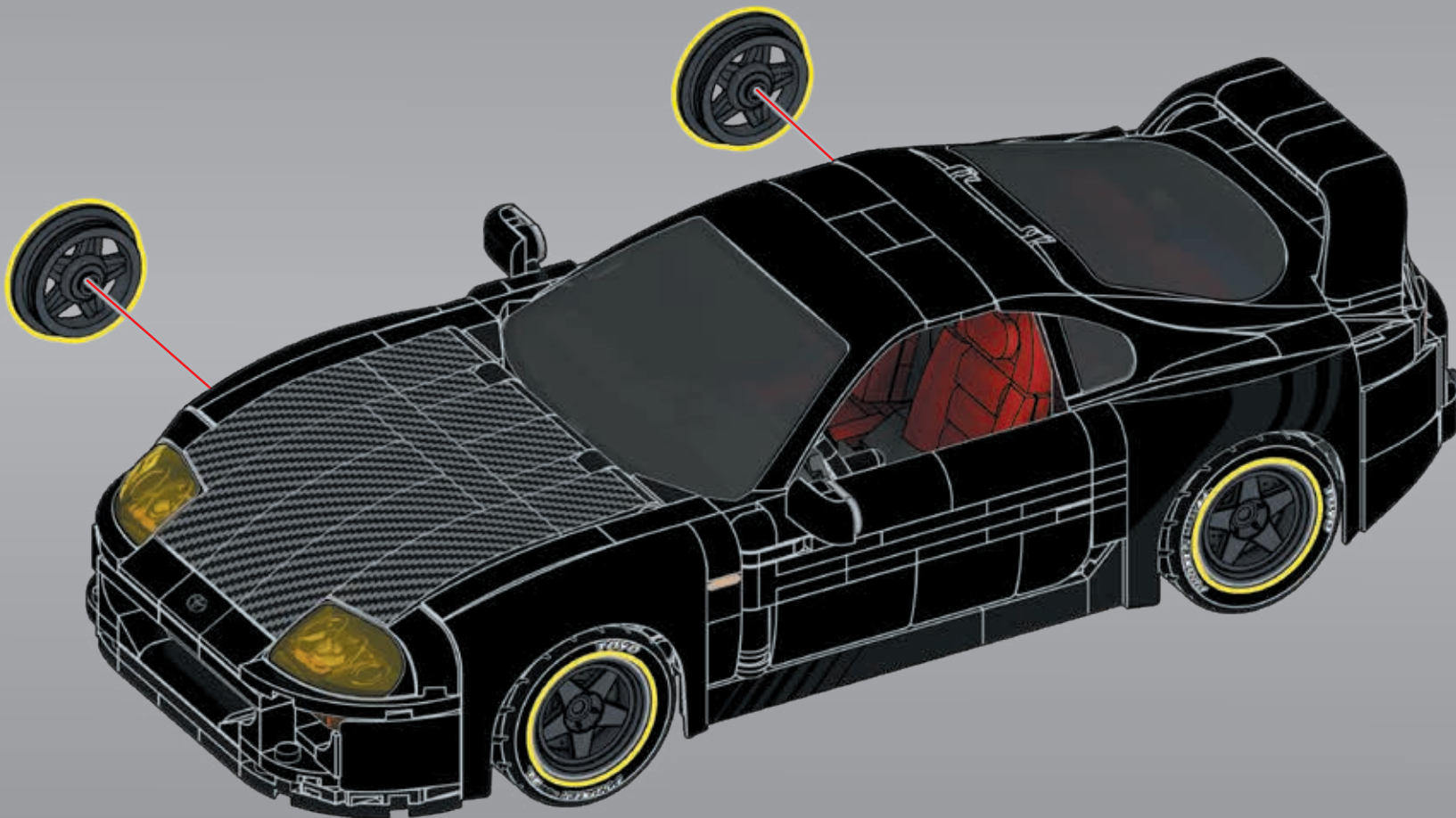

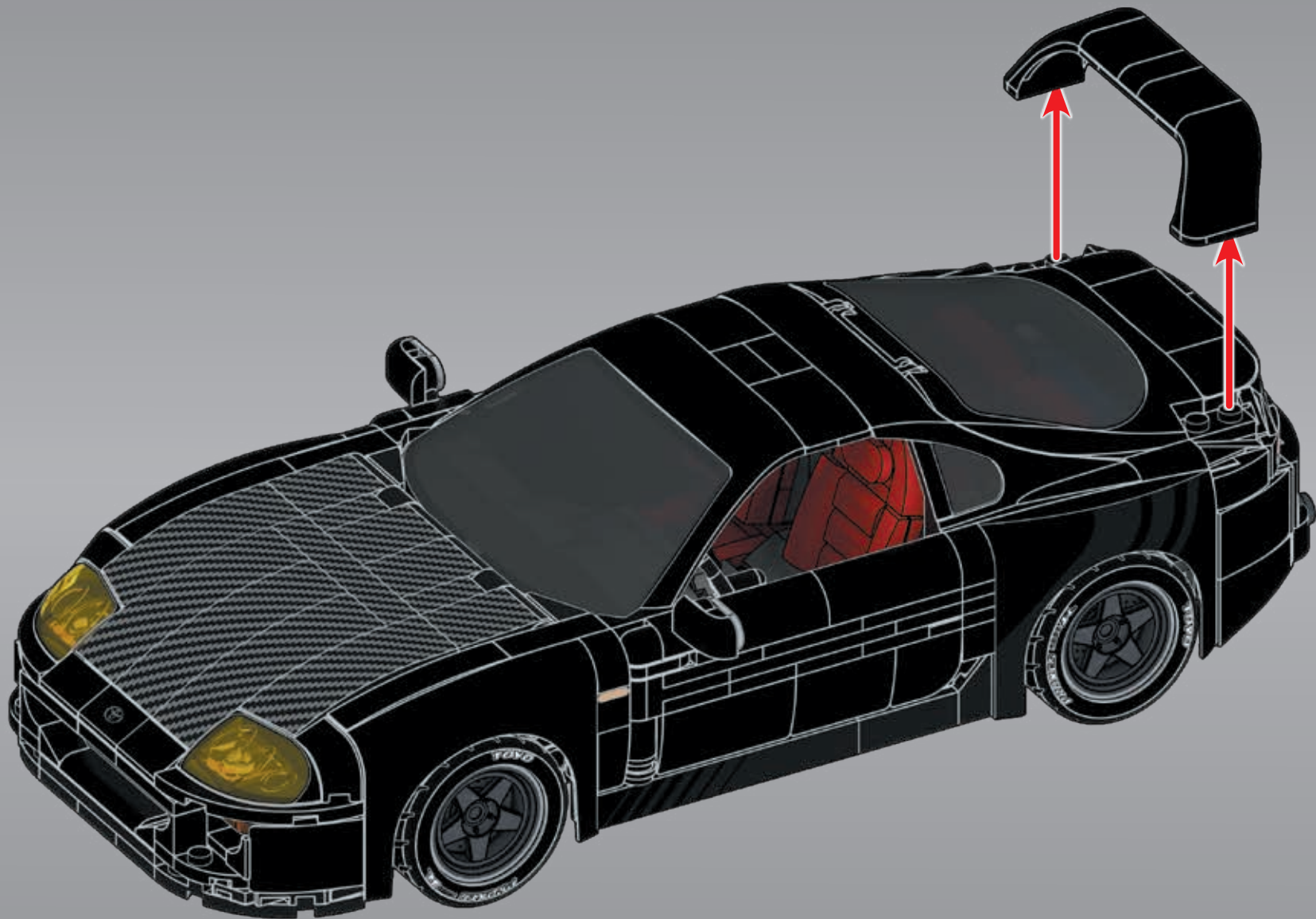

295

2x4



1x

1x6



2x

2x8



1x

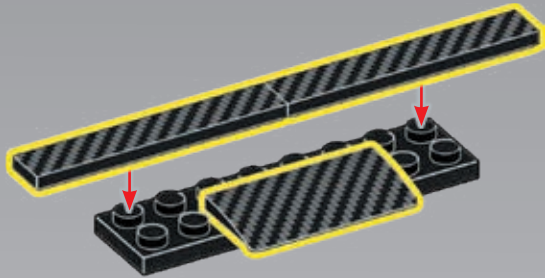

296

2x4



2x

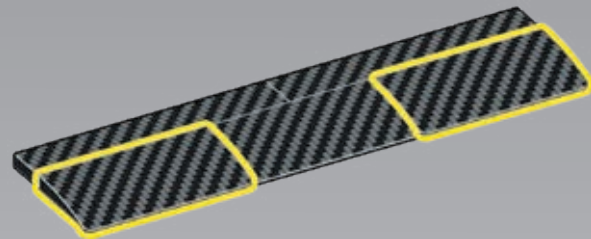

297



2x

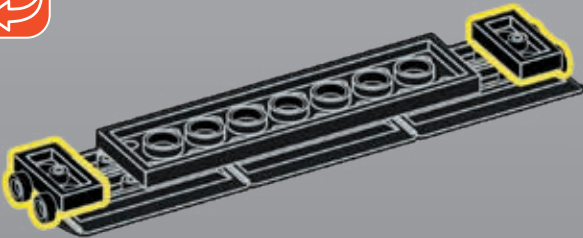

298



2x

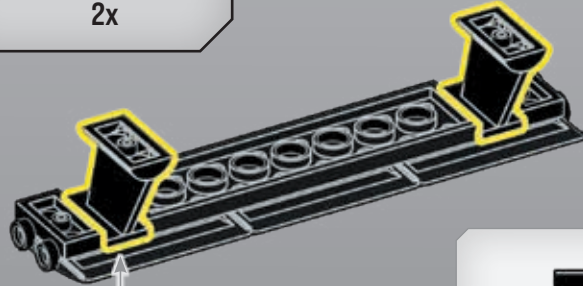

299



1x

1x

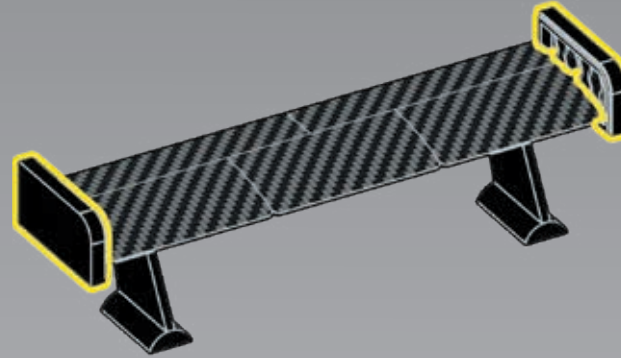

300

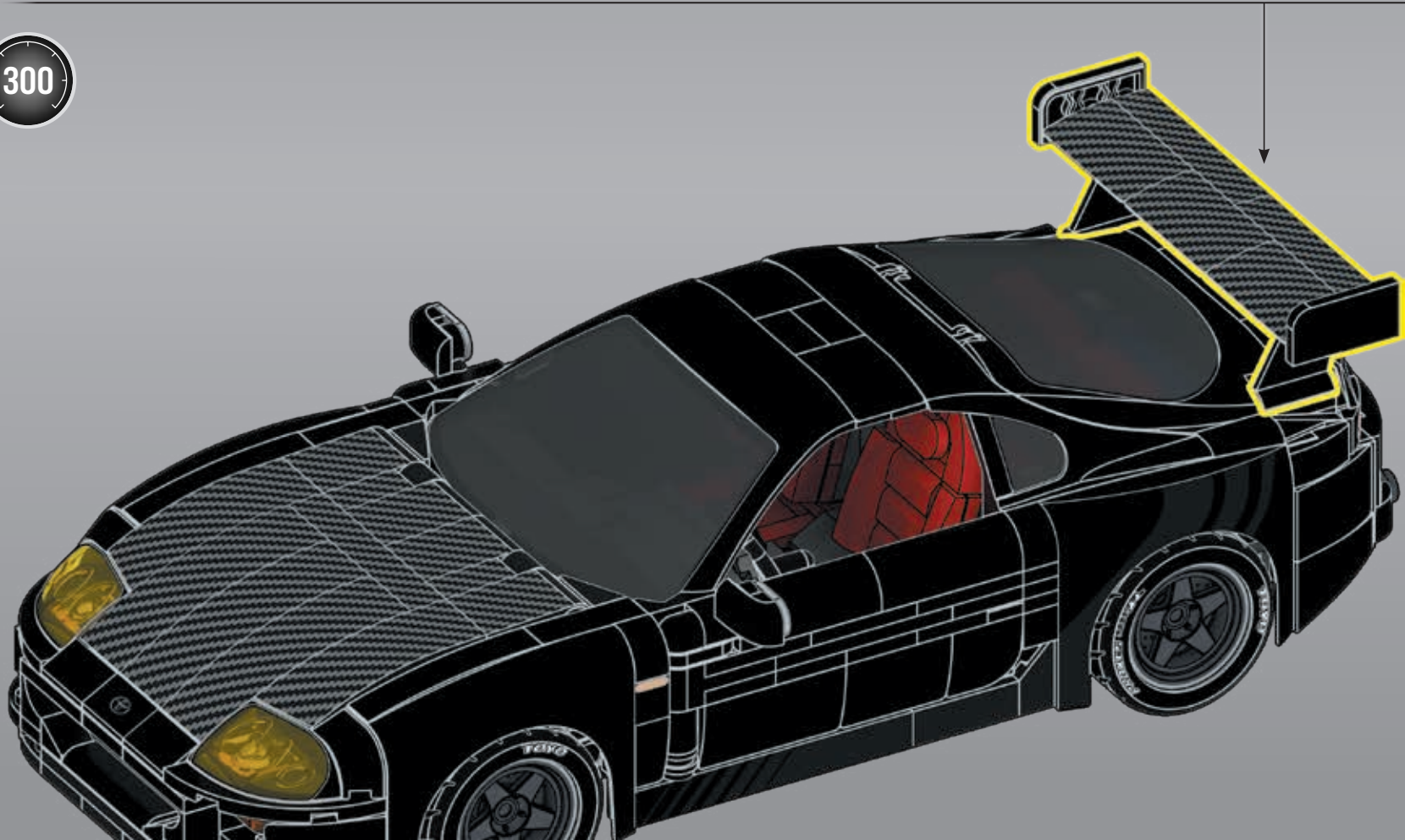

301



2x

2x6

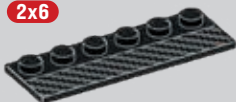

5x

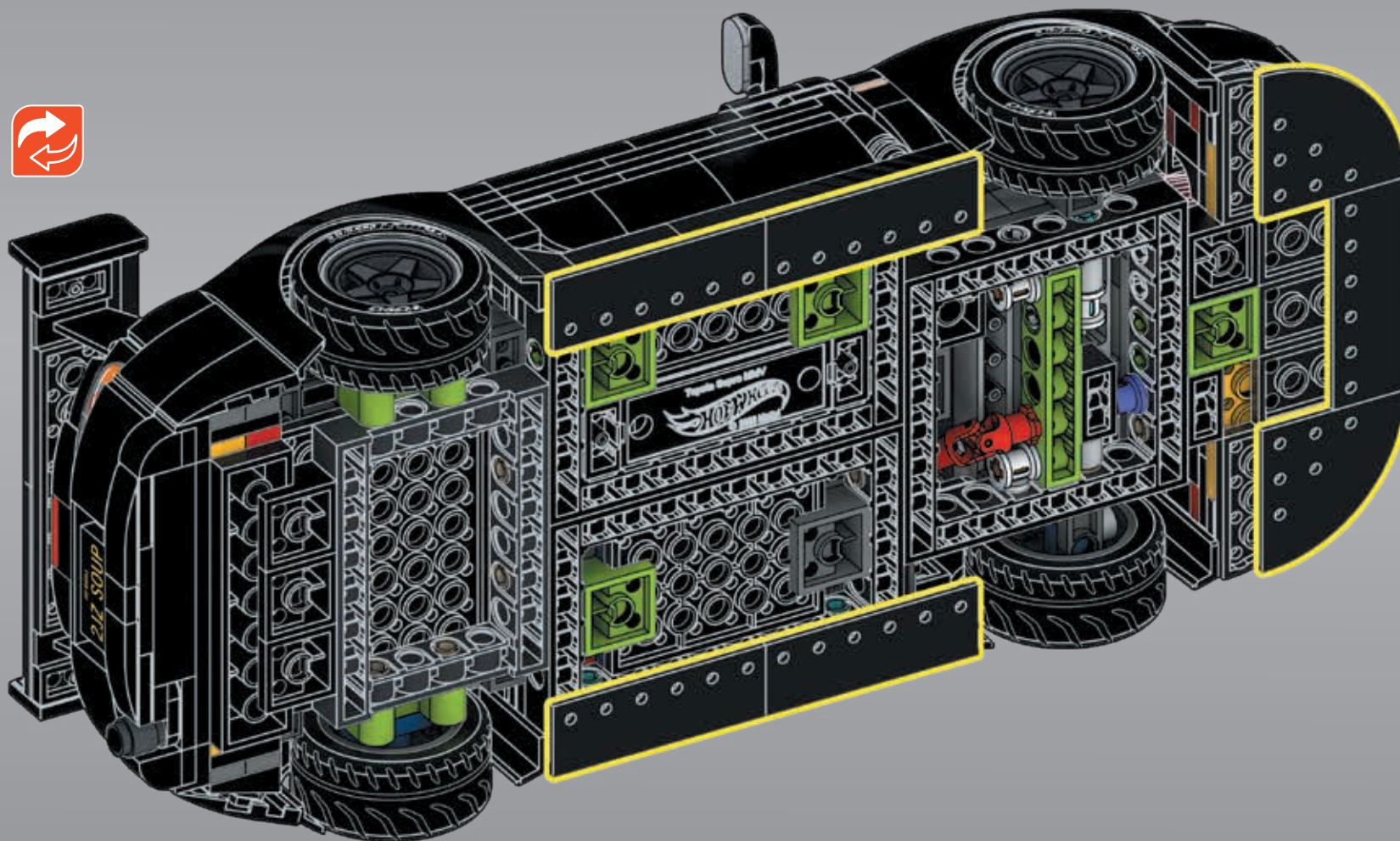

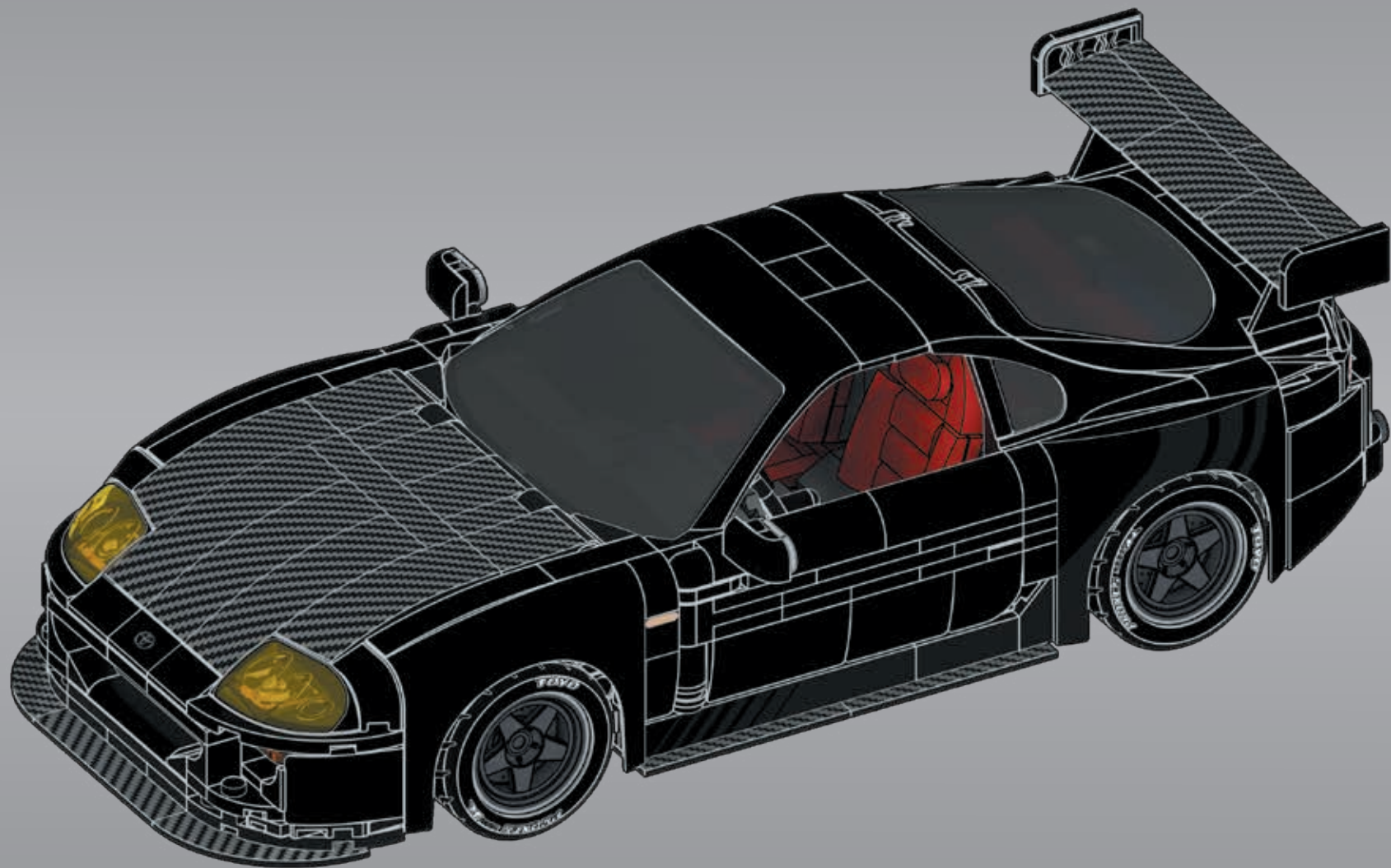

MAKE IT YOUR OWN WITH **DECALS**

PERSONNALISEZ-LA AVEC DES **AUTOCOLLANTS**

PERSONALÍZALO CON PEGATINAS / MIT AUFKLEBERN INDIVIDUELL GESTALTEN

We've included officially licensed decals of Toyota, Brembo, Sparco, Motul, K&N, Greddy, RAYS and Toyo Tires to finish off your ride. You can customize your ride the way you like.

Nous avons inclus des autocollants Toyota, Brembo, Sparco, Motul, K&N, Greddy, RAYS et Toyo Tires sous licence officielle. Vous pouvez ainsi personnaliser votre bolide à votre guise.

Hemos incluido pegatinas con licencia oficial de Toyota, Brembo, Sparco, Motul, K&N, Greddy, RAYS y Toyo Tires. Puedes personalizar tu coche como más te guste.

Mitgeliefert werden offiziell lizenzierte Toyota, Brembo, Sparco, Motul, K&N, Greddy, RAYS und Toyo Tires. So lässt sich der Rennwagen ganz individuell gestalten.

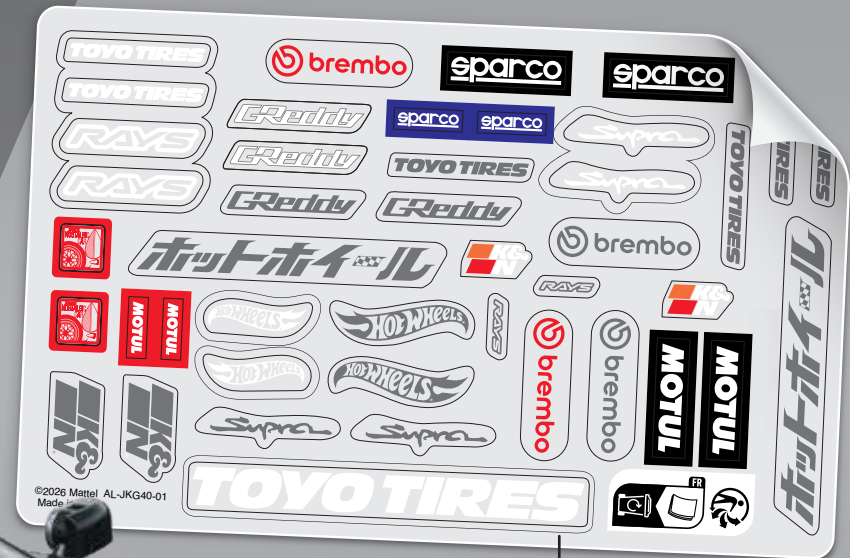



THIS IS HOW WE PLACED THE DECALS. WHERE WILL YOU PLACE THEM?

VOICI COMMENT NOUS AVONS PLACÉ LES AUTOCOLLANTS.

OÙ ALLEZ-VOUS LES PLACER?

ASÍ ES COMO UBICAMOS LOS AUTOADHESIVOS. ¿DÓNDE LOS COLOCARÍAS?

DAS IST EINE MÖGLICHKEIT, DIE AUFKLEBER ANZUBRINGEN.

WO WERDEN SIE DIESE PLATZIEREN?





3x
ME77583F

3x
ME74397F

2x
ME74397BLG

1x
ME74397BYE

2x
ME77341BLG

4x
ME75332BLG

1x
ME75332BDG

1x
ME75332F

1x
AS-JKG40-26

4x
ME0113BDG

6x
ME0113F

1x
AM15026F

1x
ME75175F

1x
ME82782BDG

1x
ME82783BDG

3x
ME07223BDG

7x
ME07223F

1x
ME82819BDG

2x
ME82855F

3x
ME03328BLG

8x
ME03328AMC

2x
ME03328BDG

15x
ME03328F

2x
ME81529AMC

2x
ME091048YE

4x
ME79665F

8x
ME79590F

5x
ME79590AMC

2x
ME77574BLG

1x
ME77574BDG

2x
ME82895F

3x
ME17787LP

4x
ME17787AMC

6x
ME17127BDG

2x
ME17127F

2x
ME82526F

6x
ME83004BDG

4x
ME82744ASU

2x
ME81712ASU

1x
ME81712BDG

1x
ME73334MM

2x
ME80722BDG

9x
ME83318F

1x
ME07659BLG

6x
ME07659F

1x
ME01086E

4x
ME01086BDG

2x
ME01086F

1x
ME07629BDG

3x
ME17003F

1x
ME79403BLG

1x
AM19319F

1x
ME76060F

1x
ME01312BLG

2x
ME01312F

1x
ME01140BLG

2x
ME19328F

2x
ME82403LP

2x
ME82404LP

1x
ME74299LP

1x
ME74300LP

1x
ME81545BDG

4x
ME17018AMC

1x
ME16303ZX

6x
ME77909BLG

3x
ME18240BLG

1x
ME82349F

1x
ME82349BDG

1x
ME82349LP

1x
AS-JKG40-06

2x
ME82348F

1x
ME82348BDG

1x
ME82348LP

1x
AS-JKG40-08

2x
AS-82746-SLV01

2x
ME82100AMC

7x
ME80174F

1x
ME81020F

1x
ME17506BLG

2x
ME81433E

5x
ME82764MY

2x
ME82762ASU

13x
ME82742BTN

2x
ME81438BTN

1x
ME74645BLG

3x
ME82765E

2x
ME77206F

2x
ME82853BDG

4x
ME82524F

1x
AS-JKG40-17

1x
AS-JKG40-18

3x
ME82871F

2x
ME22501AMC

7x
ME22501BDG

3x
ME22501F

1x
AS-JKG40-05

1x
AS-JKG40-07

1x
AS-JKG40-27

2x
ME83396LP

10x
ME82818AMC

6x
ME07590BDG

6x
ME73758F

8x
ME09393BTN

12x
ME09393AMC

8x
ME09393BDG

14x
ME09393F

2x
ME09393LP

2x
ME79246BDG

1x
ME82542BDG

2x
ME79070F

2x ME79070AMC
 2x ME79070BDG
 2x ME76467F
 2x ME76467BDG
 4x ME83417BDG
 4x ME83417F
 1x AS-JKG40-15
 1x AS-JKG40-16
 3x ME18272BDG
 1x ME15480F
 1x ME15481F
 4x ME17128AMC

10x ME80573F
 5x ME80573BDG
 2x ME82538F
 8x ME83320F
 3x ME18014F
 2x ME07228BDG
 2x ME82874F
 1x ME01417BDG
 4x ME17788AMC
 2x ME03017AMC
 2x ME03017F

2x ME82832F
 1x ME18549BDG
 3x ME18549F
 1x AS-JKG40-22
 6x ME82815AMC
 6x ME82816AMC
 1x ME82815F
 1x ME82816F
 1x ME83303F
 1x ME83304F
 2x ME81428LP

2x ME81095BDG
 3x ME09013BDG
 2x ME09013F
 1x ME79877BDG
 2x ME79878F
 1x ME18601BDG
 7x ME17502BDG
 2x ME17502F
 1x ME83325MEP
 2x ME83309F

1x ME02215B
 1x ME19380B
 1x ME04245B
 1x ME16972NU
 2x AM16972KC
 4x ME74428BDG
 2x ME74428LP
 9x ME15484BDG
 6x ME15484AMC
 2x ME82883BDG
 2x ME82244AMC
 2x ME82521F

2x ME00948AMC
 2x ME00948F
 1x ME82707BDG
 2x ME81476BDG
 3x ME03773F
 1x ME03773BDG
 1x ME78189BDG
 2x ME83313F
 2x ME83314F
 2x ME74106AMC

1x ME17601B
 1x ME17153F
 1x AS-JKG40-13
 3x ME01154BDG
 1x ME09023BLG
 1x ME09023BDG
 1x ME82631F
 2x ME8330BYE
 1x ME79876ASU
 2x AS-JKG40-31

2x ME82566F
 1x AS-JKG40-19
 3x ME80966F
 1x ME80966BDG
 2x ME80966LP
 7x ME01314AMC
 13x ME01314BDG
 6x ME01314F
 2x ME83321BDG
 5x ME81259BYE
 2x ME81260ASY
 6x ME80143F

1x AS-JKG40-10
 2x ME82278F
 2x ME82560BDG
 1x AS-JKG40-21
 1x AS-JKG40-20
 2x ME82779AMC
 2x ME82780AMC
 2x ME82930B
 2x ME83367JS
 2x ME83326F

1x ME16384BLG
 1x ME16384BDG
 4x ME78107F
 2x ME83322F
 2x ME76521F
 1x ME80223BLG
 4x ME82604JS
 1x ME82604BDG
 4x ME82604F
 4x ME83399LP

1x ME82803F
 1x ME82804F
 1x AS-JKG40-09
 1x ME82900AMC
 1x ME82901AMC
 1x ME82851F
 1x ME82852F
 6x ME81604F
 2x ME81639BDG
 1x ME81785F
 1x ME82557F

3x ME03772AMC
 5x ME03772BDG
 2x ME03772F
 1x ME77465F
 4x ME74848LP
 2x ME17021F
 1x ME03873F
 1x ME83310F
 1x ME83311F

4x AS-JKG40-25
 4x AS-83323-BLK01
 1x AS-JKG40-33
 1x AS-JKG40-34
 1x ME18615BDG
 6x ME81163F
 4x AS-JKG40-24
 3x ME82877F

1x ME09838F
 1x AS-JKG40-23
 3x ME09593BLG
 4x ME09593AMC
 8x ME09593BDG
 4x ME09593F
 1x ME83419BDG
 2x ME17521BDG
 1x ME17521F
 1x AS-JKG40-11

1x
ME82698BLG

2x
ME83327F

1x
ME01087BLG

1x
ME01087BYE

1x
ME01087BDG

1x
AS-JK640-12

3x
ME17503BDG

1x
ME03323F

1x
ME03324F

2x
ME82048F

3x
ME83398LP

1x
ME77463F

1x
ME01531BLG

4x
ME09493AMC

5x
ME09493B

1x
ME09493BDG

1x
ME09033BDG

1x
ME81589F

2x
AS-JK640-30

4x
ME07475F

2x
ME07475BDG

2x
ME83319F

1x
ME79705BLG

2x
ME80965BDG

1x
ME80965B

1x
ME83305LP

1x
ME83306LP

2x
ME83316LP

2x
ME83317F

2x
ME74680LP

1x
ME17054F

1x
ME17054BLG

1x
ME16331F

3x
ME83397LP

1x
ME09292BLG

2x
ME09292JS

1x
ME09292BDG

1x
ME09292F

1x
ME09292LP

5x
ME83315LP

1x
ME01313BDG

1x
ME01313F

1x
ME81190JS

1x
AS-83312-BLK02

1x
ME82770F

1x
ME82117F

1x
ME01480BLG

1x
ME01480F

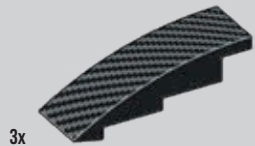

3x
ME83328LP

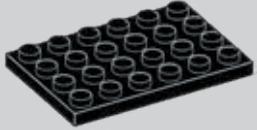

1x
ME17055F

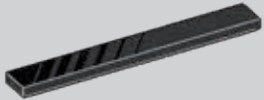

1x
AS-JKG40-02

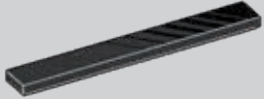

1x
AS-JKG40-01



1x
ME18298BDG



7x
ME18298F

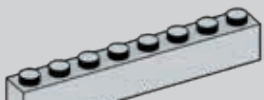

1x
ME10233BLG



2x
ME82757F

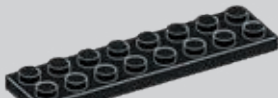

1x
ME08483LP

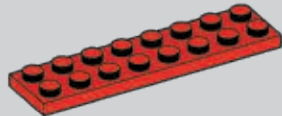

1x
ME08483AMC



1x
AS-JKG40-04



1x
AS-JKG40-03

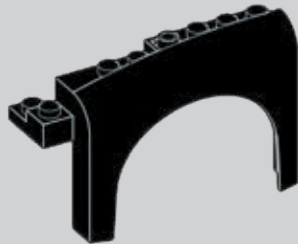

1x
ME83299F



1x
ME83300F



1x
ME80855EA



1x
ME82590F



2x
ME04984F

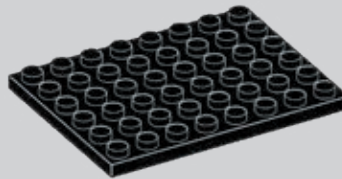

1x
ME74678F

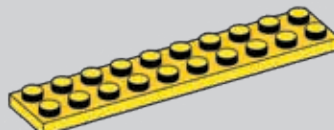

1x
ME09923BYE

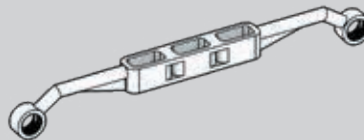

1x
ME83329E

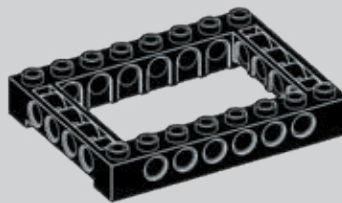

1x
ME82908F

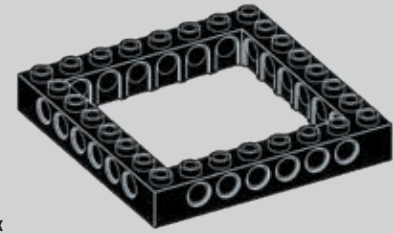

1x
ME82587F

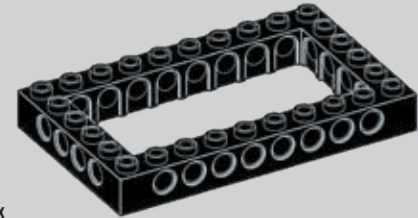

2x
ME82586F

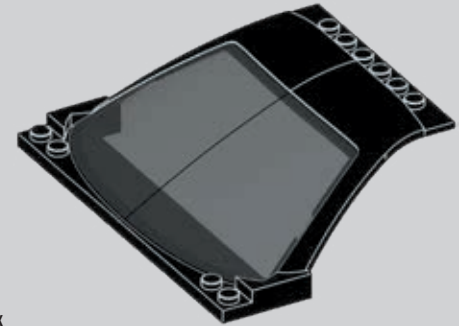

1x
AS-JKG40-28



1x
AS-JKG40-29

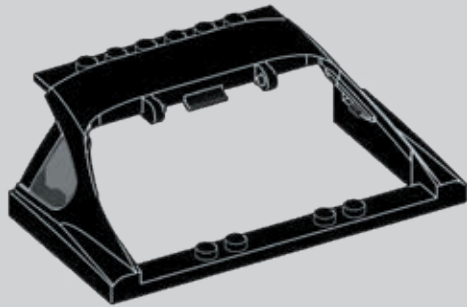

1x
AS-JK640-32



1x
JM53

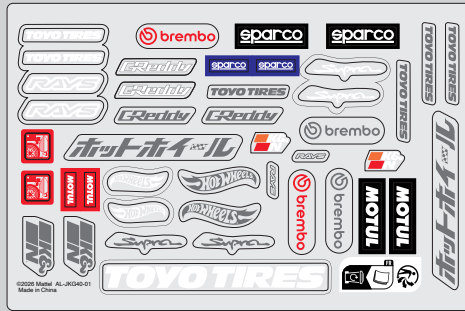

AL-JK640-01

Missing pieces?
Pièces manquantes?
Partes faltantes?
Perdeu peças? • Fehlen Teile?

[? service.mattel.com](http://service.mattel.com)



MATELBRICKSHOP.COM

MADE IN CHINA. VEHICLE MADE IN CHINA, MALAYSIA, INDONESIA OR THAILAND AS MARKED.
FABRIQUÉ EN CHINE. VÉHICULE FABRIQUÉ EN CHINE, EN MALAISIE, EN INDONÉSIE OU EN THAÏLANDE COMME INDIQUÉ.
HECHO EN CHINA. VEHÍCULO HECHO EN CHINA, MALASIA, INDONESIA O TAILANDIA, SEGÚN LO INDICADO.
FABRICADO NA CHINA. VEÍCULO FABRICADO NA CHINA, MALÁSIA, INDONÉSIA OU TAILÂNDIA, CONFORME INDICADO.
ИЗГОТОВЛЕНО В КИТАЕ. АВТОМОБИЛЪ ИЗГОТОВЛЕН В КИТАЕ, МАЛАЙЗИИ, ИНДОНЕЗИИ ИЛИ ТАИЛАНДЕ СОГЛАСНО МАРКИРОВКЕ.
ÇİN'DE ÜRETİLMİŞTİR. ARAÇ, BELİRTİLDİĞİ ŞEKİLDE ÇİN, MALEZYA, ENDONEZYA VEYA TAYLAND'DA ÜRETİLMİŞTİR.
صنعت في الصين. صنعت السيارة في الصين أو ماليزيا أو اندونيسيا أو تايلاند كما هو مذكور.

Mattel Europa B.V., Gondel 1, 1186 MJ Amstelveen, Nederland. Mattel U.K. Limited, The Porter Building, 1 Brunel Way, Slough SL1 1FQ, UK. Mattel Barbie (Shanghai) Trading Co., Ltd. Room 2005, 20th Floor, 899 Ruining Road, Xuhui District, Shanghai, 200232, PRC. Customer Care Line: 400-819-8658. Kids Kingdom Limited, Room 1908-9, Gala Place, 56 Dundas Street, Mongkok, Kowloon, Hong Kong, P.R.C. Customer Care Line: (852)2782-0766. CHICKABIDDY CO., LTD, F5, No. 186, Sec. 4, Nanjing E. Rd., Taipei 10595, Taiwan region. Customer Care Line: 0800 001 256. Diimport & Diedarkan Oleh: Mattel Continental Asia Sdn Bhd. Level 19, Tower 3, Avenue 7, No. 8 Jalan Kerinchi, Bangsar South, 59200 Kuala Lumpur, Malaysia. Mattel South Africa (PTY) LTD, Office 102 I3, 30 Melrose Boulevard, Johannesburg 2196. Mattel Australia Pty. Ltd., 658 Church St., Richmond, Victoria, 3121. Consumer Advisory Service - 1300 135 312. Mattel Oyuncakçılık Tic. Ltd. Şti. İçerenköy Mah., Umut Sokak No: 10 - 12, Quick Tower kat:2 içkapı no:15 Ataşehir 34752, İstanbul, Türkiye. Tel: 0216 570 75 00. Импортёр/Уполномоченная организация: ООО "МАТТЕЛ" Российская Федерация, 105120 Москва, 2-й Сыромятинский переулок,1; +7 495 287 79 39. Импортёр та дистрибутор Mattel в Україні ТОВ "ТойДіко Україна". Адреса: 04077 м. Київ, вул. Дніпровська 1, тел. (044) 251 49 20, (044) 451 75 06. Mattel, Inc., 636 Girard Avenue, East Aurora, NY 14052, U.S.A. Mattel Canada Inc., Mississauga, Ontario L5R 3W2. Consumer Services/Service à la clientèle: 1-800-524-8697 and/et 1-800-432-5437 for Fisher Price products/pour les produits Fisher Price. Importado y distribuido por Mattel de México, S.A. de C.V., Miguel de Cervantes Saavedra No. 193, Pisos 10 y 11, Col. Granada, Alcaldía Miguel Hidalgo, C.P. 11520, México, Ciudad de México. R.F.C. MME-920701-NB3. Tels.: 59-05-51-00 Ext. 5206 ó 01-800-463-59-89. Mattel Chile S.A., Pdtte. Riesco 5561, Of. 203-204 PS2, Las Condes, Santiago. Servicio al consumidor Venezuela: Tel.: 0-800-100-9123. Mattel Argentina, S.A., Av. Libertador 1000, Piso 11 - Oficinas 109 y 111, Vicente López - Prov. Buenos Aires. Tel.: 0800-666-3373. Mattel Colombia, S.A., Calle 123#7-07 P.5, Bogotá. Mattel Perú, S.A., Av. Juan de Arona # 151, Centro Empresarial Juan de Arona, Torre C, Piso 7, Oficina 704, San Isidro, Lima 27, Perú. RUC: 20425853865. Reg. Importador: 02350-12-JUE-DIGESA. Tel.: 0800-54744. E-mail Latinoamérica: servicio.clientes@mattel.com. Distribuido por: Mattel do Brasil Ltda. - CNPJ: 54.558.002/0001-20 - Av. Dr. Chucri Zaidan, 296 - 15º. Andar - 04583-110 - Vila Cordeiro - São Paulo - SP - Brasil. Serviço de Atendimento ao Consumidor: Contato: <https://faleconosco.mattel.com.br/Contato>. E-mail: sac.matteldobrazil@mattel.com.



K&N and the K&N logo are registered trademarks of K&N ENGINEERING, INC., and used under license.



The Japanese Nostalgic Car trademark is used under license from DCB Media, LLC.

TOYO TIRES

Toyo Tires trademark used under license. Marque Toyo Tires utilisée sous licence.



Mattel uses Motul trademark and copyright under license. Mattel utilise la marque Motul sous licence.



®D781,964, D797,203, D841,101, D977,027

Patent pending. Brevet en instance.



FR
DONNEZ
OU
RECYCLEZ



ASSOCIATION



MAGASIN



DÉCHÈTERIE

Adresses sur quefairedemesdechets.fr



©2026 Mattel. MATTEL, MATTEL BRICK SHOP, HOT WHEELS and associated trademarks and trade dress are owned by Mattel. ® and ™ designate U.S. trademarks of Mattel, except as noted. MATTEL, MATTEL BRICK SHOP, HOT WHEELS ainsi que les marques et designs y afférents appartiennent à Mattel. ® et ™ désignent des marques de Mattel aux États-Unis, sauf indication contraire.

Printed in China / Imprimé en Chine
AD-JK640-21A04

Inspirer les générations par le jeu

MATTEL

Empowering generations through play™

Supra

'94 TOYOTA SUPRA MKIV

