

FINAL ASSEMBLY



5+

SPEED RACER

HOT WHEELS



Contents

Keep these instructions for future reference as they contain important information.



Requires 4 "D" batteries (not included).

Refer to numbers on parts and contents page to help with assembly. Adult assembly required.

M4540-0920



SKY JUMP™

TRACK SET INSTRUCTIONS

SPEED RACER MOVIE: © Warner Bros. Entertainment Inc. SPEED RACER:™ Speed Racer Enterprises, Inc. (s08)

© 2007 Mattel, Inc. All Rights Reserved.

Mattel, Inc., 333 Continental Blvd., El Segundo, CA 90245 U.S.A. Consumer Relations 1 (800) 524-8697 service.mattel.com. Mattel Canada Inc., Mississauga, Ontario L5R 3W2. You may call us free at/ Composez sans frais le 1-800-524-8697. Mattel U.K. Ltd., Vanwall Business Park, Maidenhead SL6 4UB. Mattel Australia Pty., Ltd., Richmond, Victoria. 3121. Consumer Advisory Service - 1300 135 312. Mattel East Asia Ltd., Room 1106, South Tower, World Finance Centre, Harbour City, Tsimshatsui, HK, China. Diimport & Diedarkan Oleh: Mattel SEA Ptd Ltd (993532-P) Lot 13.5, 13th Floor, Menara Lien Hoe, Persiaran Tropicana Golf Country Resort, 47410 PJ. Tel:03-78803817, Fax:03-78803867.

BATTERY INSTALLATION / REPLACEMENT

Open battery cover. Insert 4 "D" size alkaline batteries in the orientation shown. Close cover. For best performance use only alkaline batteries. When booster is unable to propel vehicles through the set, replace the batteries.

BATTERY SAFETY INFORMATION

In exceptional circumstances batteries may leak fluids that can cause a chemical burn injury or ruin your product. To avoid battery leakage:

- Non-rechargeable batteries are not to be recharged.
- Rechargeable batteries are to be removed from the product before being charged (if designed to be removable).
- Rechargeable batteries are only to be charged under adult supervision (if designed to be removable).

- Do not mix alkaline, standard (carbon-zinc), or rechargeable (nickel-cadmium) batteries.
- Do not mix old and new batteries.
- Only batteries of the same or equivalent type as recommended are to be used.
- Batteries are to be inserted with the correct polarity.
- Exhausted batteries are to be removed from the product.
- The supply terminals are not to be short-circuited.
- Dispose of battery(ies) safely.
- Do not dispose of this product in a fire. The batteries inside may explode or leak.



Protect the environment by not disposing of this product with household waste [2002/96/EC]. Check with your local authority for recycling advice and facilities.

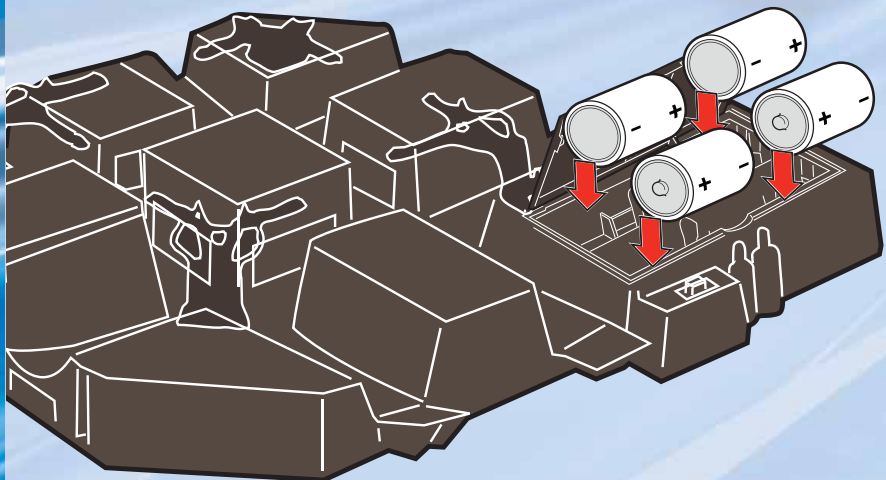

1 BASE ASSEMBLY

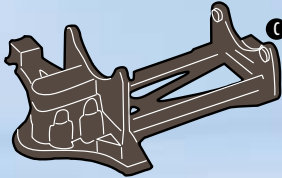
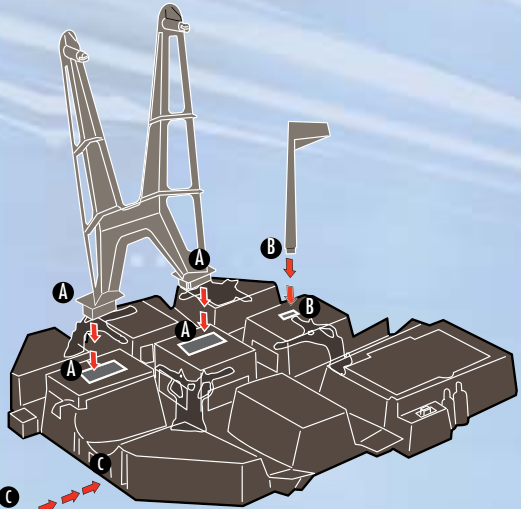
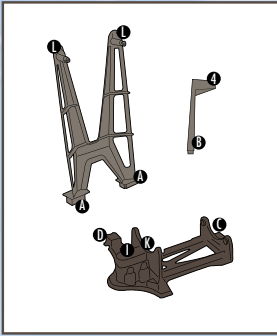

2

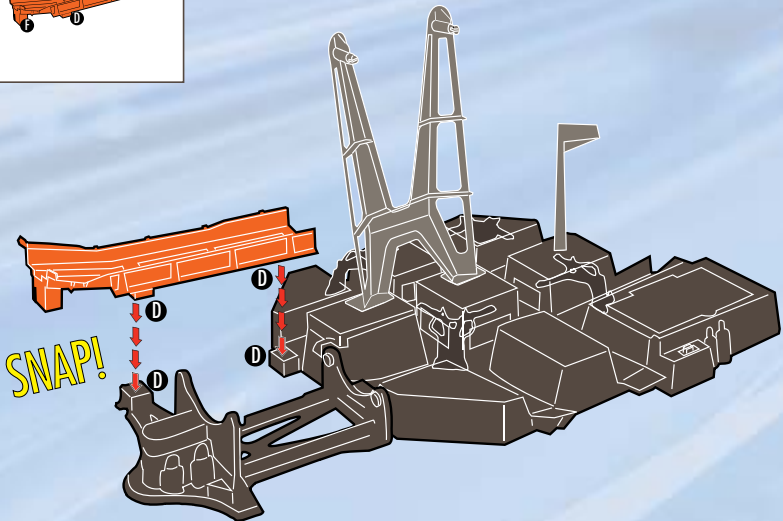
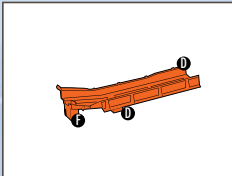

3A **PREPARE TOWER**

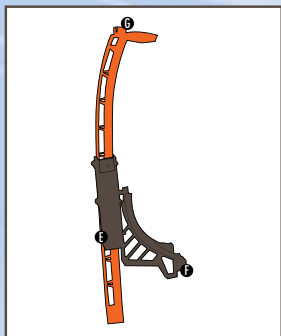

Pull base all the way down.

3B

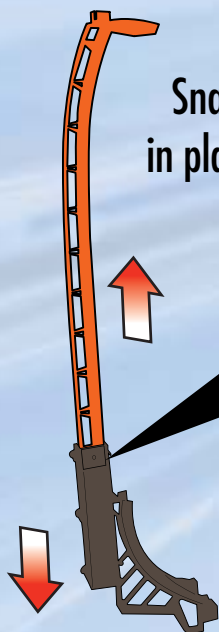

Snap in place.

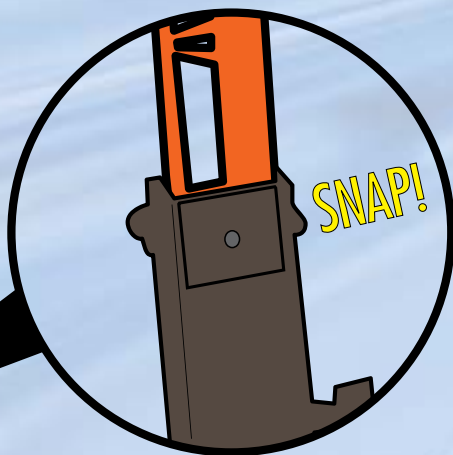

SNAP!

4

CONNECT TOWER TO BASE

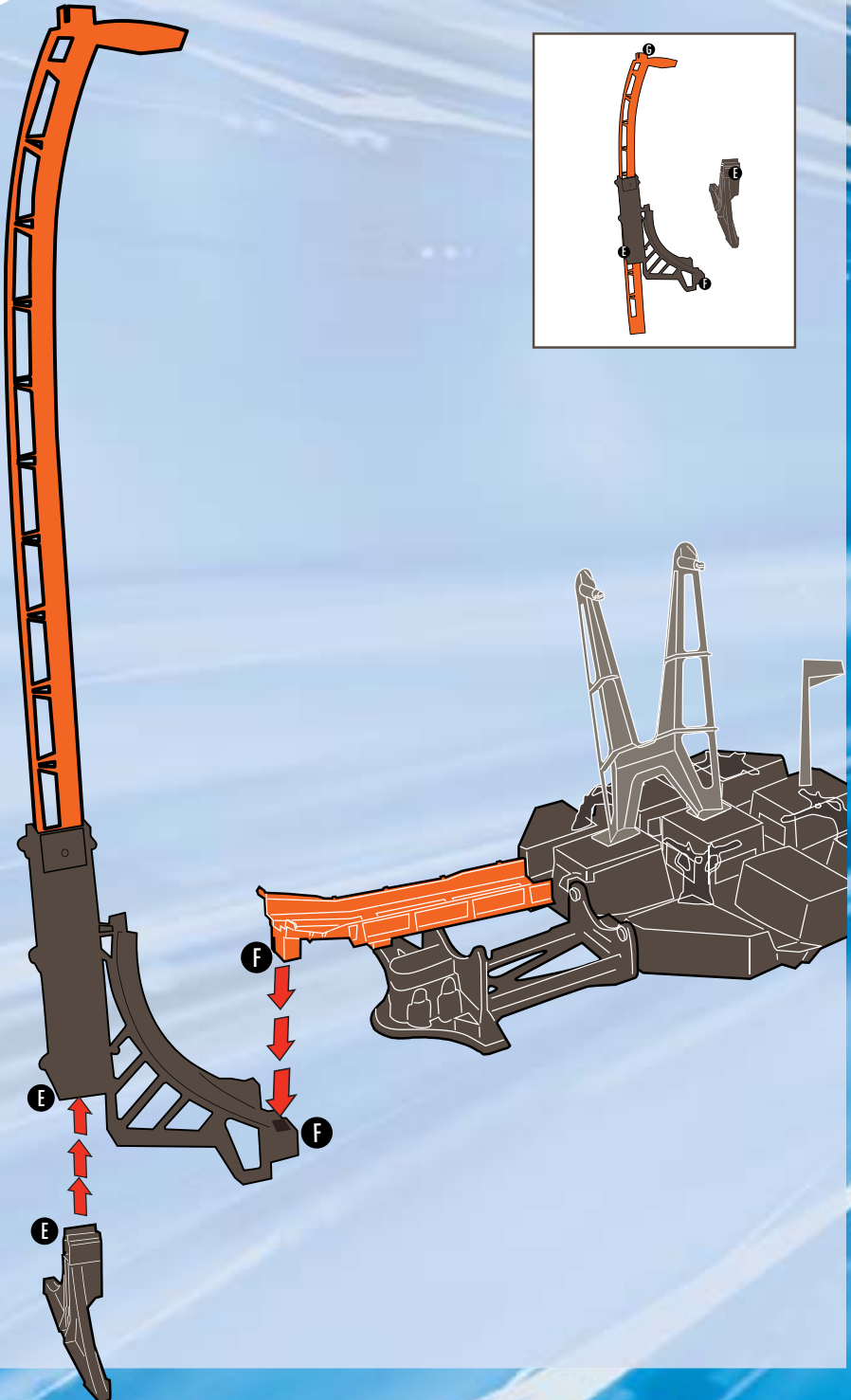

5

ADD CANOPY

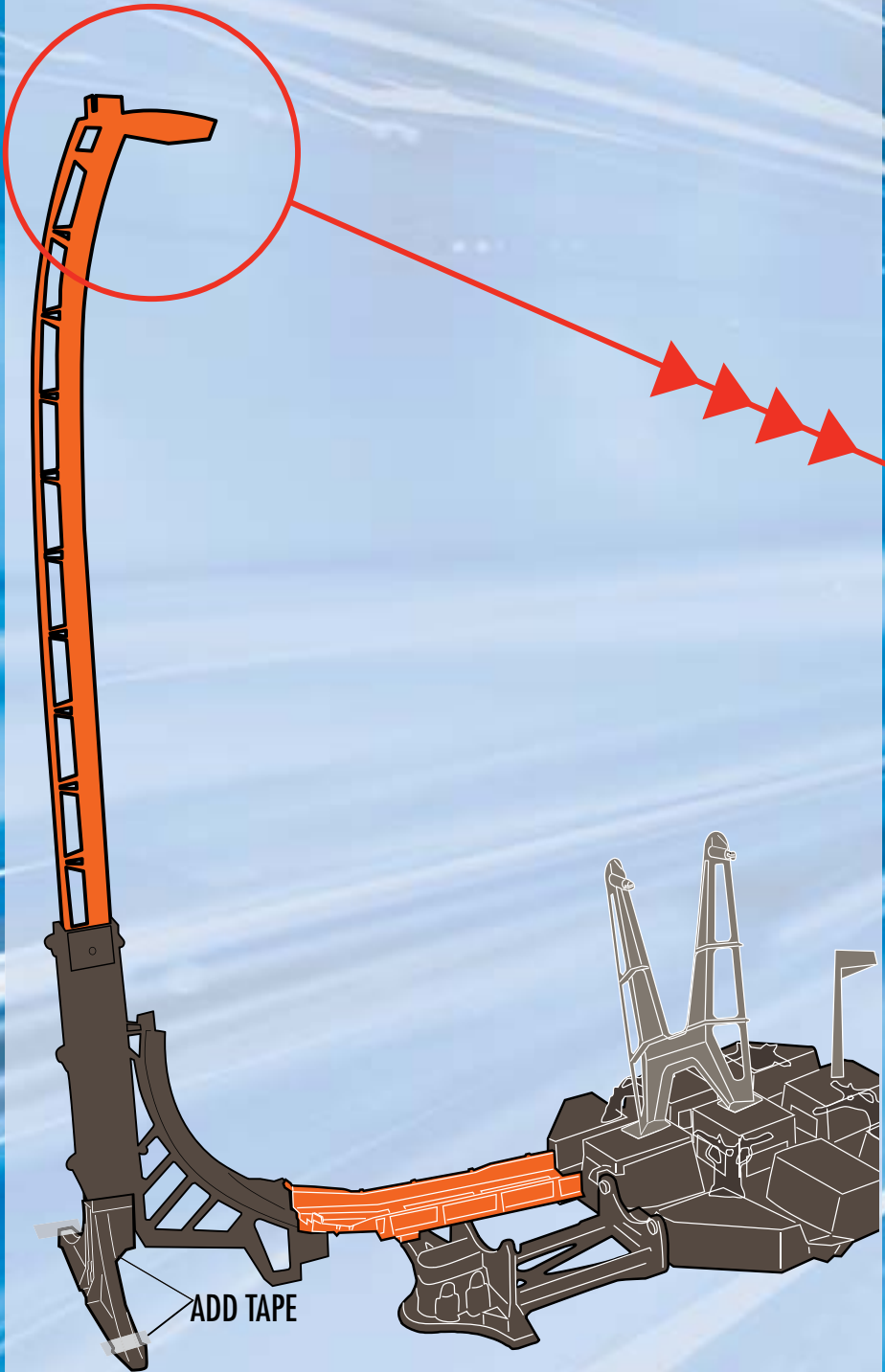

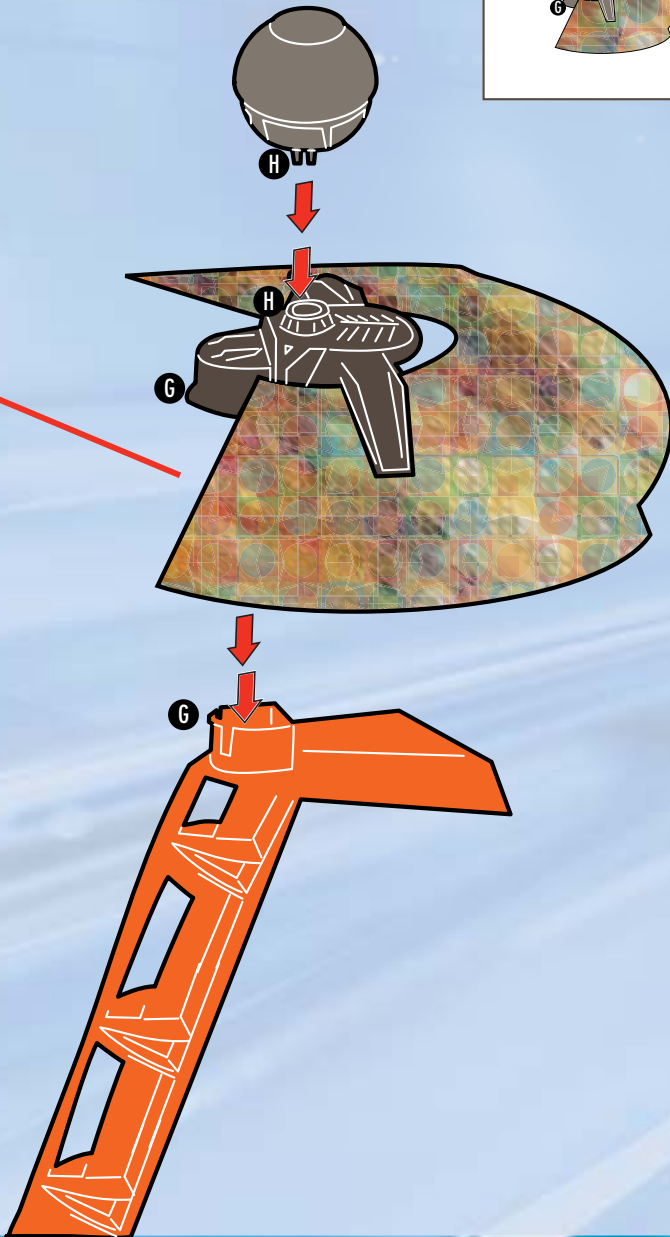
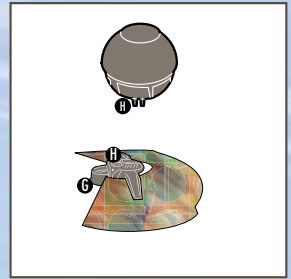

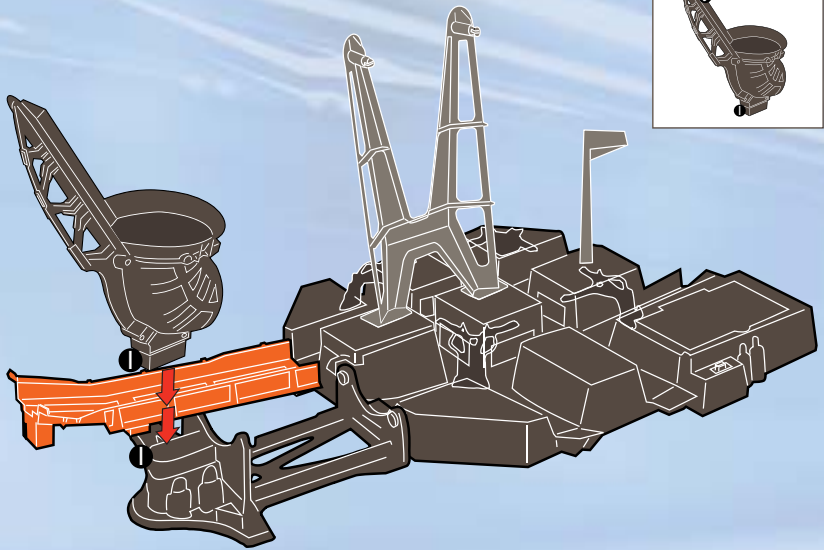
6**ADD FUNNEL****7**

Cone rests on inside of
funnel, shiny side in.

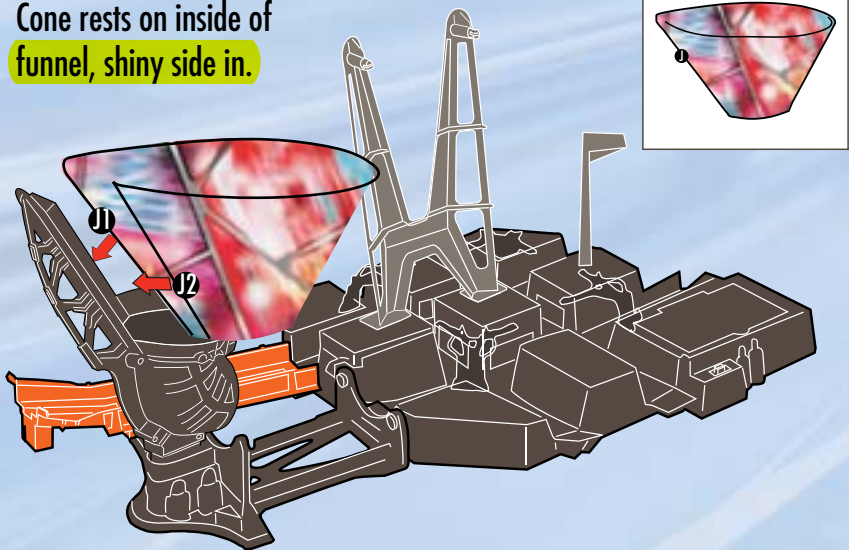

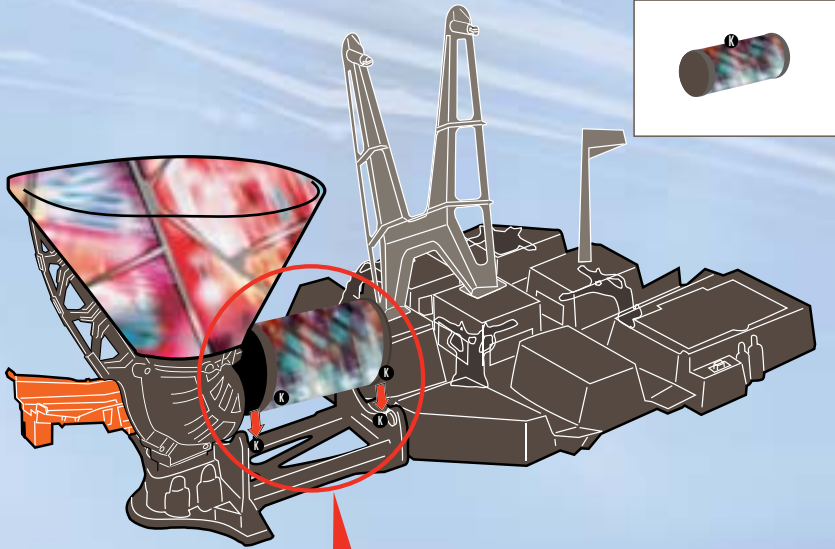

Set tunnel (K) on
top of rollers.

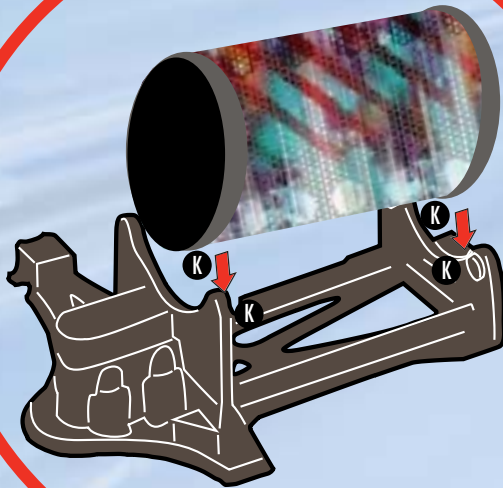

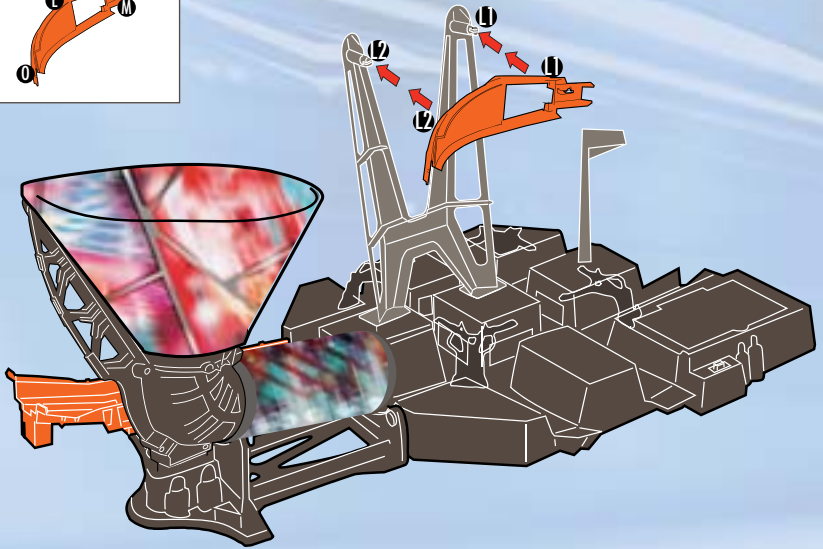
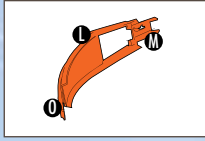
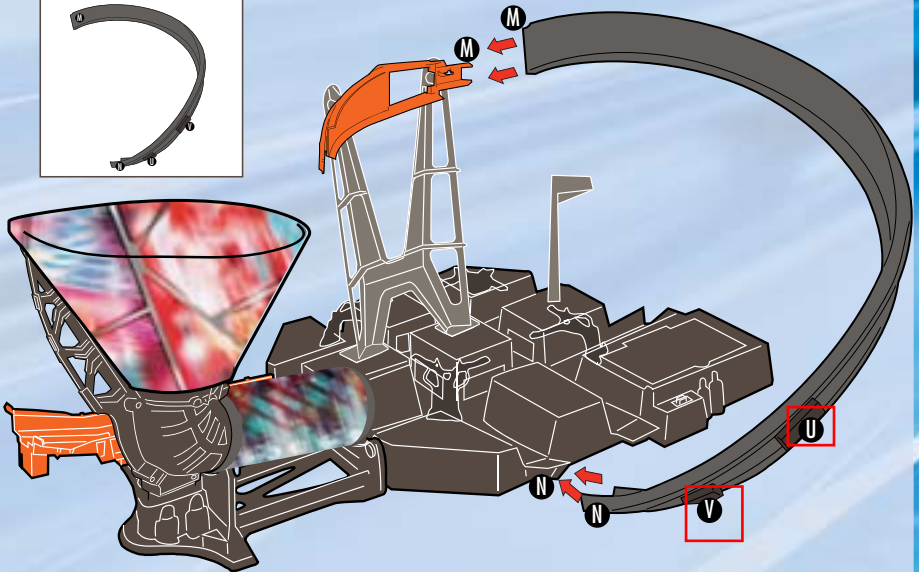
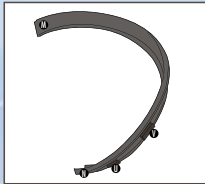
9**ADD CURVE CONNECTOR****10****RIGHT CURVE**

11

ADD CONNECTOR TO LEFT CURVE

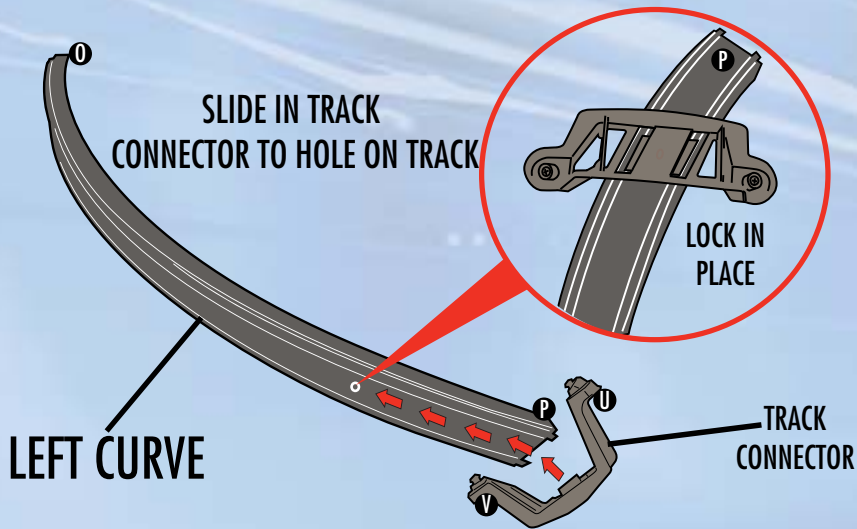

12

CONNECT LEFT CURVE

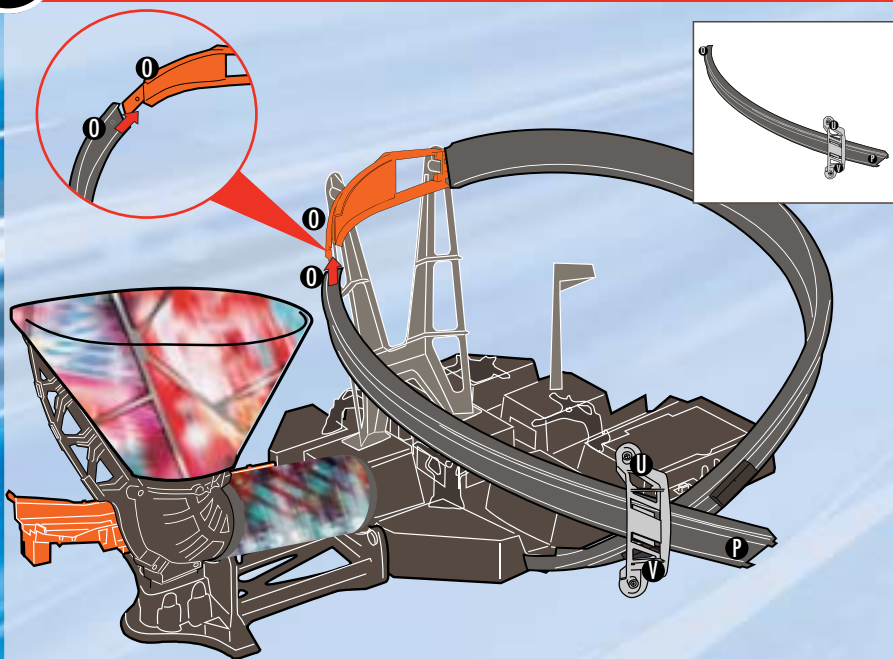

13

CONNECT LEFT CURVE TO BASE

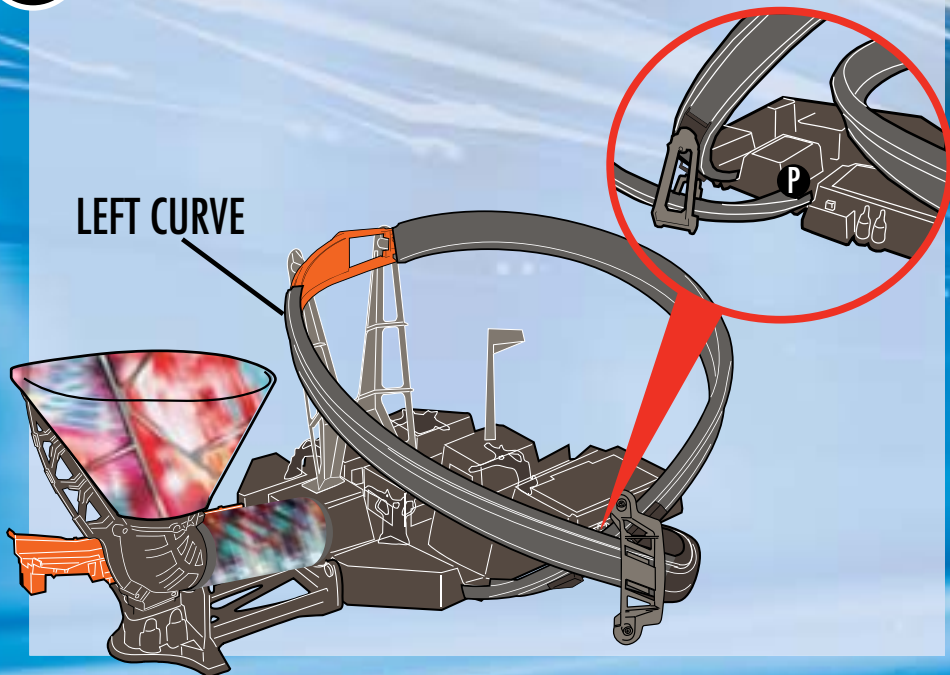

14

CONNECT TWO CURVES

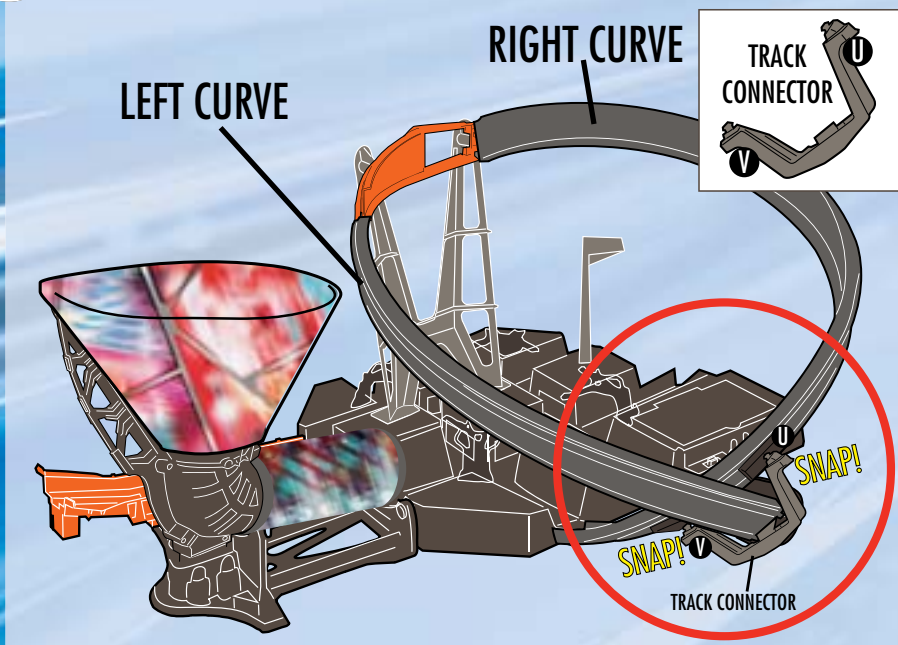

15

ADD REAR CURVE TRACKS

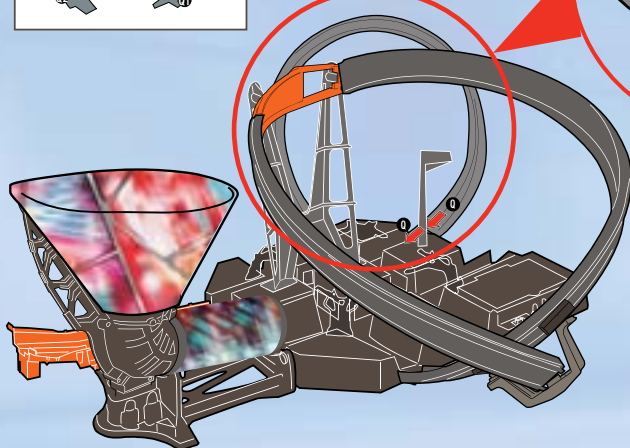
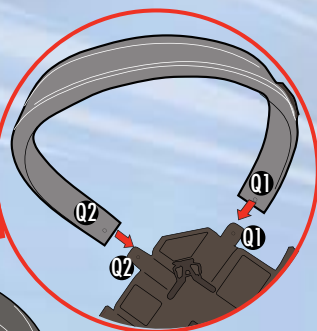
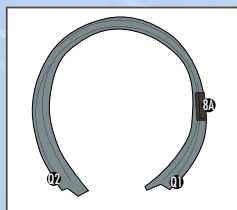

16

SNAP!

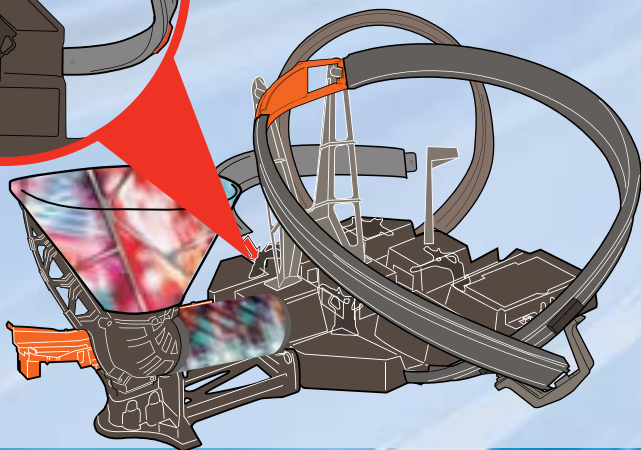
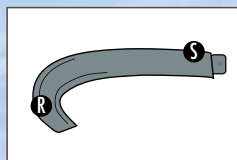
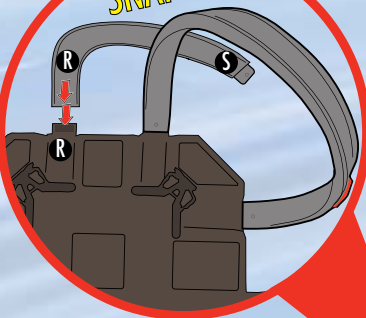

17 ADD STRAIGHT TRACK

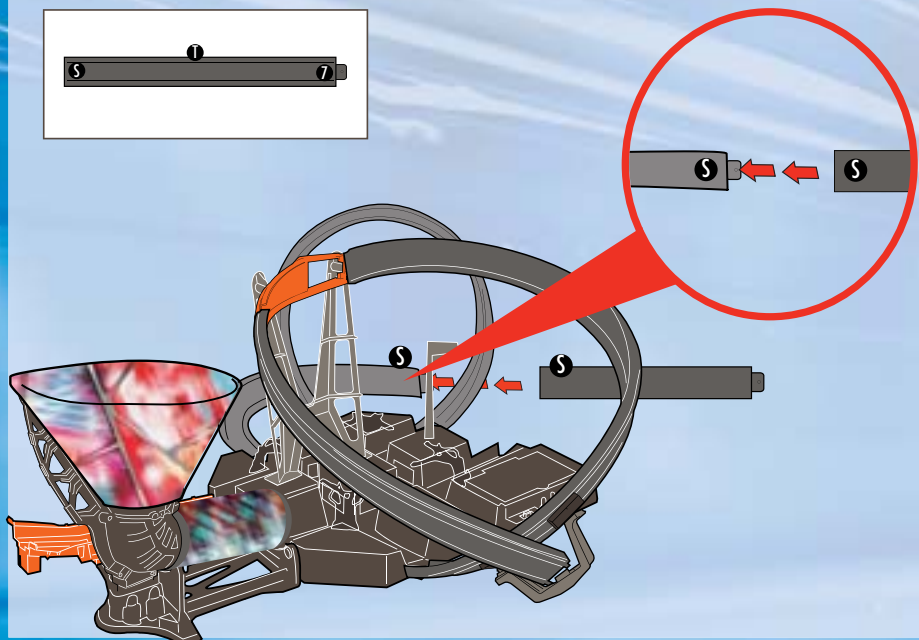

18 ADD BOTTOM SUPPORT

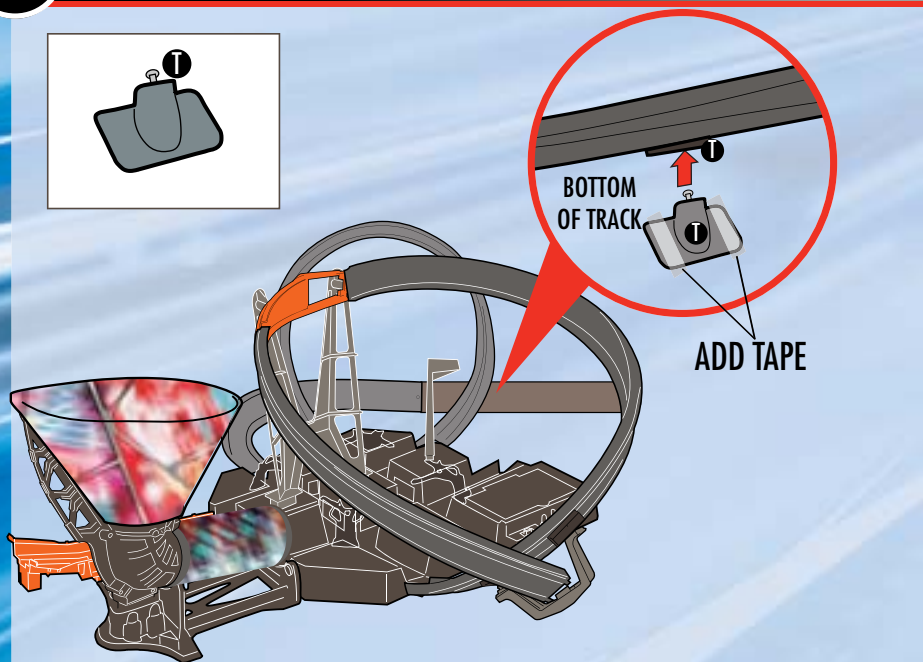

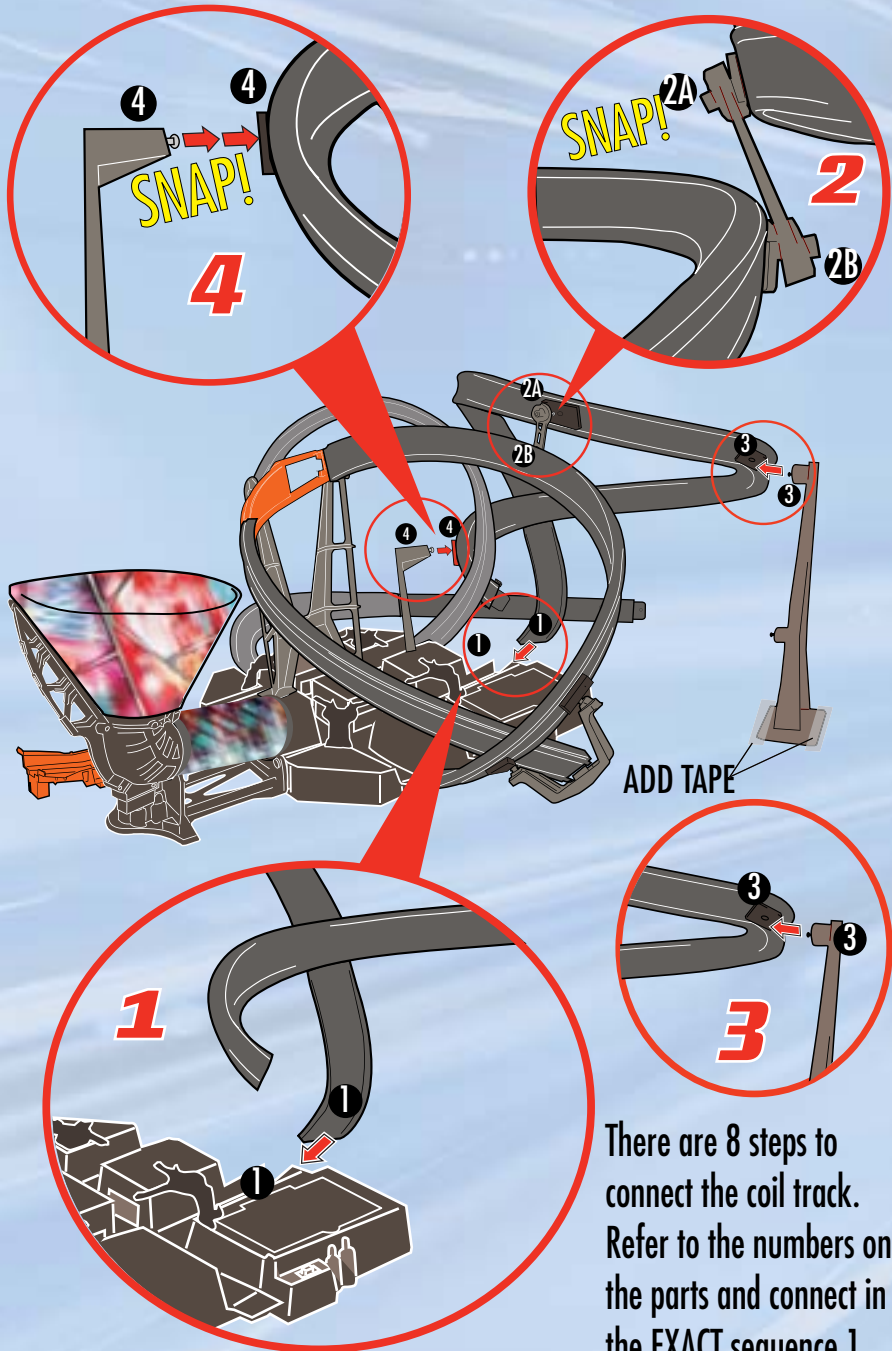

There are 8 steps to connect the coil track. Refer to the numbers on the parts and connect in the EXACT sequence 1 through 8 as shown.

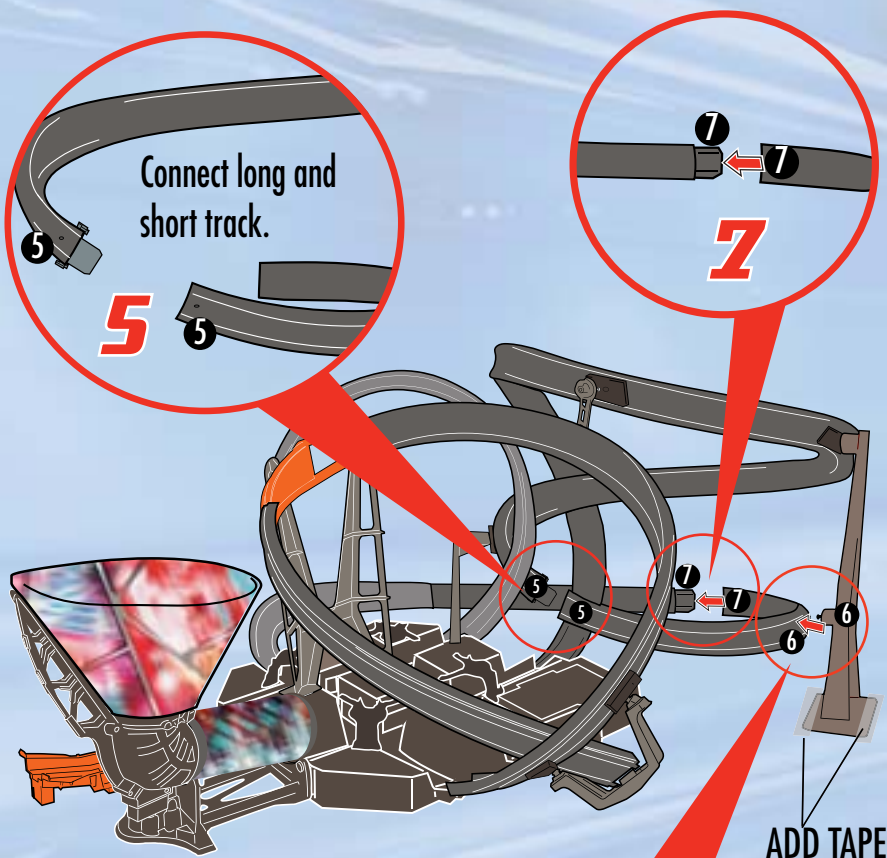

Continue referring to the numbers on the parts and keep connecting in the EXACT sequence 5 through 7 as shown here.

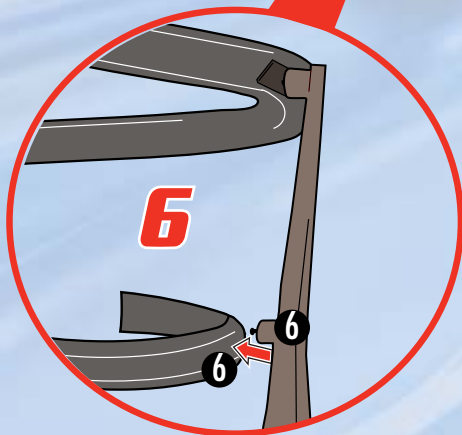

SNAP IN
BACK TRACK SUPPORT TO
TRACK AS SHOWN.

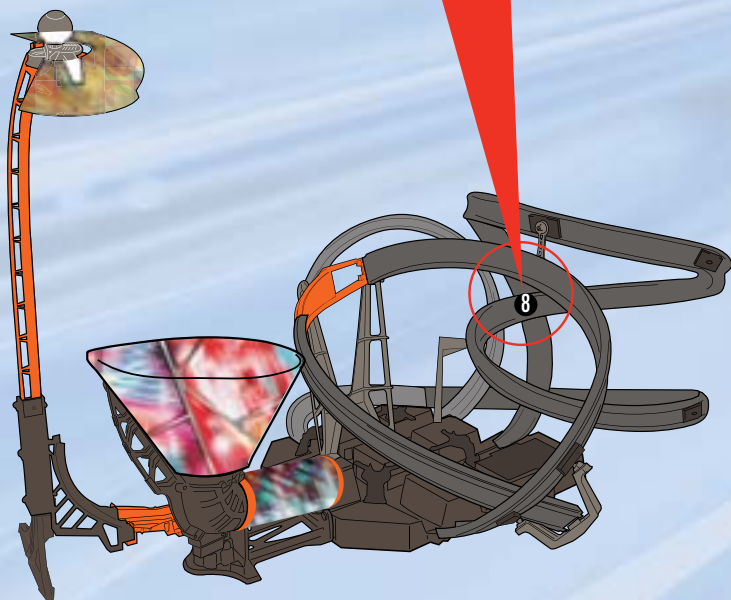
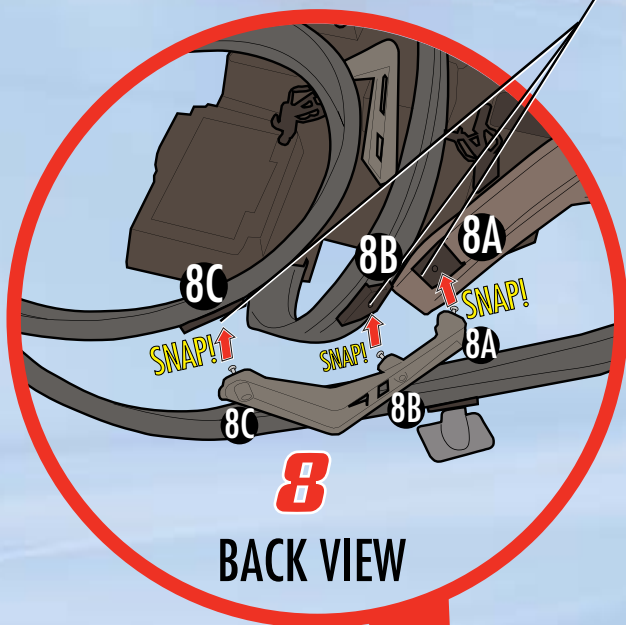

- Drop car(s) into the sky jump cone and slide through the tunnel. Your car is automatically uprighted and shot through the track.
- Watch as your car races through the track and completes a vertigo jump!
- Drop more cars into the sky jump cone...watch for crashes!

Move switch to **ON (I)** to start booster.

I = ON

O = OFF

Drop car(s)
into the
sky jump cone.

