

5+

# SPEED RACER

# HOT WHEELS

## TO PLAY:

Press and hold the car on the charger. Hold for approximately 10 seconds to get a good charge. Run the car until it needs recharging.

**CAUTION:** To prevent entanglement, keep hair away from wheels.

**CAUTION:** Vehicle contains a rechargeable cell. If fluid leaks, avoid contact with eyes and discard vehicle.

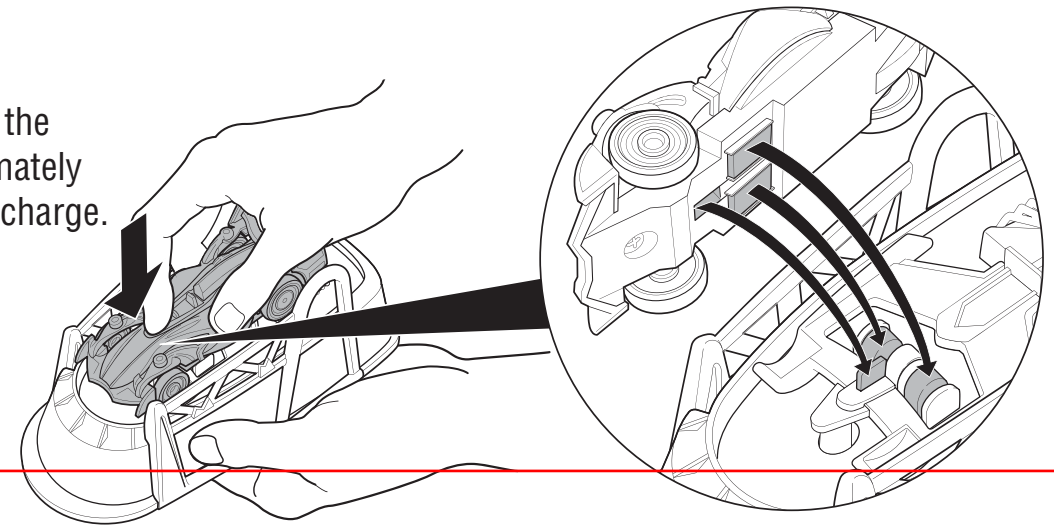

- This product is not recommended for use on loose dirt or wet surfaces.
- Do not immerse in water.
- Only use charger supplied with this toy.
- Do not use any other charging source.
- Do not use with Hot Wheels® Power Charger booster.
- Do not attempt to hold wheels while charging. Wheels must spin during charging period.
- During charging, the vehicle may cause radio or television interference. If so, move the vehicle away from the item being interfered with.

- Do not attempt to recharge a charged vehicle. Additional charging will not increase running time.
- Do not recharge the vehicle if it feels hot. Allow it to cool before recharging.
- Do not attempt to use or charge the vehicle if it shows signs of leakage or corrosion. If the vehicle and /or charger get wet, discontinue use until they are completely dry. Thoroughly wipe off all moisture and allow to air dry completely before use.

## CONTENTS:

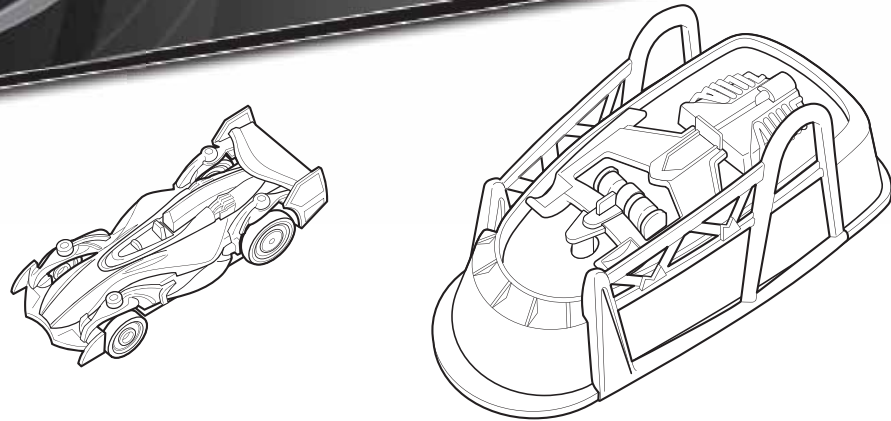

Keep these instructions for future reference as they contain important information. Requires 3 "AA" (LR6) alkaline batteries. Batteries included are for demonstration purposes.

## BATTERY INSTALLATION/REPLACEMENT

Remove battery cover with a Phillips head screwdriver (not included).

Remove batteries included for demonstration purposes and dispose of them safely. Insert 3 new "AA" (LR6) alkaline batteries in the orientation shown. Replace battery cover and tighten screw. For best performance use only alkaline batteries. Replace batteries if car does not charge or function properly.

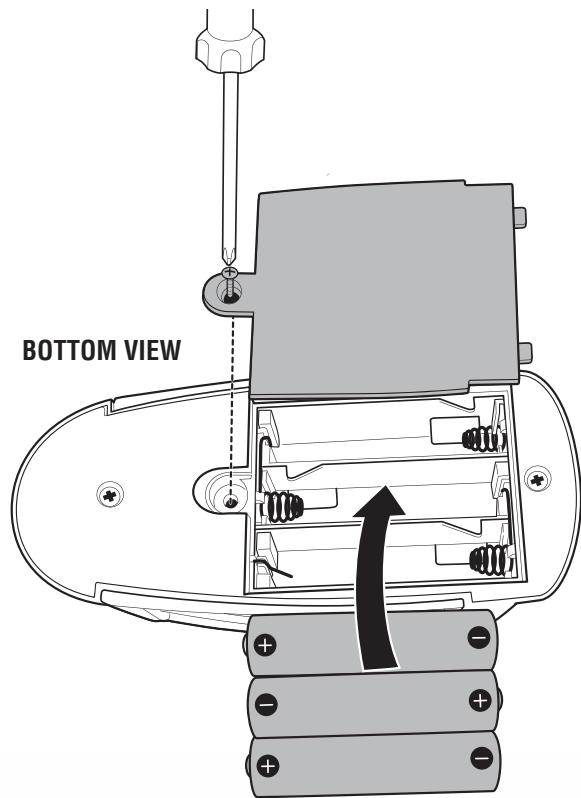

### BATTERY SAFETY INFORMATION

In exceptional circumstances batteries may leak fluids that can cause a chemical burn injury or ruin your product. To avoid battery leakage:

- Non-rechargeable batteries are not to be recharged.
- Rechargeable batteries are to be removed from the product before being charged (if designed to be removable).
- Rechargeable batteries are only to be charged under adult supervision (if designed to be removable).
- Do not mix alkaline, standard (carbon-zinc), or rechargeable (nickel-cadmium) batteries.
- Do not mix old and new batteries.
- Only batteries of the same or equivalent type as recommended are to be used.
- Batteries are to be inserted with the correct polarity.
- Exhausted batteries are to be removed from the product.
- The supply terminals are not to be short-circuited.
- Dispose of battery(ies) safely.
- Do not dispose of this product in a fire. The batteries inside may explode or leak.



Protect the environment by not disposing of this product with household waste (2002/96/EC). Check your local authority for recycling advice and facilities.

This equipment has been tested and found to comply with the limits for a Class B digital device, pursuant to part 15 of the FCC rules. These limits are designed to provide reasonable protection against harmful interference in a residential installation. This equipment generates, uses and can radiate radio frequency energy and, if not installed and used in accordance with the instructions, may cause harmful interference to radio communications. However, there is no guarantee that interference will not occur in a particular installation. If this equipment does cause harmful interference to radio or television reception, which can be determined by turning the equipment off and on, the user is encouraged to try to correct the interference by one or more of the following measures:

- Reorient or relocate the receiving antenna.
- Increase the separation between the equipment and receiver.
- Connect the equipment into an outlet on a circuit different from that to which the receiver is connected.
- Consult the dealer or an experienced radio/TV technician for help.

Note: Changes or modifications not expressly approved by the manufacturer responsible for compliance could void the user's authority to operate the equipment.

SPEED RACER MOVIE: © Warner Bros. Entertainment Inc. SPEED RACER: ™ Speed Racer Enterprises, Inc. (s08)

© 2007 Mattel, Inc. All Rights Reserved.

M5960-0920  
ASST. M4533



Mattel, Inc. 333 Continental Blvd., El Segundo, CA 90245 U.S.A. Consumer Relations 1 (800) 524-8697 service.mattel.com. • Mattel Canada Inc., Mississauga, Ontario L5R 3W2. You may call us free at/ Composez sans frais le 1-800-524-8697. • Mattel U.K. Ltd., Vanwall Business Park, Maidenhead SL6 4UB. • Mattel Australia Pty., Ltd., Richmond, Victoria. 3121. Consumer Advisory Service - 1300 135 312. • Mattel East Asia Ltd., Room 1106, South Tower, World Finance Centre, Harbour City, Tsimshatsui, HK, China. • Diimport & Diedarkan Oleh: Mattel SEA Ptd Ltd. (993532-P) Lot 13.5, 13th Floor, Menara Lien Hoe, Persiaran Tropicana Golf Country Resort, 47410 PJ. Tel:03-78803817, Fax:03-78803867.

# INSTRUCTIONS

5+

# SPEED RACER

# HOT WHEELS

## CONTENTS:

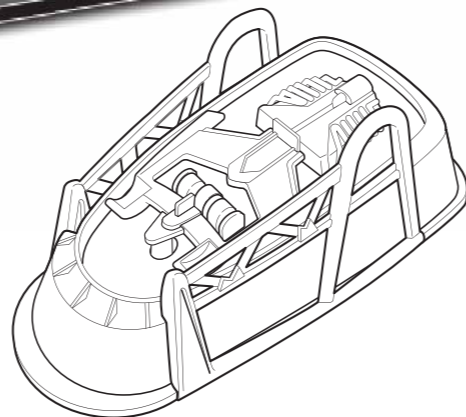
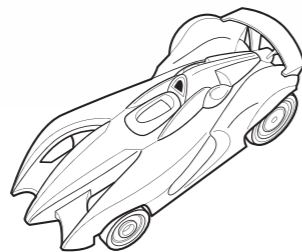

Keep these instructions for future reference as they contain important information.  
Requires 3 "AA" (LR6) alkaline batteries. Batteries included are for demonstration purposes.

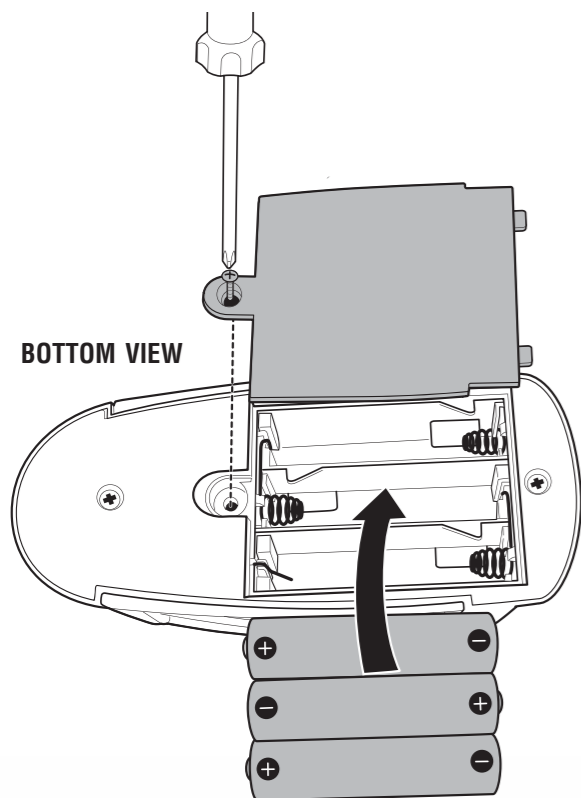

## BATTERY INSTALLATION/REPLACEMENT

Remove battery cover with a Phillips head screwdriver (not included).

Remove batteries included for demonstration purposes and dispose of them safely. Insert 3 new "AA" (LR6) alkaline batteries in the orientation shown. Replace battery cover and tighten screw. For best performance use only alkaline batteries. Replace batteries if car does not charge or function properly.

# INSTRUCTIONS

## TO PLAY:

Press and hold the car on the charger. Hold for approximately 10 seconds to get a good charge.  
Run the car until it needs recharging.

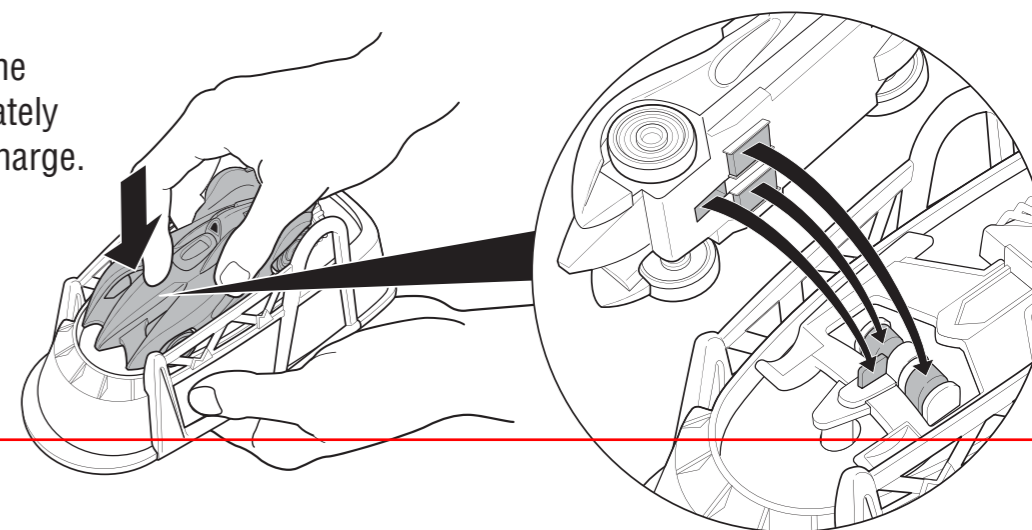

**CAUTION:** To prevent entanglement, keep hair away from wheels.

**CAUTION:** Vehicle contains a rechargeable cell. If fluid leaks, avoid contact with eyes and discard vehicle.

- This product is not recommended for use on loose dirt or wet surfaces.
- Do not immerse in water.
- Only use charger supplied with this toy.
- Do not use any other charging source.
- Do not use with Hot Wheels® Power Charger booster.
- Do not attempt to hold wheels while charging. Wheels must spin during charging period.
- During charging, the vehicle may cause radio or television interference. If so, move the vehicle away from the item being interfered with.

- Do not attempt to recharge a charged vehicle. Additional charging will not increase running time.
- Do not recharge the vehicle if it feels hot. Allow it to cool before recharging.
- Do not attempt to use or charge the vehicle if it shows signs of leakage or corrosion. If the vehicle and /or charger get wet, discontinue use until they are completely dry. Thoroughly wipe off all moisture and allow to air dry completely before use.

### BATTERY SAFETY INFORMATION

In exceptional circumstances batteries may leak fluids that can cause a chemical burn injury or ruin your product. To avoid battery leakage:

- Non-rechargeable batteries are not to be recharged.
- Rechargeable batteries are to be removed from the product before being charged (if designed to be removable).
- Rechargeable batteries are only to be charged under adult supervision (if designed to be removable).
- Do not mix alkaline, standard (carbon-zinc), or rechargeable (nickel-cadmium) batteries.
- Do not mix old and new batteries.
- Only batteries of the same or equivalent type as recommended are to be used.
- Batteries are to be inserted with the correct polarity.
- Exhausted batteries are to be removed from the product.
- The supply terminals are not to be short-circuited.
- Dispose of battery(ies) safely.
- Do not dispose of this product in a fire. The batteries inside may explode or leak.



Protect the environment by not disposing of this product with household waste (2002/96/EC). Check your local authority for recycling advice and facilities.

This equipment has been tested and found to comply with the limits for a Class B digital device, pursuant to part 15 of the FCC rules. These limits are designed to provide reasonable protection against harmful interference in a residential installation. This equipment generates, uses and can radiate radio frequency energy and, if not installed and used in accordance with the instructions, may cause harmful interference to radio communications. However, there is no guarantee that interference will not occur in a particular installation. If this equipment does cause harmful interference to radio or television reception, which can be determined by turning the equipment off and on, the user is encouraged to try to correct the interference by one or more of the following measures:

- Reorient or relocate the receiving antenna.
- Increase the separation between the equipment and receiver.
- Connect the equipment into an outlet on a circuit different from that to which the receiver is connected.
- Consult the dealer or an experienced radio/TV technician for help.

Note: Changes or modifications not expressly approved by the manufacturer responsible for compliance could void the user's authority to operate the equipment.

SPEED RACER MOVIE: © Warner Bros. Entertainment Inc. SPEED RACER:™ Speed Racer Enterprises, Inc. (s08)

© 2007 Mattel, Inc. All Rights Reserved.

M5961-0920  
ASST. M4533



Mattel, Inc. 333 Continental Blvd., El Segundo, CA 90245 U.S.A. Consumer Relations 1 (800) 524-8697 service.mattel.com. • Mattel Canada Inc., Mississauga, Ontario L5R 3W2. You may call us free at/ Composez sans frais le 1-800-524-8697. • Mattel U.K. Ltd., Vanwall Business Park, Maidenhead SL6 4UB. • Mattel Australia Pty., Ltd., Richmond, Victoria. 3121. Consumer Advisory Service - 1300 135 312. • Mattel East Asia Ltd., Room 1106, South Tower, World Finance Centre, Harbour City, Tsimshatsui, HK, China. • Diimport & Diedarkan Oleh: Mattel SEA Ptd Ltd. (993532-P) Lot 13.5, 13th Floor, Menara Lien Hoe, Persiaran Tropicana Golf Country Resort, 47410 PJ. Tel:03-78803817, Fax:03-78803867.

5+

# SPEED RACER

# Hot Wheels

## CONTENTS:

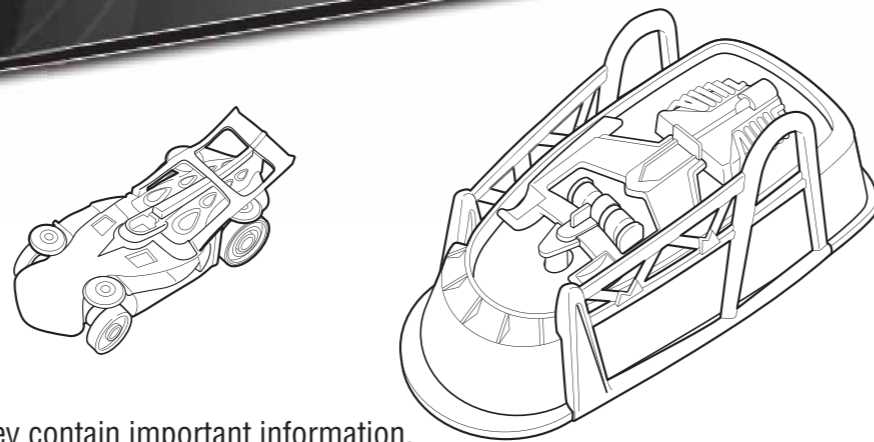

Keep these instructions for future reference as they contain important information.  
Requires 3 "AA" (LR6) alkaline batteries. Batteries included are for demonstration purposes.

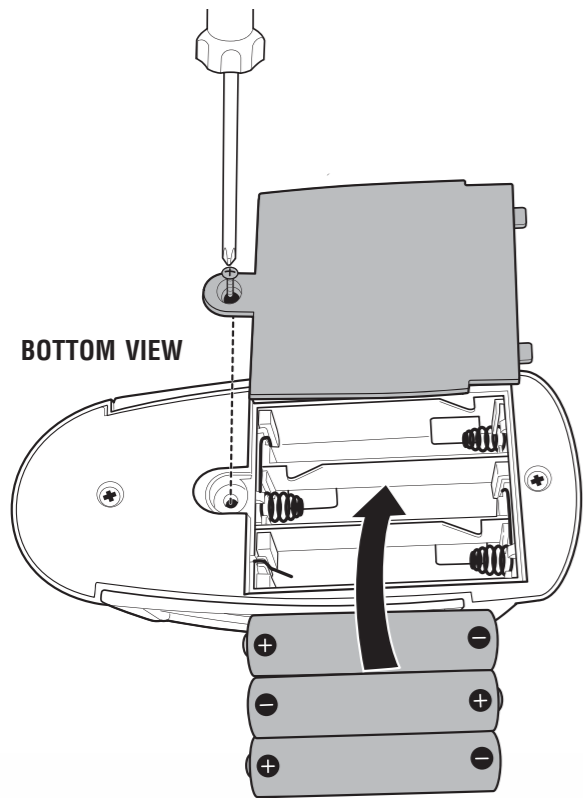

## BATTERY INSTALLATION/REPLACEMENT

Remove battery cover with a Phillips head screwdriver (not included).

Remove batteries included for demonstration purposes and dispose of them safely. Insert 3 new "AA" (LR6) alkaline batteries in the orientation shown. Replace battery cover and tighten screw. For best performance use only alkaline batteries. Replace batteries if car does not charge or function properly.

# INSTRUCTIONS

## TO PLAY:

Press and hold the car on the charger. Hold for approximately 10 seconds to get a good charge.  
Run the car until it needs recharging.

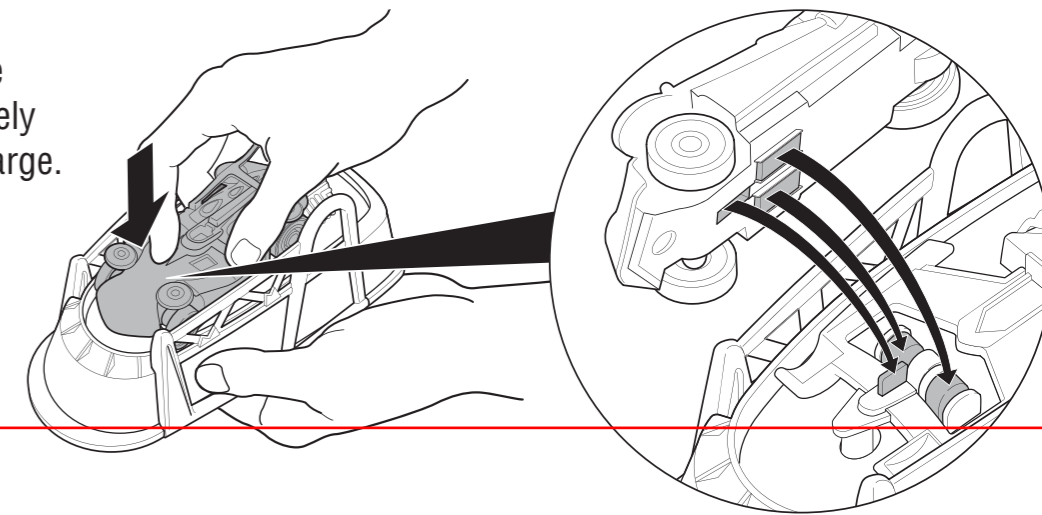

**CAUTION:** To prevent entanglement, keep hair away from wheels.

**CAUTION:** Vehicle contains a rechargeable cell. If fluid leaks, avoid contact with eyes and discard vehicle.

- This product is not recommended for use on loose dirt or wet surfaces.
- Do not immerse in water.
- Only use charger supplied with this toy.
- Do not use any other charging source.
- Do not use with Hot Wheels® Power Charger booster.
- Do not attempt to hold wheels while charging. Wheels must spin during charging period.
- During charging, the vehicle may cause radio or television interference. If so, move the vehicle away from the item being interfered with.

- Do not attempt to recharge a charged vehicle. Additional charging will not increase running time.
- Do not recharge the vehicle if it feels hot. Allow it to cool before recharging.
- Do not attempt to use or charge the vehicle if it shows signs of leakage or corrosion. If the vehicle and /or charger get wet, discontinue use until they are completely dry. Thoroughly wipe off all moisture and allow to air dry completely before use.

### BATTERY SAFETY INFORMATION

In exceptional circumstances batteries may leak fluids that can cause a chemical burn injury or ruin your product. To avoid battery leakage:

- Non-rechargeable batteries are not to be recharged.
- Rechargeable batteries are to be removed from the product before being charged (if designed to be removable).
- Rechargeable batteries are only to be charged under adult supervision (if designed to be removable).
- Do not mix alkaline, standard (carbon-zinc), or rechargeable (nickel-cadmium) batteries.
- Do not mix old and new batteries.
- Only batteries of the same or equivalent type as recommended are to be used.
- Batteries are to be inserted with the correct polarity.
- Exhausted batteries are to be removed from the product.
- The supply terminals are not to be short-circuited.
- Dispose of battery(ies) safely.
- Do not dispose of this product in a fire. The batteries inside may explode or leak.

Protect the environment by not disposing of this product with household waste (2002/96/EC). Check your local authority for recycling advice and facilities.

This equipment has been tested and found to comply with the limits for a Class B digital device, pursuant to part 15 of the FCC rules. These limits are designed to provide reasonable protection against harmful interference in a residential installation. This equipment generates, uses and can radiate radio frequency energy and, if not installed and used in accordance with the instructions, may cause harmful interference to radio communications. However, there is no guarantee that interference will not occur in a particular installation. If this equipment does cause harmful interference to radio or television reception, which can be determined by turning the equipment off and on, the user is encouraged to try to correct the interference by one or more of the following measures:

- Reorient or relocate the receiving antenna.
- Increase the separation between the equipment and receiver.
- Connect the equipment into an outlet on a circuit different from that to which the receiver is connected.
- Consult the dealer or an experienced radio/TV technician for help.

Note: Changes or modifications not expressly approved by the manufacturer responsible for compliance could void the user's authority to operate the equipment.

SPEED RACER MOVIE: © Warner Bros. Entertainment Inc. SPEED RACER:™ Speed Racer Enterprises, Inc. (s08)

© 2007 Mattel, Inc. All Rights Reserved.

M5963-0920  
ASST. M4533



Mattel, Inc. 333 Continental Blvd., El Segundo, CA 90245 U.S.A. Consumer Relations 1 (800) 524-8697 service.mattel.com. • Mattel Canada Inc., Mississauga, Ontario L5R 3W2. You may call us free at/ Composez sans frais le 1-800-524-8697. • Mattel U.K. Ltd., Vanwall Business Park, Maidenhead SL6 4UB. • Mattel Australia Pty., Ltd., Richmond, Victoria. 3121. Consumer Advisory Service - 1300 135 312. • Mattel East Asia Ltd., Room 1106, South Tower, World Finance Centre, Harbour City, Tsimshatsui, HK, China. • Diimport & Diedarkan Oleh: Mattel SEA Ptd Ltd.(993532-P) Lot 13.5, 13th Floor, Menara Lien Hoe, Persiaran Tropicana Golf Country Resort, 47410 PJ. Tel:03-78803817, Fax:03-78803867.

5+



## CONTENTS:

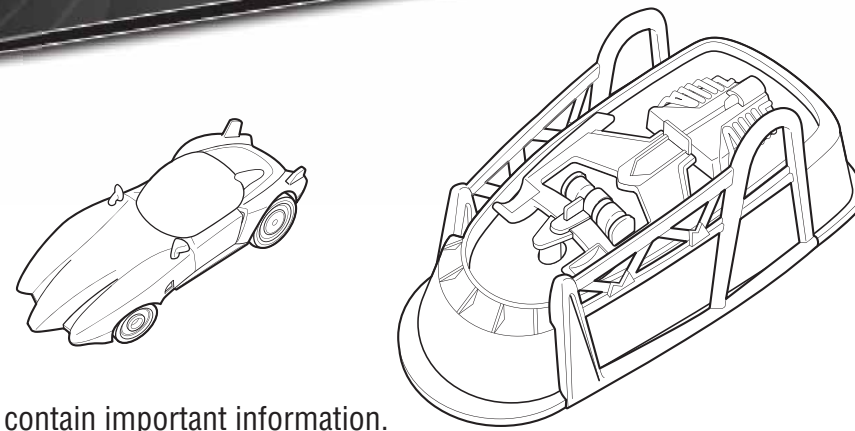

Keep these instructions for future reference as they contain important information.  
Requires 3 "AA" (LR6) alkaline batteries. Batteries included are for demonstration purposes.

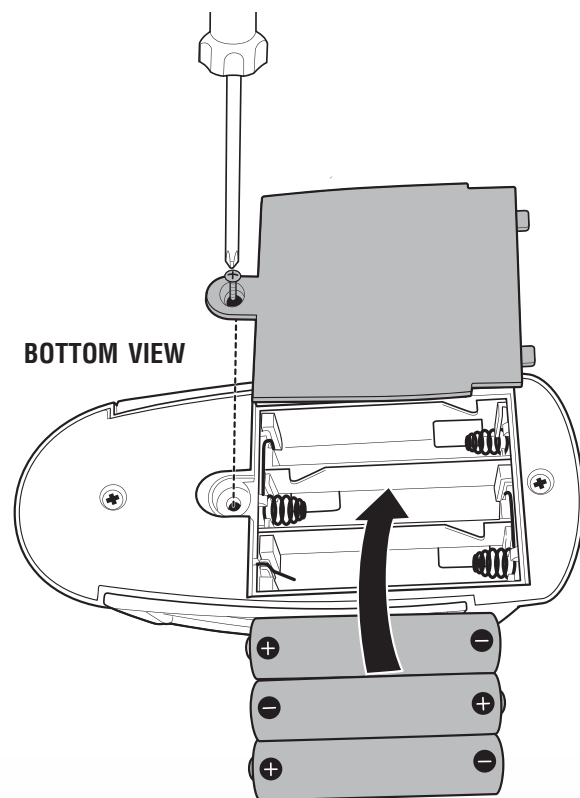

## BATTERY INSTALLATION/REPLACEMENT

Remove battery cover with a Phillips head screwdriver (not included).

Remove batteries included for demonstration purposes and dispose of them safely. Insert 3 new "AA" (LR6) alkaline batteries in the orientation shown. Replace battery cover and tighten screw. For best performance use only alkaline batteries. Replace batteries if car does not charge or function properly.

## TO PLAY:

Press and hold the car on the charger. Hold for approximately 10 seconds to get a good charge.  
Run the car until it needs recharging.

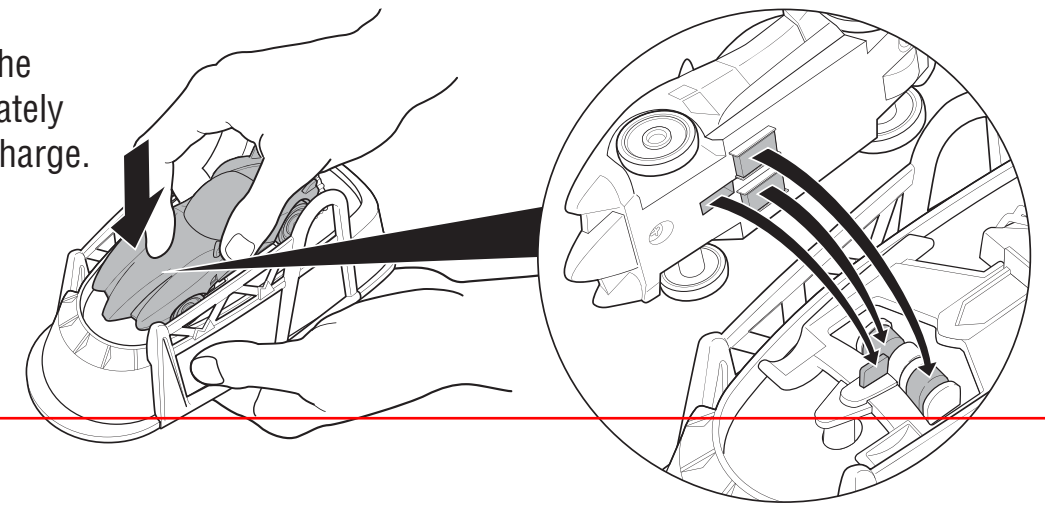

**CAUTION:** To prevent entanglement, keep hair away from wheels.

**CAUTION:** Vehicle contains a rechargeable cell. If fluid leaks, avoid contact with eyes and discard vehicle.

- This product is not recommended for use on loose dirt or wet surfaces.
- Do not immerse in water.
- Only use charger supplied with this toy.
- Do not use any other charging source.
- Do not use with Hot Wheels® Power Charger booster.
- Do not attempt to hold wheels while charging. Wheels must spin during charging period.
- During charging, the vehicle may cause radio or television interference. If so, move the vehicle away from the item being interfered with.

- Do not attempt to recharge a charged vehicle. Additional charging will not increase running time.
- Do not recharge the vehicle if it feels hot. Allow it to cool before recharging.
- Do not attempt to use or charge the vehicle if it shows signs of leakage or corrosion. If the vehicle and /or charger get wet, discontinue use until they are completely dry. Thoroughly wipe off all moisture and allow to air dry completely before use.

### BATTERY SAFETY INFORMATION

In exceptional circumstances batteries may leak fluids that can cause a chemical burn injury or ruin your product. To avoid battery leakage:

- Non-rechargeable batteries are not to be recharged.
- Rechargeable batteries are to be removed from the product before being charged (if designed to be removable).
- Rechargeable batteries are only to be charged under adult supervision (if designed to be removable).
- Do not mix alkaline, standard (carbon-zinc), or rechargeable (nickel-cadmium) batteries.
- Do not mix old and new batteries.
- Only batteries of the same or equivalent type as recommended are to be used.
- Batteries are to be inserted with the correct polarity.
- Exhausted batteries are to be removed from the product.
- The supply terminals are not to be short-circuited.
- Dispose of battery(ies) safely.
- Do not dispose of this product in a fire. The batteries inside may explode or leak.



Protect the environment by not disposing of this product with household waste (2002/96/EC). Check your local authority for recycling advice and facilities.

This equipment has been tested and found to comply with the limits for a Class B digital device, pursuant to part 15 of the FCC rules. These limits are designed to provide reasonable protection against harmful interference in a residential installation. This equipment generates, uses and can radiate radio frequency energy and, if not installed and used in accordance with the instructions, may cause harmful interference to radio communications. However, there is no guarantee that interference will not occur in a particular installation. If this equipment does cause harmful interference to radio or television reception, which can be determined by turning the equipment off and on, the user is encouraged to try to correct the interference by one or more of the following measures:

- Reorient or relocate the receiving antenna.
- Increase the separation between the equipment and receiver.
- Connect the equipment into an outlet on a circuit different from that to which the receiver is connected.
- Consult the dealer or an experienced radio/TV technician for help.

Note: Changes or modifications not expressly approved by the manufacturer responsible for compliance could void the user's authority to operate the equipment.

SPEED RACER MOVIE: © Warner Bros. Entertainment Inc. SPEED RACER:™ Speed Racer Enterprises, Inc. (s08)

© 2007 Mattel, Inc. All Rights Reserved.

M9479-0920  
ASST. M4533



Mattel, Inc. 333 Continental Blvd., El Segundo, CA 90245 U.S.A. Consumer Relations 1 (800) 524-8697 service.mattel.com. • Mattel Canada Inc., Mississauga, Ontario L5R 3W2. You may call us free at/ Composez sans frais le 1-800-524-8697. • Mattel U.K. Ltd., Vanwall Business Park, Maidenhead SL6 4UB. • Mattel Australia Pty., Ltd., Richmond, Victoria. 3121. Consumer Advisory Service - 1300 135 312. • Mattel East Asia Ltd., Room 1106, South Tower, World Finance Centre, Harbour City, Tsimshatsui, HK, China. • Diimport & Diedarkan Oleh: Mattel SEA Ptd Ltd.(993532-P) Lot 13.5, 13th Floor, Menara Lien Hoe, Persiaran Tropicana Golf Country Resort, 47410 PJ. Tel:03-78803817, Fax:03-78803867.

# INSTRUCTIONS