

4.

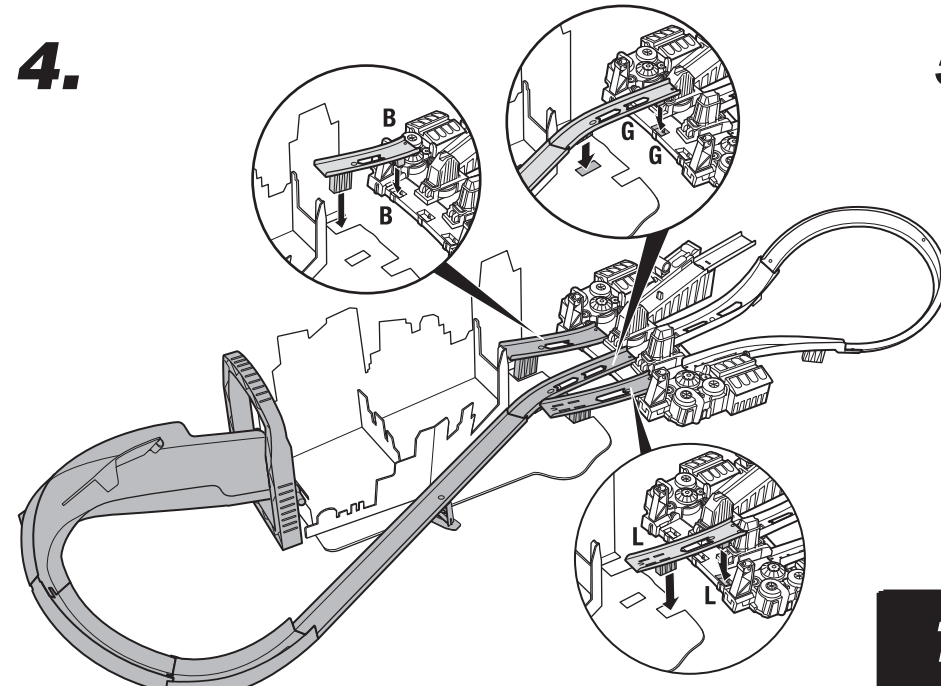

5.

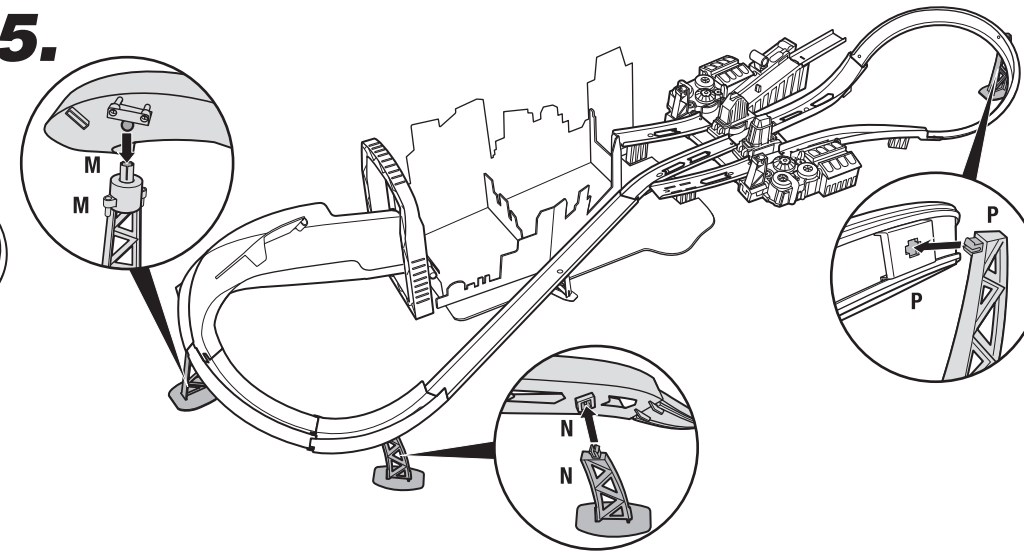

6.

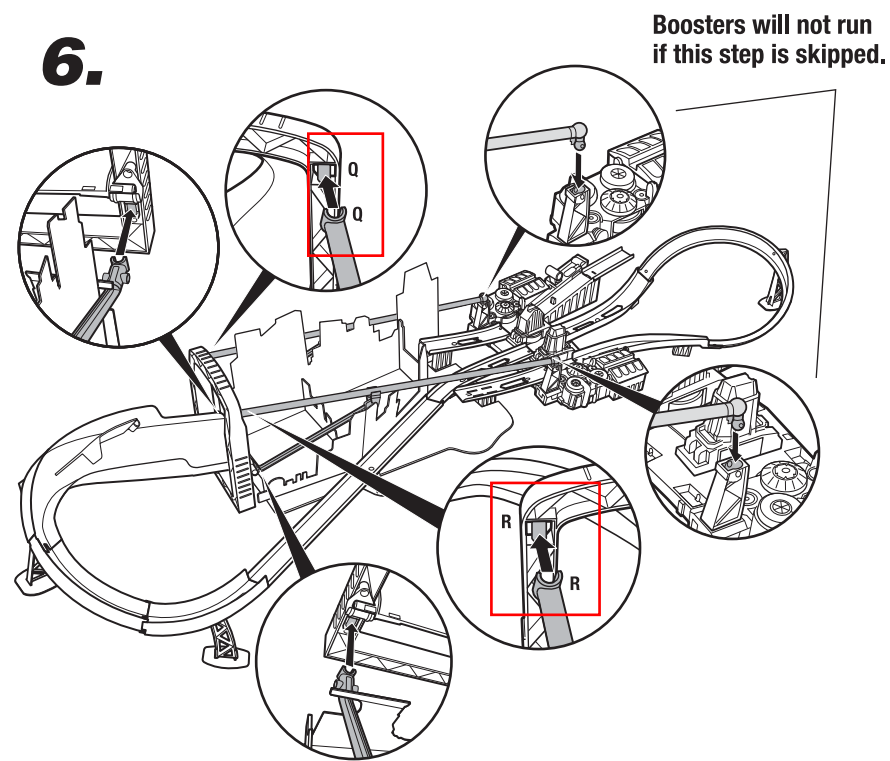

Boosters will not run if this step is skipped.

TO PLAY

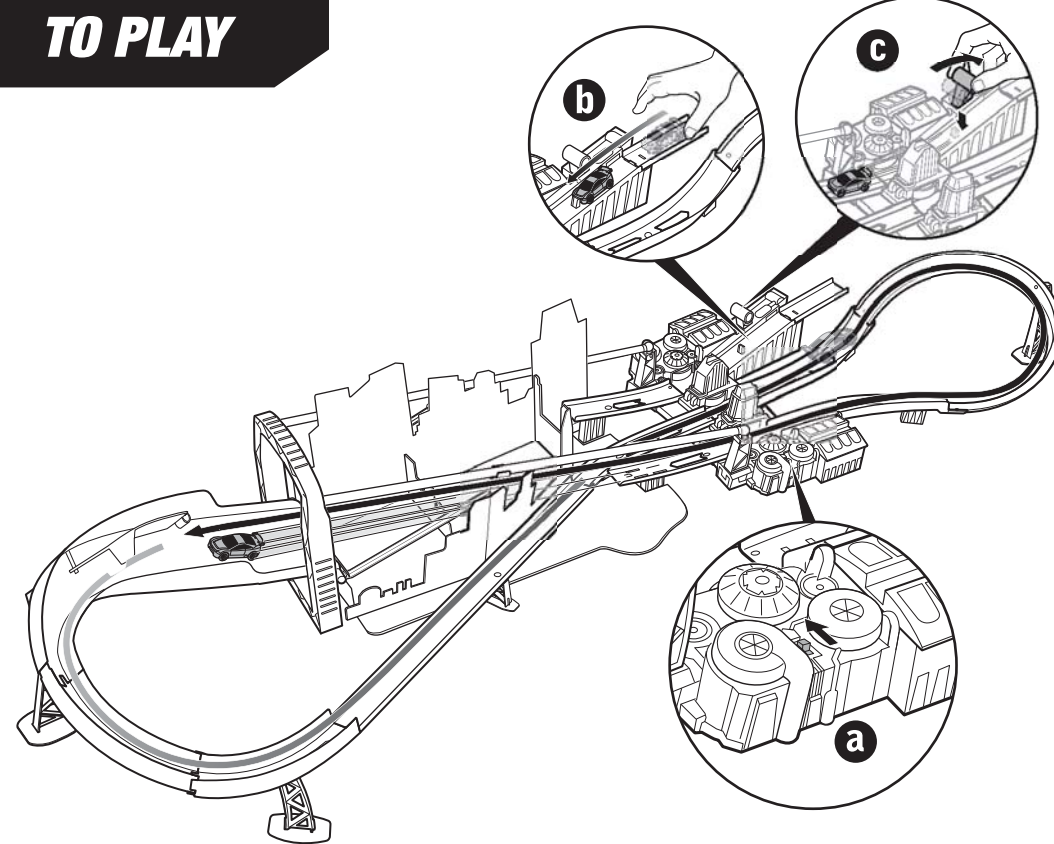

For optimal performance, play on carpet or with supports taped to floor.



5+



SUPER JUMP RACEWAY

INSTRUCTIONS

Please keep these instructions for future reference as they contain important information.

CONTENTS

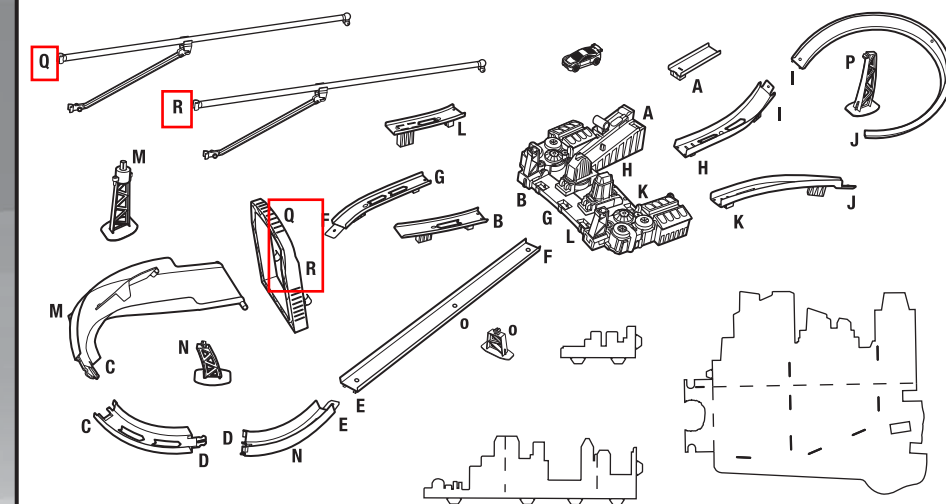

Requires 4-D(LR20) alkaline batteries (not included).

© 2008 Mattel, Inc. All Rights Reserved.

Consumer Relations - Mattel, Inc., 636 Girard Avenue, East Aurora, NY 14052, U.S.A. - 1-800-524-8697, service.mattel.com™. • Mattel Canada Inc., Mississauga, Ontario L5R 3W2. You may call us free at 1-800-524-8697. • Mattel U.K. Ltd., Vanwall Business Park, Maidenhead SL6 4UB, Helpline 01628500303 • Mattel Australia Pty., Ltd., Richmond, Victoria, 3121. Consumer Advisory Service - 1300 135 312. • Mattel East Asia Ltd., Room 1106, South Tower, World Finance Centre, Harbour City, Tsimshatsui, HK, China. • Diimport & Diedarkan Oleh: Mattel SEA Ptd Ltd.(993532-P) Lot 13.5, 13th Floor, Menara Lien Hoe, Persiaran Tropicana Golf Country Resort, 47410 PJ. Tel:03-78803817, Fax:03-78803867.



BATTERY INSTALLATION/REPLACEMENT

- Open battery cover.
- Insert 4 - D(LR20) alkaline batteries in the orientation shown.
- Close battery cover. For optimal performance use only alkaline batteries.
- Replace the batteries when the booster runs slowly or no longer propels the cars through the set.

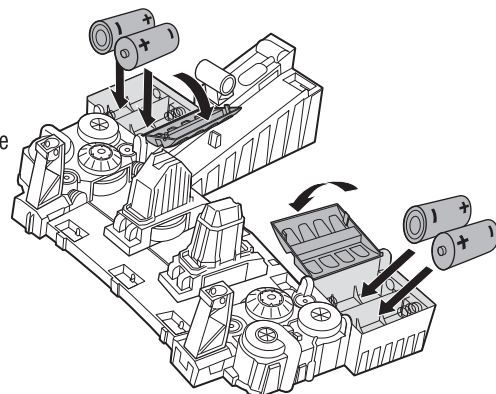

BATTERY SAFETY INFORMATION

- In exceptional circumstances batteries may leak fluids that can cause a chemical burn injury or ruin your product. To avoid battery leakage:
- Non-rechargeable batteries are not to be recharged.
 - Rechargeable batteries are to be removed from the product before being charged (if designed to be removable).
 - Rechargeable batteries are only to be charged under adult supervision (if designed to be removable).
 - Do not mix alkaline, standard (carbon-zinc), or rechargeable (nickel-cadmium) batteries.
 - Do not mix old and new batteries.

- Only batteries of the same or equivalent type as recommended are to be used.
- Batteries are to be inserted with the correct polarity.
- Exhausted batteries are to be removed from the product.
- The supply terminals are not to be short-circuited.
- Dispose of battery(ies) safely.
- Do not dispose of this product in a fire. The batteries inside may explode or leak.

Protect the environment by not disposing of this product with household waste [2002/96/EC]. Check your local authority for recycling advice and facilities.

This device complies with Part 15 of the FCC Rules.

Operation is subject to the following two conditions:
(1) This device may not cause harmful interference, and (2) this device must accept any interference received, including interference that may cause undesired operation.

This equipment has been tested and found to comply with the limits for a Class B digital device, pursuant to part 15 of the FCC rules. These limits are designed to provide reasonable protection against harmful interference in a residential installation. This equipment generates, uses and can radiate radio frequency energy and, if not installed and used in accordance with the instructions, may cause harmful interference to radio communications. However, there is no guarantee that interference will not occur in a particular installation. If this equipment does cause harmful interference to radio or television reception, which can be determined by turning the equipment off and on, the user is encouraged to try to correct the interference by one or more of the following measures:

- Reorient or relocate the receiving antenna.
- Increase the separation between the equipment and receiver.
- Connect the equipment into an outlet on a circuit different from that to which the receiver is connected.
- Consult the dealer or an experienced radio/TV technician for help.

NOTE: Changes or modifications not expressly approved by the manufacturer responsible for compliance could void the user's authority to operate the equipment.

OPERATING TIPS

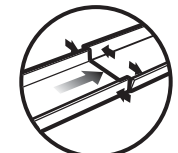

Adjust track side walls at each connection point as shown.

ASSEMBLY

1.

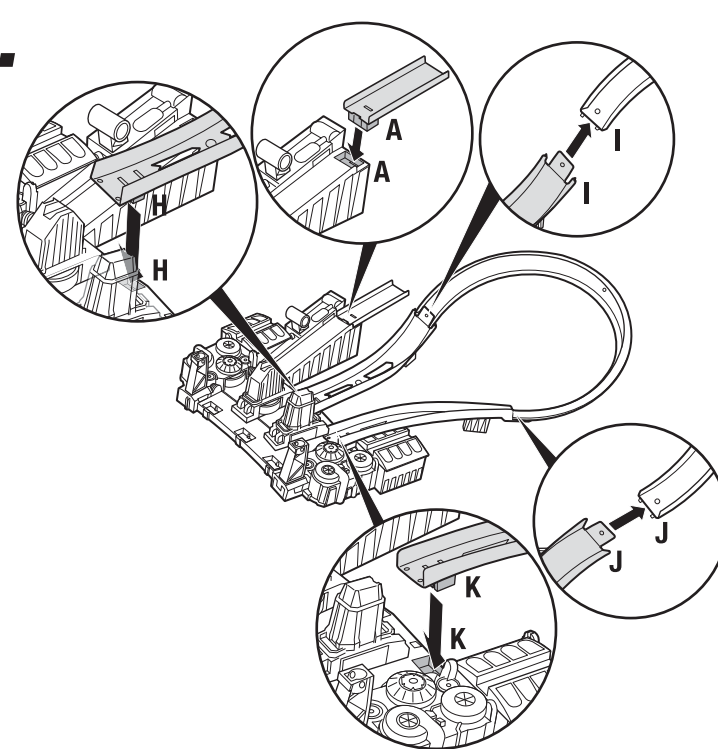

2.

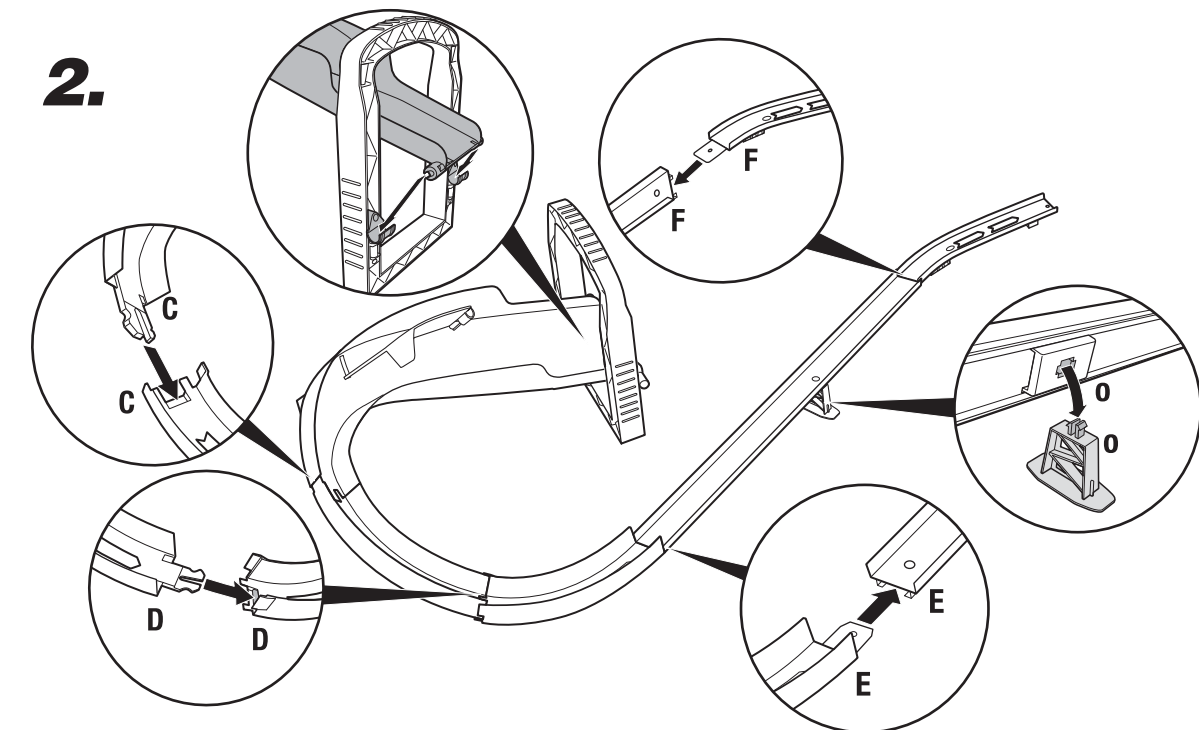

3.

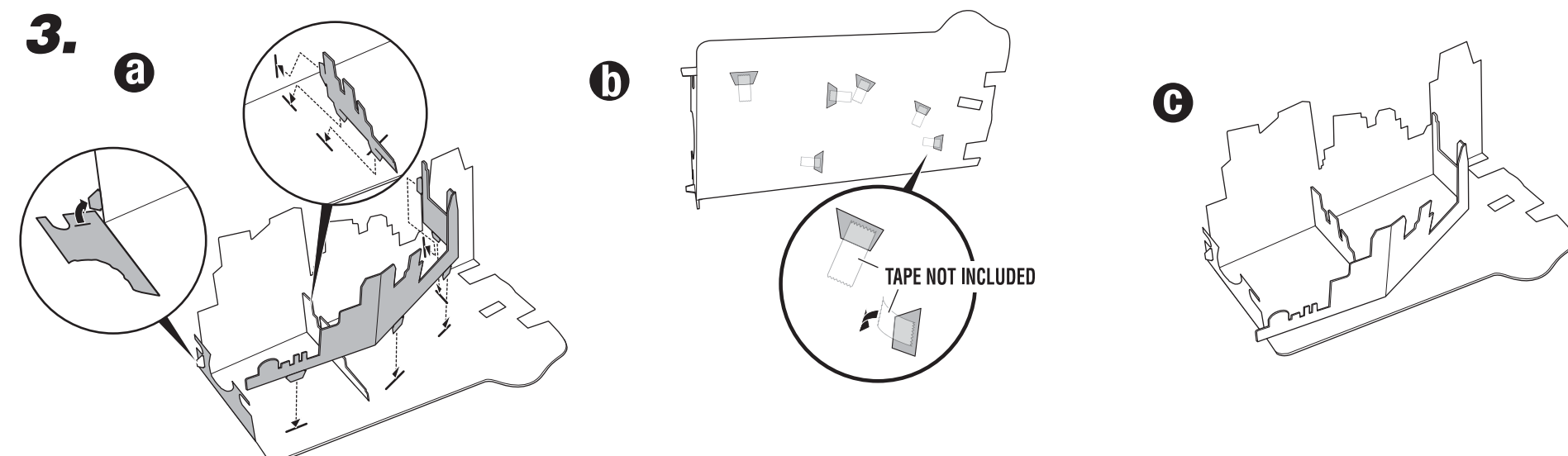

TAPE NOT INCLUDED