

Fisher-Price®



**Please keep this instruction sheet for future reference,
as it contains important information.**

Requires three "AA" batteries for operation (included).

Adult assembly is required.

Tool required for battery replacement: Phillips screwdriver (not included).

imaginext®

Battery Replacement

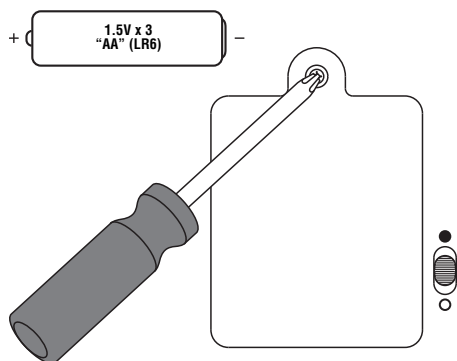

For best performance, we recommend replacing the batteries that came with this toy with three, new "AA" (LR6) alkaline batteries.

- Locate the battery compartment door on the bottom of the toy.
- Loosen the screw in the battery compartment door with a Phillips screwdriver. Remove the battery compartment door.
- Remove the exhausted batteries and throw them away.
- Insert three "AA" (LR6) **alkaline** batteries.

Hint: We recommend using alkaline batteries for longer battery life.

- Replace the battery compartment door and tighten the screw with a Phillips screwdriver.
- If this toy begins to operate erratically, you may need to reset the electronics. Slide the power switch off and then back on.
- When sounds or lights from this toy become faint or stop, it's time for an adult to change the batteries.



Protect the environment by not disposing of this product with household waste (2002/96/EC). Check your local authority for recycling advice and facilities (Europe only).

Battery Safety Information

In exceptional circumstances, batteries may leak fluids that can cause a chemical burn injury or ruin your product. To avoid battery leakage:

- Do not mix old and new batteries or batteries of different types: alkaline, standard (carbon-zinc) or rechargeable (nickel-cadmium).
- Insert batteries as indicated inside the battery compartment.
- Remove batteries during long periods of non-use. Always remove exhausted batteries from the product. Dispose of batteries safely. Do not dispose of this product in a fire. The batteries inside may explode or leak.
- Never short-circuit the battery terminals.
- Use only batteries of the same or equivalent type, as recommended.
- Do not charge non-rechargeable batteries.
- Remove rechargeable batteries from the product before charging.
- If removable, rechargeable batteries are used, they are only to be charged under adult supervision.

Setup

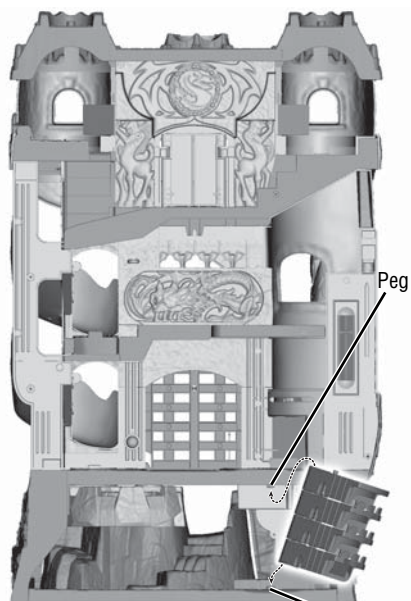

Button

- If the stairway detaches from the castle, simply re-attach it!
- At an angle, first fit the circular indent on the stairs onto the button on the castle. Then, push to “snap” the hexagonal indent on the stairs onto the peg on the castle.



- At an angle, insert the bottom of the support into the notch in the castle base. Then, push to “snap” the top of the support in place.

Consumer Information



CONSUMER ASSISTANCE
1-800-432-5437 (US & Canada)
1300 135 312 (Australia)

service.fisher-price.com

Fisher-Price, Inc., 636 Girard Avenue, East Aurora, NY 14052.
Hearing-impaired consumers: 1-800-382-7470.

Outside the United States:

Canada: Mattel Canada Inc., 6155 Freemont Blvd.,
Mississauga, Ontario L5R 3W2; www.service.mattel.com.

Great Britain: Mattel UK Ltd, Vanwall Business Park, Maidenhead SL6 4UB, Helpline: 01628 500303, www.service.mattel.com/uk

Australia: Mattel Australia Pty. Ltd., 658 Church Street,
Locked Bag #870, Richmond, Victoria 3121 Australia.

New Zealand: 16-18 William Pickering Drive,
Albany 1331, Auckland.

ICES-003

This Class B digital apparatus complies with Canadian ICES-003. Operation is subject to the following two conditions: (1) this device may not cause harmful interference and (2) this device must accept any interference received, including interference that may cause undesired operation.

NMB-003

Cet appareil numérique de la classe B est conforme à la norme NMB-003 du Canada. L'utilisation de ce dispositif est autorisée seulement aux conditions suivantes: (1) il ne doit pas produire de brouillage et (2) l'utilisateur du dispositif doit être prêt à accepter tout brouillage radioélectrique reçu, même si ce brouillage est susceptible de compromettre le fonctionnement du dispositif.

Care

- Wipe the toy with a clean cloth dampened with a mild soap and water solution. Do not immerse the toy.
- This toy has no consumer serviceable parts. Do not take this toy apart.

FCC Statement (United States Only)

This equipment has been tested and found to comply with the limits for a Class B digital device, pursuant to Part 15 of the FCC Rules. These limits are designed to provide reasonable protection against harmful interference in a residential installation. This equipment generates, uses and can radiate radio frequency energy and, if not installed and used in accordance with the instructions, may cause harmful interference to radio communications. However, there is no guarantee that interference will not occur in a particular installation. If this equipment does cause harmful interference to radio or television reception, which can be determined by turning the equipment off and on, the user is encouraged to try to correct the interference by one or more of the following measures:

- Reorient or relocate the receiving antenna.
- Increase the separation between the equipment and receiver.
- Consult the dealer or an experienced radio/TV technician for help.

Note: Changes or modifications not expressly approved by the manufacturer responsible for compliance could void the user's authority to operate the equipment. This device complies with Part 15 of the FCC Rules. Operation is subject to the following two conditions: (1) this device may not cause harmful interference and (2) this device must accept any interference received, including interference that may cause undesired operation.

Unlock the Adventure!

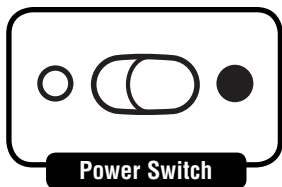

- Slide the power switch on the bottom of the toy ON ● or OFF ○.



- Place a figure on the disk and turn for lights and sounds.

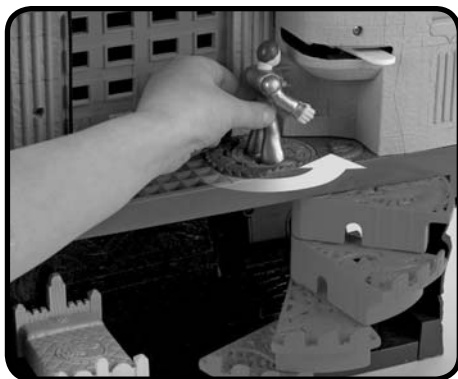

- Place a figure on the disk and turn to reveal stairs!

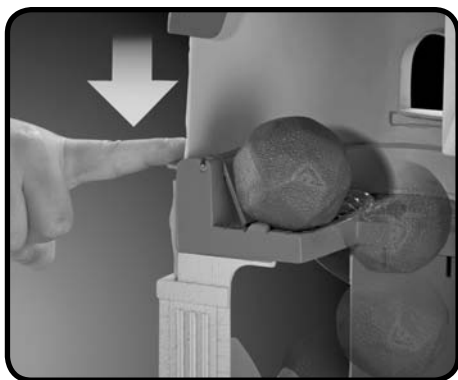

- Press to release boulder down the stairs!



- Place a figure on the disk and turn to open the gate and hear dragon sounds!



- Slide the switch to make the dragon lunge forward!



- Slide the lever to move the dragon's head side to side.



- Push to fire the cannon!
- Do not aim at eyes or face. Only use projectiles supplied with this toy. Do not fire at point blank range.