

All WWE programming, talent names, images, likenesses, slogans, wrestling moves, trademarks, logos and copyrights are the exclusive property of World Wrestling Entertainment, Inc. and its subsidiaries. All other trademarks, logos and copyrights are the property of their respective owners. © 2010 World Wrestling Entertainment, Inc. All Rights Reserved.

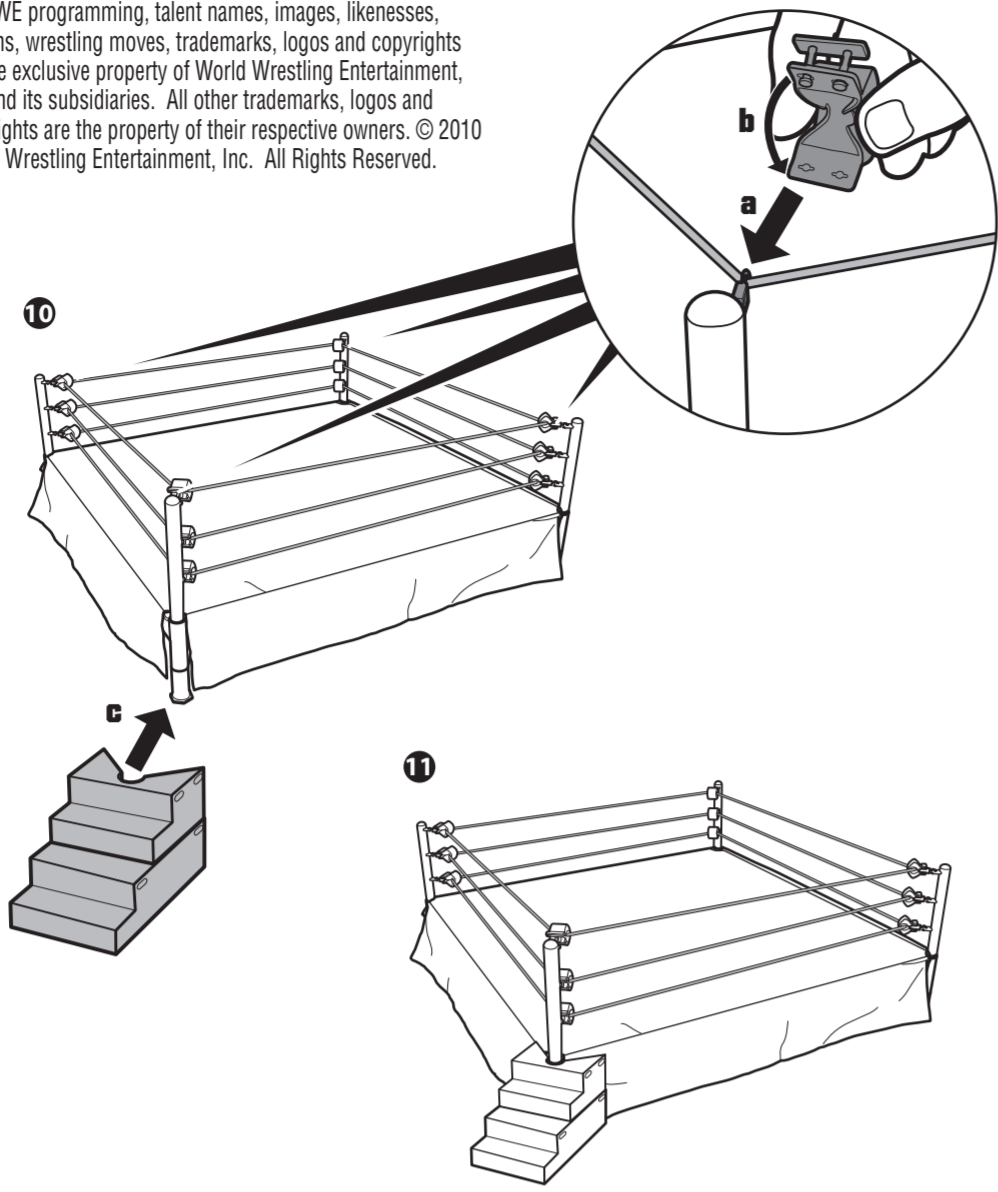

© Mattel, Inc. All Rights Reserved.
 Mattel, Inc. 636 Girard Avenue, East Aurora, NY 14052, U.S.A. Consumer Relations 1-800-524-8697. Mattel Canada Inc., Mississauga, Ontario L5R 3W2. You may call us free at 1-800-524-8697. Mattel U.K. Ltd., Vanwall Business Park, Maidenhead SL6 4UB. Helpline 01628 500303. Mattel Australia Pty., Ltd., Richmond, Victoria, 3121. Consumer Advisory Service - 1300 135 312. Mattel East Asia Ltd., Room 1106, South Tower, World Finance Centre, Harbour City, Tsimshatsui, HK, China. Diimport & Diedarkan Oleh: Mattel SEA Ptd Ltd.(993532-P) Lot 13.5, 13th Floor, Menara Lien Hoe, Persiaran Tropicana Golf Country Resort, 47410 PJ. Tel:03-78803817, Fax:03-78803867.

P9604-0920



service.mattel.com



ELITE SCALE RING INSTRUCTIONS

6+

Please keep these instructions for future reference as they contain important information.

CONTENTS

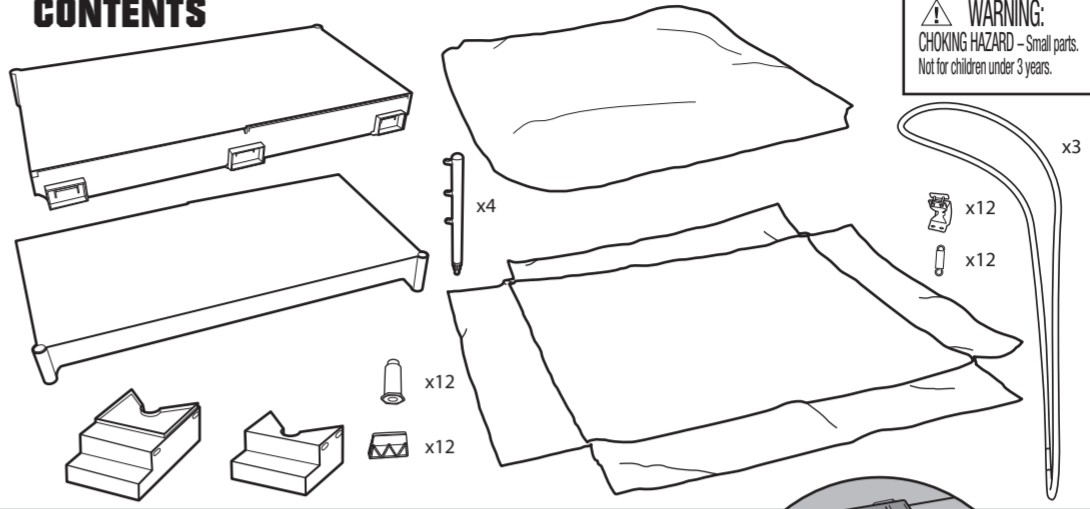

WARNING:
 CHOKING HAZARD - Small parts.
 Not for children under 3 years.

ASSEMBLY

