

Fisher-Price®

T4262



Please keep this instruction sheet for future reference,
as it contains important information.

Maximum weight: 44 lbs. (20 kg).

For ages between 9 months and 3 years.

Requires three "AA" batteries (included).

Adult assembly is required.

Tool required for assembly: Phillips screwdriver (not included).

www.fisher-price.com

Consumer Information

WARNING

To avoid serious injury:
Not for children with
a body weight of more
than 44 lb (20 kg).

CAUTION

This package contains
small parts in its
unassembled state. Adult
assembly is required.

ICES-003

This Class B digital apparatus complies with Canadian ICES-003. Operation is subject to the following two conditions: (1) this device may not cause harmful interference and (2) this device must accept any interference received, including interference that may cause undesired operation.

NMB-003

Cet appareil numérique de la classe B est conforme à la norme NMB-003 du Canada. L'utilisation de ce dispositif est autorisée seulement aux conditions suivantes: (1) il ne doit pas produire de brouillage et (2) l'utilisateur du dispositif doit être prêt à accepter tout brouillage radioélectrique reçu, même si ce brouillage est susceptible de compromettre le fonctionnement du dispositif.

Assembled Parts



Base



2 Rear Wheels



2 Handles



2 Front Wheels



Head



Front Axle



#8 x 3/4" Screw - 10

Shown Actual Size

Tighten and loosen all screws
with a Phillips screwdriver.
Do not over-tighten.

Assembly

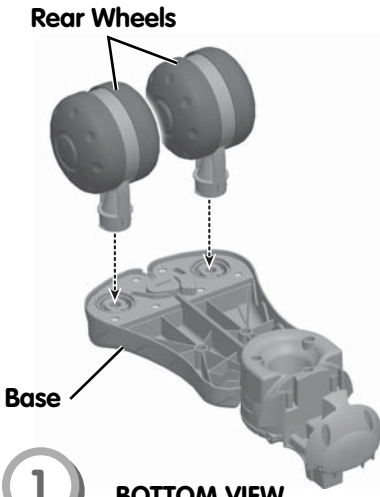

- Place the base on a flat surface so that the bottom faces you.
- Insert and “snap” the rear wheels into the sockets in the base.

Hint: This may require some force.

- Pull up on the rear wheels to be sure each is secure to the base.

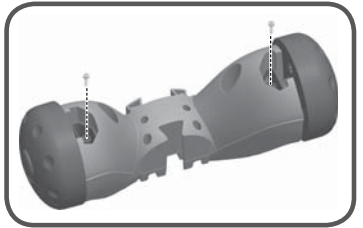
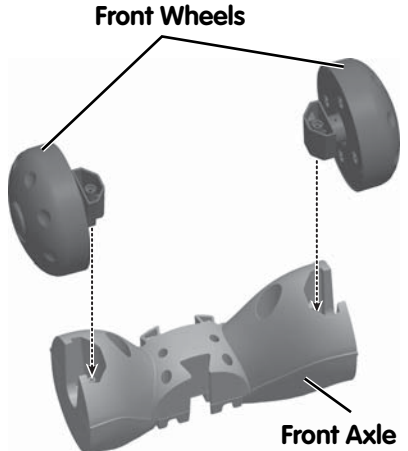

2

- Fit the front wheels to the front axle, as shown.
- Insert a screw into each front wheel and tighten.

Assembly

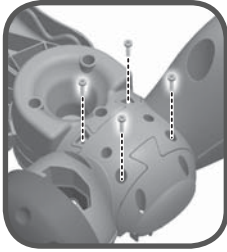
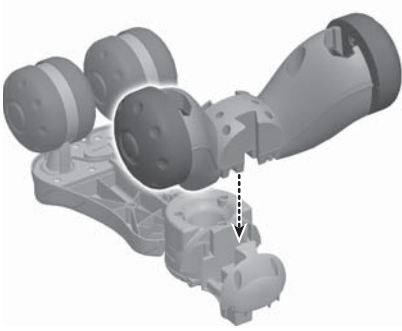

3

- Fit the front wheel assembly to the base, as shown.
- Insert four screws into the front wheel assembly and tighten.

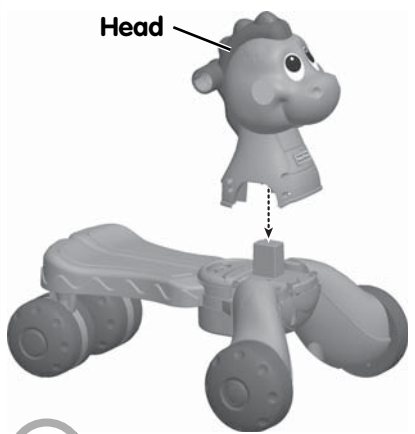

4

FRONT VIEW

- Turn the base assembly upright.
- Fit the head onto the base assembly.

Assembly

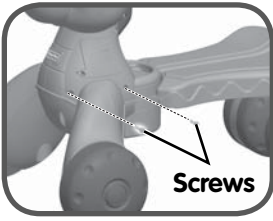

- Insert two screws into each side of the head and tighten.

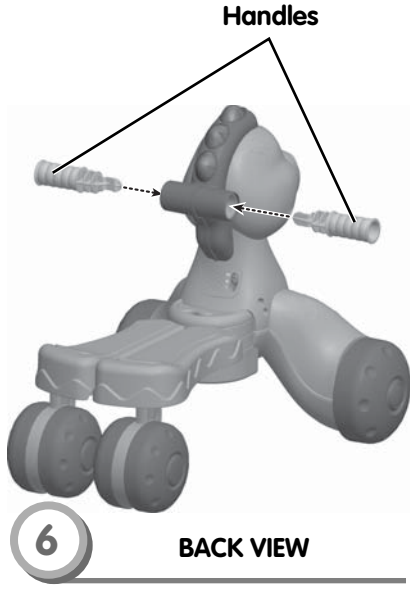

- Fit a handle into the socket on each side of the head.
- *Hint: Turn each handle so that each fits into the socket.*
- Push both handles until the "snap" together.
- Pull on each handle to be sure they are secure in the sockets.

Battery Replacement

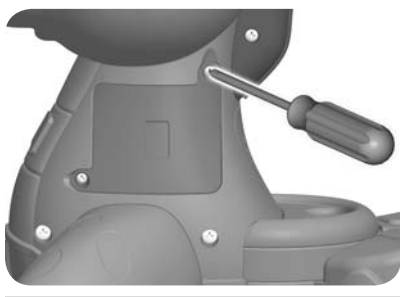

For best performance, we recommend replacing the batteries that came with three "AA" (LR6) alkaline batteries.

- Locate the battery compartment on the side of the dino.
- Loosen the screws in the battery compartment door. Remove the battery compartment door. Remove the exhausted batteries and throw them away.
- Insert three, new "AA" (LR6) **alkaline** batteries.

Hint: We recommend using **alkaline** batteries for longer battery life.

- Replace the battery compartment door and tighten the screws.
- If this toy begins to operate erratically, you may need to reset the electronics. Slide the power/volume switch off and then back on.
- When lights or sounds from this toy become faint or stop, it's time for an adult to change the batteries!



- Protect the environment by not disposing of this product with household waste (2002/96/EC). Check your local authority for recycling advice and facilities (Europe only).

Battery Safety Information

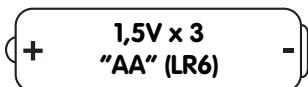

In exceptional circumstances, batteries may leak fluids that can cause a chemical burn injury or ruin your product. To avoid battery leakage:

- Do not mix old and new batteries or batteries of different types: alkaline, standard (carbon-zinc) or rechargeable (nickel-cadmium).
- Insert batteries as indicated inside the battery compartment.
- Remove batteries during long periods of non-use. Always remove exhausted batteries from the product. Dispose of batteries safely. Do not dispose of this product in a fire. The batteries inside may explode or leak.
- Never short-circuit the battery terminals.
- Use only batteries of the same or equivalent type as recommended.
- Do not charge non-rechargeable batteries.
- Remove rechargeable batteries from the product before charging.
- If removable, rechargeable batteries are used, they are only to be charged under adult supervision.

Walker

To change to Walker mode, follow these steps:

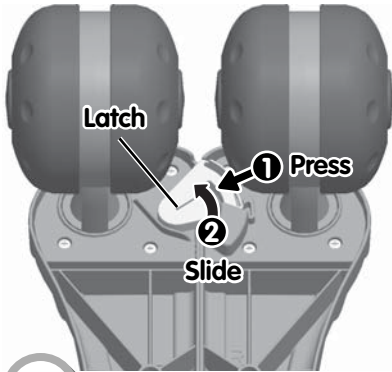

1 Bottom View

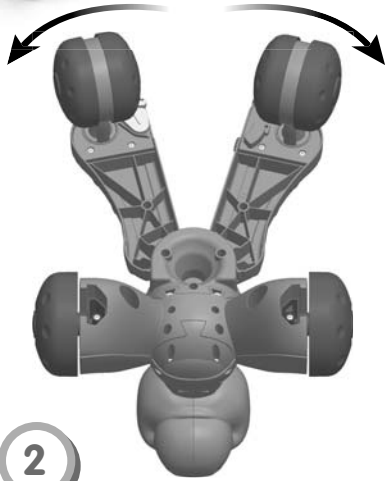

2

- Turn the toy over. Press and slide the latch to an open position, as shown.

- Spread the seat halves until they "click" in place. Turn the toy over. It is now ready to be used as a walker.

Ride-On

To change to Ride-On mode, follow these steps:

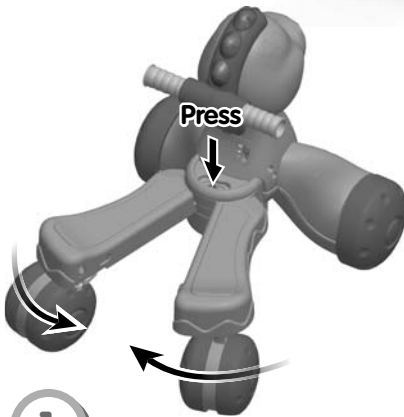

1

Top View

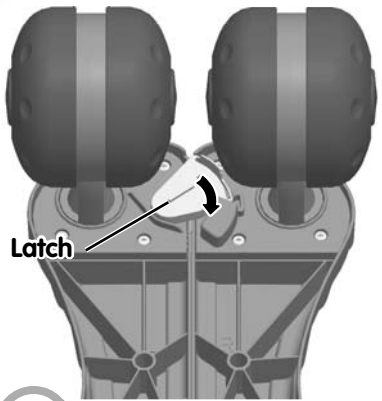

2



Bottom View

- While pressing the seat button, close the seat halves. Turn the toy over.

- Slide the latch to a closed position. It should **"click"** into place. Turn the toy over. It is now ready to be used as a ride-on.

Rewarding Lights and Music!



- Slide the power/volume switch on the back of the dino's head to ON with low volume  or ON with high volume .
- Press the lights or roll the dino along for music and fun sounds!
- When you are finished playing with this toy, slide the power/volume switch OFF .
- Wipe this toy with a clean cloth dampened with a mild soap and water solution. Do not immerse this toy.
- This toy has no consumer serviceable parts.
- Do not take this toy apart. Do not drop this toy on a hard surface.

Consumer Information



CONSUMER ASSISTANCE

1-800-432-5437 (US & Canada)
1300 135 312 (Australia)

service.fisher-price.com

Fisher-Price, Inc., 636 Girard Avenue, East Aurora, NY 14052.
Hearing-impaired consumers: 1-800-382-7470.

Outside the United States:

Canada: Mattel Canada Inc., 6155 Freemont Blvd.,
Mississauga, Ontario L5R 3W2; www.service.mattel.com.

Great Britain: Mattel UK Ltd, Vanwall Business Park,
Maidenhead SL6 4UB. Helpline: 01628 500303.
www.service.mattel.com/uk

Mattel Europa, B.V., Gondel 1, 1186 MJ Amstelveen, Nederland.

Australia: Mattel Australia Pty. Ltd., 658 Church Street,
Locked Bag #870, Richmond, Victoria 3121 Australia.

New Zealand: 16-18 William Pickering Drive,
Albany 1331, Auckland.

FCC Statement (United States Only)

This equipment has been tested and found to comply with the limits for a Class B digital device, pursuant to Part 15 of the FCC Rules. These limits are designed to provide reasonable protection against harmful interference in a residential installation. This equipment generates, uses and can radiate radio frequency energy and, if not installed and used in accordance with the instructions, may cause harmful interference to radio communications. However, there is no guarantee that interference will not occur in a particular installation. If this equipment does cause harmful interference to radio or television reception, which can be determined by turning the equipment off and on, the user is encouraged to try to correct the interference by one or more of the following measures:

- Reorient or relocate the receiving antenna.
- Increase the separation between the equipment and receiver.
- Consult the dealer or an experienced radio/TV technician for help.

Note: Changes or modifications not expressly approved by the manufacturer responsible for compliance could void the user's authority to operate the equipment.

This device complies with Part 15 of the FCC Rules. Operation is subject to the following two conditions: (1) this device may not cause harmful interference and (2) this device must accept any interference received, including interference that may cause undesired operation.